

## 5A Bipolar Linear Regulator

### DESCRIPTION

BL1084 is a series of low dropout three terminal regulators with a typical dropout voltage of 1.4V at 5A load current.

Other than fixed voltage versions (1.8V, 2.5V, 3.3V, 5.0V), BL1084 has an adjustable voltage version, with which desired voltage can be achieved by setting the values of two external resistors of the application circuitry.

BL1084 offers thermal shut down and current limit functions to assure the stability of chip and power system.

BL1084 series is available in standard packages of TO-263-2L, TO-263-3L, TO-220 and TO-252.

### FEATURES

- Fixed and adjustable versions.
- Maximum output current : 5A
- Maximum input voltage: 15V
- Line regulation: 0.2% (Typical)
- Load regulation: 0.2% (Typical)
- On-Chip Thermal Shutdown
- Operation environment Temperature: -40°C ~ 85°C

### APPLICATIONS

- Power Management for Computer Mother Board, Graphic Card
- Battery Charger
- Post Regulators for Switching Supplies
- Microprocessor Supply

### TYPICAL APPLICATION

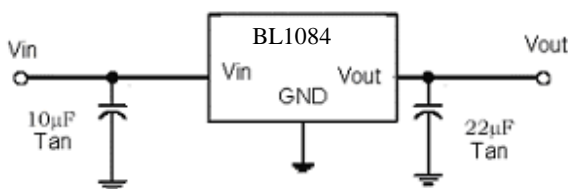

Fig 1. BL1084 fixed version Application circuit

NOTE: Input capacitor ( $C_{in}=10\mu F$ ) and Output capacitor ( $C_{out}=22\mu F$ ) are recommended in all application circuit. Tantalum capacitor is preferred.

### ELECTRICAL CHARACTERISTICS

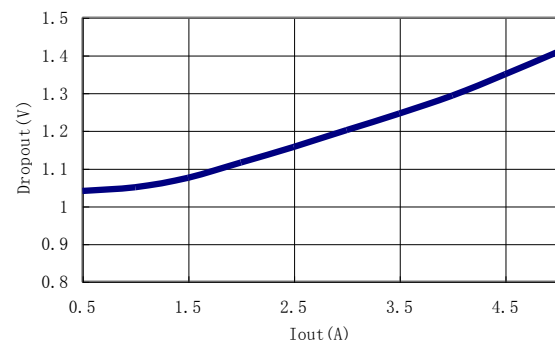

Fig 2. Dropout Voltage VS. Output Current

## ORDERING INFORMATION

BL1084 [1][2][3]

Code	Description
[1]	Output voltage: e.g. 18=1.8V 33=3.3V Default=Adjustable Version
[2]	Temperature&Rohs: C: -40~85°C ,Pb Free Rohs Std.
[3]	Package type: Y:TO-252 S:TO-263-2L S1:TO-263-3L Z:TO-220-3L

## ABSOLUTE MAXIMUM RATING

Parameter	Value	
Max Input Voltage	15V	
Operating Junction Temperature(Tj)	150°C	
Ambient Temperature(Ta)	-40°C ~85°C	
Package Thermal Resistance	TO-252	6°C / W
	TO-263	3°C / W
	TO-220	3°C / W
Storage Temperature(Ts)	-40°C -150°C	
Lead Temperature & Time	260°C,10S	

Note:

Exceed these limits to damage to the device. Exposure to absolute maximum rating conditions may affect device reliability.

## RECOMMENDED WORK CONDITIONS

Parameter	Value
Input Voltage Range	Max.15V
Operating Junction Temperature(Tj)	-20°C -125°C

## PIN CONFIGURATION

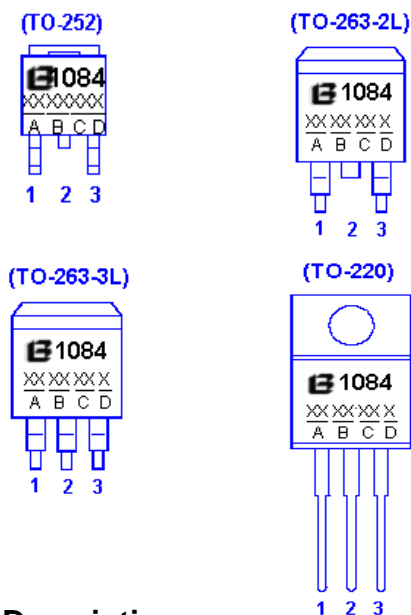

### Pin Description:

#### Fixed Version

Pin No.	Symbol	Definition
1	GND	Ground
2	Vout	Output
3	Vin	Input

#### Adjustable Version

Pin No.	Symbol	Definition
1	Adj.	Adjustable
2	Vout	Output
3	Vin	Input

### Marking information:

A: Means Manufacture weeks

B: Means Manufacture LOT No.

C:Means Output Voltage Value

D:Means Temp. Range&Rohs Std

## ELECTRICAL CHARACTERISTICS

T<sub>j</sub>=25°C

Symbol	Parameter	Conditions	Min	Typ	Max	Unit
V <sub>ref</sub>	Reference Voltage	10mA ≤ I <sub>out</sub> ≤ 5A, 1.5V ≤ V <sub>in</sub> - V <sub>out</sub> ≤ 5V	1.225	1.25	1.275	V
V <sub>out</sub>	Output Voltage	BL1084-1.80V I <sub>out</sub> =0mA, V <sub>in</sub> =4.8V, T <sub>j</sub> =25°C 10mA ≤ I <sub>out</sub> ≤ 5A, 3.4V ≤ V <sub>in</sub> ≤ 7V	1.773 1.764	1.80 1.80	1.827 1.836	V
		BL1084-2.50V I <sub>out</sub> =0mA, V <sub>in</sub> =5.5V, T <sub>j</sub> =25°C 10mA ≤ I <sub>out</sub> ≤ 5A, 4.1V ≤ V <sub>in</sub> ≤ 7V	2.462 2.45	2.50 2.50	2.537 2.55	V
		BL1084-3.3V I <sub>out</sub> =0mA, V <sub>in</sub> =6.3V, T <sub>j</sub> =25°C 10mA ≤ I <sub>out</sub> ≤ 5A, 4.9V ≤ V <sub>in</sub> ≤ 8V	3.25 3.234	3.3 3.3	3.350 3.366	V
		BL1084-5.0V I <sub>out</sub> =0mA, V <sub>in</sub> =8.0V, T <sub>j</sub> =25°C 10mA ≤ I <sub>out</sub> ≤ 5A, 6.6V ≤ V <sub>in</sub> ≤ 10V	4.925 4.90	5.0 5.0	5.075 5.10	V
ΔV <sub>out</sub>	Line Regulation (note 1)	BL1084-ADJ I <sub>out</sub> =10mA, 2.85V ≤ V <sub>in</sub> ≤ 10V		10	40	mV
		BL1084-1.8V I <sub>out</sub> =10mA, 3.4V ≤ V <sub>in</sub> ≤ 10V		10	40	mV
		BL1084-2.5V I <sub>out</sub> =10mA, 4.1V ≤ V <sub>in</sub> ≤ 10V		10	40	mV
		BL1084-3.3V I <sub>out</sub> =10mA, 4.9V ≤ V <sub>in</sub> ≤ 10V		10	40	mV
		BL1084-5.0V I <sub>out</sub> =10mA, 6.6V ≤ V <sub>in</sub> ≤ 10V		10	40	mV
ΔV <sub>out</sub>	Load Regulation (note 1,2)	BL1084-ADJ (ADJ connected to ground) V <sub>in</sub> -V <sub>out</sub> =1.6V, 10mA ≤ I <sub>out</sub> ≤ 5A		16	50	mV
		BL1084-1.8V V <sub>in</sub> -V <sub>out</sub> =1.6V, 0 ≤ I <sub>out</sub> ≤ 5A		16	50	mV
		BL1084-2.5V V <sub>in</sub> -V <sub>out</sub> =1.6V, 0 ≤ I <sub>out</sub> ≤ 5A		16	50	mV
		BL1084-3.3V V <sub>in</sub> -V <sub>out</sub> =1.6V, 0 ≤ I <sub>out</sub> ≤ 5A		16	50	mV
		BL1084-5.0V V <sub>in</sub> -V <sub>out</sub> =1.6V, 0 ≤ I <sub>out</sub> ≤ 5A		16	50	mV

$V_{in}-V_{out}$	Dropout Voltage (note 3)	$\Delta V_{out}, \Delta V_{ref}=1\%, I_{out}=5A$		1.4	1.6	V
$I_{limit}$	Current Limit	$V_{in}-V_{out}=3V, T_j=25^\circ C$		7		A
	Minimum Load Current (note 4)	BL1084-ADJ		3	10	mA
$I_q$	Quiescent Current	$V_{in}=10V$		5	10	mA
$I_{Adj}$	Adjust Pin Current (Adjustable Version)	$2.85V \leq V_{in} \leq 4.25V, 10mA \leq I_{out} \leq 5A$		45	120	$\mu A$
Ripple Rejection		$F=120Hz, C_{out}=25\mu F(\tan), I_{out}=5A, V_{in}-V_{out}=3V$	60	65		dB
$I_{change}$	Adjust Pin Current Change	$10mA \leq I_{out} \leq 5A$ $1.5V \leq V_{in}-V_{out} \leq 6V$		0.4	10	$\mu A$
	Temperature Stability	$I_{out}=10mA,$ $V_{in}-V_{out}=1.5V$			0.5	%
$\theta_{JC}$	Thermal Resistance junction to case	TO-252 TO-263 TO-220		12.5 3 3		$^\circ C / W$
OTP	Over Temperature Protection			150		$^\circ C$

Note1: Line Regulation and Load Regulation in Table1 are tested under constant junction temperature.

Note2: When load current varies between 0~5A and  $V_{in}-V_{out}$  ranges from 1.5V~6V at constant junction temperature, the parameter is satisfied the criterion in table. If temperature varies between  $-40^\circ C \leq T_A \leq 85^\circ C$ , it needs output current to be larger than 10mA to satisfy the criterion.

Note3: Dropout Voltage is the voltage difference between the input and output pin when the input voltage is minimum to maintain the lowest spec output voltage.

Dropout Voltage is the voltage difference between the input and output pin under  $I_{out}=5A$  and the following test condition:

- 1) Find out output voltage value (denoted as  $V_{out1}$ ) when  $V_{in1}=V_{out1}+1.5V$
- 2) Decrease input voltage until output voltage is equal to 98.5% of  $V_{out1}$ , and denote the  $V_{in}$  and  $V_{out}$  as  $V_{in2}$  and  $V_{out2}$ .
- 3)  $V_{dropout}=V_{in2}-V_{out2}$ .

Note4: Minimum Load Current is defined as the minimum output current necessary to maintain regulation. Specified output accuracy can be met when the output current exceeds the minimum load current (10mA) and the dropout voltage ( $V_{in}-V_{out}$ ) lies between 1.5V and 6V.

## BLOCK DIAGRAM

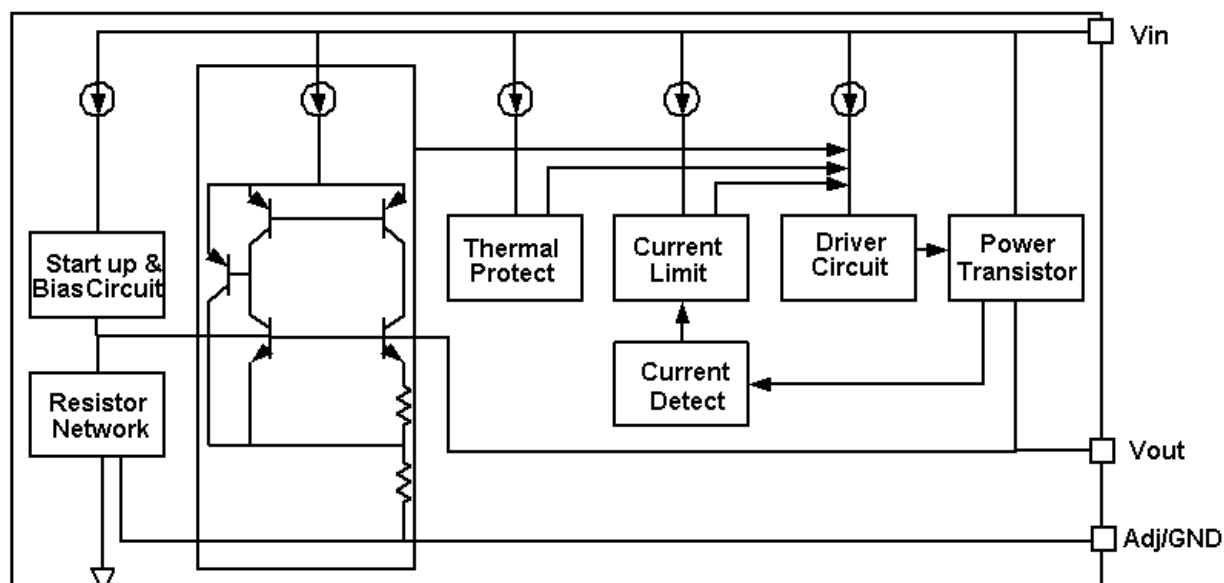

Fig 3. Block Diagram

## DETAILED DESCRIPTION

BL1084 is a series of low dropout voltage three terminal regulators. Its circuit has a trimmed bandgap reference to ensure output voltage accuracy independent of temperature variance. On-chip thermal shutdown provides protection against overload and conditions as elevated ambient temperature.

Its application circuitry requires minimum number of external components. Both fixed voltage and adjustable voltage versions need input and output capacitors to assure output voltage stability. Any desired output voltage from 1.25V to 10V can be achieved with adjustable version by assigning proper values to two external resistors in its application circuitry (as shown in Fig.4, as R1, R2 are the two external resistors.).

## TYPICAL APPLICATION

BL1084 has an adjustable version and fixed versions, Fig.4 shows their typical application circuitry. A 10uF tan capacitor connected between input and GND as bypass capacitor and a 22uF tan capacitor between output and GND are recommended for all application.

Using a bypass capacitor ( $C_{Adj}$ ) between the adjust terminal and ground can improve ripple rejection. The bypass capacitor prevents ripple from being amplified in case the output voltage is increased. The impedance of  $C_{Adj}$  should be less than the resistance of  $R_1$  to prevent ripple from being amplified at any frequency. As  $R_1$  is normally in the range of 120Ω~200Ω, the value of  $C_{Adj}$  should satisfy the following condition:

$$1/(2\pi * \text{Frequency}_{\text{Ripple}} * C_{\text{adj}}) < R_1$$

A 10μF tan capacitor is recommended.

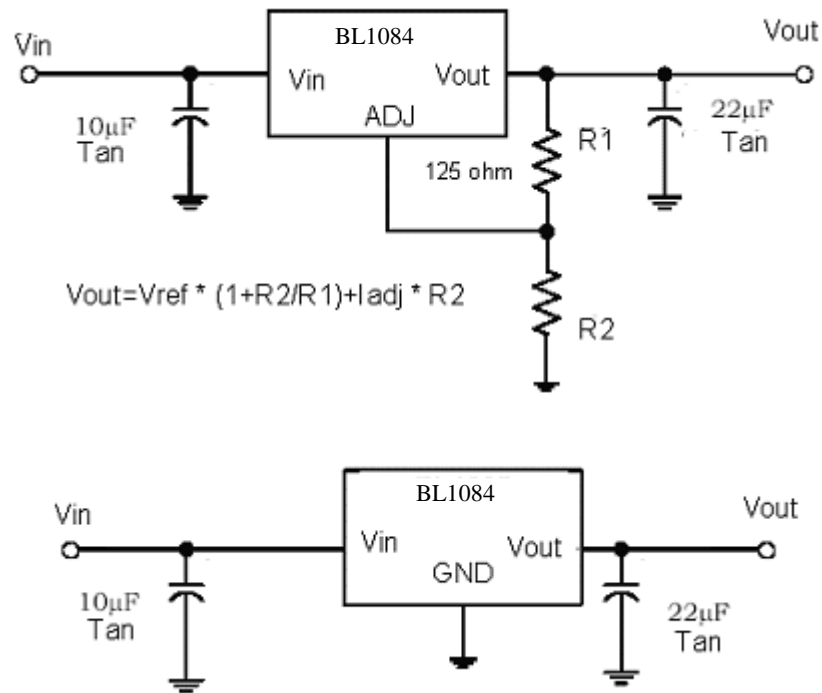

Fig 4. Typical Application of BL1084

## EXPLANATION

The output voltage of adjustable version satisfies this followed equation:

$$V_{out} = V_{Ref} \times (1 + R_2/R_1) + I_{Adj} \times R_2.$$

The second term  $I_{Adj} \times R_2$  can be ignored since the adjustable pin current  $I_{Adj}$  ( $\sim 50 \mu A$ ) is much less than the current through  $R_1$  ( $\sim 4mA$ ).

The value of  $R_1$  is preferred in the range of  $120\Omega \sim 200\Omega$  and the total output current of the adjustable version of BL1084 needs to exceed 10mA to assure normal chip operation.

## TYPICAL PERFORMANCE CHARACTERISTICS

### Dropout Voltage VS. Output Current

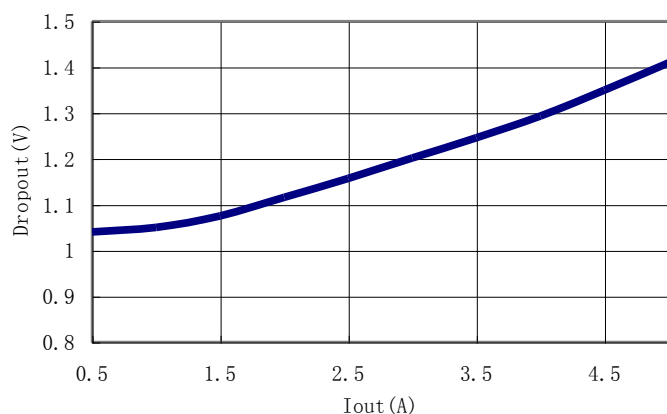

### Output Voltage VS. Temperature

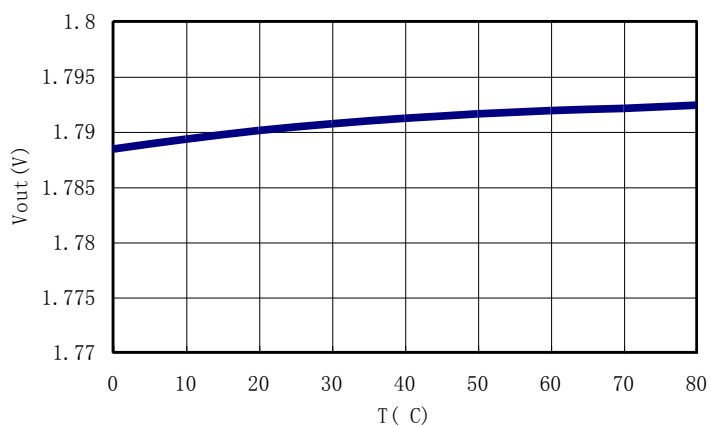

### Output Voltage VS. Output Current

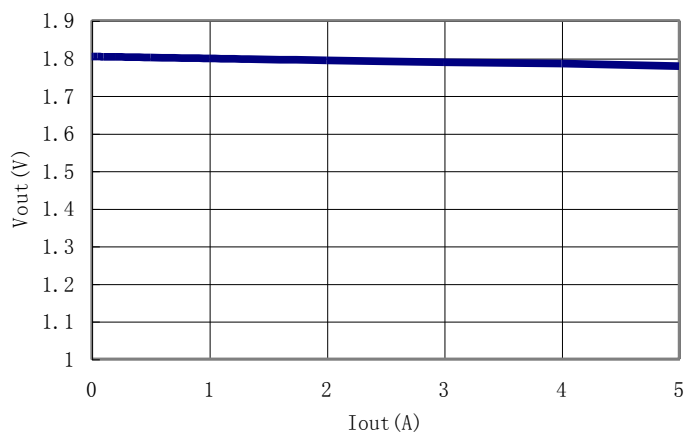

### Load Transient Response

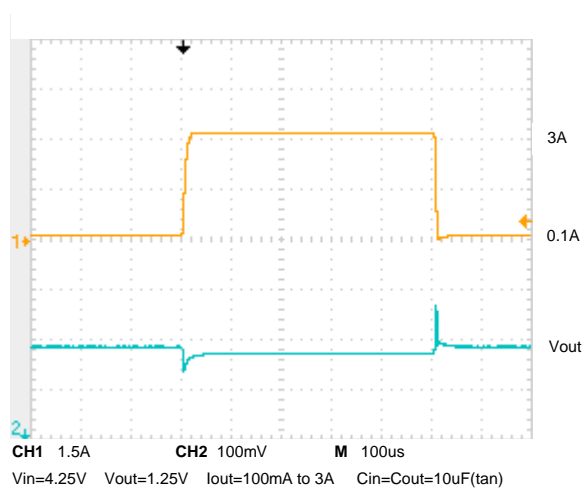

### Line Transient Response

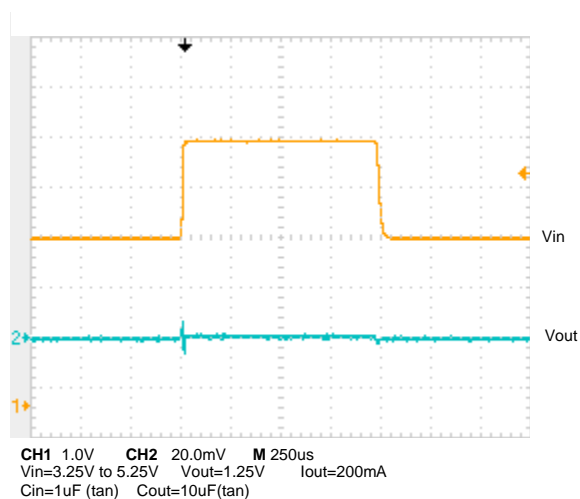

## PACKAGE LINE

Package	TO-252	Devices per reel	2500	Unit	mm
---------	--------	------------------	------	------	----

Package specification:

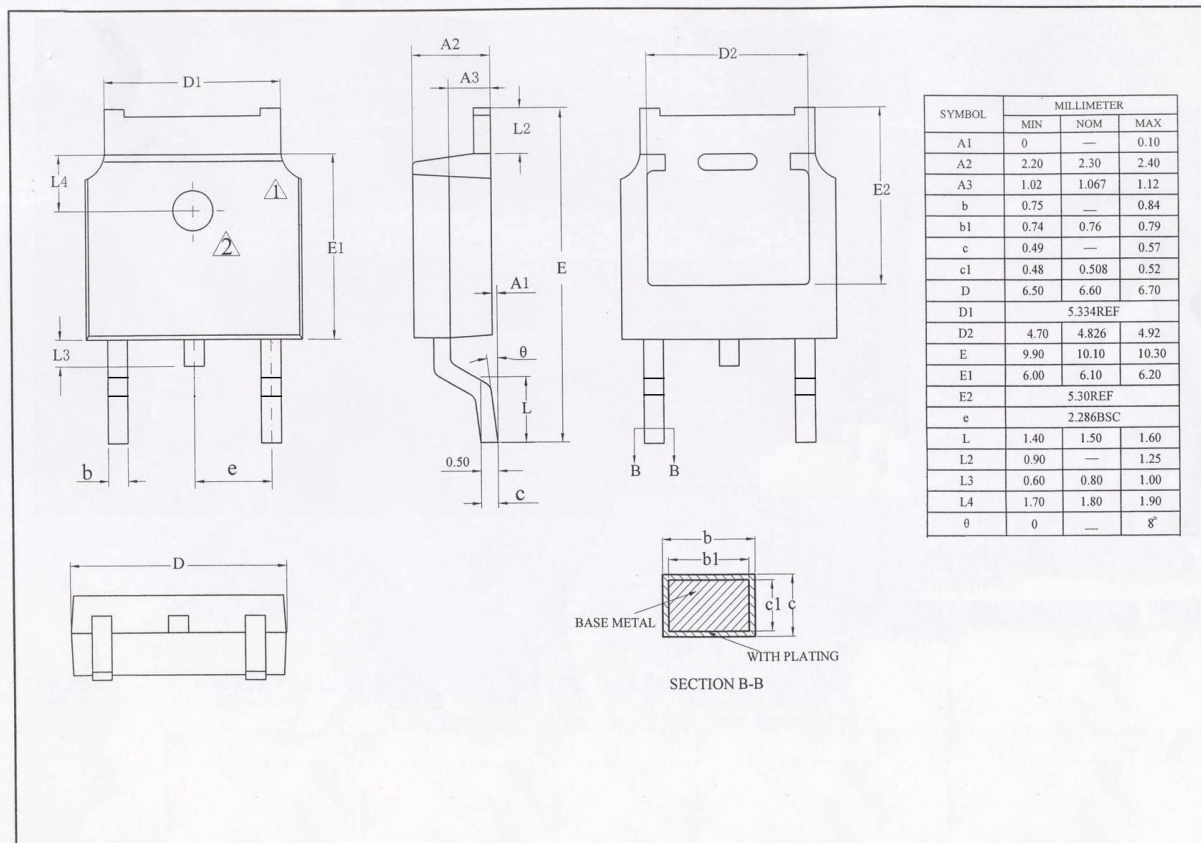

Taping dimension:

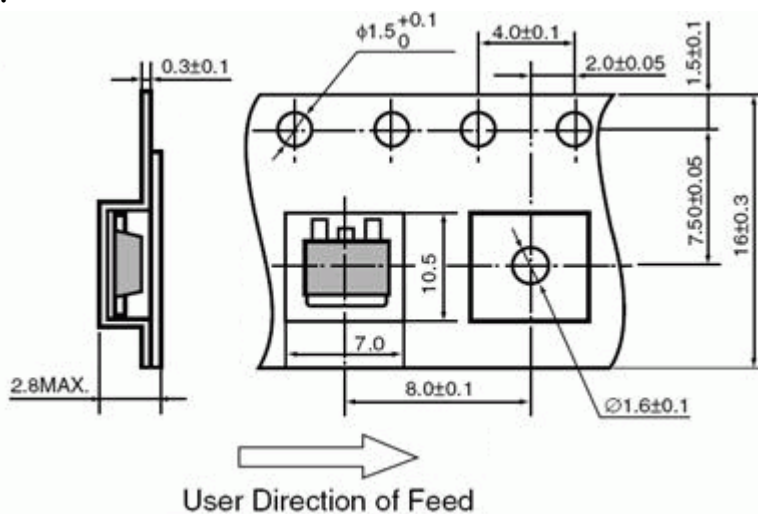



Taping reel dimension:

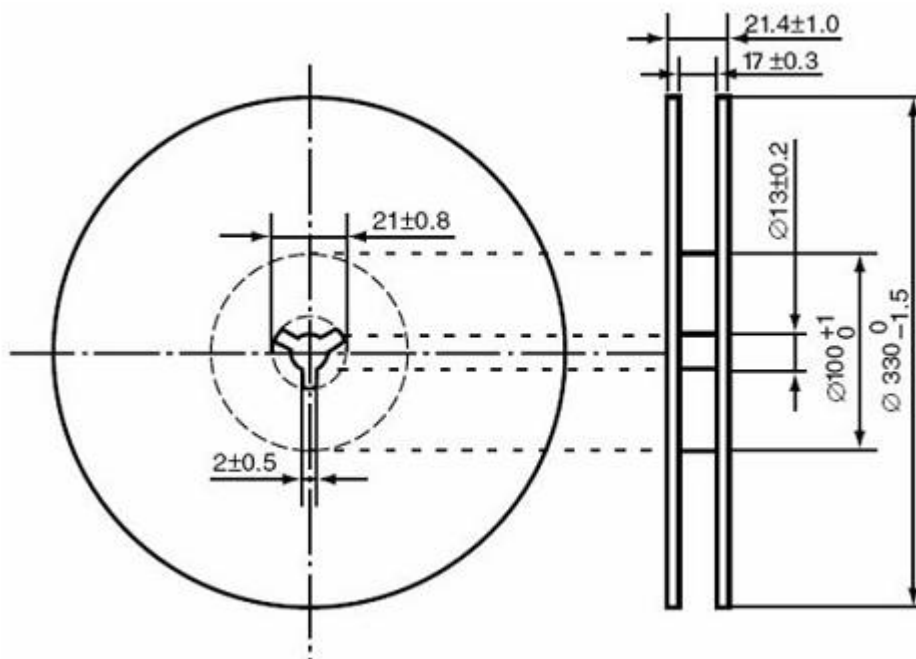

Package	TO-263-2L	Devices per reel	800	Unit	mm
---------	-----------	------------------	-----	------	----

### Package specification:

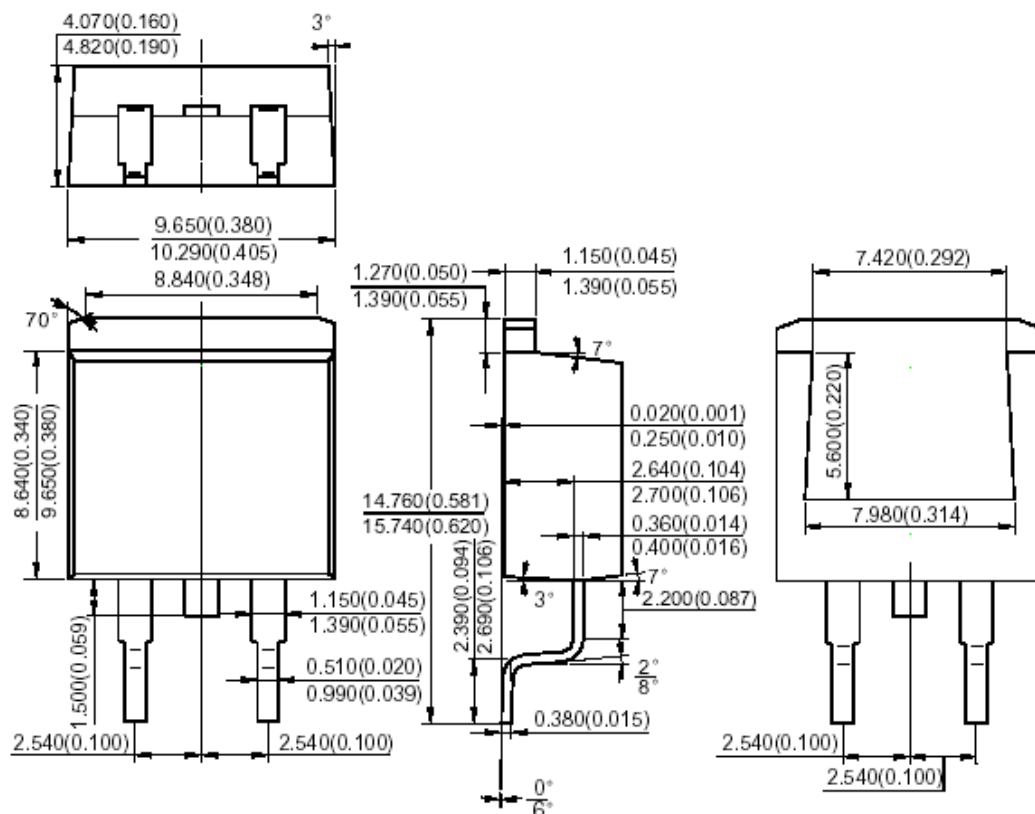

### Taping dimension:

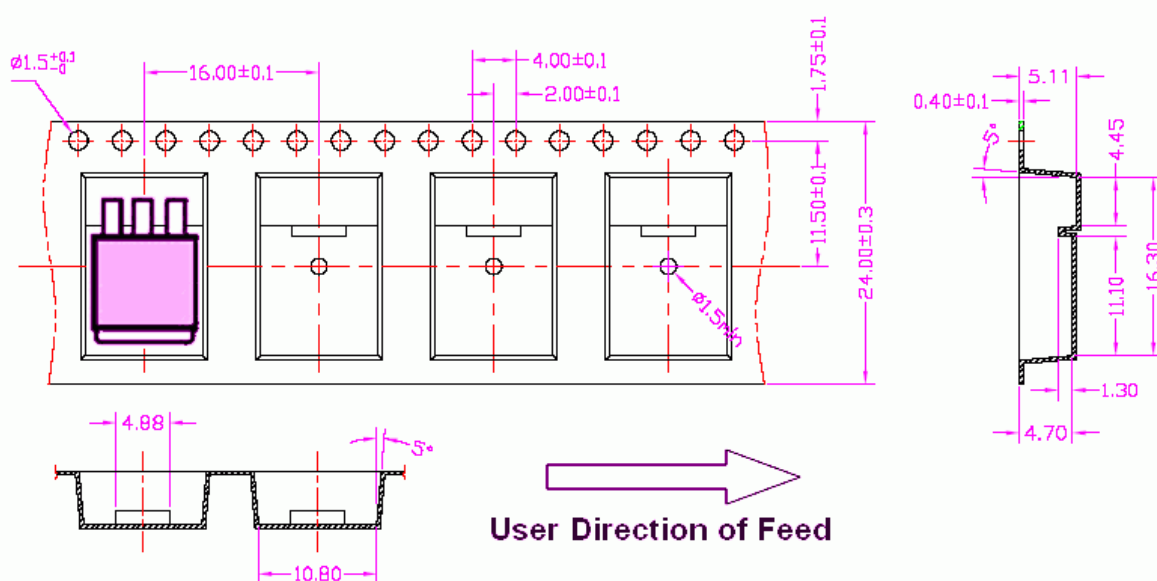

Taping reel dimension:

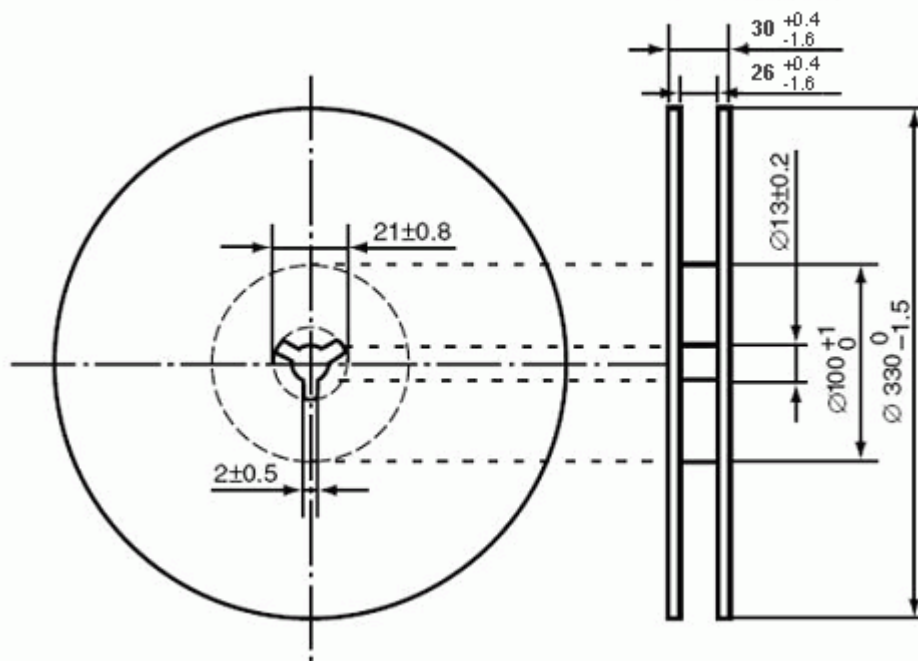

Package	TO-263-3L	Devices per reel	800	Unit	mm
---------	-----------	------------------	-----	------	----

**Package specification:**

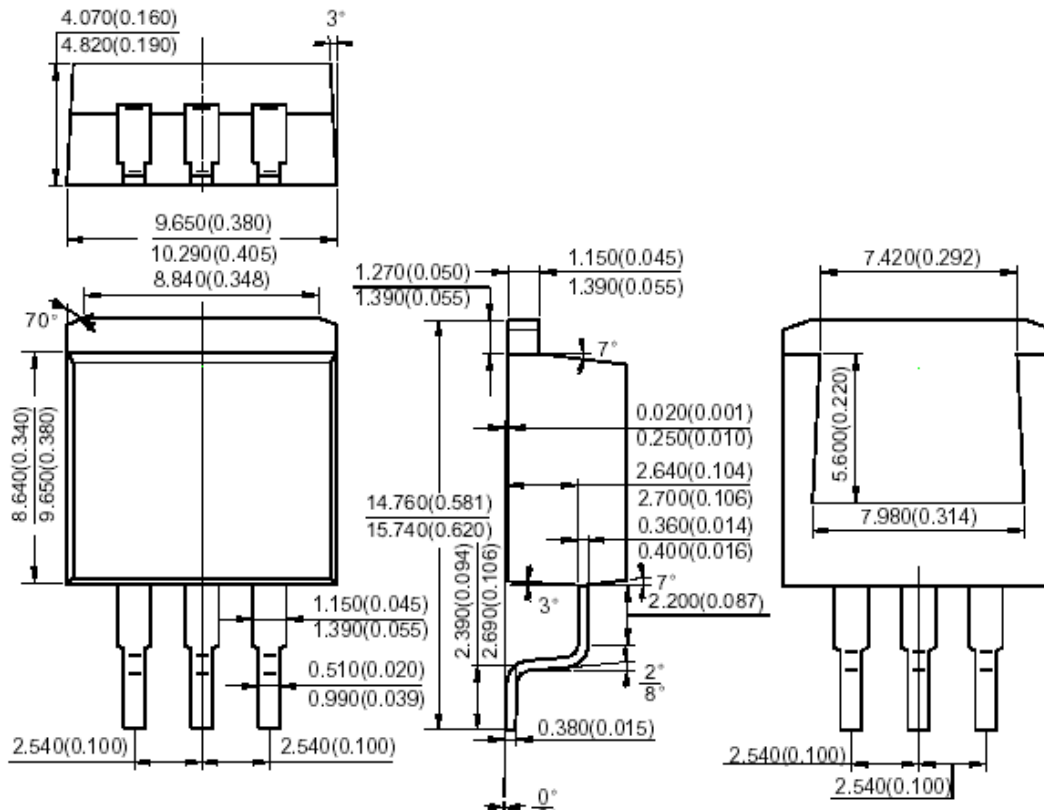

**Taping dimension:**

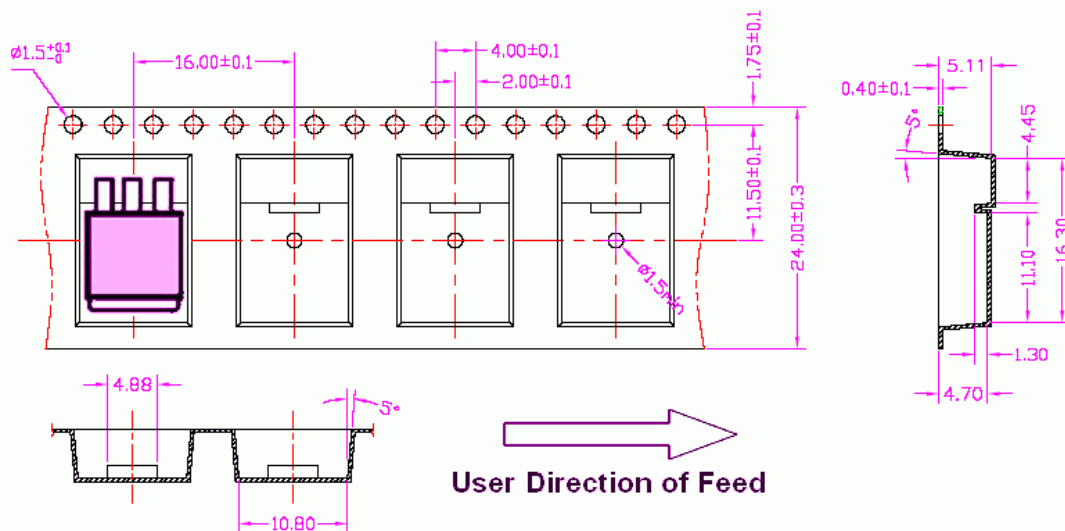

Taping reel dimension:

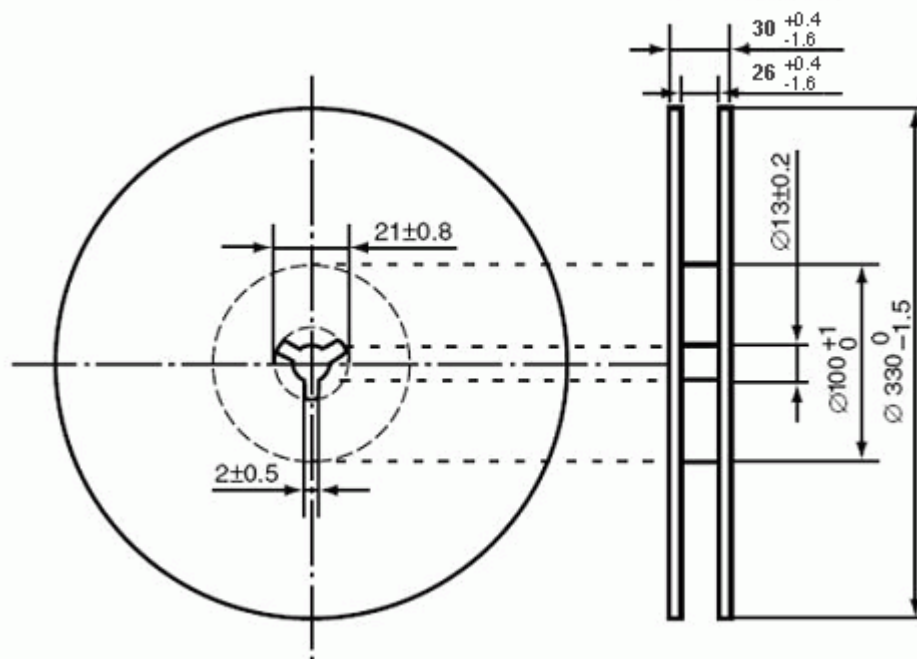

## X-ON Electronics

Largest Supplier of Electrical and Electronic Components

*Click to view similar products for [LDO Voltage Regulators](#) category:*

*Click to view products by [Belling](#) manufacturer:*

Other Similar products are found below :

[M38D29FFHP#U1](#) [702103A](#) [717726C](#) [742457H](#) [MP20051DN-LF-Z](#) [R5F111PGGFB#30](#) [AP7363-SP-13](#) [NCP103AMX285TCG](#)  
[NCV8664CST33T3G](#) [NCV8752AMX28TCG](#) [L9454](#) [AP7362-HA-7](#) [LX13043CLD](#) [TCR3DF185,LM\(CT](#) [TCR3DF24,LM\(CT](#)  
[TCR3DF285,LM\(CT](#) [TCR3DF31,LM\(CT](#) [TCR3DF45,LM\(CT](#) [TLF4949EJ](#) [L9708](#) [L970813TR](#) [030014BB](#) [059985X](#) [NCP121AMX173TCG](#)  
[NCP4687DH15T1G](#) [NCV8703MX30TCG](#) [701326R](#) [702087BB](#) [755078E](#) [TCR2EN28,LF\(S](#) [LM1117DT-1.8/NO](#) [LT1086CM#TRPBF](#)  
[AZ1085S2-1.5TRE1](#) [MAX15101EWL+T](#) [NCV8170AXV250T2G](#) [SCD337BTG](#) [TCR3DF27,LM\(CT](#) [TCR3DF19,LM\(CT](#)  
[TCR3DF125,LM\(CT](#) [TCR2EN18,LF\(S](#) [MAX15103EWL+T](#) [TS2937CZ-5.0 C0](#) [MAX8878EUK30-T](#) [MAX663CPA](#) [NCV4269CPD50R2G](#)  
[NCV8716MT30TBG](#) [AZ1117IH-1.2TRG1](#) [MP2013GQ-P](#) [AP2112R5A-3.3TRG1](#) [AP7315-25W5-7](#)