



# Thin Film Chip Fuse

Document No	TCP-XXOS006H
Issued date	2012/06/28
Page	1/17

## 1. Scope

This specification applies for the fuse series of thin film chip fuse made by TA-I.

## 2. Construction

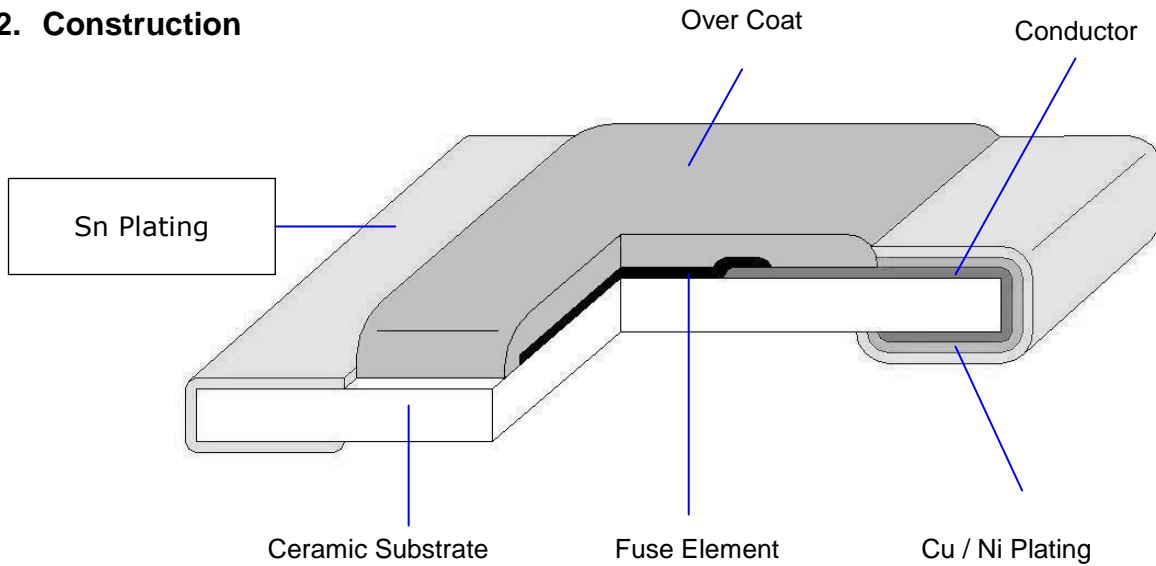

## 3. Type Designation

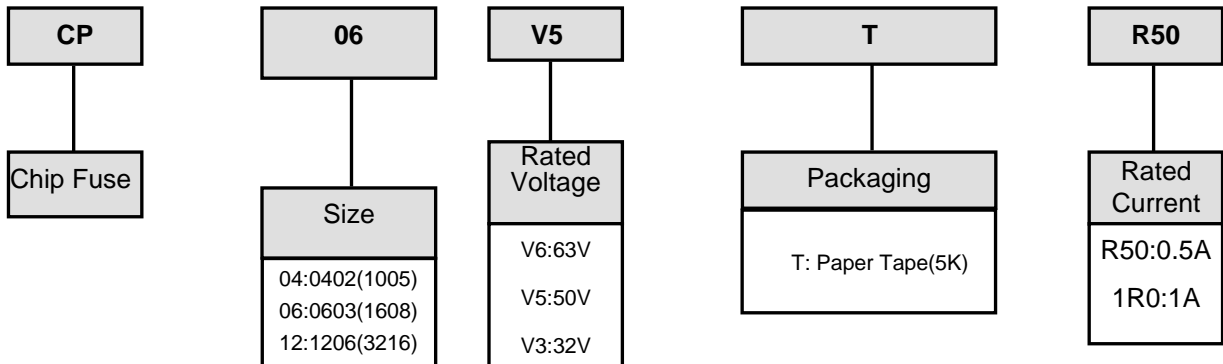



# Thin Film Chip Fuse

Document No	TCP-XXOS006H
Issued date	2012/06/28
Page	2/17

## 4. Dimensions

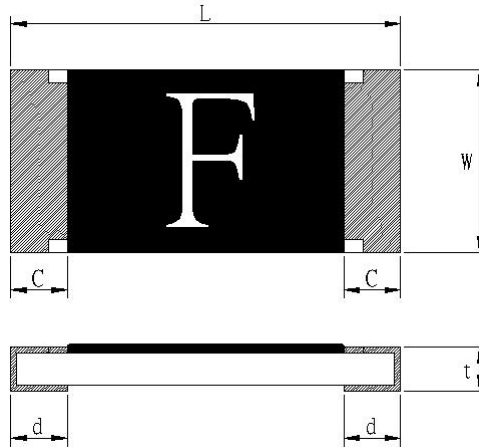

Unit: mm

Type (Inch Size code)	Dimensions (mm)				
	L	W	C	d	t
CP04V (0402)	1.0±0.1	0.52±0.05	0.2±0.1	0.25±0.1	0.35±0.05
CP06V (0603)	1.6±0.1	0.8±0.1	0.3±0.2	0.35±0.2	0.45±0.1
CP12V (1206)	3.1±0.1	1.55±0.1	0.5±0.3	0.5±0.2	0.6±0.1

## 5. Applications and ratings

Part Designation	Marking	Rated Current	Fusing Time	Resistance (mΩ) Tolerance±25%	Rated Voltage	Breaking Capacity	Body Temperature rising
CP04V3TR50	F	0.50A	Open within 5sec.at 200% rated current	380	DC 32V	DC32V 35A	<75°C at 100% rated current
CP04V3TR80	K	0.80A		120			
CP04V3T1R0	L	1.00A		95			
CP04V3T1R25	<u>M</u>	1.25A		67			
CP04V3T1R50	P	1.50A		51			
CP04V3T1R60	N	1.60A		46			
CP04V3T2R0	S	2.00A		33			
CP04V3T2R50	T	2.50A		22.5			
CP04V3T3R0	3	3.00A		20			
CP04V3T3R15	U	3.15A		19			
CP04V3T4R0	W	4.00A		16			

\*Resistance value was measured with less than 10% of rated current



# Thin Film Chip Fuse

Document No	TCP-XXOS006H
Issued date	2012/06/28
Page	3/17

Part Designation	Marking	Rated Current	Fusing Time	Resistance (mΩ) Tolerance±25%	Rated Voltage	Breaking Capacity	Body Temperature rising
CP06V5TR50	F	0.50A	Open within 5sec.at 200% rated current	260	DC 50V	DC50V 50A	<75°C at 100% rated current
CP06V3TR63	I	0.63A		218	AC/DC 32V	AC/DC32V 50A	
CP06V3TR80	K	0.80A		132			
CP06V3T1R0	L	1.00A		84.5			
CP06V3T1R25	M	1.25A		63			
CP06V3T1R50	P	1.50A		50.5			
CP06V3T1R60	N	1.60A		46			
CP06V3T2R0	S	2.00A		32			
CP06V3T2R50	T	2.50A		25.5			
CP06V3T3R00	3	3.00A		20			
CP06V3T3R15	U	3.15A		19			
CP06V3T4R0	W	4.00A		13			
CP06V3T5R0	Y	5.00A		10			
Part Designation	Marking	Rated Current	Fusing Time	Resistance (mΩ) Tolerance±25%	Rated Voltage	Breaking Capacity	Body Temperature rising
CP12V6TR50	F	0.50A	Open within 5sec.at 200% rated current	527.5	DC 63V	DC63V 50A	<75°C at 100% rated current
CP12V6TR80	K	0.80A		211			
CP12V6T1R0	L	1.00A		145.5			
CP12V6T1R25	M	1.25A		90			
CP12V6T1R50	P	1.50A		83			
CP12V6T2R0	S	2.00A		57			
CP12V3T2R50	T	2.50A		37	DC 32V	DC32V 50A	
CP12V3T3R00	3	3.00A		26			
CP12V3T4R0	W	4.00A		18			
CP12V3T5R0	Y	5.00A		13			
CP12V3T7R0	Z	7.00A		9			



# Thin Film Chip Fuse

Document No	TCP-XXOS006H
Issued date	2012/06/28
Page	4/17

## 6. Temperature Derating Curve

6.1 Normal Ambient Temperature: 25°C

6.2 Operating Temperature: -20°C~105°C, with proper Derating factor as below:

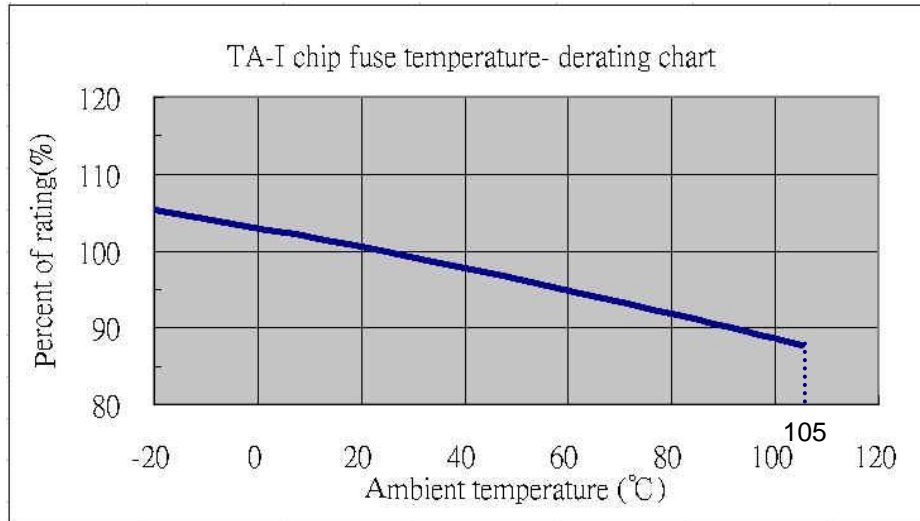

## 7. Reliability Tests

Parameter	Requirement	Test Method
Carrying capacity	No fusing	Rated current ,4hr
Fusing Time	Within 5sec.	200% of its rated current
Interrupting Ability	No mechanical damages	After the fuse is interrupted ,rated voltage applied for 30sec again
Bending Test	No mechanical damages	Distance between holding points: 90mm, Bending:3mm,1time ,30sec
Resistance to solder Heat	±20%	260°C±5°C,10seconds ±1second
Solderability	95% coverage minimum	235°C±5°C, 2±0.5second 245°C±5°C, 2±0.5second (Lead Free)
Temperature Rise	<75°C	100% of its rated current, Measure of surface temperature
Resistance to Dry Heat	±20%	105°C±5°C,1000 hrs
Resistance to Solvent	No evident damages on protective coating and marking	23°C±5°C of Isopropyl alcohol 90second
Residual Resistance	10kΩ and more	Measure DC resistance after fusing
Thermal Shock	ΔR< 10 %	-20°C/ +25°C/+125°C/+25°C , 10 cycles



# Thin Film Chip Fuse

Document No	TCP-XXOS006H
Issued date	2012/06/28
Page	5/17

## 8. Marking

Symbol for Rating Current

Symbol	F	I	K	L	M	P	N	S	T	3	U	W	Y	Z
Rating Current(A)	0.5	0.63	0.8	1	1.25	1.5	1.6	2	2.5	3	3.15	4	5	7

## 9. Taping & Reel

### 9.1 Taping Dimensions

4mm pitch paper

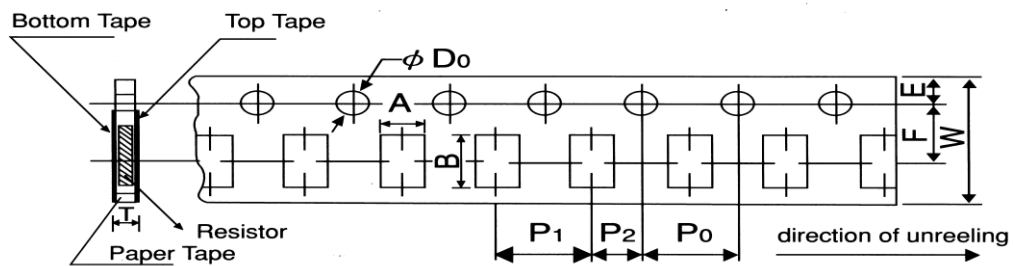

Packing	Type	A	B	W	F	E	P <sub>1</sub>	P <sub>2</sub>	P <sub>0</sub>	D <sub>0</sub>	T
Paper Tape	CP04	0.7±0.05	1.2±0.05	8.0±0.2	3.5±0.05	1.75±0.1	2.0±0.1	2.0±0.05	4.0±0.1	$\phi 1.5$ +0.1 0	0.45±0.1
Paper Tape	CP06	1.1±0.1	1.9±0.1	8.0±0.2	3.5±0.05	1.75±0.1	4.0±0.1	2.0±0.05	4.0±0.1	$\phi 1.5$ +0.1 -0	0.64±0.1
Paper Tape	CP12	2.0±0.15	3.6±0.2	8.0±0.2	3.5±0.05	1.75±0.1	4.0±0.1	2.0±0.05	4.0±0.1	$\phi 1.5$ +0.1 -0	0.84±0.1

Unit: mm

Type	Size	Paper Tape
		2 mm pitch
CP	04	180mm/R
		10000

Type series		Paper Tape
		4 mm pitch
CP	06	180mm/R
		5000
CP	12	5000



# Thin Film Chip Fuse

Document No	TCP-XXOS006H
Issued date	2012/06/28
Page	6/17

## 9.2 Reel Specifications

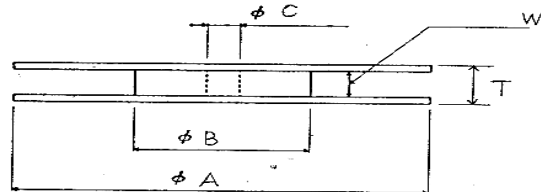
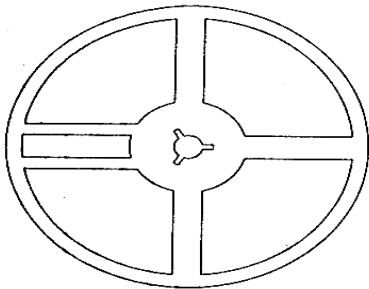

Unit: mm

Series	$\phi A$	$\phi B$	$\phi C$	W	T
CP04	178 $\pm$ 2.0	60.0 $\pm$ 1.0	13.0 $\pm$ 1.0	9.0 $\pm$ 1.0	11.4 $\pm$ 2.0
CP06					
CP12					

## 9.3 Peel –off force :

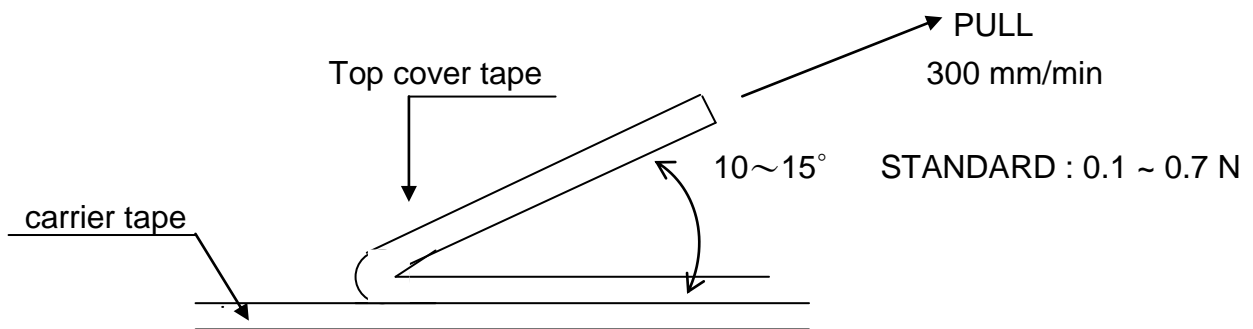

## 10. Storage Conditions:

Temperature: 5°C ~35°C, Humidity:40%~75%

## 11. Shelf Life:

2 years from manufacturing date



# Thin Film Chip Fuse

Document No	TCP-XXOS006H
Issued date	2012/06/28
Page	7/17

## 12. Label

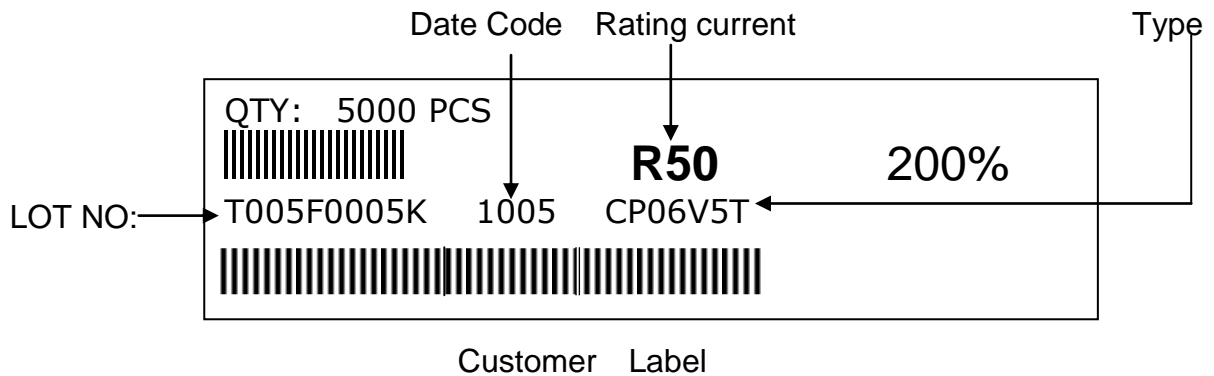

## 13. Recommended land patterns

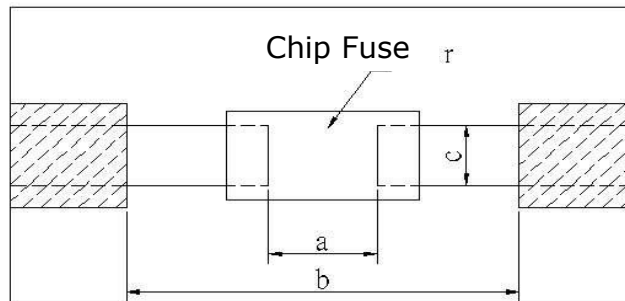

Type	Size	Land pattern		
		Dimension		
		a	b	c
CP	04 ( 0402 )	0.5~0.6	1.4~1.6	0.4~0.6
CP	06 ( 0603 )	0.7~0.9	2.0~2.2	0.8~1.0
CP	12 ( 1206 )	2.0~2.4	4.4~5.0	1.5~1.8



## 14. Recommend IR – Reflow profile : (solder : Sn96.5 / Ag3 / Cu0.5)

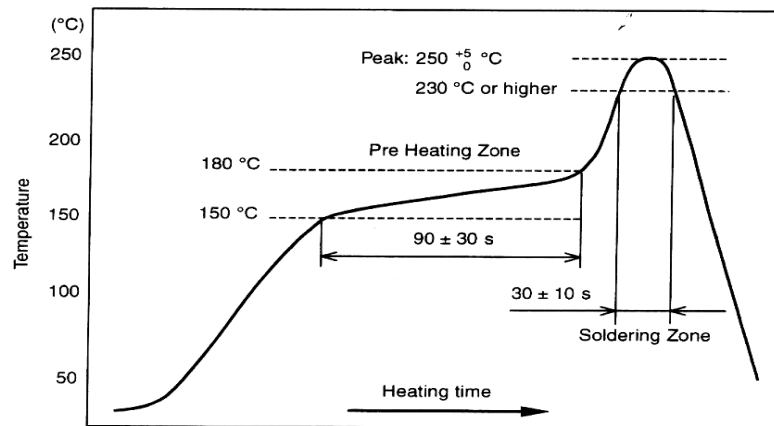

Peak :  $250 \pm 5 \text{ }^{\circ}\text{C}$  , 5 sec  
-0

Pre – heat Zone : 150 to 180 °C , 90±30 sec

Soldering Zone : 230°C or higher , 30±10 sec

## 15. Approval by UL248-14

The fuses have been approved by UL.

File No. of UL Recognition is E241710

## 16. ECN

Engineering Change Notice: The customer will be informed with ECN if there is significant modification on the characteristics and materials described in Approval Sheet.

## 17. Manufacturing Country & City :

TA-I TECHNOLOGY CO., LTD. ( Taiwan– Tao Yuan )

Tel: (+886) 3-3246169 Fax : (+886) 3-3246167

### Associated companies :

(1)TA-I TECHNOLOGY ( SU ZHOU ) CO., LTD. ( China – Su Zhou)

Tel :(+86) 512-63457879 Fax : (+86) 512-63457869

(2) TA-I TECHNOLOGY ELECTRONIC (DONGGUAN ) CO., LTD. ( China –Dongguan )

Tel : (+86) 769-8339-4790~3 Fax : (+86) 769-8339-4794

(3) FORTUNE TASK RESISTOR FACTORY ( China – Dongguan )

Tel : (+86) 769-8339-4790~3 Fax : (+86) 769-8339-4794

(4) TAI OHM ELECTRONICS ( M ) SDN. BHD. ( Malaysia – Penang )

Tel :(+60) 4- 3900480 Fax : (+60) 4-3901481

(5) P.T.TAI ELECTRONIC Indonesia ( Indonesia – Jakarta )

Tel :(+62) 21-89830123 Fax : (+62) 21-89830703





Document No	TCP-XXOS006H
Issued date	2012/06/28
Page	9/17

## Selection Guideline of Fuse:

### ■ Checklist of selection factors

- ⊙ Normal operating current
- ⊙ Normal operating voltage ( AC or DC )
- ⊙ Ambient Temperature
- ⊙ Overload current and length of time in which the fuse must open .
- ⊙ Type of fuse ( SMD or Tube ) and physical size limitation ( 0603 or 1206 )
- ⊙ Agency Approval required ( e.g., UL248-14 )

### ■ Normal operating current

e.g., Rectangular Wave , If  $I_p = 1.5 A$  , Normal operating current = 1.5 A

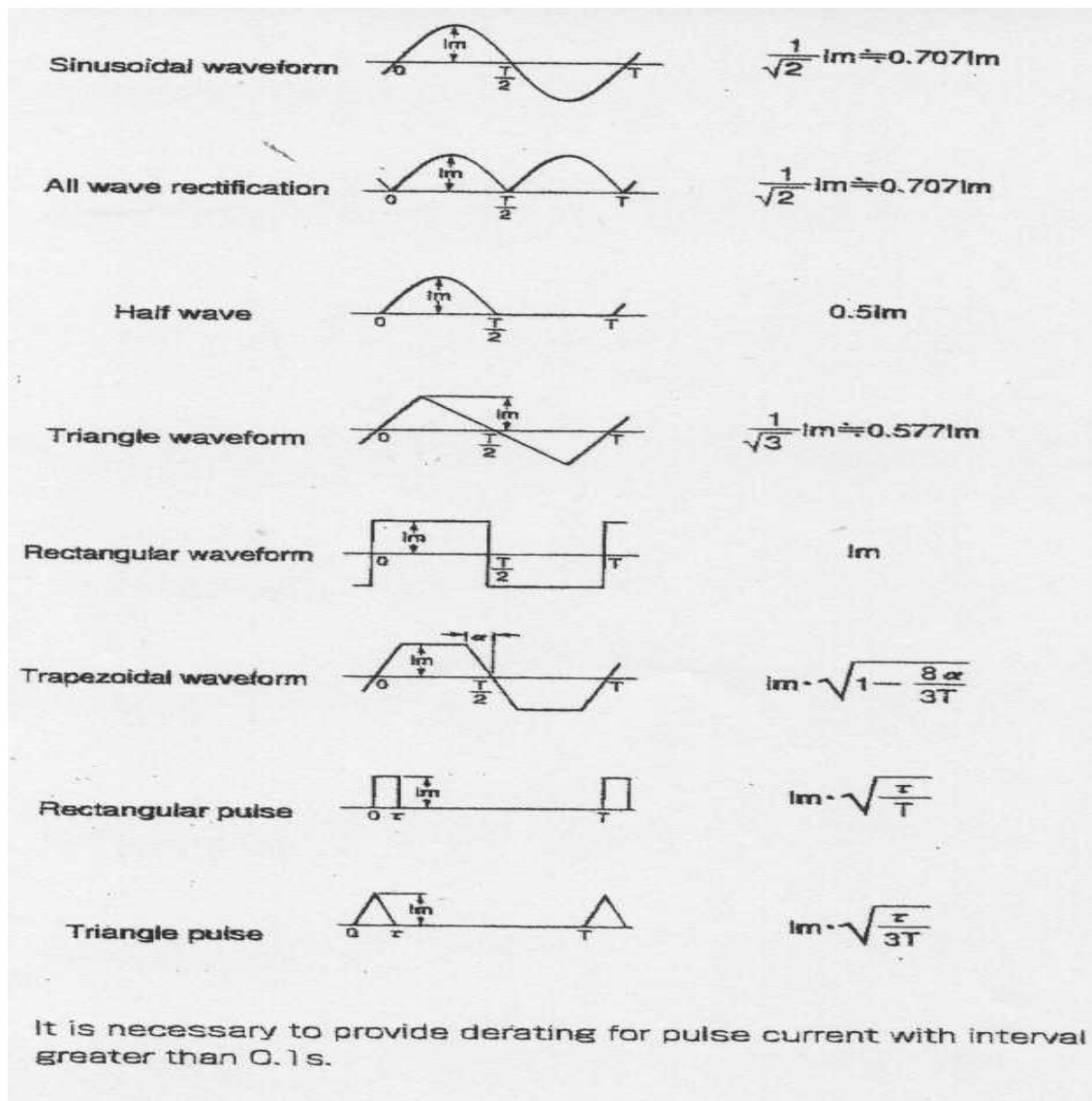



# Thin Film Chip Fuse

Document No	TCP-XXOS006H
Issued date	2012/06/28
Page	10/17

## Derating ratio for different ambient Temperature

- Referring to bottom figure and select the appropriate derating ratio :  
 e.g., Ambient temperature is 60 degree C  
 the derating ratio  $\approx$  0.95

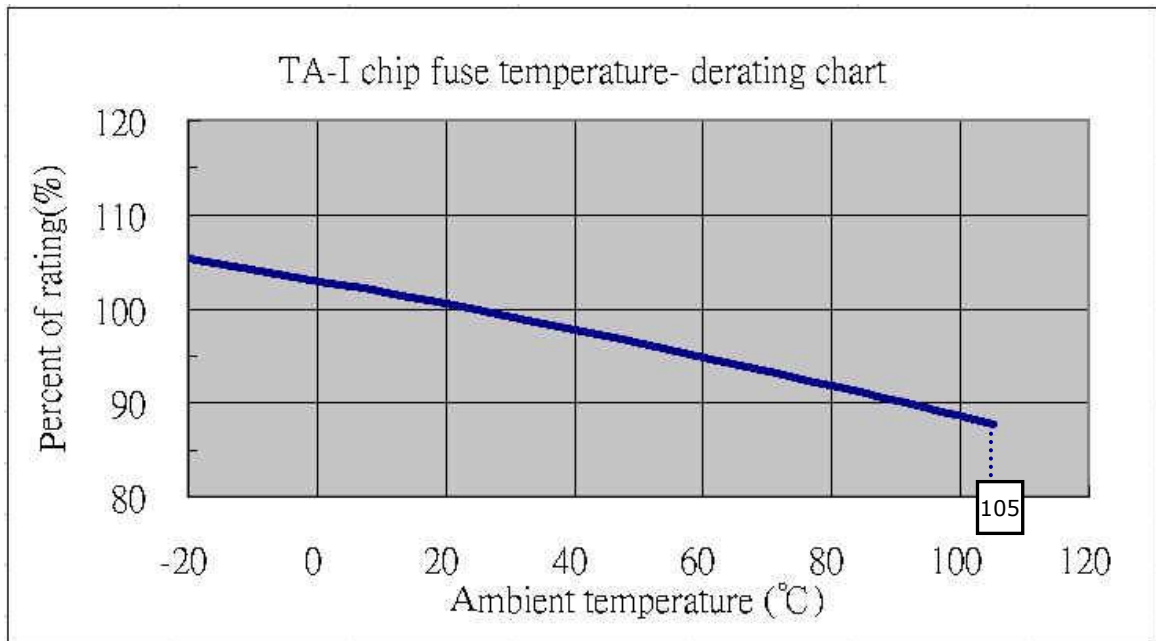

## Calculating the required rating of fuse needed .

- Safety coefficient : 70 % is safety coefficient from practical experience

$$\frac{\text{Normal Operating Current}}{0.7 \times \text{derating ratio}} < \text{rating current of fuse}$$

$\swarrow$  Safety coefficient       $\searrow$  Ambient temperature

e.g.,

Condition : Normal operating current =1.5 A  
 Ambient temperature 40 °C : Derating ratio  $\approx$  0.95

$$\frac{1.5}{0.7 \times 0.95} < \text{rating current of fuse}$$

**2.255 < rating current of fuse**



# Thin Film Chip Fuse

Document No	TCP-XXOS006H
Issued date	2012/06/28
Page	11/17

## ■ Determination of the type of fuse

e.g., Condition :

- ◆ Calculating value = 2.255 A , 2.255A < rating current of fuse
- ◆ Normal operating voltage : DC 12 V
- ◆ Following bottom index-table :

Suggesting use CP06V3T2R50 .

Part Designation	Marking	Rated Current	Rated Voltage	Part Designation	Marking	Rated Current	Rated Voltage
CP06V5TR50	F	0.50A	50V	CP12V6TR50	F	0.50A	63V
CP06V3TR63	I	0.63A	32V	CP12V6TR80	K	0.80A	63V
CP06V3TR80	K	0.80A	32V	CP12V6T1R0	L	1.00A	63V
CP06V3T1R0	L	1.00A	32V	CP12V6T1R25	<u>M</u>	1.25A	63V
CP06V3T1R25	<u>M</u>	1.25A	32V	CP12V6T1R50	P	1.50A	63V
CP06V3T1R50	P	1.50A	32V	CP12V6T2R0	S	2.00A	63V
CP06V3T1R60	N	1.60A	32V	CP12V3T2R50	T	2.50A	32V
CP06V3T2R0	S	2.00A	32V	CP12V3T3R00	3	3.00A	32V
CP06V3T2R50	T	2.50A	32V	CP12V3T4R0	W	4.00A	32V
CP06V3T3R00	3	3.00A	32V	CP12V3T5R0	Y	5.00A	32V
CP06V3T3R15	U	3.15A	32V	CP12V3T7R0	Z	7.00A	32V
CP06V3T4R0	W	4.00A	32V				
CP06V3T5R0	Y	5.00A	32V				

## ■ Inrush current :

- ◆ Considering inrush waveform & calculate  $I^2t$  (A<sup>2</sup>s) value
- ◆ Choosing fuse's  $I^2t$  (A<sup>2</sup>s) value > calculate  $I^2t$  (A<sup>2</sup>s) value
- ◆ Considering Ratio of  $I^2t$  repeat numbers to blowing
- ◆ Confrim with us

e.g., choosing 0603 Fuse

Condition :

1. Rectangular Wave ,  $I_p = 4$  A ,  $t = 1$  ( ms ) ,

$$\text{Calculate } I_p^2t = 4^2 \times 1 \times 10^{-3} \text{ (A)} = 0.016 \text{ (A}^2\text{s)}$$

2. Choosing CP06V3T2R50 (  $I^2t = 0.1807$  (A<sup>2</sup>s) )  $\implies$  Page 12 index-table

3. Inrush shock : 100,000 times (  $\approx 0.35$  )  $\implies$  Inrush derating ratio

Calculating :

$\curvearrowright$  Inrush 100,000 times

1. Choosing fuse's  $I^2t$  (A<sup>2</sup>s) value X Derating ratio > calculate  $I^2t$  (A<sup>2</sup>s) value

$$2. 0.1807 \times 0.35 = 0.0632 \text{ (A}^2\text{s)}$$

4. 0.0632 > 0.016



# Thin Film Chip Fuse

Document No	TCP-XXOS006H
Issued date	2012/06/28
Page	12/17

## The fuse is able to meet circuit 's application

TA-I FUSE $I^2t$ (A <sup>2</sup> s)					
Part Number	Typical $I^2t$ (A <sup>2</sup> s)	Part Number	Typical $I^2t$ (A <sup>2</sup> s)	Part Number	Typical $I^2t$ (A <sup>2</sup> s)
CP04V3TR315	0.00203	CP06V5TR50	0.0088	CP12V6TR50	0.015
CP04V3TR50	0.00317	CP06V3TR63	0.0125	CP12V6TR80	0.040
CP04V3TR75	0.00402	CP06V3TR80	0.0206	CP12V6T1R0	0.062
CP04V3TR80	0.00532	CP06V3T1R0	0.0211	CP12V6T1R25	0.094
CP04V3T1R0	0.00724	CP06V3T1R25	0.0472	CP12V6T1R50	0.141
CP04V3T1R25	0.01344	CP06V3T1R50	0.0623	CP12V6T2R0	0.285
CP04V3T1R50	0.01356	CP06V3T1R60	0.0817	CP12V3T2R50	0.445
CP04V3T1R60	0.01672	CP06V3T2R0	0.1176	CP12V3T3R00	0.639
CP04V3T2R0	0.01983	CP06V3T2R50	0.1807	CP12V3T4R0	1.109
CP04V3T2R50	0.03763	CP06V3T3R00	0.3177	CP12V3T5R0	1.710
CP04V3T3R00	0.05427	CP06V3T3R15	0.3615	CP12V3T7R0	3.300
CP04V3T3R15	0.06304	CP06V3T4R0	0.5348		
CP04V3T4R0	0.08960	CP06V3T5R0	0.7726		

Note\*: Typical  $I^2t$  value is measured at 10x-rated current, Application with surge over 10x-rated current.  
Please confirm with us.

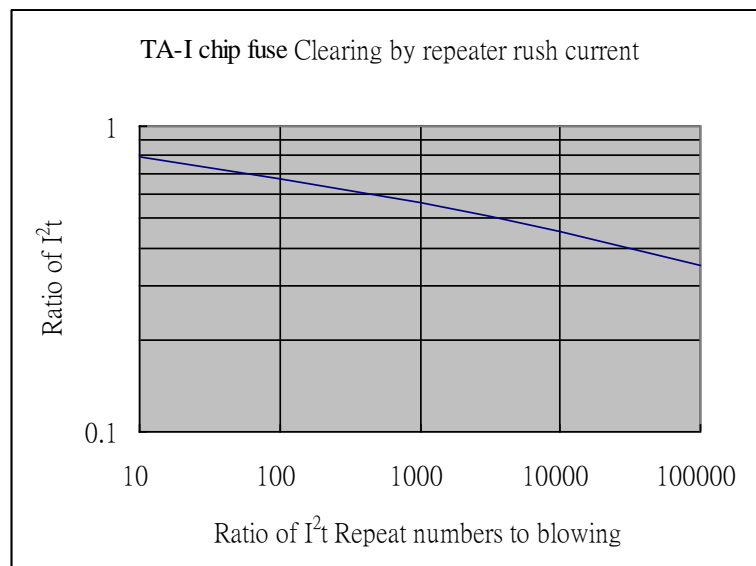



## Inrush Waveform

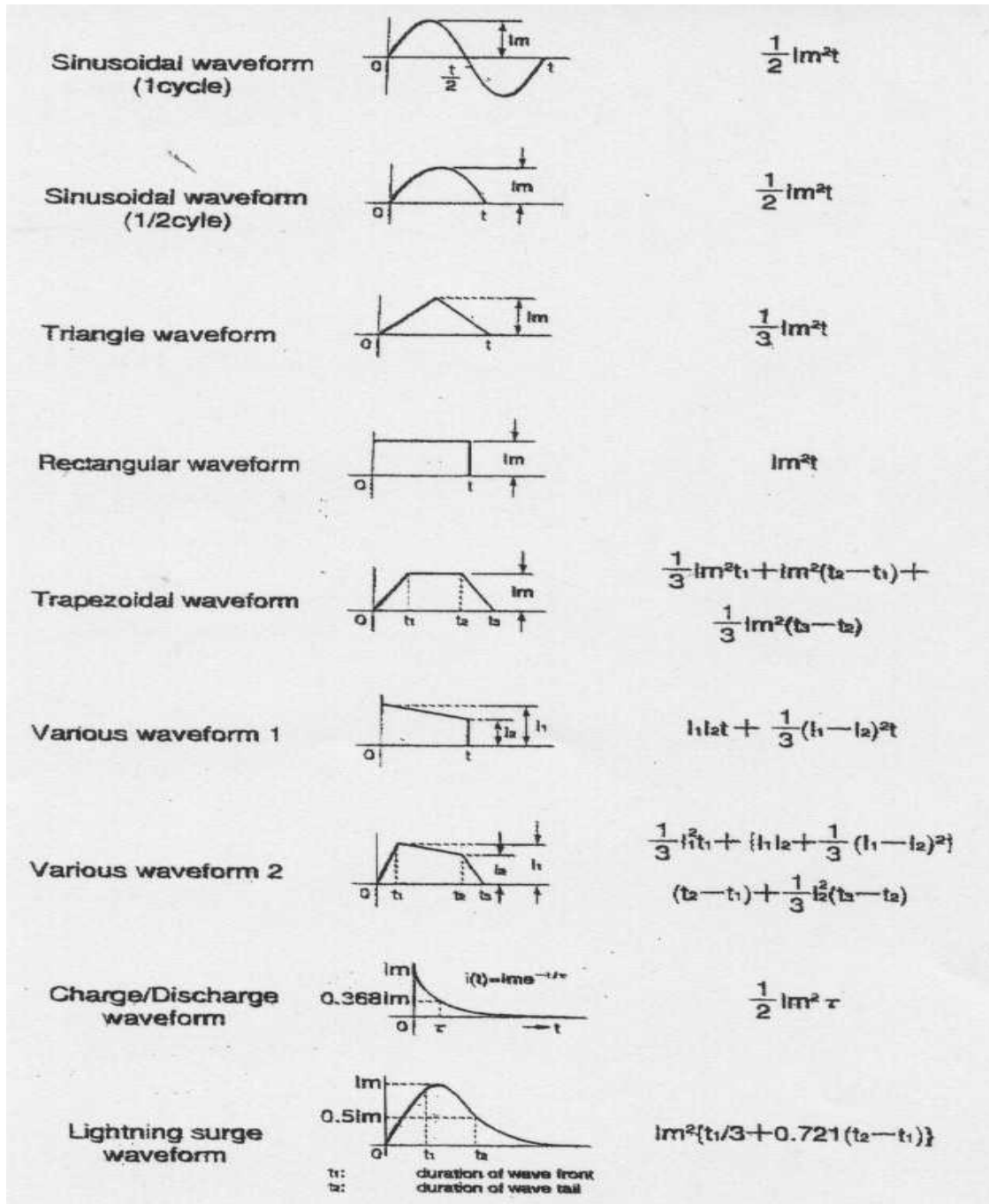



# Thin Film Chip Fuse

Document No	TCP-XXOS006H
Issued date	2012/06/28
Page	14/17

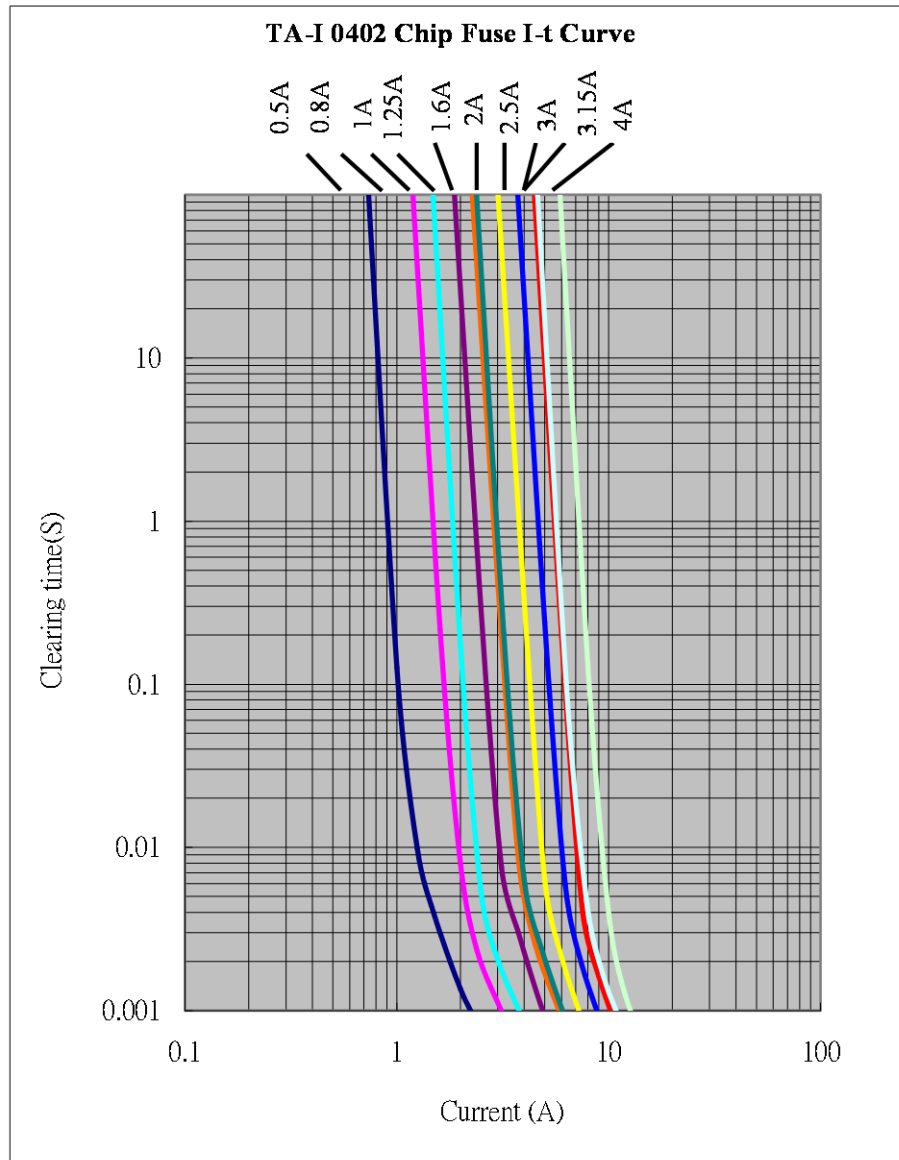



# Thin Film Chip Fuse

Document No	TCP-XXOS006H
Issued date	2012/06/28
Page	15/17

TA-I 0402 Chip Fuse I<sup>2</sup>-t Curve

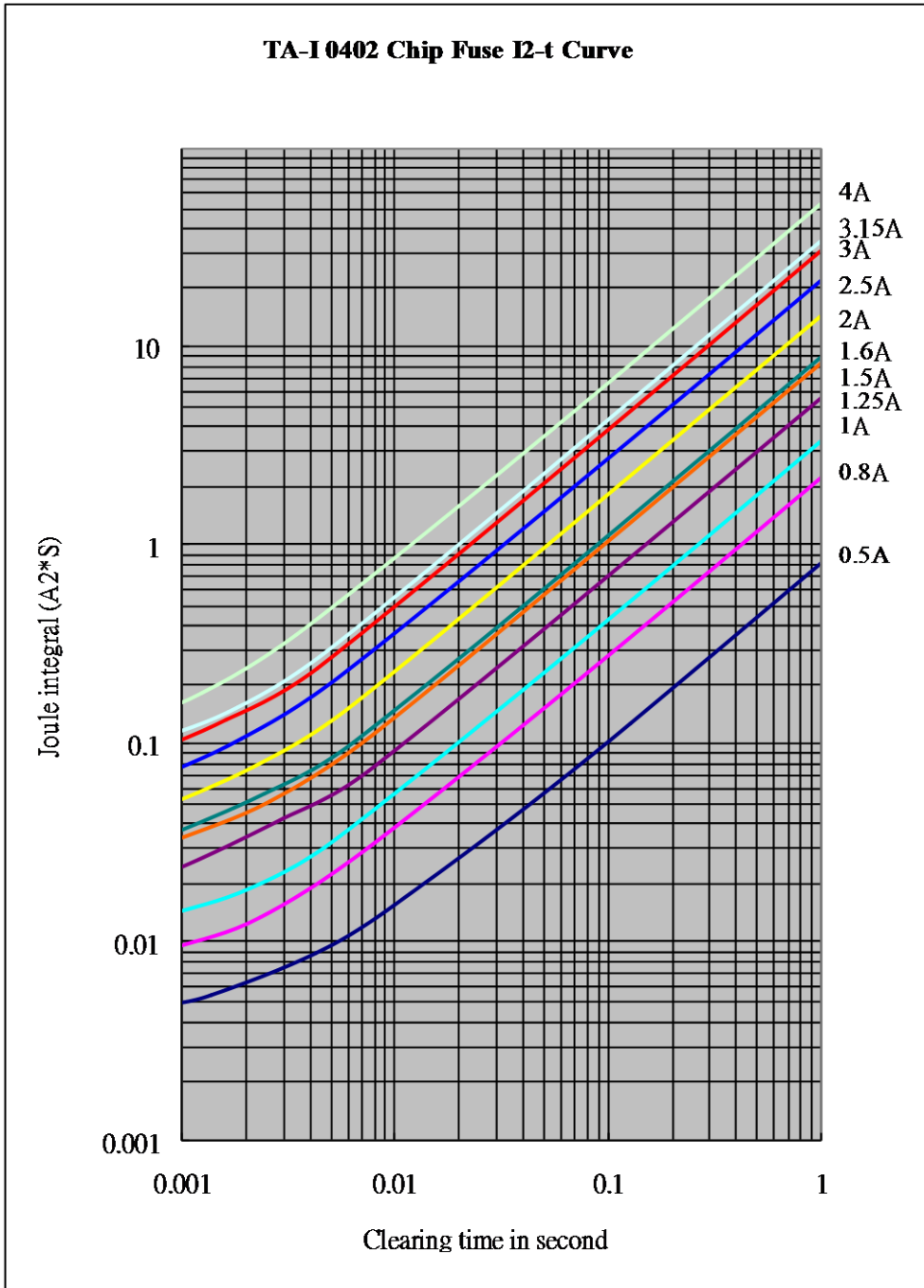



# Thin Film Chip Fuse

Document No	TCP-XXOS006H
Issued date	2012/06/28
Page	16/17

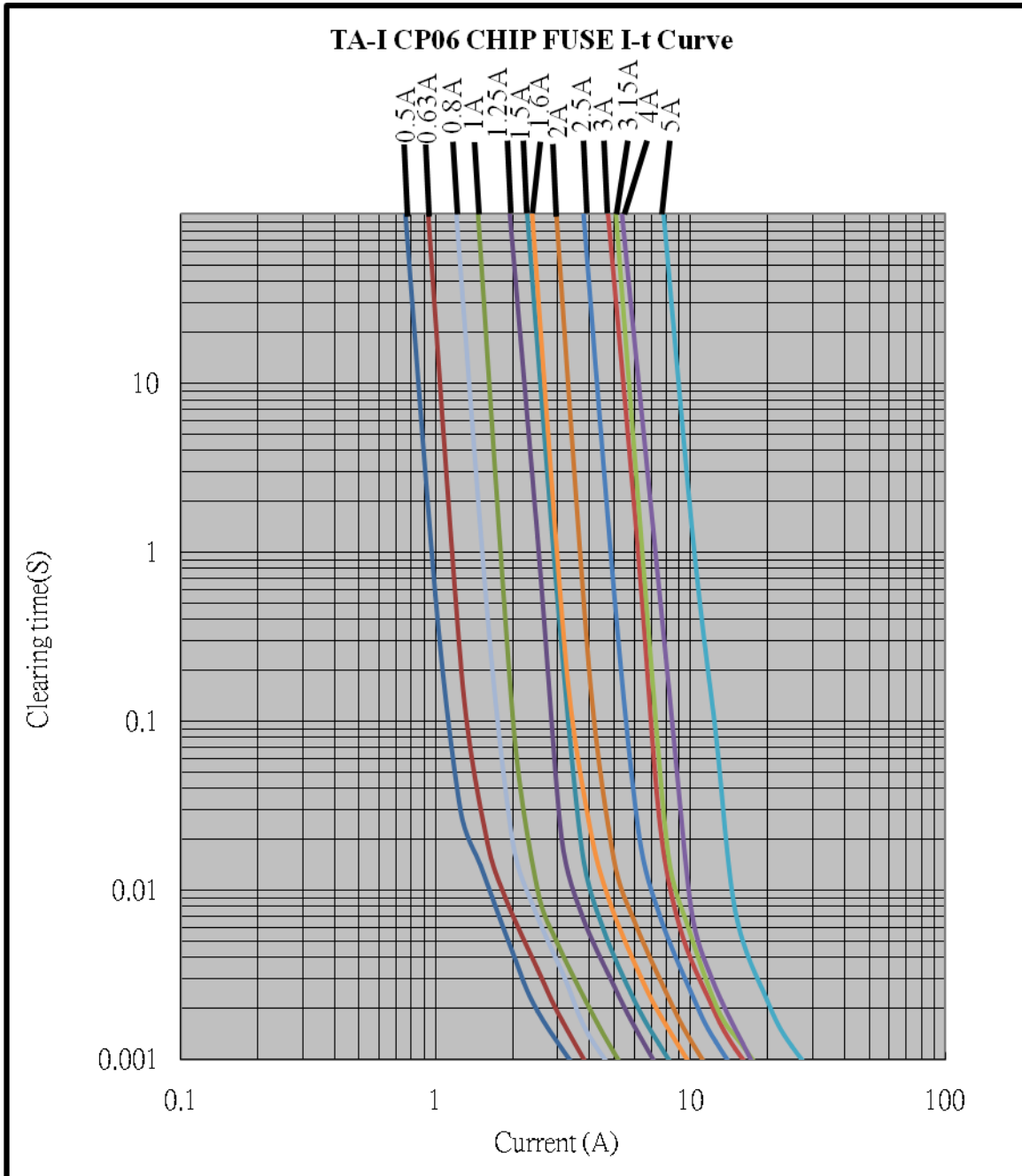





# Thin Film Chip Fuse

Document No	TCP-XXOS006H
Issued date	2012/06/28
Page	17/17

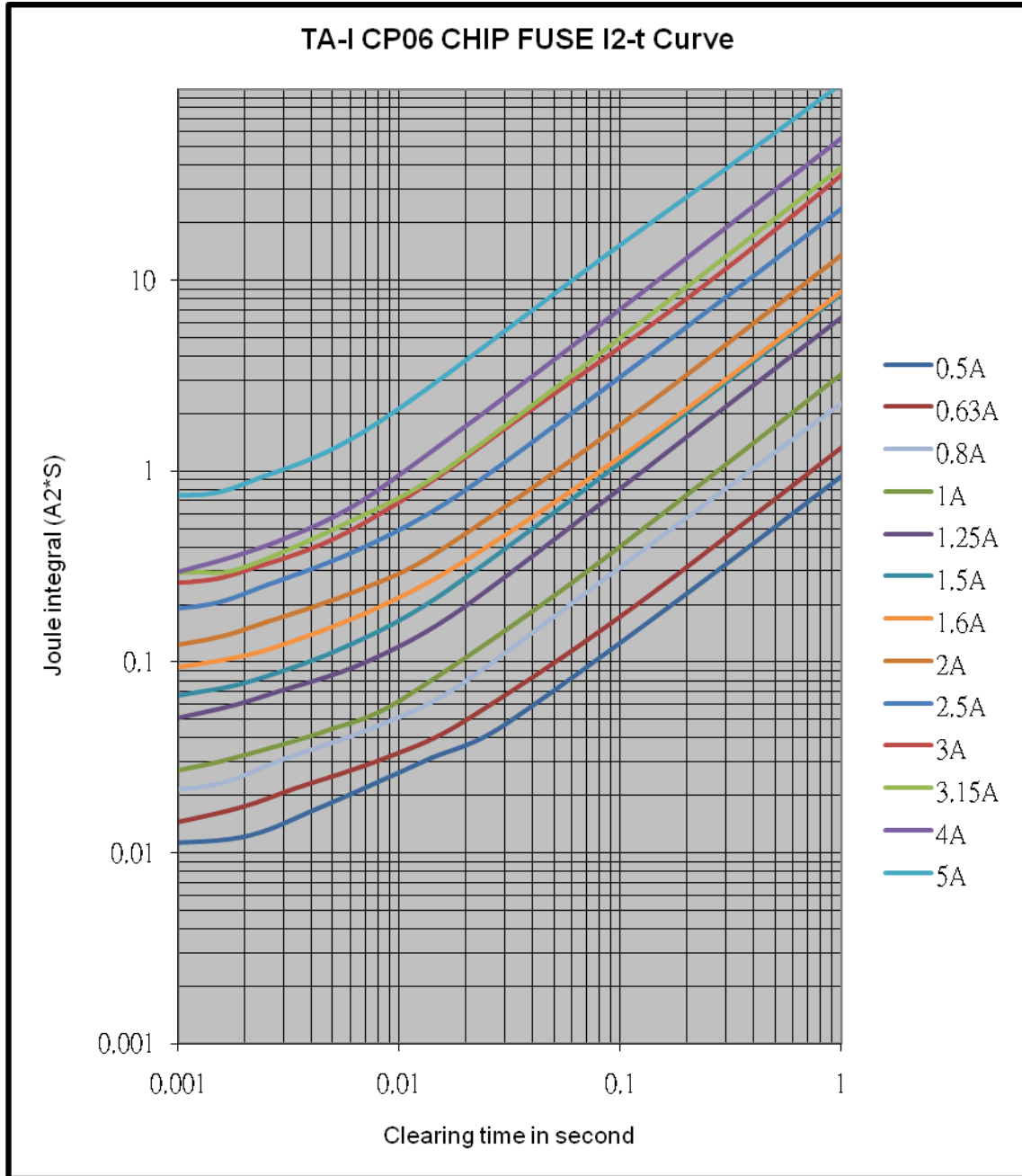

## X-ON Electronics

Largest Supplier of Electrical and Electronic Components

*Click to view similar products for [Surface Mount Fuses](#) category:*

*Click to view products by [TA-I Tech](#) manufacturer:*

Other Similar products are found below :

[FHC20402ADTP](#) [FT600-0500-2](#) [NFVC6125S0R50TRF](#) [SFT-125MA](#) [TF16SN2.00TTD](#) [TF16SN3.15TTD](#) [41921000000](#) [TR/3216LR-500MA](#) [CCP2B20TTE](#) [TR-3216FF4-R](#) [SST 1-1K](#) [SST 5 -1K](#) [SST 2-1K](#) [TR2-TCP500-R](#) [F60C500V12AS](#) [FCC16501ABTP](#) [FCC16102ABTP](#) [FHC16322ADTP](#) [0308.250UR](#) [0308.375UR](#) [0308.500UR](#) [0308.750UR](#) [0308001.UR](#) [030801.5UR](#) [FCC16202ABTP](#) [3-122-714](#) [3-122-720](#) [3-122-718](#) [3-122-712](#) [3-122-716](#) [03081.25UR](#) [CQ06LF 5A 32V](#) [CQ06LT 5A 32V](#) [SET 2A 125V \(G\)](#) [SET 1A 125V \(G\)](#) [SEF 10A 125V \(G\)](#) [SEF 3A 125V \(G\)](#) [SEF 4A 125V \(G\)](#) [SEF 6A 125V \(G\)](#) [SEF 7A 125V \(G\)](#) [SET 4A 125V \(G\)](#) [SET 3A 125V \(G\)](#) [SET 5A 125V \(G\)](#) [SET 7A 125V \(G\)](#) [F0603G0R03FNTR](#) [SKY87604-12](#) [SKY87604-11](#) [SKY87604-13](#) [0154002.DRL](#) [0154008.DRL](#)