

# APPROVAL SHEET

## MULTILAYER CERAMIC CAPACITORS

Middle & High Voltage Series (200V to 3kV)

0603 to 1812 Sizes

NP0, X7R & Y5V Dielectrics

RoHS compliance

\*Contents in this sheet are subject to change without prior notice.

## 1. INTRODUCTION

WTC middle and high voltage series MLCC is designed by a special internal electrode pattern, which can reduce voltage concentrations by distributing voltage gradients throughout the entire capacitor. This special design also affords increased capacitance values in a given case size and voltage rating.

Chips size 1206 and larger to use on reflow soldering process only. Capacitors with X7R dielectrics are not intended for AC line filtering applications. Capacitors may require protective surface coating to prevent external arcing.

## 2. FEATURES

- High voltage in a given case size.
- High stability and reliability.

## 3. APPLICATIONS

- Snubbers in high frequency power converters.
- High voltage coupling/DC blocking.
- DC-DC converters.
- Back-lighting inverters

## 4. HOW TO ORDER

<u>1808</u>	<u>N</u>	<u>100</u>	<u>J</u>	<u>202</u>	<u>C</u>	<u>I</u>
<u>Size</u>	<u>Dielectric</u>	<u>Capacitance</u>	<u>Tolerance</u>	<u>Rated voltage</u>	<u>Termination</u>	<u>Packaging</u>
Inch (mm) <b>0603</b> (1608) <b>0805</b> (2012) <b>1206</b> (3216) <b>1210</b> (3225) <b>1808</b> (4520) <b>1812</b> (4532)	<b>N</b> =NP0 (C0G) <b>B</b> =X7R <b>F</b> =Y5V	Two significant digits followed by no. of zeros. And R is in place of decimal point.  eg.: 0R5=0.5pF 1R0=1.0pF 100=10x10 <sup>0</sup> =10pF	<b>B</b> =±0.1pF <b>C</b> =±0.25pF <b>D</b> =±0.5pF <b>F</b> =±1% <b>G</b> =±2% <b>J</b> =±5% <b>K</b> =±10% <b>M</b> =±20% <b>Z</b> =-20/+80%	Two significant digits followed by no. of zeros. And R is in place of decimal point.  <b>201</b> =200 VDC <b>251</b> =250 VDC <b>501</b> =500 VDC <b>631</b> =630 VDC <b>102</b> =1000 VDC <b>152</b> =1500 VDC <b>202</b> =2000 VDC <b>252</b> =2500 VDC <b>302</b> =3000 VDC	<b>C</b> =Cu/Ni/Sn (for NP0, X7R, Y5V dielectric)	<b>T</b> =7" reeled <b>G</b> =13" reeled

\* Partial NP0 items are with Ag/Ni/Sn terminations, please ref to below product range of NP0 dielectric for detail.

## 5. EXTERNAL DIMENSIONS

Size Inch (mm)	L (mm)	W (mm)	T (mm)/Symbol	Remark	M <sub>B</sub> (mm)	
0603(1608)	1.60±0.10	0.80±0.10	0.80±0.07	S	0.40±0.15	
	1.60 +0.15/-0.10	0.80 +0.15/-0.10	0.80 +0.15/-0.10	X		
0805 (2012)	2.00±0.15	1.25±0.10	0.60±0.10	A	0.50±0.20	
			0.80±0.10	B		
			1.25±0.10	D		#
1206 (3216)	3.20±0.15	1.60±0.15	0.80±0.10	B	0.60±0.20 (0.5±0.25)*	
			0.95±0.10	C		
			1.25±0.10	D		#
			1.60±0.20	G		#
1210 (3225)	3.20±0.30	2.50±0.20	0.95±0.10	C	0.75±0.25	
			1.25±0.10	D		#
	3.20±0.40	2.50±0.30	1.60±0.20	G		#
			2.00±0.20	K		#
			2.50±0.30	M		#
1808 (4520)	4.50+0.5/-0.3	2.03±0.25	1.25±0.10	D	0.50±0.25	
			2.00±0.20	K		#
1812 (4532)	4.50+0.5/-0.3	3.20±0.30	1.25±0.10	D	0.50±0.25	
			1.60±0.20	G		#
		3.20±0.40	2.00±0.20	K		#
			2.80±0.30	U		#

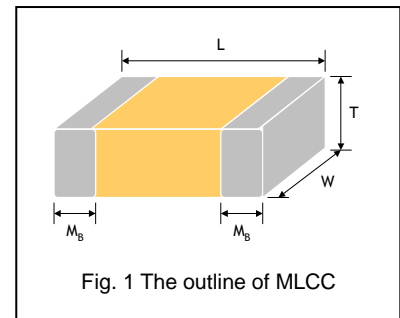

# Reflow soldering only is recommended.

\* For 1206\_1000V ~3000V products.

## 6. GENERAL ELECTRICAL DATA

Dielectric	NP0	X7R	Y5V
Size	0603, 0805, 1206, 1210, 1808, 1812		0805, 1206, 1210, 1812
Capacitance*	0.5pF to 0.01μF		100pF to 1.0μF
Capacitance tolerance***	Cap≤5pF: C (±0.25pF) 5pF<Cap<10pF: D (±0.5pF) Cap≥10pF: F (±1%), G (±2%), J (±5%),K (±10%)		0.01μF to 0.68μF
Rated voltage (WVDC)	200V to 3kV		200V, 250V
Q/DF*	Cap<30pF: Q≥400+20C Cap≥30pF: Q≥1000		DF≤5%
Insulation resistance at U <sub>r</sub> **	U <sub>r</sub> =200~630V: ≥10GΩ or R <sub>x</sub> C≥100Ω·F whichever is smaller U <sub>r</sub> =1000~3000V: ≥10GΩ		
Dielectric strength	200~300V: ≥2 x WVDC 500~999V: ≥1.5 x WVDC 1000~3000V: ≥1.2 x WVDC		
Operating temperature	-55 to +125°C		-25 to +85°C
Capacitance characteristic	±30ppm	±15%	+30/-80%
Termination	Ni/Sn (lead-free termination)		

\* Measured at the condition of 30~70% related humidity.

NP0: Apply 1.0±0.2Vrms, 1.0MHz±10% for Cap≤1000pF and 1.0±0.2Vrms, 1.0kHz±10% for Cap>1000pF, 25°C at ambient temperature

X7R, X5R: Apply 1.0±0.2Vrms, 1.0kHz±10%, at 25°C ambient temperature.

Y5V: Apply 1.0±0.2Vrms, 1.0kHz±10%, at 20°C ambient temperature.

\*\* Preconditioning for Class II MLCC: Perform a heat treatment at 150±10°C for 1 hour, then leave in ambient condition for 24±2 hours before measurement.

## 7. CAPACITANCE RANGE (MIDDLE VOLTAGE - 200V to 630V)

### 7-1 NP0 Dielectric

DIELECTRIC		NP0																				
SIZE		0603		0805				1206				1210				1808		1812				
RATED VOLTAGE (VDC)		200	250	200	250	500	630	200	250	500	630	200	250	500	630	500	630	200	250	500	630	
0.5pF (0R5)		S	S	A	A	A	A															
1.0pF (1R0)		S	S	A	A	A	A															
1.2pF (1R2)		S	S	A	A	A	A															
1.5pF (1R5)		S	S	A	A	A	A	B	B	B	B											
1.8pF (1R8)		S	S	A	A	A	A	B	B	B	B					D	D					
2.2pF (2R2)		S	S	A	A	A	A	B	B	B	B					D	D					
2.7pF (2R7)		S	S	A	A	A	A	B	B	B	B					D	D					
3.3pF (3R3)		S	S	A	A	A	A	B	B	B	B					D	D					
3.9pF (3R9)		S	S	A	A	A	A	B	B	B	B					D	D					
4.7pF (4R7)		S	S	A	A	A	A	B	B	B	B					D	D					
5.6pF (5R6)		S	S	A	A	A	A	B	B	B	B					D	D					
6.8pF (6R8)		S	S	A	A	A	A	B	B	B	B					D	D					
8.2pF (8R2)		S	S	A	A	A	A	B	B	B	B					D	D					
10pF (100)		S	S	A	A	A	A	B	B	B	B	C	C	C	C	D	D	D	D	D	D	D
12pF (120)		S	S	A	A	A	A	B	B	B	B	C	C	C	C	D	D	D	D	D	D	D
15pF (150)		S	S	A	A	A	A	B	B	B	B	C	C	C	C	D	D	D	D	D	D	D
18pF (180)		S	S	A	A	A	A	B	B	B	B	C	C	C	C	D	D	D	D	D	D	D
22pF (220)		S	S	A	A	A	A	B	B	B	B	C	C	C	C	D	D	D	D	D	D	D
27pF (270)		S	S	A	A	A	A	B	B	B	B	C	C	C	C	D	D	D	D	D	D	D
33pF (330)		S	S	A	A	A	A	B	B	B	B	C	C	C	C	D	D	D	D	D	D	D
39pF (390)		S	S	A	A	A	A	B	B	B	B	C	C	C	C	D	D	D	D	D	D	D
47pF (470)		S	S	A	A	A	A	B	B	B	B	C	C	C	C	D	D	D	D	D	D	D
56pF (560)		S	S	A	A	A	A	B	B	B	B	C	C	C	C	D	D	D	D	D	D	D
68pF (680)		S	S	A	A	A	A	B	B	B	B	C	C	C	C	D	D	D	D	D	D	D
82pF (820)		S	S	A	A	B	B	B	B	B	B	C	C	C	C	D	D	D	D	D	D	D
100pF (101)		S	S	A	B	B	B	B	B	B	B	C	C	C	C	D	D	D	D	D	D	D
120pF (121)		S	S	A	B	D	D	B	B	B	B	C	C	C	C	D	D	D	D	D	D	D
150pF (151)		S	S	B	D	D	D	B	B	B	B	C	C	C	C	D	D	D	D	D	D	D
180pF (181)		S	S	B	D	D	D	B	B	B	B	C	C	C	C	D	D	D	D	D	D	D
220pF (221)		S	S	D	D	D	D	B	B	B	B	C	C	C	C	D	D	D	D	D	D	D
270pF (271)		X	X	D	D	D	D	B	C	C	C	C	C	C	C	K	K	D	D	D	D	D
330pF (331)		X	X	D	D	D	D	B	C	C	C	C	C	C	C	K	K	D	D	D	D	D
390pF (391)		X	X	D	D	D	D	B	C	C	C	C	C	C	C	K	K	D	D	D	D	D
470pF (471)		X	X	D	D	I	I	C	C	C	C	C	C	C	C	K	K	D	D	D	D	D
560pF (561)				D	D	I	I	C	D	D	D	C	C	C	C	K	K	D	D	D	D	D
680pF (681)				D	D	I	I	C	D	D	D	C	C	C	C	K	K	D	D	D	D	D
820pF (821)				D	D	I	I	C	G	G	G	C	C	C	C	K	K	D	D	D	D	D
1,000pF (102)				D	D	I	I	C	G	G	G	D	D	D	D	K	K	D	D	D	D	D
1,200pF (122)				D	D			C	G	G	G	D	D	D	D	K	K	D	D	D	D	D
1,500pF (152)				D	D			D	G	G	G	D	D	D	D	K	K	D	D	D	D	D
1,800pF (182)				D	D			D	G	G	G	D	D	D	D	K	K	D	D	D	D	D
2,200pF (222)				D	D			D	G	G	G	D	D	D	D	K	K	D	D	D	D	D
2,700pF (272)								D	G			D	D	D	D			D	D	D	D	D
3,300pF (332)								D	G			D	D	D	D			D	D	D	D	D
3,900pF (392)								D	G			D	D	D	D			D	D			
4,700pF (472)								D	G			G	G					D	D			
5,600pF (562)												G	G					D	D			
6,800pF (682)												G	G					D	D			
8,200pF (822)												G	G									
0.01µF (103)												G	G									

1. The letter in cell is expressed the symbol of product thickness.

7-2 X7R Dielectric

DIELECTRIC		X7R																			
SIZE		0603		0805				1206				1210				1808		1812			
RATED VOLTAGE (VDC)		200	250	200	250	500	630	200	250	500	630	200	250	500	630	500	630	200	250	500	630
Capacitance	100pF (101)	X	X	B	B	B	B	D	D	D	D	D	D	D	D	D					
	120pF (121)	X	X	B	B	B	B	D	D	D	D	D	D	D	D	D					
	150pF (151)	X	X	B	B	B	B	D	D	D	D	D	D	D	D	D	D				
	180pF (181)	X	X	B	B	B	B	D	D	D	D	D	D	D	D	D	D				
	220pF (221)	X	X	B	B	B	B	D	D	D	D	D	D	D	D	D	D				
	270pF (271)	X	X	B	B	B	B	D	D	D	D	D	D	D	D	D	D				
	330pF (331)	X	X	B	B	B	B	D	D	D	D	D	D	D	D	D	D				
	390pF (391)	X	X	B	B	B	B	D	D	D	D	D	D	D	D	D	D				
	470pF (471)	X	X	B	B	B	B	D	D	D	D	D	D	D	D	D	D				
	560pF (561)	X	X	B	B	B	B	D	D	D	D	D	D	D	D	D	D				
	680pF (681)	X	X	B	B	B	B	D	D	D	D	C	C	C	D	D	D				
	820pF (821)	X	X	B	B	B	B	D	D	D	D	C	C	C	D	D	D				
	1,000pF (102)	X	X	B	B	B	B	D	D	D	D	C	C	C	D	D	D	D	D	D	D
	1,200pF (122)	X	X	B	B	B	B	D	D	D	D	C	C	C	D	D	D	D	D	D	D
	1,500pF (152)	X	X	B	B	B	B	D	D	D	D	C	C	C	D	D	D	D	D	D	D
	1,800pF (182)	X	X	B	B	B	B	D	D	D	D	C	C	C	D	D	D	D	D	D	D
	2,200pF (222)	X	X	B	B	B	B	D	D	D	D	C	C	C	D	D	D	D	D	D	D
	2,700pF (272)	X	X	B	B	B	B	D	D	D	D	C	C	C	D	D	D	D	D	D	D
	3,300pF (332)	X	X	B	B	B	B	D	D	D	D	C	C	C	D	D	D	D	D	D	D
	3,900pF (392)	X	X	B	B	B	B	D	D	D	D	C	C	C	D	D	D	D	D	D	D
	4,700pF (472)	X	X	B	B	D	D	D	D	D	D	C	C	C	D	D	D	D	D	D	D
	5,600pF (562)	X	X	D	D	D	D	D	D	D	D	C	C	C	D	D	K	K	D	D	D
	6,800pF (682)	X	X	D	D	D	D	D	D	D	D	C	C	C	D	D	K	K	D	D	D
	8,200pF (822)	X	X	D	D	D	D	D	D	D	D	C	C	C	D	D	K	K	D	D	D
	0.010μF (103)	X	X	D	D	D	D	D	D	D	D	C	C	C	D	D	K	K	D	D	D
	0.012μF (123)			D	D	D	D	D	D	D	D	C	C	C	D	D	K	K	D	D	D
	0.015μF (153)			D	D	D	D	D	D	D	D	C	C	C	D	D	K	K	D	D	D
	0.018μF (183)			D	D	D	D	D	D	D	D	C	C	C	D	D	K	K	D	D	D
	0.022μF (223)			D	D	D	D	D	D	D	G	G	C	C	D	D	K	K	D	D	D
	0.027μF (273)			D	D			D	D	D	G	G	C	C	G	G	K	K	D	D	D
	0.033μF (333)			D	D			G	D	D	G	G	C	C	G	G	K	K	D	D	D
	0.039μF (393)			D	D			G	D	D	G	G	C	C	G	G	K	K	D	D	D
	0.047μF (473)			D	D			G	D	D	G	G	D	D	G	G	K	K	D	D	D
	0.056μF (563)			D	D			G	D	D	G	G	D	D	G	G	K	K	D	D	K
	0.068μF (683)			D	D			G	D	D			G	D	K	K	K	K	D	D	K
0.082μF (823)			D				G	D	D			G	D	K	K			D	D	K	
0.10μF (104)			D				G	D	D			G	D	K	K			D	D	K	
0.12μF (124)												G	D					D	D	M	
0.15μF (154)												M	D					K	K	M	
0.18μF (184)												M	D					K	K	M	
0.22μF (224)												M	D					K	K	M	
0.27μF (274)												M	D					K	K		
0.33μF (334)												M	D					K	K		
0.39μF (394)												M	D					K	K		
0.47μF (474)												M	D					K	K		
0.56μF (564)																		M	M		
0.68μF (684)																		M	M		
0.84μF (844)																		M	M		
1.0μF (105)																		M	M		

1. The letter in cell is expressed the symbol of product thickness.

7-3 Y5V Dielectric

DIELECTRIC		Y5V							
SIZE		0805		1206		1210		1812	
RATED VOLTAGE (VDC)		200	250	200	250	200	250	200	250
Capacitance	0.010 $\mu$ F (103)	B	B	B	B	C	C	D	D
	0.015 $\mu$ F (153)	B	B	B	B	C	C	D	D
	0.022 $\mu$ F (223)	B	B	B	B	C	C	D	D
	0.033 $\mu$ F (333)	B	B	B	B	C	C	D	D
	0.047 $\mu$ F (473)	B	B	B	B	C	C	D	D
	0.068 $\mu$ F (683)	B	B	B	B	C	C	D	D
	0.10 $\mu$ F (104)			B	B	C	C	D	D
	0.15 $\mu$ F (154)			C	C	C	C	D	D
	0.22 $\mu$ F (224)							D	D
	0.33 $\mu$ F (334)							D	D
	0.47 $\mu$ F (474)							D	D
	0.68 $\mu$ F (684)							D	D
1.0 $\mu$ F (105)									

1. The letter in cell is expressed the symbol of product thickness.

### 8. CAPACITANCE RANGE (HIGH VOLTAGE - 1kV to 3kV)

#### 8-1 NP0 Dielectric

DIELECTRIC		NP0														
SIZE	0805	1206			1210			1808				1812				
RATED VOLTAGE	1000	1000	1500	2000	1000	1500	2000	1000	1500	2000	3000	1000	1500	2000	3000	
Capacitance	0.5pF (0R5)	D														
	1.0pF (1R0)	D														
	1.2pF (1R2)	D														
	1.5pF (1R5)	D	B	B	B											
	1.8pF (1R8)	D	B	B	B											
	2.0pF (2R0)	D	B	B	B				D	D	D	D				
	2.2pF (2R2)	D	B	B	B				D	D	D	D				
	2.7pF (2R7)	D	B	B	B				D	D	D	D				
	3.3pF (3R3)	D	B	B	B				D	D	D	D				
	3.9pF (3R9)	D	B	B	B				D	D	D	D				
	4.7pF (4R7)	D	B	B	B				D	D	D	D				
	5.6pF (5R6)	D	B	B	B				D	D	D	D				
	6.8pF (6R8)	D	B	B	B				D	D	D	D				
	8.2pF (8R2)	D	B	B	B				D	D	D	D				
	10pF (100)	D	B	B	B	C	C	C	D	D	D	D	D	D	D	D
	12pF (120)	D	B	B	B	C	C	C	D	D	D	D	D	D	D	D
	15pF (150)	D	B	B	B	C	C	C	D	D	D	D	D	D	D	D
	18pF (180)	D	B	B	B	C	C	C	D	D	D	D	D	D	D	D
	22pF (220)	D	B	B	B	C	C	C	D	D	D	D	D	D	D	D
	27pF (270)	D	B	B	B	C	C	C	D	D	D	D	D	D	D	D
	33pF (330)	D	B	C	C	C	C	C	D	D	D	D	D	D	D	D
	39pF (390)	D	B	C	C	C	C	C	D	D	D	D	D	D	D	D
	47pF (470)	D	C	C	C	C	C	C	D	D	D	D	D	D	D	D
	56pF (560)	D	C	D	D	C	D	D	D	D	D	D	D	D	D	D
	68pF (680)	D	C	D	D	C	D	D	D	D	D	D	D	D	D	D
	82pF (820)	D	D	D	D	C	D	D	D	D	D	D	D	D	D	D
	100pF (101)	D	D	D	D	D	D	D	D	D	K	K	D	D	D	D
	120pF (121)	D	D	G	G	D	D	D	D	D	K	K	D	D	D	D
	150pF (151)	D	D	G	G	D	G	G	D	K	K	K	D	D	D	D
	180pF (181)	D	G	G	G	D	G	G	D	K	K	K	D	D	K	K
220pF (221)	D	G	G	G	G	G	G	D	K	K	K	D	D	K	K	
270pF (271)	D	G	P	P	G	K	K	K	K	K	K	D	K	K	K	
330pF (331)	D	G	P	P	G	K	K	K	K	K	K	D	K	K	K	
390pF (391)	D	G	P	P	G	M	M	K	K	K		D	K	K	K	
470pF (471)		G			G	M	M	K	K	K		K	K	K	K	
560pF (561)		G			G			K	K	K		K	K	K		
680pF (681)		G			G			K	K	K		K	K	K		
820pF (821)		G			G			K				K	K	K		
1,000pF (102)		G			G			K				K	K	K		
1,200pF (122)												K				
1,500pF (152)												K				

1. The letter in cell is expressed the symbol of product thickness.

**8-2 X7R Dielectric**

DIELECTRIC		X7R																		
SIZE		0805				1206				1210			1808				1812			
RATED VOLTAGE		1000	1000	1500	2000	2500	1000	1500	2000	1000	1500	2000	3000	1000	1500	2000	3000			
Capacitance	100pF (101)	B	D	D	D	D	D	D	D											
	120pF (121)	B	D	D	D	D	D	D	D											
	150pF (151)	B	D	D	D	D	D	D	D	D	D	D	D							
	180pF (181)	B	D	D	D	D	D	D	D	D	D	D	D							
	220pF (221)	B	D	D	D	D	D	D	D	D	D	D	D							
	270pF (271)	B	D	D	D	D	D	D	D	D	D	D	D	D	D	D	D	K		
	330pF (331)	B	D	D	D	D	D	D	D	D	D	D	K	D	D	D	K			
	390pF (391)	B	D	D	D	D	D	D	D	D	D	D	K	D	D	D	K			
	470pF (471)	B	D	D	D	D	D	D	D	D	D	D	K	D	D	D	K			
	560pF (561)	B	D	D	D	D	D	D	D	D	D	D	K	D	D	D	K			
	680pF (681)	B	D	D	D	D	D	D	D	D	D	D	K	D	D	D	K			
	820pF (821)	B	D	G	G	D	D	D	D	D	D	D	K	D	D	D	K			
	1,000pF (102)	B	D	G	G	D	D	D	D	D	K	K	K	D	D	D	K			
	1,200pF (122)	B	D	G	G		D	M	M	D	K	K	K	D	D	D	K			
	1,500pF (152)	D	D	G	G		D	M	M	D	K	K	K	D	D	D	K			
	1,800pF (182)	D	D	G	G		D	M	M	D	K	K	K	D	G	G	M			
	2,200pF (222)	D	D	G	G		D	M	M	D	K	K		D	G	G	M			
	2,700pF (272)		D	G	G		D	M	M	D	K	K		D	G	G	M			
	3,300pF (332)		D	G	G		D	M	M	D	K	K		D	K	K	M			
	3,900pF (392)		D	G			G	M	M	D	K	K		D	K	K				
	4,700pF (472)		D	G			G	M	M	D	K	K		D	K	K				
	5,600pF (562)		D	G			G			K	K	K		D						
	6,800pF (682)		D	G			G			K				D						
	8,200pF (822)		D				G			K				D						
0.010μF (103)		D				G			K				D							
0.012μF (123)		G				G			K				K							
0.015μF (153)		G				G			K				K							
0.018μF (183)						G			K				M							
0.022μF (223)						G			K				M							
0.033μF (333)									K				M							
0.047μF (473)									K				M							
0.10μF (104)													M							

1. The letter in cell is expressed the symbol of product thickness.

**9. PACKAGING DIMENSION AND QUANTITY**

Size	Thickness/Symbol (mm)		Paper tape		Plastic tape	
			7" reel	13" reel	7" reel	13" reel
0603	0.80±0.07	S	4k	15k	-	-
	0.80 +0.15/-0.10	X	4k	15k		
0805	0.60±0.10	A	4k	15k	-	-
	0.80±0.10	B	4k	15k	-	-
	1.25±0.10	D	-	-	3k	10k
1206	0.80±0.10	B	4k	15k	-	-
	0.95±0.10	C	-	-	3k	10k
	1.25±0.10	D	-	-	3k	10k
	1.60±0.20	G	-	-	2k	10k
1210	0.95±0.10	C	-	-	3k	10k
	1.25±0.10	D	-	-	3k	10k
	1.60±0.20	G	-	-	2k	-
	2.00±0.20	K	-	-	1k	6k
	2.50±0.30	M	-	-	1k	6k
1808	1.25±0.10	D	-	-	2k	10k
	2.00±0.20	K	-	-	1k	6k
1812	1.25±0.10	D	-	-	1k	5k
	1.60±0.20	G	-	-	1k	-
	2.00±0.20	K	-	-	1k	-
	2.50±0.30	M	-	-	0.5k	3k

Unit: pieces



## 10. RELIABILITY TEST CONDITIONS AND REQUIREMENTS

No.	Item	Test Condition	Requirements																
1.	Visual and Mechanical	---	No remarkable defect. Dimensions to conform to individual specification sheet.																
2.	Capacitance	Class I: (NP0)	Shall not exceed the limits given in the detailed spec.																
3.	Q/ D.F. (Dissipation Factor)	Cap≤1000pF, 1.0±0.2Vrms, 1MHz±10% Cap>1000pF, 1.0±0.2Vrms, 1KHz±10% Class II: (X7R, Y5V) 1.0±0.2Vrms, 1kHz±10%	NP0: Cap≥30pF, Q≥1000; Cap<30pF, Q≥400+20C X7R: ≤2.5% Y5V: ≤5.0%																
4.	Dielectric Strength	* To apply voltage: 200V~300V ≥2 times VDC 500V~999V ≥1.5 times VDC 1000V~3000V ≥1.2 times VDC * Cut-off, set at 10mA * TEST= 15 sec. * RAMP=0	No evidence of damage or flash over during test.																
5.	Insulation Resistance	Rated voltage: 200~630V	To apply rated voltage (500V max.) for 60 sec. ≥10GΩ or RxC≥100Ω-F whichever is smaller																
		Rated voltage: ≥630V	To apply 500V for 60 sec. ≥10GΩ																
6.	Temperature Coefficient	With no electrical load. <table border="1"> <thead> <tr> <th>T.C.</th> <th>Operating Temp</th> </tr> </thead> <tbody> <tr> <td>NP0</td> <td>-55~125°C at 25°C</td> </tr> <tr> <td>X7R</td> <td>-55~125°C at 25°C</td> </tr> <tr> <td>Y5V</td> <td>-25~85°C at 20°C</td> </tr> </tbody> </table>	T.C.	Operating Temp	NP0	-55~125°C at 25°C	X7R	-55~125°C at 25°C	Y5V	-25~85°C at 20°C	<table border="1"> <thead> <tr> <th>T.C.</th> <th>Capacitance Change</th> </tr> </thead> <tbody> <tr> <td>NP0</td> <td>Within ±30ppm/°C</td> </tr> <tr> <td>X7R</td> <td>Within ±15%</td> </tr> <tr> <td>Y5V</td> <td>Within +30%/-80%</td> </tr> </tbody> </table>	T.C.	Capacitance Change	NP0	Within ±30ppm/°C	X7R	Within ±15%	Y5V	Within +30%/-80%
T.C.	Operating Temp																		
NP0	-55~125°C at 25°C																		
X7R	-55~125°C at 25°C																		
Y5V	-25~85°C at 20°C																		
T.C.	Capacitance Change																		
NP0	Within ±30ppm/°C																		
X7R	Within ±15%																		
Y5V	Within +30%/-80%																		
7.	Adhesive Strength of Termination	Pressurizing force : 5N (≤0603) and 10N (>0603) * Test time: 10±1 sec.	No remarkable damage or removal of the terminations.																
8.	Vibration Resistance	* Vibration frequency: 10~55 Hz/min. * Total amplitude: 1.5mm * Test time: 6 hrs. (Two hrs each in three mutually perpendicular directions.) * Measurement to be made after keeping at room temp. for 24±2 hrs.	* No remarkable damage. * Cap change and Q/D.F.: To meet initial spec.																
9.	Solderability	* Solder temperature: 235±5°C * Dipping time: 2±0.5 sec.	95% min. coverage of all metalized area.																
10.	Bending Test	* The middle part of substrate shall be pressurized by means of the pressurizing rod at a rate of about 1 mm per second until the deflection becomes 1 mm and then the pressure shall be maintained for 5±1 sec. * Measurement to be made after keeping at room temp. for 24±2 hrs.	* No remarkable damage. * Cap change : NP0: within ±5.0% or ±0.5pF whichever is larger. X7R: within ±12.5% Y5V: within ±30% (This capacitance change means the change of capacitance under specified flexure of substrate from the capacitance measured before the test.)																
11.	Resistance to Soldering Heat	* Solder temperature: 260±5°C * Dipping time: 10±1 sec * Preheating: 120 to 150°C for 1 minute before immerse the capacitor in a eutectic solder. * Before initial measurement (Class II only): Perform 150+0/-10°C for 1 hr and then set for 24±2 hrs at room temp. * Measurement to be made after keeping at room temp. for 24±2 hrs.	* No remarkable damage. * Cap change: NP0: within ±2.5% or ±0.25pF whichever is larger. X7R: within ±7.5% Y5V: within ±20% Q/D.F., I.R. and dielectric strength: To meet initial requirements. * 25% max. leaching on each edge.																

No.	Item	Test Condition	Requirements															
12.	Temperature Cycle	<p>Conduct the five cycles according to the temperatures and time.</p> <table border="1"> <thead> <tr> <th>Step</th> <th>Temp. (°C)</th> <th>Time (min.)</th> </tr> </thead> <tbody> <tr> <td>1</td> <td>Min. operating temp. +0/-3</td> <td>30±3</td> </tr> <tr> <td>2</td> <td>Room temp.</td> <td>2~3</td> </tr> <tr> <td>3</td> <td>Max. operating temp. +3/-0</td> <td>30±3</td> </tr> <tr> <td>4</td> <td>Room temp.</td> <td>2~3</td> </tr> </tbody> </table> <p>* Before initial measurement (Class II only): Perform 150+0/-10°C for 1 hr and then set for 24±2 hrs at room temp. * Measurement to be made after keeping at room temp. for 24±2 hrs.</p>	Step	Temp. (°C)	Time (min.)	1	Min. operating temp. +0/-3	30±3	2	Room temp.	2~3	3	Max. operating temp. +3/-0	30±3	4	Room temp.	2~3	<p>No remarkable damage.</p> <p>Cap change : NP0: within ±2.5% or ±0.25pF whichever is larger. X7R: within ±7.5% Y5V: within ±20% * Q/D.F., I.R. and dielectric strength: To meet initial requirements.</p>
Step	Temp. (°C)	Time (min.)																
1	Min. operating temp. +0/-3	30±3																
2	Room temp.	2~3																
3	Max. operating temp. +3/-0	30±3																
4	Room temp.	2~3																
13.	Humidity (Damp Heat) Steady State	<p>* Test temp.: 40±2°C * Humidity: 90~95% RH * Test time: 500+24/-0hrs. * Before initial measurement (Class II only): Perform 150+0/-10°C for 1 hr and then set for 24±2 hrs at room temp. * Measurement to be made after keeping at room temp. for 24±2 hrs.</p>	<p>* No remarkable damage. * Cap change: NP0: within ±5.0% or ±0.5pF whichever is larger. X7R: within ±12.5% Y5V: within ±30% * Q/D.F. value: NP0: Cap≥30pF, Q≥350; 10pF≤Cap&lt;30pF, Q≥275+2.5C Cap&lt;10pF; Q≥200+10C X7R: ≤3.0% Y5V: ≤7.5% * I.R.: ≥1GΩ or RxC≥50Ω-F whichever is smaller.</p>															
14.	Humidity (Damp Heat) Load	<p>* Test temp.: 40±2°C * Humidity: 90~95%RH * Test time: 500+24/-0 hrs. * To apply voltage : rated voltage (Max. 500V) * Before initial measurement (Class II only): To apply test voltage for 1hr at 40°C and then set for 24±2 hrs at room temp. * Measurement to be made after keeping at room temp. for 24±2 hrs.</p>	<p>* No remarkable damage. * Cap change: NP0: within ±7.5% or ±0.75pF whichever is larger. X7R: within ±12.5% Y5V: within ±30% * Q/D.F. value: NP0: Cap≥30pF, Q≥200; Cap&lt;30pF, Q≥100+10/3C X7R: ≤3.0% Y5V: ≤7.5% * I.R.: ≥500MΩ or RxC≥25Ω-F whichever is smaller.</p>															
15.	High Temperature Load (Endurance)	<p>* Test temp.: NP0, X7R: 125±3°C Y5V: 85±3°C * To apply voltage: (1) &lt;500V: 200% of rated voltage. (2) 500V: 150% of rated voltage. (3) ≥630V: 120% of rated voltage. (4) 1206/NP0 (3kV) ≥1.5pF: 100% of rated voltage. * Test time: 1000+24/-0 hrs. * Before initial measurement (Class II only): To apply test voltage for 1 hr at test temp. and then set for 24±2 hrs at room temp. * Measurement to be made after keeping at room temp. for 24±2 hrs</p>	<p>* No remarkable damage. * Cap change: NP0: within ±3.0% or ±0.3pF whichever is larger. X7R: within ±12.5% Y5V: within ±30% * Q/D.F. value: NP0: Cap≥30pF, Q≥350 10pF≤Cap&lt;30pF, Q≥275+2.5C Cap&lt;10pF, Q≥200+10C X7R: ≤3.0% Y5V: ≤7.5% * I.R.: ≥1GΩ or RxC≥50Ω-F whichever is smaller.</p>															

**APPENDIXES**

**■ Tape & reel dimensions**

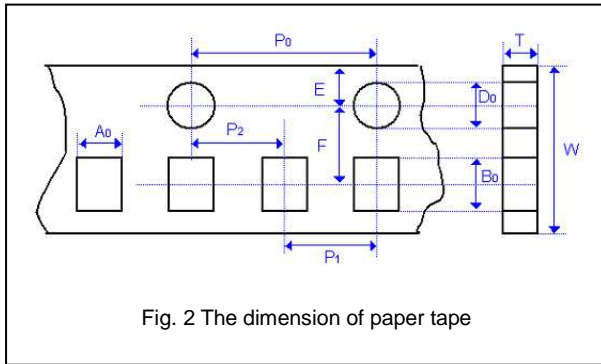

Fig. 2 The dimension of paper tape

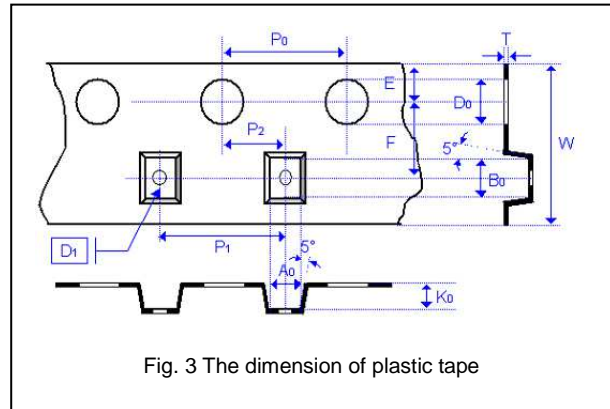

Fig. 3 The dimension of plastic tape

Size	0201	0402	0603	0805			1206			1210			1808	1812	
Thickness	L	N,E	S,H,X	A,H	B,T	D,I	B,T	C,J,D	G,P	T	C,D,G,K	M	D,F,G,K	D,F,G,K	M,U
<b>A<sub>0</sub></b>	0.39 +/-0.07	0.70 +/-0.2	1.05 +/-0.30	1.50 +/-0.20	1.50 +/-0.20	< 1.80	1.90 +/-0.50	< 2.00	< 2.30	< 3.05	< 3.05	< 3.20	< 2.50	< 3.90	< 3.90
<b>B<sub>0</sub></b>	0.69 +/-0.07	1.20 +/-0.2	1.80 +/-0.30	2.30 +/-0.20	2.30 +/-0.20	< 2.70	3.50 +/-0.50	< 3.70	< 4.00	< 3.80	< 3.80	< 3.95	< 5.30	< 5.30	< 5.30
<b>T</b>	≤ 0.50	≤ 0.80	≤ 1.20	≤ 1.15	≤ 1.30	0.23 +/-0.1	≤ 1.30	0.23 +/-0.1	0.23 +/-0.1	0.23 +/-0.1	0.23 +/-0.1	0.23 +/-0.1	0.25 +/-0.1	0.25 +/-0.1	0.25 +/-0.1
<b>K<sub>0</sub></b>	-	-	-	-	-	< 2.50	-	< 2.50	< 2.50	< 1.50	< 2.50	< 3.00	< 2.50	< 2.50	< 3.50
<b>W</b>	8.00 +/-0.10	8.00 +/-0.10	8.00 +/-0.10	8.00 +/-0.10	8.00 +/-0.10	8.00 +/-0.20	8.00 +/-0.10	8.00 +/-0.20	8.00 +/-0.20	8.00 +/-0.20	8.00 +/-0.20	8.00 +/-0.20	12.00 +/-0.20	12.00 +/-0.20	12.00 +/-0.20
<b>P<sub>0</sub></b>	4.00 +/-0.10	4.00 +/-0.10	4.00 +/-0.10	4.00 +/-0.10	4.00 +/-0.10	4.00 +/-0.10	4.00 +/-0.10	4.00 +/-0.10	4.00 +/-0.10	4.00 +/-0.10	4.00 +/-0.10	4.00 +/-0.10	4.00 +/-0.10	4.00 +/-0.10	4.00 +/-0.10
<b>10xP<sub>0</sub></b>	40.00 +/-0.10	40.00 +/-0.10	40.00 +/-0.20	40.00 +/-0.20	40.00 +/-0.20	40.00 +/-0.20	40.00 +/-0.20	40.00 +/-0.20	40.00 +/-0.20	40.00 +/-0.20	40.00 +/-0.20	40.00 +/-0.20	40.00 +/-0.20	40.00 +/-0.20	40.00 +/-0.20
<b>P<sub>1</sub></b>	2.00 +/-0.05	2.00 +/-0.05	4.00 +/-0.10	4.00 +/-0.10	4.00 +/-0.10	4.00 +/-0.10	4.00 +/-0.10	4.00 +/-0.10	4.00 +/-0.10	4.00 +/-0.10	4.00 +/-0.10	4.00 +/-0.10	4.00 +/-0.10	8.00 +/-0.10	8.00 +/-0.10
<b>P<sub>2</sub></b>	2.00 +/-0.05	2.00 +/-0.05	2.00 +/-0.05	2.00 +/-0.05	2.00 +/-0.05	2.00 +/-0.05	2.00 +/-0.05	2.00 +/-0.05	2.00 +/-0.05	2.00 +/-0.05	2.00 +/-0.05	2.00 +/-0.05	2.00 +/-0.10	2.00 +/-0.10	2.00 +/-0.10
<b>D<sub>0</sub></b>	1.55 +/-0.05	1.55 +/-0.05	1.55 +/-0.05	1.55 +/-0.05	1.55 +/-0.05	1.50 +0.1/-0	1.55 +/-0.05	1.50 +0.1/-0	1.50 +0.1/-0	1.50 +0.1/-0	1.50 +0.1/-0	1.50 +0.1/-0	1.50 +0.1/-0	1.50 +0.1/-0	1.50 +0.1/-0
<b>D<sub>1</sub></b>	-	-	-	-	-	1.00 +/-0.10	-	1.00 +/-0.10	1.00 +/-0.10	1.00 +/-0.10	1.00 +/-0.10	1.00 +/-0.10	1.50 +/-0.10	1.50 +/-0.10	1.50 +/-0.10
<b>E</b>	1.75 +/-0.05	1.75 +/-0.05	1.75 +/-0.05	1.75 +/-0.05	1.75 +/-0.05	1.75 +/-0.10	1.75 +/-0.05	1.75 +/-0.10	1.75 +/-0.10	1.75 +/-0.10	1.75 +/-0.10	1.75 +/-0.10	1.75 +/-0.10	1.75 +/-0.10	1.75 +/-0.10
<b>F</b>	3.50 +/-0.05	3.50 +/-0.05	3.50 +/-0.05	3.50 +/-0.05	3.50 +/-0.05	3.50 +/-0.05	3.50 +/-0.05	3.50 +/-0.05	3.50 +/-0.05	3.50 +/-0.05	3.50 +/-0.05	3.50 +/-0.05	5.50 +/-0.10	5.50 +/-0.10	5.50 +/-0.10

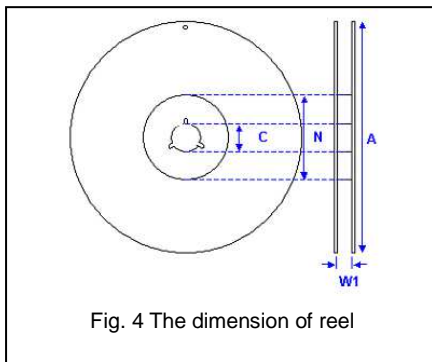
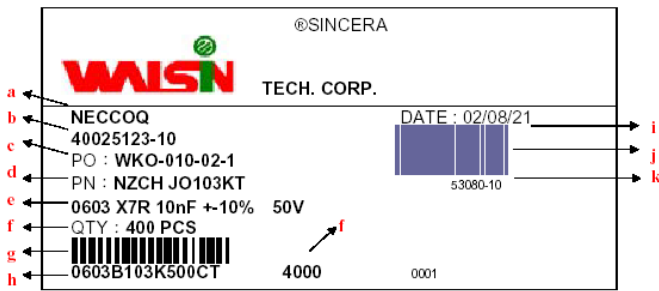

Fig. 4 The dimension of reel

Size	0603, 0805, 1206, 1210			1808, 1812
Reel size	7"	10"	13"	7"
<b>C</b>	13.0+0.5/-0.2	13.0+0.5/-0.2	13.0+0.5/-0.2	13.0+0.5/-0.2
<b>W<sub>1</sub></b>	8.4+1.5/-0	8.4+1.5/-0	8.4+1.5/-0	12.4+2.0/-0
<b>A</b>	178.0±1.00	250.0±1.0	330.0±1.0	178.0±1.00
<b>N</b>	60.0+1/-0	100.0±1.0	100±1.0	60.5±1.0

▣ Description of customer label



- a. Customer name
- b. WTC order series and item number
- c. Customer P/O
- d. Customer P/N
- e. Description of product
- f. Quantity
- g. Bar code including quantity & WTC P/N or customer
- h. WTC P/N
- i. Shipping date
- j. Order bar code including series and item numbers
- k. Serial number of label

▣ Constructions

No.	Name	NPO	NPO, X7R, Y5V
①	Ceramic material	BaTiO <sub>3</sub> based	
②	Inner electrode	AgPd alloy	Ni
③	Termination	Inner layer	Ag
④		Middle layer	Ni
⑤		Outer layer	Sn

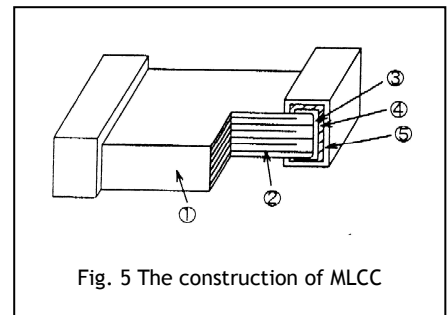

Fig. 5 The construction of MLCC

\* Partial NPO items are with Ag/Ni/Sn terminations, please ref to product range of NPO dielectric for detail.

▣ Storage and handling conditions

- (1) To store products at 5 to 40°C ambient temperature and 20 to 70% related humidity conditions.
- (2) The product is recommended to be used within one year after shipment. Check solderability in case of shelf life extension is needed.

Cautions:

- a. The corrosive gas reacts on the terminal electrodes of capacitors, and results in the poor solderability. Do not store the capacitors in the ambience of corrosive gas (e.g., hydrogen sulfide, sulfur dioxide, chlorine, ammonia gas etc.)
- b. In corrosive atmosphere, solderability might be degraded, and silver migration might occur to cause low reliability.
- c. Due to the dewing by rapid humidity change, or the photochemical change of the terminal electrode by direct sunlight, the solderability and electrical performance may deteriorate. Do not store capacitors under direct sunlight or dewing condition. To store products on the shelf and avoid exposure to moisture.

☐ Recommended soldering conditions

The lead-free termination MLCCs are not only to be used on SMT against lead-free solder paste, but also suitable against lead-containing solder paste. If the optimized solder joint is requested, increasing soldering time, temperature and concentration of N<sub>2</sub> within oven are recommended.

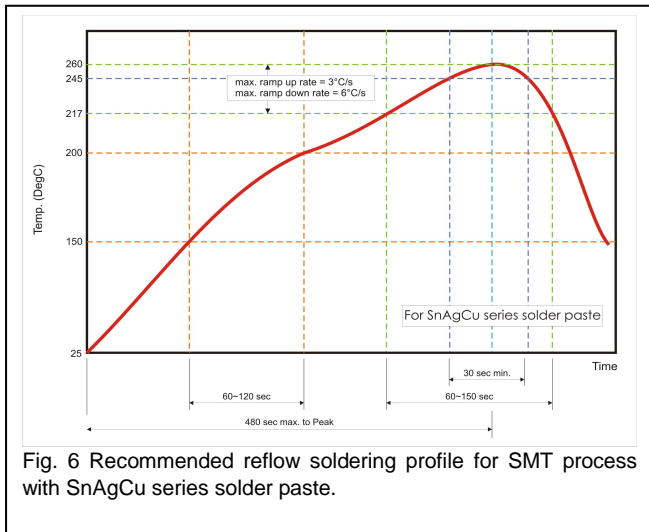

Fig. 6 Recommended reflow soldering profile for SMT process with SnAgCu series solder paste.

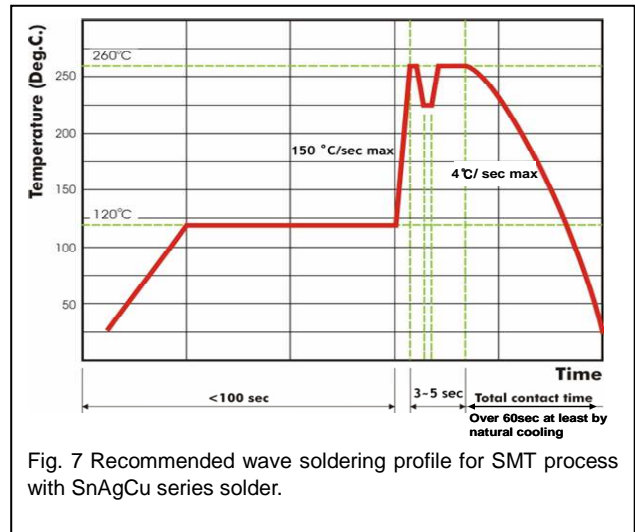

Fig. 7 Recommended wave soldering profile for SMT process with SnAgCu series solder.

## X-ON Electronics

Largest Supplier of Electrical and Electronic Components

*Click to view similar products for [Multilayer Ceramic Capacitors MLCC - SMD/SMT](#) category:*

*Click to view products by [Walsin](#) manufacturer:*

Other Similar products are found below :

[M39014/01-1467](#) [M39014/02-1218V](#) [M39014/02-1225V](#) [M39014/02-1262V](#) [M39014/02-1301](#) [M39014/22-0631](#) [1210J5000102JCT](#)  
[1210J2K00102KXT](#) [1210J5000103KXT](#) [1210J5000223KXT](#) [D55342E07B379BR-TR](#) [D55342E07B523DR-T/R](#) [1812J1K00103KXT](#)  
[1812J1K00473KXT](#) [1812J2K00680JCT](#) [1812J4K00102MXT](#) [1812J5000102JCT](#) [1812J5000103JCT](#) [1812J5000682JCT](#) [NIN-FB391JTRF](#)  
[NIN-FC2R7JTRF](#) [NPIS27H102MTRF](#) [C1206C101J1GAC](#) [C1608C0G1E472JT000N](#) [C2012C0G2A472J](#) [2220J2K00101JCT](#)  
[KHC201E225M76N0T00](#) [1812J1K00222JCT](#) [1812J2K00102KXT](#) [1812J2K00222KXT](#) [1812J2K00472KXT](#) [2-1622820-7-CUT-TAPE](#)  
[2220J3K00102KXT](#) [2225J2500824KXT](#) [CCR07CG103KM](#) [CGA2B2C0G1H010C](#) [CGA2B2C0G1H040C](#) [CGA2B2C0G1H050C](#)  
[CGA2B2C0G1H060D](#) [CGA2B2C0G1H070D](#) [CGA2B2C0G1H151J](#) [CGA2B2C0G1H1R5C](#) [CGA2B2C0G1H2R2C](#) [CGA2B2C0G1H3R3C](#)  
[CGA2B2C0G1H680J](#) [CGA2B2C0G1H6R8D](#) [CGA2B2X8R1H221K](#) [CGA2B2X8R1H472K](#) [CGA3E1X7R1C474K](#)  
[CGA3E2C0G1H561JT0Y0N](#)