



製品仕様書 SPECIFICATIONS

客戶名稱：

Customer：

客戶料號：

Part Number：

產品名稱：

碳素皮膜固定電阻器

Product：

Carbon Film Fixed Resistor

大益料號：

碳素皮膜固定電阻器系列

Part Number：

RD シリーズ / RD series

RoHS 対応品
RoHS Compliant product
HF 対応品
Halogen Free product

TAI ELECTRONIC CO.,LTD. (TAIWAN)
ADD: NO. 133 NAN-KANN RD. SEC. 1,
TAIWAN R.O.C.
TEL: +886-3-322-1988~9
FAX: +886-3-352-4879
Website: <http://www.taiohm.com.tw>

DONGGUAN TAI ELECTRONIC CO.,LTD. (CHINA)
ADD: LIHENG INDUSTRIAL ESTATE QINGXI
TOWN, DONGGUAN CITY, GUANGDONG
PROVINCE, CHINA
TEL: +86-769-8731-3175~7
FAX: +86-769-8731-3179
Website: <http://www.taiohm.com.tw>

TAI-OHM ELECTRONICS (M) SDN. BHD
ADD: PLOT 564-D, LORONG PERUSAHAAN
BARU 2, KAWASAN PERUSAHAAN PERAI,
13600 PERAI, SEBERANG PERAI,
SPT, PULAU PINANG, MALAYSIA.
TEL: +604-390-0480
FAX: +604-390-1481
Website: <http://www.taiohm.com.my>

TA-I TECHNOLOGY (SU ZHOU) CO.,LTD. (CHINA)
ADD: SOUTH ZHAN-HONG BRIDGE, LU-XIANG
NORTH ROAD, SONG-LING TOWN, WU-JIANG
CITY, JIANG-SU, CHINA
TEL: +86-512-6345-7879
FAX: +86-512-6345-7869
Website: <http://www.tai.com.tw>

P.T.TAI ELECTRONIC INDONESIA
ADD: BLOK T1 E, F, Jl. Jababeka IV Cikarang
Industrial Estate Bekasi 17530, Indonesia
TEL: +62-21-8983-0123
FAX: +62-21-8983-0703
Website: pttai@cbn.net.id

TA-I TECHNOLOGY (DongGuan) CO.,LTD.
(CHINA)
ADD: 11 TEAM, SHIEM-MA CHUN, CHING-PING
TOWN, DONGGUAN CITY, GUANGTON
PROVINCE R.O.C.
TEL: +86-769-8339-4790
FAX: +86-769-8339-4794
Website: <http://www.tai.com.tw>

TA-I TECHNOLOGY CO.,LTD. (TAIWAN)
ADD: NO. 26, LANE 470, SEC 2. NANSHAN RD.
LUJHU TOWNSHIP, TAOYUAN, TAIWAN,
R.O.C.
TEL: +886-3-324-6169
FAX: +886-3-324-6167
Website: <http://www.tai.com.tw>

客戶承認章
Approval By

承認

檢印

担当者

承認

檢印

担当者

張華隆

李明

徐傑瓊

TAI ELECTRONIC CO.,LTD.

2018/5/22

表單編號: QR-031

| Document No. | Document Name | | Edition |
|---------------|---------------|----------------------------|---------|
| TAI-RD-5006-A | RD series | Carbon Film Fixed Resistor | 2018-1 |

Carbon Film Fixed Resistor

Table of Contents

| | | |
|---------------------------------------|-------|----|
| 1. Specifications | ----- | 3 |
| 2. Performance | ----- | 5 |
| 3. Construction & Dimension | ----- | 7 |
| 4. Color Coding Drawing | ----- | 12 |
| 5. Axial Taping Specification | ----- | 13 |
| 6. Dimension of Axial Operation | ----- | 14 |
| 7. Axial Taping Box | ----- | 15 |
| 8. Marking of Packing Box | ----- | 15 |
| 9. Recommend having the tin condition | ----- | 16 |
| 10. Notice | ----- | 16 |
| 11. QC Diagram | ----- | 17 |
| 12. Part Number Table | ----- | 18 |

| | | | |
|---------------|---------------|----------------------------|---------|
| Document No. | Document Name | | Edition |
| TAI-RD-5006-A | RD series | Carbon Film Fixed Resistor | 2018-1 |

1 – Specifications –

1.1 – Scope –

This specification applies to the Carbon Film Fixed Resistors made by TAI ELECTRONIC CO., LTD

For resistance values below 10 ohms, it shall only be applied to Nickel Metal Film.

1.2 – Type designation –

Types are designated as follows.

| RD | 25 | T2 | 102 | J | (B) |
|---------------------------------|--|---|--|----------------------|------------|
| Type | Power Rating | Packaging Forming | Nominal Value of Resistance | Resistance Tolerance | Dimension |
| RD: Carbon Film Fixed Resistors | 16:1/6W, 1/8W 25:1/4W 50:1/2W 1W:1W 2W:2W 3W:3W 25S:1/4WS 50S:1/2WS | T2: 26m/m Taping T5: 52m/m Taping T6: 63m/m Taping T7: 73m/m Taping Bulk: P: P-Type F: F-Type FK: FK-Type FFK: FFK-Type FKK: FKK-Type H: H-Type HB: HB-Type HK: HK-Type | 100: 10Ω 101: 100Ω 102: 1KΩ 103: 10KΩ 104: 100KΩ 105: 1MΩ | G: 2% J: 5% | TAI's Code |

1.3 – Rating –

The ratings of resistors are described in the following Sections. The rating of each type of resistor is indicated in each associated Tables.

-Table.1 Rating Table-

| Items | Contents | | | | | | | | | |
|-------------------------------------|---------------------------|------|------|------|-------|-------|-----|-----|-----|--|
| Type | 1/8W | 1/4 | 1/2W | 1W | 1/4WS | 1/2WS | 1WS | 2WS | 3WS | |
| Rated Wattage | 1/8W | 1/4W | 1/2W | 1W | 1/4W | 1/2W | 1W | 2W | 3W | |
| Max. Operational Voltage | 250 | 300 | 350 | 500 | 250 | 300 | 300 | 350 | 350 | |
| Max. Overload Voltage | 400 | 600 | 700 | 1000 | 400 | 500 | 500 | 600 | 600 | |
| Max. Intermittence Overload Voltage | 400 | 750 | 1000 | 1000 | 500 | 600 | 600 | 600 | 600 | |
| Dielectric Withstanding Voltage | 300 | 500 | 700 | 1000 | 250 | 300 | 500 | 500 | 500 | |
| Rated Ambient Temperature | 70°C | | | | | | | | | |
| Operating Temperature Range | -55°C to 155°C | | | | | | | | | |
| Resistance Tolerance | Class J ±5% / Class G ±2% | | | | | | | | | |
| Resistance Value Range | 1Ω ~ 3.3MΩ | | | | | | | | | |

| | | | |
|---------------|---------------|----------------------------|---------|
| Document No. | Document Name | | Edition |
| TAI-RD-5006-A | RD series | Carbon Film Fixed Resistor | 2018-1 |

1.3.1 –Rated Wattage–

The rated wattage is the maximum continuous power to be applied at operating temperature range. However, for the temperature above 70°C, the rated wattage shall be derated per Fig.1.

Rated Wattage (%)

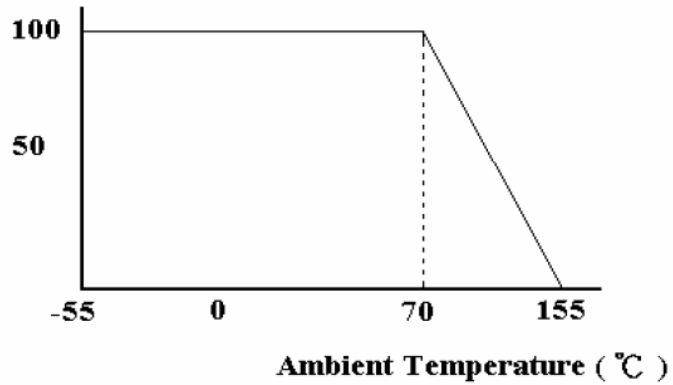

-Fig.1 Derating curve-

1.3.2 –Rated Voltage–

The rated voltage is denoted as D.C. or rms A.C. voltage which is calculated according to the following formula. However, it is limited to the maximum applicable voltage.

$$E = \sqrt{P \times R}$$

E: Rated voltage (V)
 P: Rated wattage (W)
 R: Rated Resistance (Ω)

1.3.3 –Rated Resistance–

- (1). The rated resistance is specified in accordance with the E24 Series Numbers as shown in Table2.
- (2). The manufacturing resistance range is shown in each associated rating Tables.
- (3). The resistance tolerance is shown in each associated rating Tables.

-Table.2 E-24 Series resistance Value-

| Effective Numerical Values of Rated Resistance | | | | | | | | | | | |
|--|-----|-----|-----|-----|-----|-----|-----|-----|-----|-----|-----|
| 1.0 | 1.1 | 1.2 | 1.3 | 1.5 | 1.6 | 1.8 | 2.0 | 2.2 | 2.4 | 2.7 | 3.0 |
| 3.3 | 3.6 | 3.9 | 4.3 | 4.7 | 5.1 | 5.6 | 6.2 | 6.8 | 7.5 | 8.2 | 9.1 |

| | | | |
|---------------|---------------|----------------------------|---------|
| Document No. | Document Name | | Edition |
| TAI-RD-5006-A | RD series | Carbon Film Fixed Resistor | 2018-1 |

2 — Performance —

| No. | Item | | Spec. Level | Test Method (JIS-C-5202) | | | | | | |
|------------------|---|------|---|--|------|------|------------------|-------------------|-----------------|----------------|
| 1 | Resistance Value | | Within the tolerance | Par. 5.1 Applicable voltage Category A. | | | | | | |
| 2 | Temperature characteristics of resistance | | See the rating Tables | Par. 5.2 measured at the room temperature and + 100°C . Designations of T.C.R. are shown in Par. 5.2.2(2) (a). | | | | | | |
| 3 | Short time overload | | Tolerable change within $\pm(1\% + 0.05\Omega)$. No visual damage & marking be legible. | Par. 5.5 Condition A (2.5 times, 5sec). Maximum overload voltages are shown in the rating Tables. | | | | | | |
| 4 | Dielectric withstanding voltage | | Flash over, burning or insulation damages should not be observed. | Par. 5.7 Condition A (V-blocks). Test voltage is shown in the rating Tables. Load period: 5sec. | | | | | | |
| 5 | Pulse | | Tolerable change within $\pm(1\% + 0.05\Omega)$ & marking be legible | Par. 5.8 Applicable only to 100 Ω or higher. The pulse voltage applied is 4 times of the rated voltage. The maximum pulse voltage is shown in the rating Tables. Pulse frequency : 10,000 \pm 200 cycles. | | | | | | |
| 6 | Terminal Strength | Pull | Lead broken or terminal loosen should not be observed. | Par. 6.1.2(1) Not applicable to formed leads. Force applied for 16 to 5 sec. | | | | | | |
| | | Bend | | Par.6.1.2(4) Not applicable to formed leads. | | | | | | |
| 7 | Resistance to soldering heat | | Tolerable change within $\pm(1\% + 0.05\Omega)$. No mechanical damage & no notable damage be observed in appearance | Par. 6.4 Select from the following conditions: Normally condition A is used. <table style="margin-left: 40px;"> <tr> <td>Temp</td> <td>Time</td> </tr> <tr> <td>A 350\pm10°C</td> <td>3.5\pm0.5 Sec</td> </tr> <tr> <td>B 260\pm5°C</td> <td>10\pm1 Sec</td> </tr> </table> Dipping be continuously applied from one lead to others. Cooling after dipping should be 3Hrs. | Temp | Time | A 350 \pm 10°C | 3.5 \pm 0.5 Sec | B 260 \pm 5°C | 10 \pm 1 Sec |
| Temp | Time | | | | | | | | | |
| A 350 \pm 10°C | 3.5 \pm 0.5 Sec | | | | | | | | | |
| B 260 \pm 5°C | 10 \pm 1 Sec | | | | | | | | | |
| 8 | Solderability | | 4/5 area of circular surface be wet with new solder. | Par. 6.5 Solder temperature: 245 \pm 5°C . Dip period: 3 \pm 0.5 Sec. Dipping is applied for one terminal at a time. Pre-treatment should not be made. Examined visually. | | | | | | |

| | | | |
|---------------|---------------|----------------------------|---------|
| Document No. | Document Name | | Edition |
| TAI-RD-5006-A | RD series | Carbon Film Fixed Resistor | 2018-1 |

| No. | Item | Spec. Level | Test Method (JIS-C-5202) | | | | | | | | |
|------------------------|---|--|--|------------|-------|-----------------------|---------------------------|------------------------|----------------------------|------------------------|----------------------------|
| 9 | Temperature cycling | $\Delta R \leq \pm(1\% + 0.05\Omega)$. No mechanical damage be observed & marking be legible. | Par. 7.4 Temperature: $-55\pm 3^{\circ}\text{C}$ to $155\pm 2^{\circ}\text{C}$ Cycles: 5 times. | | | | | | | | |
| 10 | Humidity load life | No remarkable abnormalities on appearance. Marking shall be Legible Variation of resistance($5\% + 0.1\Omega$) | Temperature: $85\pm 2^{\circ}\text{C}$ Relative humidity: 85% to 90% Duration: 500 +24 -0 h | | | | | | | | |
| 11 | Load life | No remarkable abnormalities on appearance. Marking shall be Legible Variation of resistance($5\% + 0.1\Omega$) | Par. 7.10 Ambient temp: $70\pm 2^{\circ}\text{C}$. Testing period: 1,000 + 48 Hrs. 1,000 - 0 Hrs. | | | | | | | | |
| 12 | Solvent test | No notable change in appearance & marking be legible. | JIS-C-5202 does not specify this item. Solvent used: Trichloride ethane (1:1:1) or Freon TE Ultra sonic used: 28KHz, 200W. Dip time period: 1 Min. | | | | | | | | |
| 13 | Terminal Strength (A) Tensile Strength (B) Bending Strength (C) Tensional Strength | $\pm(1\% + 0.05\Omega)$ No cap missing and terminal wire breakage shall occur $\pm(1\% + 0.05\Omega)$ No terminal wire loosening and breakage shall occur $\pm(1\% + 0.05\Omega)$ No terminal wire loosening and breakage shall occur | Tensile strength 2.5KG is maintained for 30 seconds Bending strength 500g load 90°reciprocation twice Tensional strength 360° 5 times | | | | | | | | |
| 14 | Packaging Drop Down Experiment | Packaging box and isolation coating resistor didn't broken. Resistance value variation $\pm (3\% + 0.05\Omega)$. | From height 30 cm, falling the goods and repeat 3 times | | | | | | | | |
| 15 | Resistance value change per year | The resistor in the room temperature for 1 year. | Resistance value variation $< \pm 1\%$ | | | | | | | | |
| 16 | Noise test | Noise shall measured by Resistor noise test set model 315c by Quan-Tech Div. Max Vr shall be 30dB | <table border="1"> <thead> <tr> <th>Resistance</th> <th>Noise</th> </tr> </thead> <tbody> <tr> <td>$\leq 10\text{K ohm}$</td> <td>5dB(1.8$\mu\text{V/V}$)</td> </tr> <tr> <td>$\leq 100\text{K ohm}$</td> <td>10dB(3.2$\mu\text{V/V}$)</td> </tr> <tr> <td>$\leq 1.0\text{M ohm}$</td> <td>15dB(5.6$\mu\text{V/V}$)</td> </tr> </tbody> </table> | Resistance | Noise | $\leq 10\text{K ohm}$ | 5dB(1.8 $\mu\text{V/V}$) | $\leq 100\text{K ohm}$ | 10dB(3.2 $\mu\text{V/V}$) | $\leq 1.0\text{M ohm}$ | 15dB(5.6 $\mu\text{V/V}$) |
| Resistance | Noise | | | | | | | | | | |
| $\leq 10\text{K ohm}$ | 5dB(1.8 $\mu\text{V/V}$) | | | | | | | | | | |
| $\leq 100\text{K ohm}$ | 10dB(3.2 $\mu\text{V/V}$) | | | | | | | | | | |
| $\leq 1.0\text{M ohm}$ | 15dB(5.6 $\mu\text{V/V}$) | | | | | | | | | | |

| | | | |
|---------------|---------------|----------------------------|---------|
| Document No. | Document Name | | Edition |
| TAI-RD-5006-A | RD series | Carbon Film Fixed Resistor | 2018-1 |

| No | Item | Spec. Level | Test Method (JIS-C-5202) |
|----|-----------------------------------|--|---|
| 17 | High temperature storage test | No remarkable abnormalities on appearance. Marking shall be Legible Variation of resistance(5% + 0.1Ω) | In the 155℃ for 1000 hours |
| 18 | Low temperature storage test | No remarkable abnormalities on appearance. Marking shall be Legible Variation of resistance(5% + 0.1Ω) | In the -55℃ for 1000 hours |
| 19 | Temperature humidity storage test | No remarkable abnormalities on appearance. Marking shall be Legible Variation of resistance(5% + 0.1Ω) | In the chamber having temp. 60℃ and relative humidity 90% for 1000 hours |
| 20 | Vibration test | $\Delta R \leq \pm(1\% + 0.05\Omega)$. No mechanical damage be observed & marking be legible | Apply 1.5mm amplitude vibration to three directions perpendicular to each other 2 hours each, total 6 hours. Vibrating frequency is 10Hz-55Hz-10Hz cycle in 1 minute sweeping and repeat cycle. |

3 — Construction, Dimensions —

3.1 — Construction —

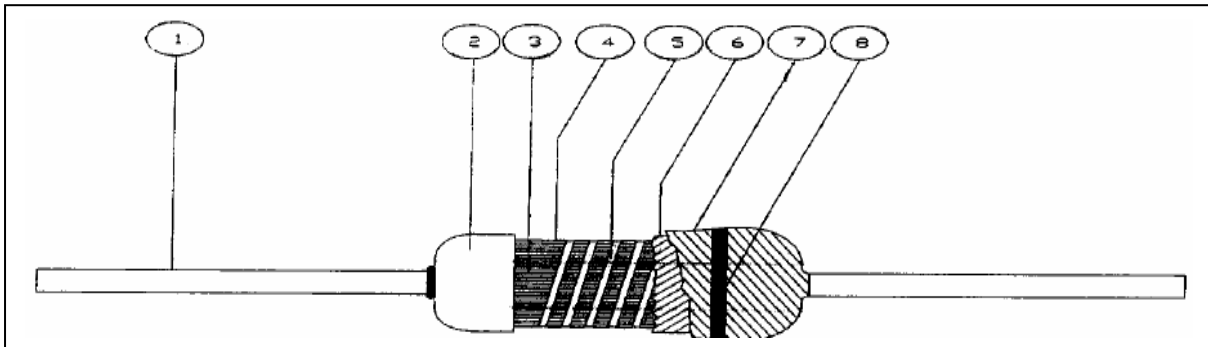

| NO. | Name | Material | Remark |
|-----|------------------------|---------------------------|----------------|
| 1 | Lead wire | Solder plated copper wire | Pb-free |
| 2 | Cap | Iron/Tin | Tin plating |
| 3 | Ceramic core | Aluminum base | |
| 4 | Conductive film | Carbon, Nickel for 10 | |
| 5 | Helical cutting groove | | |
| 6 | Medium coat Phenomic | Phenolic | Moisture-proof |
| 7 | Insulation coat | Epoxy | insulation |
| 8 | Color code | Epoxy | |

| | | | |
|---------------|---------------|----------------------------|---------|
| Document No. | Document Name | | Edition |
| TAI-RD-5006-A | RD series | Carbon Film Fixed Resistor | 2018-1 |

3.2 –Dimension– (P-Type)

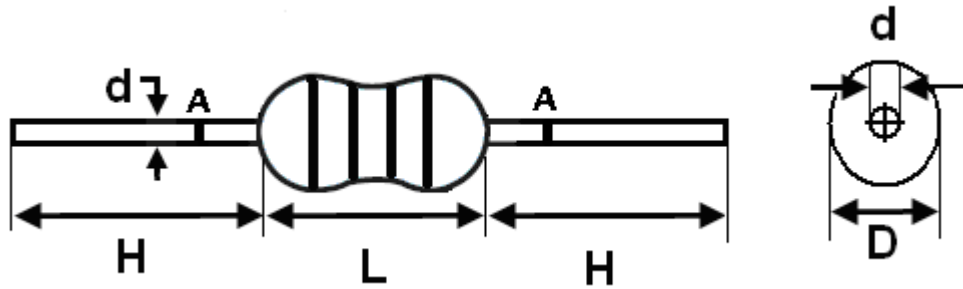

| P- TYPE | | Dimension (mm) | | | | |
|---------------|----------|----------------|---------|-------|-----|-----------|
| | | L (Max) | D (Max) | d±0.1 | H±3 | A (阻值測量點) |
| RD 1/6W(1/8W) | RD 1/4WS | 4.7 | 2.5 | 0.43 | 27 | 5.5 |
| RD 1/4W | RD 1/2WS | 7.2 | 3.5 | 0.52 | 27 | 5.0 |
| RD 1/2W | RD 1WS | 10.5 | 4.0 | 0.56 | 26 | 3.0 |
| RD 1W | RD 2WS | 12.5 | 5.0 | 0.73 | 30 | 4.0 |
| RD 2W | RD 3WS | 16.5 | 5.5 | 0.73 | 30 | 8.0 |
| RD 3W | RD 5WS | 19.5 | 6.5 | 0.73 | 30 | 7.0 |

–Dimension– (F-Type)

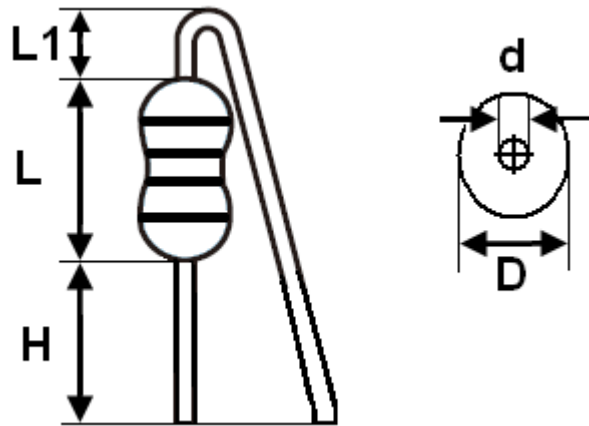

| F TYPE | | Dimension (mm) | | | | |
|--------|-------|----------------|----------|---------|-------|-------|
| | | L (Max) | L1 (Max) | D (Max) | d±0.1 | H±0.5 |
| RD1/2W | RD1WS | 10.5 | 3.0 | 4.0 | 0.56 | 4.0 |
| RD1W | RD2WS | 12.5 | 3.5 | 5.0 | 0.73 | 4.0 |
| RD2W | RD WS | 16.5 | 3.5 | 5.5 | 0.73 | 4.0 |
| RD3W | RD5WS | 19.5 | 3.5 | 6.5 | 0.73 | 4.0 |

| | | | |
|---------------|---------------|----------------------------|---------|
| Document No. | Document Name | | Edition |
| TAI-RD-5006-A | RD series | Carbon Film Fixed Resistor | 2018-1 |

—Dimension— (FK-Type)

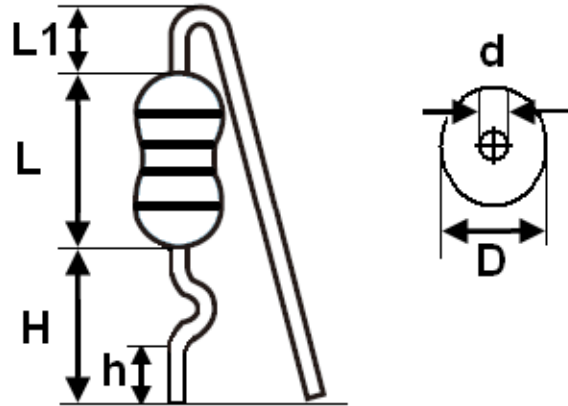

| FK TYPE | | Dimension (mm) | | | | | |
|---------|--------|----------------|----------|-------|---------|-------|-------|
| | | L (Max) | L1 (Max) | H±0.5 | D (Max) | d±0.1 | h±0.5 |
| RD 1/2W | RD 1WS | 10.5 | 3.0 | 8.0 | 4.0 | 0.56 | 4.0 |
| RD 1W | RD 2WS | 12.5 | 3.5 | 8.0 | 5.0 | 0.73 | 4.0 |
| RD 2W | RD 3WS | 16.5 | 3.5 | 8.0 | 5.5 | 0.73 | 4.0 |
| RD 3W | RD 5WS | 19.5 | 3.5 | 8.0 | 6.5 | 0.73 | 4.0 |

—Dimension— (FFK-Type)

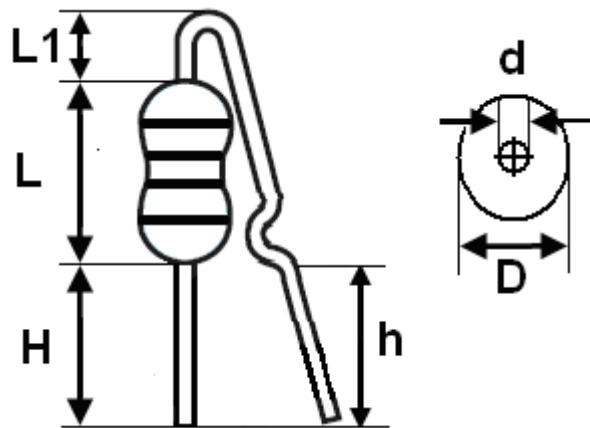

| FFK TYPE | | Dimension (mm) | | | | | |
|----------|-------|----------------|----------|-------|---------|-------|-------|
| | | L (Max) | L1 (Max) | H±0.5 | D (Max) | d±0.1 | h±0.5 |
| RD1/2W | RD1WS | 10.5 | 3.0 | 4.0 | 4.0 | 0.56 | 4.0 |
| RD1W | RD2WS | 12.5 | 3.5 | 4.0 | 5.0 | 0.73 | 4.0 |
| RD2W | RD3WS | 16.5 | 3.5 | 4.0 | 5.5 | 0.73 | 4.0 |
| RD3W | RD5WS | 19.5 | 3.5 | 4.0 | 6.5 | 0.73 | 4.0 |

| | | | |
|---------------|---------------|----------------------------|---------|
| Document No. | Document Name | | Edition |
| TAI-RD-5006-A | RD series | Carbon Film Fixed Resistor | 2018-1 |

—Dimension— (FKK-Type)

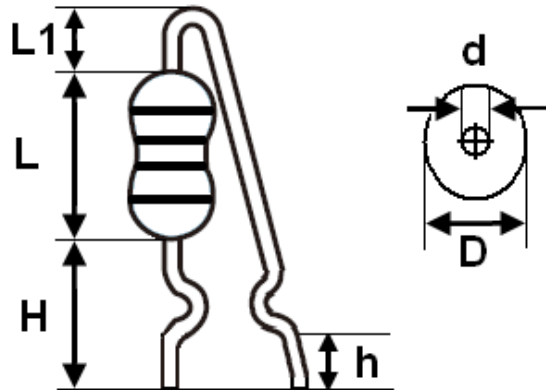

| FKK TYPE | | Dimension (mm) | | | | | |
|----------|-------|----------------|----------|---------|-------|-----|-------|
| | | L (Max) | L1 (Max) | D (Max) | d±0.1 | H±1 | h±0.5 |
| RD1/2W | RD1WS | 10.5 | 3.0 | 4.0 | 0.56 | 8.0 | 4.0 |
| RD1W | RD2WS | 12.5 | 3.5 | 5.0 | 0.73 | 8.0 | 4.0 |
| RD2W | RD3WS | 16.5 | 3.5 | 5.5 | 0.73 | 8.0 | 4.0 |
| RD3W | RD5WS | 19.5 | 3.5 | 6.5 | 0.73 | 8.0 | 4.0 |

—Dimension— (H-Type)

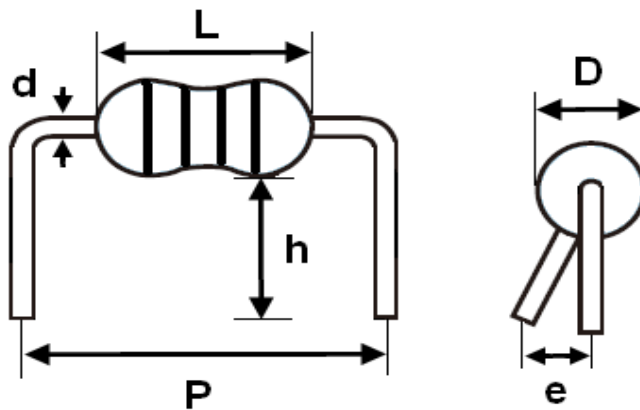

| H TYPE | | Dimension (mm) | | | | | |
|---------|--------|----------------|-------|---------|-------|--------|---------|
| | | P±1.5 | h±0.5 | e (Max) | d±0.1 | D(Max) | L (Max) |
| RD 1/2W | RD 1WS | 12.5 | 4.0 | 3.0 | 0.56 | 4.0 | 10.5 |
| RD 1W | RD 2WS | 15.0 | 4.0 | 3.0 | 0.73 | 5.0 | 12.5 |
| RD 2W | RD 3WS | 20.0 | 4.0 | 3.0 | 0.73 | 5.5 | 16.5 |
| RD3W | RD5WS | 23.0 | 8.5 | 3.0 | 0.73 | 6.5 | 19.5 |

| | | | |
|---------------|---------------|----------------------------|---------|
| Document No. | Document Name | | Edition |
| TAI-RD-5006-A | RD series | Carbon Film Fixed Resistor | 2018-1 |

—Dimension— (HB-Type)

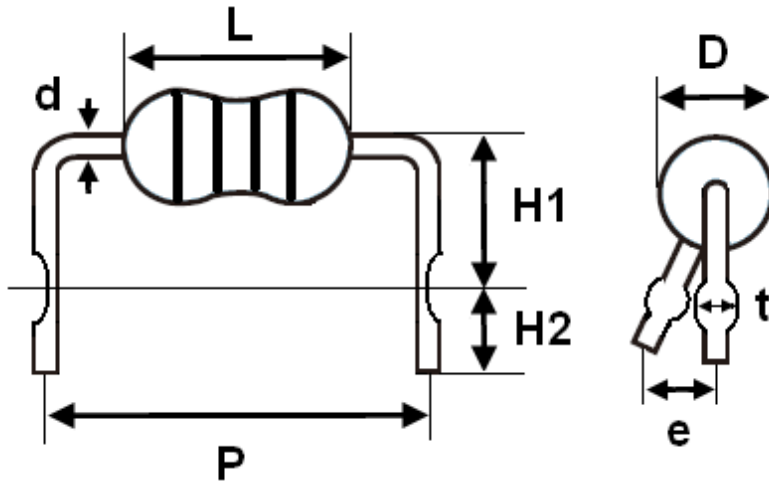

| HB TYPE | | Dimension (mm) | | | | | | | |
|---------|-------|----------------|--------------|--------------|---------|---------|-------------|---------|---------|
| | | P \pm 1 | H1 \pm 1.0 | H2 \pm 1.0 | t (Min) | e (Max) | d \pm 0.1 | D (Max) | L (Max) |
| RD1/2W | RD1WS | 12.5 | 10.0 | 5.0 | 1.2 | 3.0 | 0.56 | 4.0 | 10.5 |
| RD1W | RD2WS | 15.0 | 10.0 | 5.0 | 1.2 | 3.0 | 0.73 | 5.0 | 12.5 |
| RD2W | RD3WS | 20.0 | 10.0 | 5.0 | 1.2 | 3.0 | 0.73 | 5.5 | 16.5 |
| RD3W | RD5WS | 23.0 | 10.0 | 5.0 | 1.2 | 3.0 | 0.73 | 6.5 | 19.5 |

—Dimension— (HK-Type)

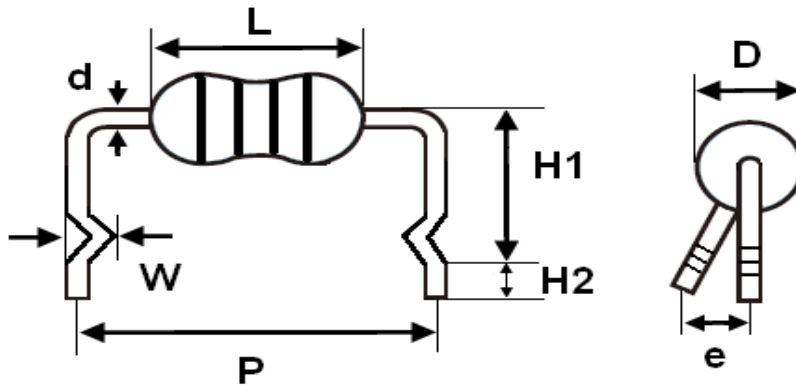

| HK TYPE | | Dimension (mm) | | | | | | | |
|---------|-------|----------------|--------------|--------------|---------|-------------|---------|---------|---------|
| | | P \pm 1.5 | H1 \pm 1.0 | H2 \pm 0.5 | W (Min) | d \pm 0.1 | e (Max) | D (Max) | L (Max) |
| RD1/2W | RD1WS | 12.5 | 8.5 | 4.0 | 1.0 | 0.56 | 3.0 | 4.0 | 10.5 |
| RD1W | RD2WS | 15.0 | 11.0 | 4.0 | 1.0 | 0.73 | 3.0 | 5.0 | 12.5 |
| RD2W | RD3WS | 20.0 | 11.0 | 4.0 | 1.0 | 0.73 | 3.0 | 5.5 | 16.5 |
| RD3W | RD5WS | 23.0 | 11.0 | 4.0 | 1.0 | 0.73 | 3.0 | 6.5 | 19.5 |

| | | | |
|---------------|---------------|----------------------------|---------|
| Document No. | Document Name | | Edition |
| TAI-RD-5006-A | RD series | Carbon Film Fixed Resistor | 2018-1 |

4 —Color Coding Drawing—

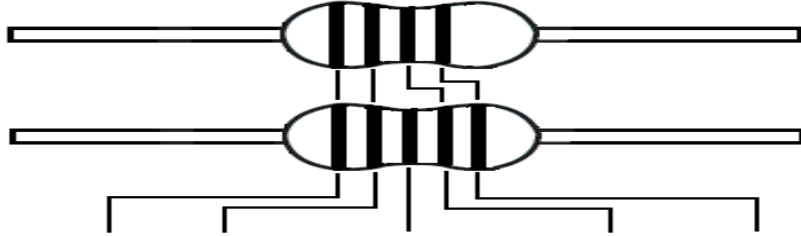

| Color | 1 st No. | 2 nd No. | 3 rd No. | Multipliers | Tolerance |
|--------|---------------------|---------------------|---------------------|-------------|-----------------|
| Black | 0 | 0 | 0 | 10^0 | |
| Brown | 1 | 1 | 1 | 10^1 | |
| Red | 2 | 2 | 2 | 10^2 | G ($\pm 2\%$) |
| Orange | 3 | 3 | 3 | 10^3 | |
| Yellow | 4 | 4 | 4 | 10^4 | |
| Green | 5 | 5 | 5 | 10^5 | |
| Blue | 6 | 6 | 6 | 10^6 | |
| Purple | 7 | 7 | 7 | | |
| Gray | 8 | 8 | 8 | | |
| White | 9 | 9 | 9 | | |
| Gold | | | | 10^{-1} | J ($\pm 5\%$) |
| Silver | | | | 10^{-2} | |

| Document No. | Document Name | | Edition |
|---------------|---------------|----------------------------|---------|
| TAI-RD-5006-A | RD series | Carbon Film Fixed Resistor | 2018-1 |

5 —Axial Taping Specification—

5.1 —Application—

This specification covers the axial taping operation for the coated insulated fixed carbon film resistors.

5.2 —Taping Operation—

Dimension of tape is shown in Fig. 4 and tapes are paper-based pressure adhesive tapes of the following requirements.

- (1). Width: $6.0 \pm 0.5 \text{ mm}$
- (2). Thickness: $0.15 \pm 0.05 \text{ mm}$
- (3). Adhesive power: 1700g/25mm wide Min.
- (4). Pull strength: 20.4g/25mm wide Min.
- (5). Elongation: 5% Max.

5.3 —Operation Requirements—

- (1). Color code orientation is not specified.
- (2). No drop out is permissible.
- (3). Adhesion length indicated as "t" shall be 3.2mm (min.) shown in Fig. 4.
- (4). Tape splicing is done by reinforcing tapes attached with both side as shown in Fig. 2.
- (5). Taping end indicated as "Z" shall have 2mm (max.) at the end of leading tape.

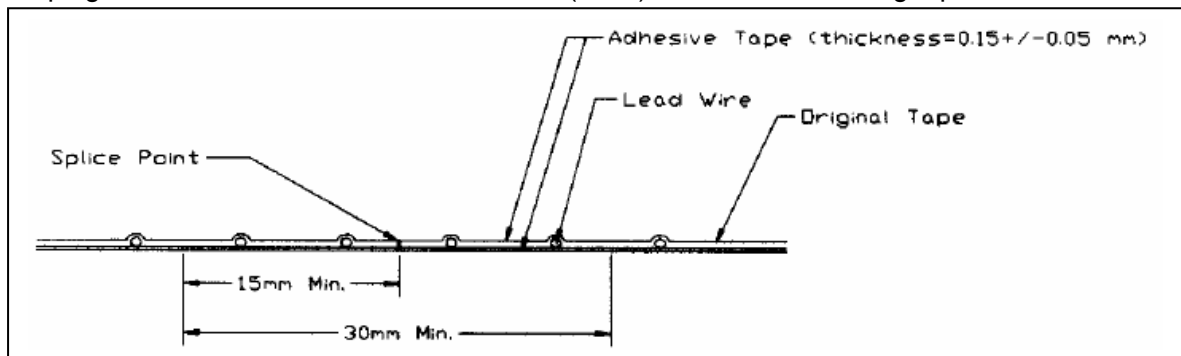

-FIG.2 Splicing of Tape Operation-

5.4 —Taped Packing—

- (1). Taped products are folded into the packing box as shown in Fig. 3.
- (2). Dimensions of boxes are shown in Fig.5 as well as Table 4.
- (3). Flap of the box is firmly taped.

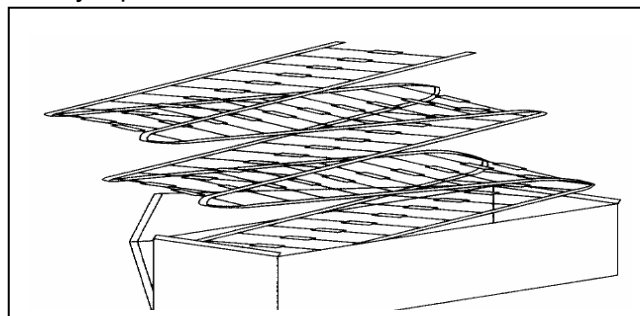

-FIG.3 Box Packing-

| | | | |
|---------------|---------------|----------------------------|---------|
| Document No. | Document Name | | Edition |
| TAI-RD-5006-A | RD series | Carbon Film Fixed Resistor | 2018-1 |

6 —Dimension of Axial Operation—

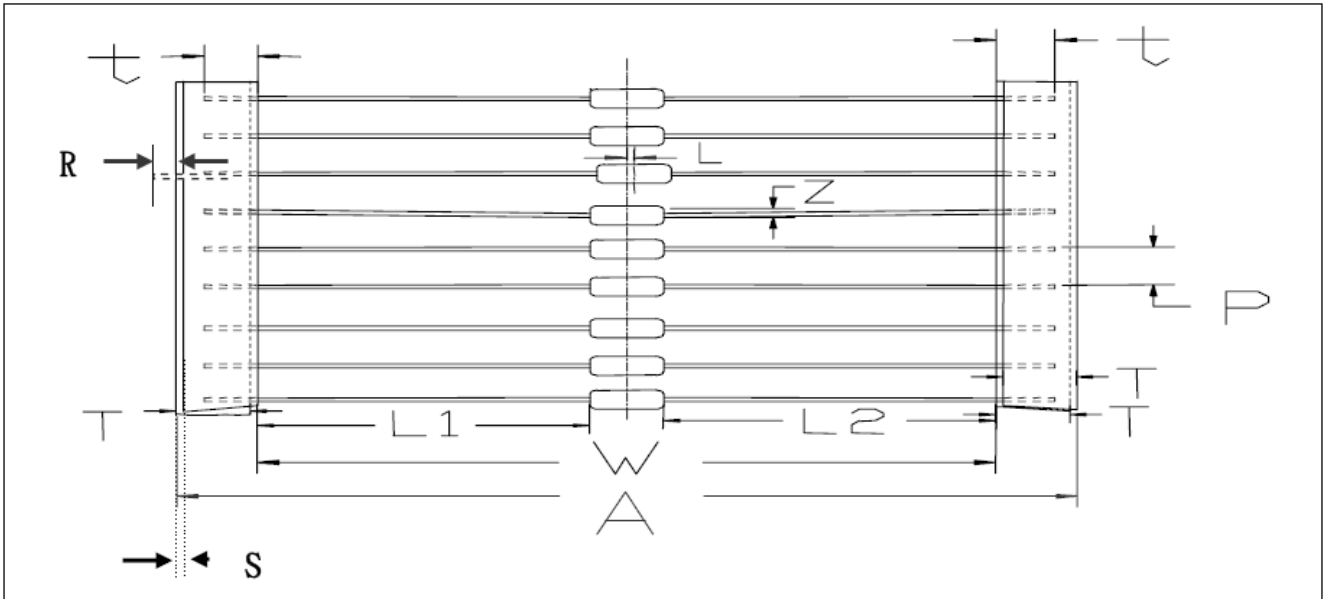

-FIG.4 Taping specifications-

-Table.3 Taping dimensions (Axial taping)-

| MARK | Dimension (mm) | | | | | | | |
|------|----------------|-----|-------|-------|------------|-------|-------|-------|
| | A±1 | W±1 | T±0.5 | t-Min | L1-L2(Max) | P±0.5 | Z-Max | L-Max |
| T26 | 38 | 26 | 6.0 | 2.0 | 1.0 | 5.0 | 1.0 | 1.0 |
| T52 | 64 | 52 | 6.0 | 2.0 | 1.0 | 5.0 | 1.0 | 1.0 |
| T63 | 75 | 63 | 6.2 | 2.0 | 1.0 | 5.0 | 1.0 | 1.0 |
| T73 | 86 | 73 | 6.2 | 2.0 | 1.0 | 10.0 | 1.0 | 1.0 |

(1) Integrated pitch tolerance is $\pm 2\text{mm}/20$ pitches (p) $\pm 1.6\text{mm}/20$ pitches (u).

(2) Absolute values of difference between 1 and 2.

(3) Adhesive length of lead wire.

(4) Tape snaking to tolerance is 0.5mm/300mm. -

| | | | |
|---------------|---------------|----------------------------|---------|
| Document No. | Document Name | | Edition |
| TAI-RD-5006-A | RD series | Carbon Film Fixed Resistor | 2018-1 |

7 –Axial Taping Box–

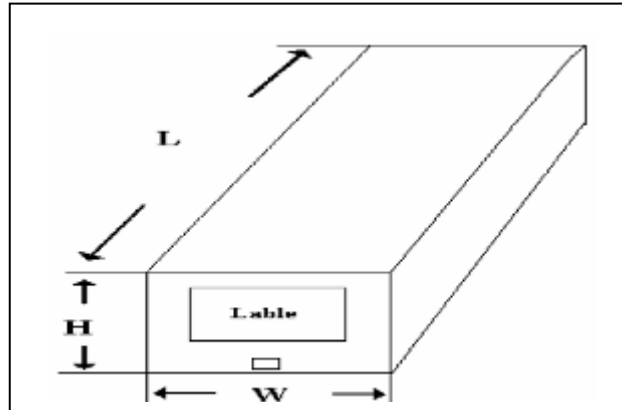

-FIG.5 Packing Box -

Table.4 Box Dimension-

| Type | | Quantity | MOQ (PCS) | H±5 | L±10 | W±5 |
|-----------------------|------------------------|-----------|-----------|-----|------|-----|
| RD 1/8W Taping (26mm) | RD 1/4WS Taping (26mm) | 5,000 pcs | 125,000 | 78 | 255 | 50 |
| RD 1/4W Taping (26mm) | RD 1/2WS Taping (26mm) | 5,000 pcs | 120,000 | 105 | 255 | 50 |
| RD 1/8W Taping (52mm) | RD 1/4WS Taping (52mm) | 5,000 pcs | 100,000 | 78 | 255 | 80 |
| RD 1/4W Taping (52mm) | RD 1/2WS Taping (52mm) | 5,000 pcs | 55,000 | 110 | 255 | 80 |
| RD 1/2W Taping (52mm) | RD 1WS Taping (52mm) | 2,000 pcs | 30,000 | 88 | 255 | 80 |
| RD 1W Taping (63mm) | RD 2WS Taping (63mm) | 1,000 pcs | 15,000 | 85 | 255 | 87 |
| RD 2W Taping (73mm) | RD 3WS Taping (73mm) | 1,000 pcs | 15,000 | 105 | 255 | 100 |

8 –Marking of Packing Box–

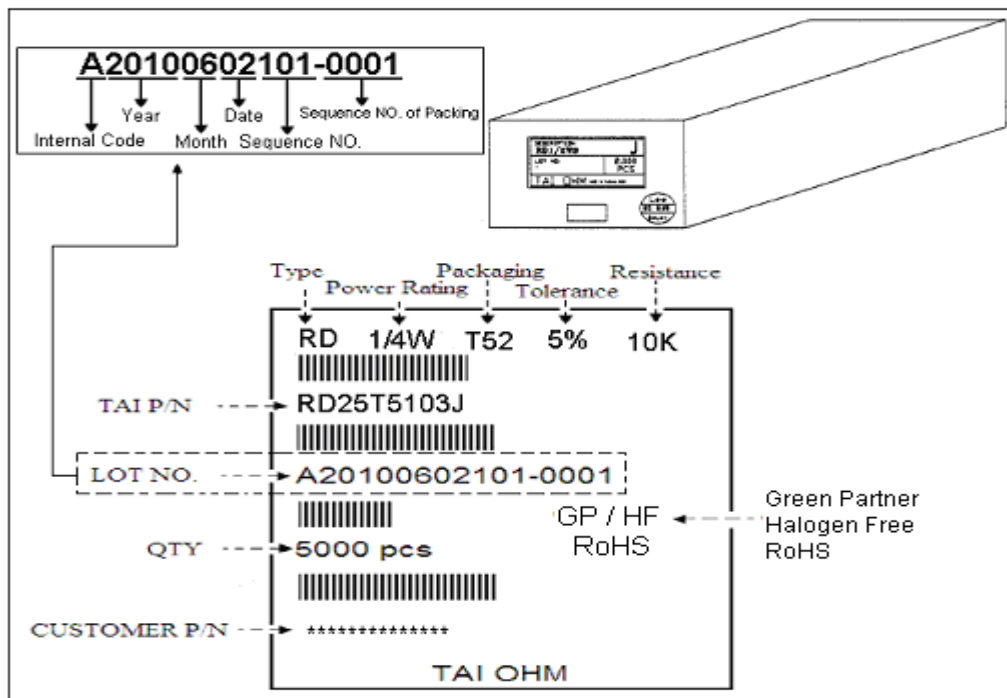

-FIG.6 Product label-

| Document No. | Document Name | | Edition |
|---------------|---------------|----------------------------|---------|
| TAI-RD-5006-A | RD series | Carbon Film Fixed Resistor | 2018-1 |

9. Recommend having the tin condition:

9.1. Weld the homework in crest

Whether preheat temperature. 110 °C max

Time of preheating: 60sec~120sec

The temperature of the homework / time: 260 °C / 10sec 1 second or 5sec two times

(Weld the curve and see and leave pursuing in relevant crests)

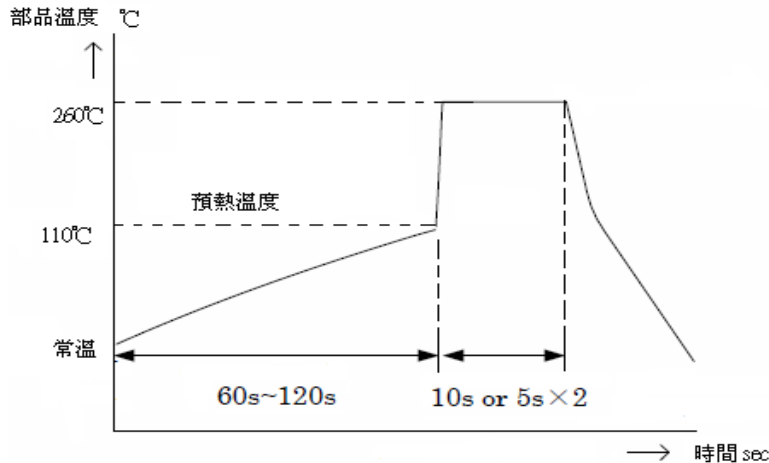

9.2. Soldering tin homework of the craft:

Soldering tin temperature: 350°C max

Soldering tin time: 3sec max

10 – Notice –

(1) Storage of resistors

Preferable storage conditions are follows: Temperature range is from 0°C to 30°C and the relative humidity (RH) is less than 65%. High temperature and humidity will change the resistance and cause poor solderability. Storage duration should be less than 2 year for the best performance.

(2) Loading conditions

Resistance change is highly dependent upon the loading conditions, such as temperature and load ratio. For long time stability, the derated conditions shall be applied. The resistor is flameproof, but care should be taken for safety. Safety resistors are available upon inquiry.

(3) Resistor insertion

Cares to be taken at the insertion time in order to prevent from the damages on coating and lead wires. Such a damages will cause the malfunctions. To bend the lead wires and keep an adequate radius is required to prevent the damages from welding points. Soldering heat applied should be minimize

(4) Moisture-proof, damp-proof, and sour-proof, to avoid the sun light directly in a long time.

(5) Open the resistor or box, the resistors cannot expose in the air for a long time. To avoid electrode and lead wire attached the substances or oxidize problem, cause the electrode and lead wire tin-plated NG.

(6) A pile of the resistors, the pressure cannot exceed 7 KG.

(7) When the goods used a adhesive tape or colors, it can use many colors excluding red and yellow color. (except color code).

(8) The components made by TAI have be widely applied in the filed of home appliance, automotive appliance, telecommunication, data...etc..

(9) Specification given herein may be changed at any time without prior notice please confirm TAI before you order or use.

11. – QC Diagram –

| Dept. | Q.A. | Date | 1998/10/05 | DIP Resistor QC Diagram | | Amendment | 2010/07/09 | NO. | WI-QC-01 | |
|------------|-----------------|------------------------|--|---|---|---|---|--|--------------------|-----------------|
| Version | 3 rd | | | | | | | Page | 1 OF 1 | |
| Flow | | Process | Equipment | Management Item | Related Document | Inspected Frequency | Control Method | Record Department | Exceptional Method | |
| Ex-Station | Station | | | | | | | | Ex-Station | Station |
| | | IQC | Measured Instrument | Dimension Appearance Character | IQC Standard Incoming Standard | 1 time/Lot | MSI/ASQC.Z1.4 I Level | Sampling Record Form Incoming Quality Exceptional Form | QC | Refuse Special |
| | | Cutting | Automatic Cutting Machine | Appearance Resistance | Cutting Standard Inspection Standard | 1 time/Lot | 10× Magnifying glass Check Machine | Subpoena | PL1 | Revise |
| | | Cutting Inspection | 10× Magnifying glass Check Machine | Appearance Resistance | Produce Control Standard Inspection Standard | 1 time/Lot | Appearance: MSI/ASQC.Z1.4 II Level Character: MSI/ASQC.Z1.4S-2 Level | Subpoena Over % Resistance Form Quality Exceptional Form | QC | Revise Stop |
| | | QC: Cutting Inspection | 10× Magnifying glass Check Machine Electronic Scale | Appearance Resistance | Produce Control Standard Inspection Standard | 1 time/Lot | Appearance: MSI/ASQC.Z1.4 II Level Character: MSI/ASQC.Z1.4S-2 Level | Subpoena Quality Examine in Cutting Section Form Over % Resistance Form Quality Exceptional Form | QC | Revise Stop |
| | | Welding | Automatic Welding Machine Caliber Tension Instrument | Appearance Dimension Tension Diameter Copper Length | Welding Standard Appearance Check Diagram | 1 time/Lot | Tension Instrument 10× Magnifying glass | Subpoena | PL1 | Revise |
| | | Welding Inspection | Tension Instrument Caliber 10× Magnifying glass | Appearance Dimension Tension Diameter Copper Length | Produce Control Standard Inspection Standard | 1 time/Lot | Appearance: MSI/ASQC.Z1.4 II Level Character: MSI/ASQC.Z1.4S-2 Level | Subpoena Quality Exceptional Form Test Summary | QC | Revise Stop |
| | | Coating | Coating Machine | Character Appearance Dimension Resistance | Coating Standard Coating % Standard | 100% Check | Voltage Form Check Machine Model Board Visual Inspection 2 Phenolic layers 4 Coating layers | Subpoena | PL1 | Revise |
| | | Coating Inspection | Voltage Form Check Machine Model Board | Appearance Dimension Resistance | Produce Control Standard Inspection Standard | 1 time/Lot | Appearance: MSI/ASQC.Z1.4 II Level | Subpoena Quality Exceptional Form Test Summary | QC | Revise Stop |
| | | Forming | Forming Machine | Appearance Dimension | Forming Standard | 1 time/Lot | Caliber Visual Inspection | Subpoena | PL1 | Revise |
| | | Forming Inspection | Caliber | Appearance Dimension | Inspection Standard Produce Control Standard | 1 time/Lot | Appearance: MSI/ASQC.Z1.4 II Level Character: MSI/ASQC.Z1.4S-2 Level | Subpoena Quality Exceptional Form Test Summary | QC | Revise Stop |
| | | Packaging | Model Board | Appearance | Packaging Standard | 100% Check | Visual Inspection | Subpoena | QC | Revise |
| | | Final Quality Control | Tension Instrument Caliber Model Board Check Machine | Appearance Dimension Quantity Resistance Tension | Inspection Standard Final Inspection for Goods Standard | Sampling of Character 100% Appearance Check | Appearance 100% Visual Inspection Character: MSI/ASQC.Z1.4S-3 Level | Subpoena Final Check Quality Exceptional Form | QC | Return Unusable |
| | | Outgoing Inspection | | Description Specification Quantity Part Number | Inspection Standard | 100% Check | Visual Inspection | Test Report Quality Exceptional Form Test Summary | QC | Return |

12. —Part Number Table —

| NO. | Customer P/N | TAI P/N | Remark |
|-----|--------------|---------|--------|
| 1 | | | |
| 2 | | | |
| 3 | | | |
| 4 | | | |
| 5 | | | |
| 6 | | | |
| 7 | | | |
| 8 | | | |
| 9 | | | |
| 10 | | | |
| 11 | | | |
| 12 | | | |
| 13 | | | |
| 14 | | | |
| 15 | | | |
| 16 | | | |
| 17 | | | |
| 18 | | | |
| 19 | | | |
| 20 | | | |
| 21 | | | |
| 22 | | | |
| 23 | | | |
| 24 | | | |
| 25 | | | |
| 26 | | | |
| 27 | | | |
| 28 | | | |
| 29 | | | |
| 30 | | | |

X-ON Electronics

Largest Supplier of Electrical and Electronic Components

Click to view similar products for [Carbon Composition Resistors](#) category:

Click to view products by [TA-I Tech](#) manufacturer:

Other Similar products are found below :

[IBT1/4102JLF](#) [OE5655](#) [OG5625](#) [OB1025](#) [OE1855](#) [OG2005](#) [IBT1/4100JLF](#) [OF-112JE](#) [OH6205](#) [RC0S2CA270RKE](#) [OF224KE](#)
[CF18JT910R](#) [RC20GF240J](#) [RC20GF561J](#) [RC07GF361J](#) [RC1/4435JB](#) [RC1/4135JB](#) [RC1/4201JTD](#) [RC1/2331KTD](#) [RC20GF470JTRLF](#)
[RC1/2155KTD](#) [RC1/4274KTD](#) [RC1/47R5JB](#) [RC1/4565JB](#) [RC1/4160JB](#) [RC1/2475KTB](#) [RC1/2471JTD](#) [RC1/2431JTD](#) [RC1/2334KB](#)
[RC1/2225KB](#) [RC1/2166KTD](#) [RC1/2103KTD](#) [RC1/2102JTD](#) [RC1/2434JB](#) [RC1/22R4JB](#) [RC1/2165JB](#) [RC07GF510JTR](#) [RCC025 2R7 J B](#)
[CFR0W4J0242A10](#) [CFR0W4J0391A50](#) [CFR0W4J0303A50](#) [CFR0W4J0433A50](#) [CFR03SJ0753AA0](#) [CFR03SJ0470AA0](#) [CF1/6W-20K±5%](#)
[T52](#) [CF1/4W-43±5% T52](#) [CFR01SJ0433A10](#) [RD50T5151J](#) [RD 1/8W 33K J T/B A1](#) [RD 2WS 3K6 J T/B A1](#)