

DESCRIPTION

The PT5126A is 1 Full-On Drive H-Bridge channel with two different packages. The driver features wide range operating from 2V to 24V and low power consumption by fast switching speed.

APPLICATIONS

- Toys
- Lens for DSLR
- Auto icemaker or dumper drive for refrigerator
- HV bi-direction DC Motor
- Intelligent electronic lock

FEATURES

- It is low consumption by BCD process adoption
- Two different small packages: HSOP8, SOP8
- Wide power-supply voltage range:
 - Control (VCC): 2.7V ~ 5.5V
 - Motor (VM): 2.0V ~ 24V
- High DC output current: Max.=2.8A
- Ultra low RDSON(TOP+BOT):
 - 0.51ΩTYP@25°C, 1A for HSOP8;
 - 0.64ΩTYP@25°C, 1A for SOP8
- Low current consumption when power-down: <math><0.05\mu\text{A}</math> @25°C
- PWM control, Max. input frequency: 200KHz.
- Operating temperature range: -40 ~ +85°C
- Charge-pump less
- Shoot-through current protection
- Built-in protection circuits
 - Under voltage lock out
- - Thermal shut down

BLOCK DIAGRAM

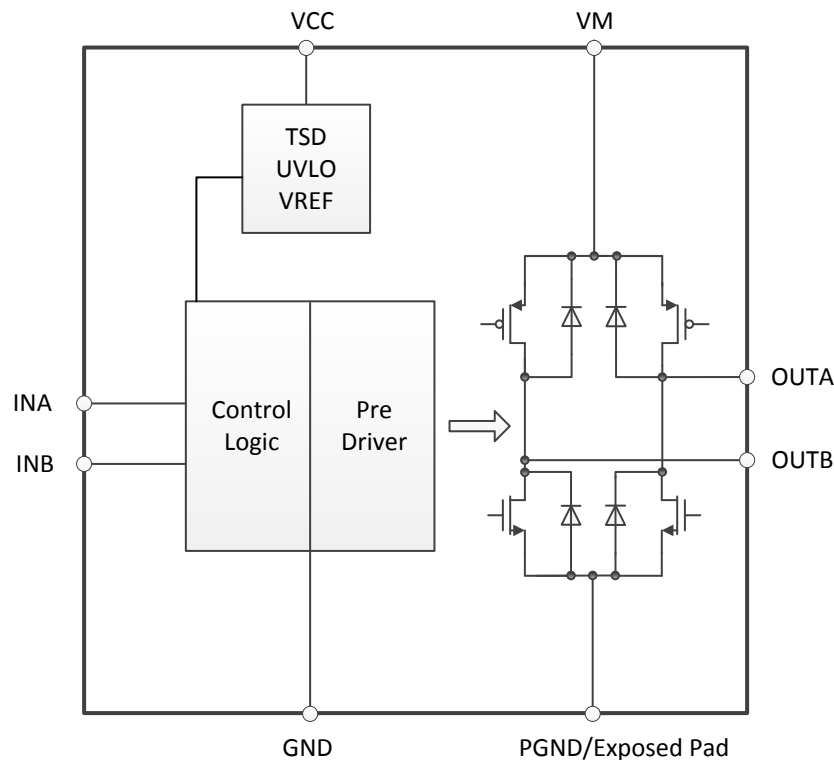

ORDER INFORMATION

Valid Part Number	Package Type	Top Code
PT5126A-S	8 pins, SOP	PT5126A-S
PT5126A-HS	8 pins, HSOP	PT5126A-HS

PIN CONFIGURATION

SOP8

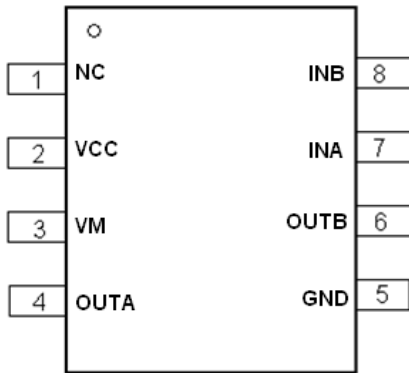

HSOP8

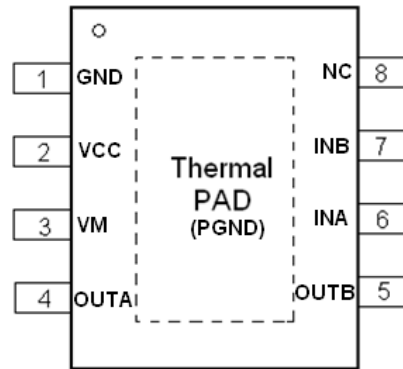

PIN DESCRIPTION

Pin Name	I/O	Description	Pin No.	
			SOP8	HSOP8
NC	-	NC pin	1	8
GND	GND	Ground	5	1
VCC	Power	Power supply for logic circuit	2	2
VM	Power	Power supply for driver	3	3
OUTA	O	H-Bridge output terminal A of the driver	4	4
OUTB	O	H-Bridge output terminal B of the driver	6	5
INA	I	Control input	7	6
INB	I	Control input	8	7
PGND	GND	Power MOS GND	-	Thermal PAD

IMPORTANT NOTICE

Princeton Technology Corporation (PTC) reserves the right to make corrections, modifications, enhancements, improvements, and other changes to its products and to discontinue any product without notice at any time.

PTC cannot assume responsibility for use of any circuitry other than circuitry entirely embodied in a PTC product. No circuit patent licenses are implied.

Princeton Technology Corp.
2F, 233-1, Baociao Road,
Sindian Dist., New Taipei City 23145, Taiwan
Tel: 886-2-66296288
Fax: 886-2-29174598
<http://www.princeton.com.tw>

X-ON Electronics

Largest Supplier of Electrical and Electronic Components

Click to view similar products for [Motor/Motion/Ignition Controllers & Drivers](#) category:

Click to view products by [Princeton](#) manufacturer:

Other Similar products are found below :

[LV8133JA-ZH](#) [LV8169MUTBG](#) [LV8774Q-AH](#) [LV8860PV-TLM-H](#) [MC33931EKR2](#) [MC34GD3000EP](#) [FSB50250UTD](#) [FSB50550TB2](#)
[FSBF15CH60BTH](#) [MP6507GR-P](#) [MP6508GF](#) [MSVCPM2-63-12](#) [MSVGW45-14-2](#) [MSVGW54-14-5](#) [NTE7043](#) [CAT3211MUTAG](#)
[LA6245P-CL-TLM-E](#) [LA6245P-TLM-E](#) [LA6565VR-TLM-E](#) [LB11650-E](#) [LB1694N-E](#) [LB1837M-TLM-E](#) [LB1845DAZ-XE](#) [LC898111AXB-](#)
[MH](#) [LC898300XA-MH](#) [SS30-TE-L-E](#) [STK531-345A-E](#) [STK581U3A0D-E](#) [STK58AUNP0D-E](#) [STK621-068C-E](#) [STK621-140C](#) [STK621-](#)
[728S-E](#) [STK625-728-E](#) [STK672-400B-E](#) [STK672-432AN-E](#) [STK672-432BN-E](#) [STK672-440AN-E](#) [STK672-442AN-E](#) [AMIS30621AUA](#)
[FSB50550ASE](#) [26700](#) [LV8161MUTAG](#) [LV8281VR-TLM-H](#) [LV8702V-TLM-H](#) [LV8734VZ-TLM-H](#) [LV8773Z-E](#) [LV8807QA-MH](#)
[MC33932EK](#) [MCP8024T-H/MP](#) [TND027MP-AZ](#)