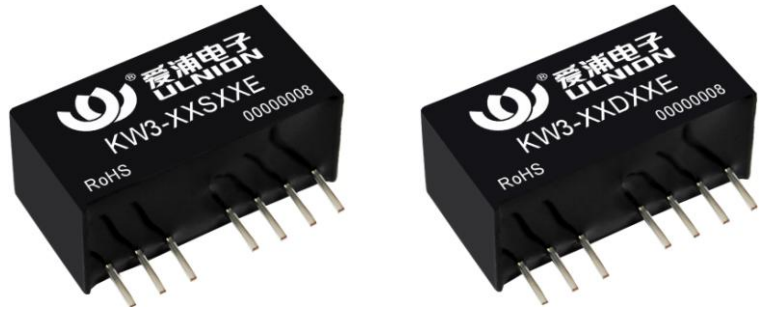
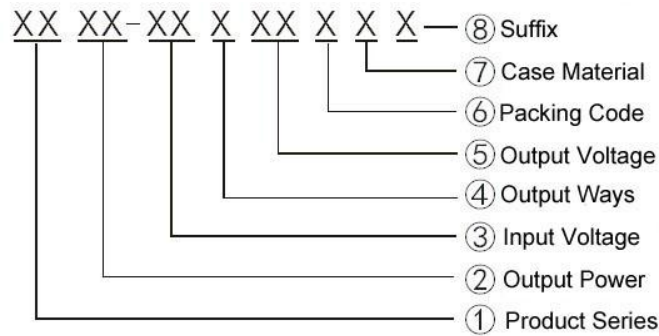

Typical Features

- ◆ Wide Input Voltage Range (2:1), Output Power 3W
- ◆ Conversion Efficiency up to 82%
- ◆ With remote control Switch-off function
- ◆ Continuous Short Circuit protection, Self-furbish
- ◆ No Overshooting when turn-on or off
- ◆ Isolation Voltage 1500VDC
- ◆ Operating Temperature: -40℃ ~ +85℃
- ◆ Plastic Case, meet UL94 V-0 standard

Product Named Method

Test Condition: Unless otherwise specified, data in the datasheet should be tested under the conditions of inputting nominal voltage, pure resistance rated load and Ta=25℃.

Input Specifications

Item	Test Condition	MIN	TYP	MAX	Unit
Max Input Surge Voltage (1Second)	4.5-9V Input	-0.7	-	16	VDC
	9-18V Input	-0.7	-	25	
	18-36V Input	-0.7	-	50	
	36-75V Input	-0.7	-	100	
Start-up Voltage	4.5-9V Input	3.5	4	4.5	VDC
	9-18V Input	4.5	8	9	
	18-36V Input	11	16	18	
	36-75V Input	24	33	36	
Stand-by Consumption	0.5W (MAX)				
Input Filter	Capacitor Filtering				

Output Specifications			
Positive Output Voltage Accuracy	Full voltage full load	+Vo	≤±2.0%
Negative Output Voltage Accuracy		-Vo	≤±3.0%
No Load Output Voltage Accuracy		Vo	Main circuit:≤±3.0%, Auxiliary circuit:≤±5.0%
Line Regulation	Nominal load, full voltage range	Vo	Main circuit:≤±0.2%, Auxiliary circuit:≤±0.5%
Load Regulation	10% ~ 100% nominal load	Vo	Main circuit≤±0.5%, Auxiliary circuit:≤±0.75%
Cross Regulation	Dual output, main circuit 50% load, auxiliary circuit 10% to 100% load		≤±5.0%
Ripple & Noise	Nominal load, nominal voltage		≤100mVp-p (20MHz bandwidth)
Temperature Coefficient	100% full load		±0.03%/°C
Output Short Circuit Protection	Continuous, Self-recovery		
Dynamic Response	25% nominal load step change	Δ Vo/Δ t	≤±5.0%/0.5ms(Typ.)

Note: 1.un-balancing loads of dual output:±5%;

2. Ripple & Noise Tested by twisted-pair method, for details please check Design and Application Circuit.

General Specifications		
Switching Frequency	Typical	450KHz
Operating Temperature	Refer to Temperature Derating Curve	-40°C ~ +85°C
Storage Temperature		-55°C ~ +125°C
Soldering Temperature	Waver soldering	260±4°C, timing 5-10S
	Manual soldering	360±8°C, timing 4-7S
Max Case Temperature	Within Temperature Derating Curve	+105°C
Relative Humidity	No condensing	5%~95%
Case Material		Black flame-retardant heat-resistant Plastic(UL94 V-0)
Product Weight		4.37g(Typ.)
Isolation Voltage	Input to Output	1500Vdc ≤ 0.5mA / 1min
MTBF	MIL-HDBK-217F@25°C	2X10 ⁵ Hrs

Typical Product List									
Model	Input Voltage Range (VDC)		Output Voltage/Current (Vo/Io)		Input Current(mA) Nominal Voltage		Max. Capacitive Load	Ripple & Noise (Max.)	Efficiency (%)
	Nominal	Range	Voltage (V)	Current (mA)	Full load Typ.	No Load Typ.	uF	mVp-p	Typ.
Single Output Series:									
KW3-05S3V3E	5	4.5 - 9	3.3	700	634	16	2200	100	73
KW3-05S05E			5	600	811	47	2200		74

KW3-05S09E			9	333	770	51	680		78
KW3-05S12E			12	250	789	50	680		76
KW3-05S15E			15	200	769	54	470		78
KW3-05S24E			24	125	769	67	330		78
KW3-12S05E			5	600	321	16	2200		78
KW3-12S12E			12	250	313	20	680		80
KW3-12S15E			15	200	313	22	470		80
KW3-12S24E			24	125	313	29	330		80
KW3-24S3V3E			3.3	600	110	12	220		77
KW3-24S05E			5	600	156	8	2200		80
KW3-24S12E			12	250	156	10	680		80
KW3-24S15E			15	200	152	11	470		82
KW3-24S24E			24	125	152	13	330	100	82
KW3-48S05EA			5	600	82	4.5	2200		76
KW3-48S12E			12	250	78	5	680		80
KW3-48S15E			15	200	78	6	470		80
KW3-48S24E			24	125	78	7	330		80
Positive Negative Dual Output Series:									
*KW3-05D05E			±5	±300	811	47	1000		74
KW3-05D12E			±12	±125	789	50	470		76
KW3-05D15E			±15	±100	769	54	330		78
KW3-05D24E			±24	±62	769	67	100		78
KW3-12D05E			±5	±300	321	16	1000	100	78
KW3-12D12E			±12	±125	313	20	470		80
KW3-12D15E			±15	±100	313	22	330		80
*KW3-12D24E			±24	±62	313	29	100		80
KW3-24D05E			±5	±300	156	8	1000		80
KW3-24D12E			±12	±125	156	10	470		80
KW3-24D15E			±15	±100	152	11	330		82
KW3-24D24E			±24	±62	152	13	100	100	82
*KW3-48D05E			±5	±300	82	4.5	1000		76
*KW3-48D12E			±12	±125	78	5	470		80

*KW3-48D15E		±15	±100	78	6	330	80
*KW3-48D24E		±24	±62	78	7	100	80

Note: 1. "*" are models under developing.

2. To ensure this module operate efficiently and reliably, the minimum output load could not be less than 10% of the nominal load during operation. If the actual output power is too small, please connect a resistor in parallel at the output, the resistance recommended equal to 10% nominal power.

Characteristic Curve

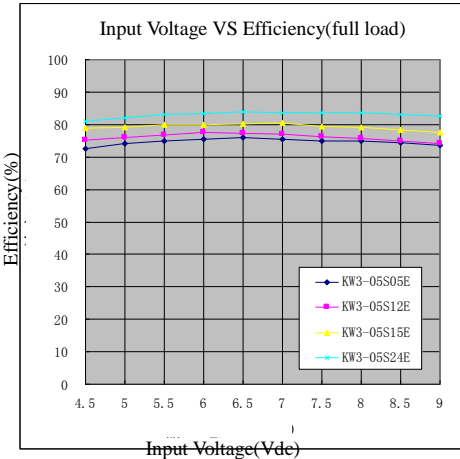

Photo 1

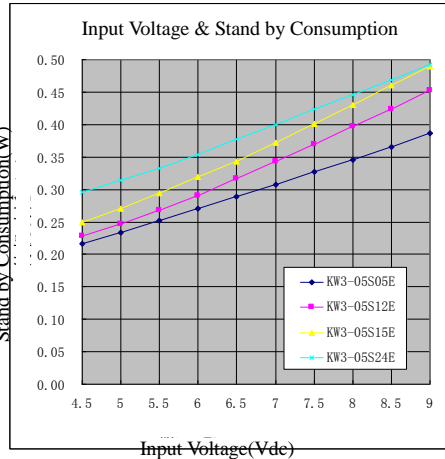

Photo 2

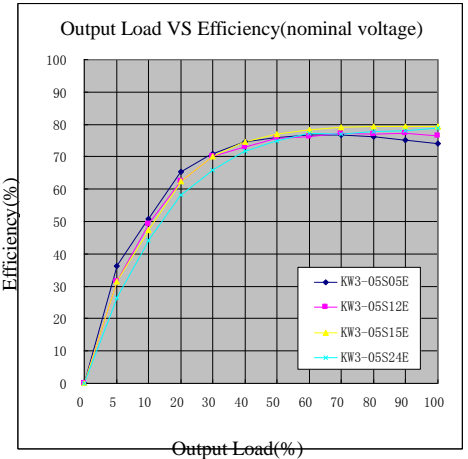

Photo 3

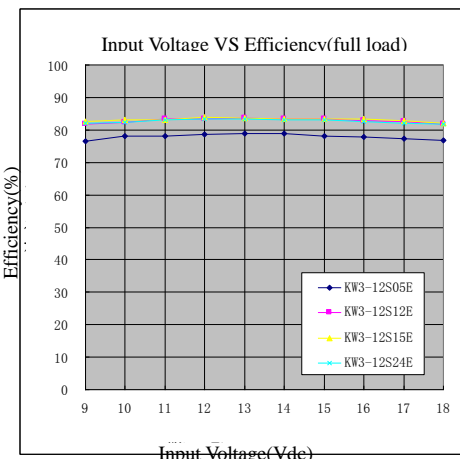

Photo 4

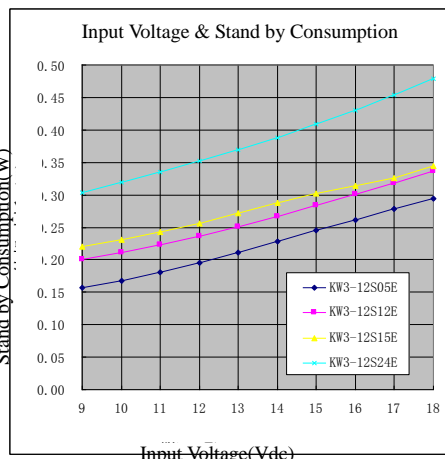

Photo 5

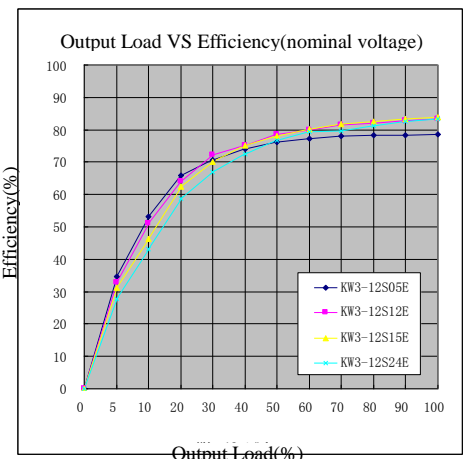

Photo 6

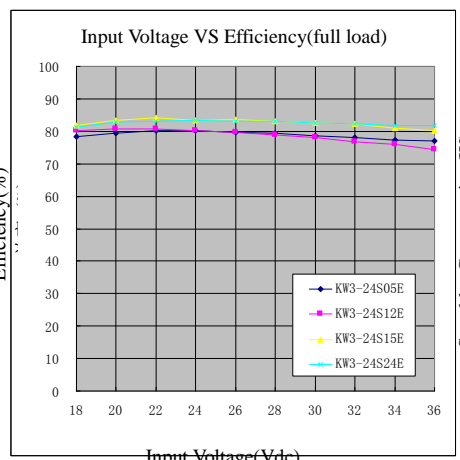

Photo 7

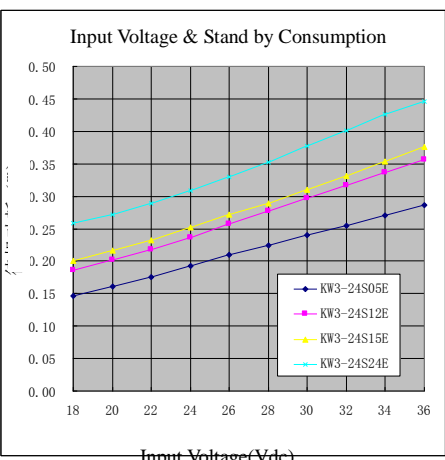

Photo 8

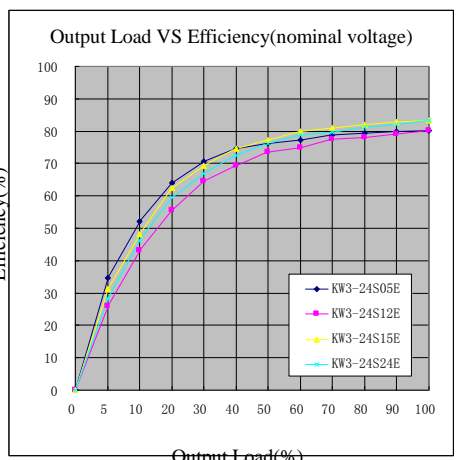
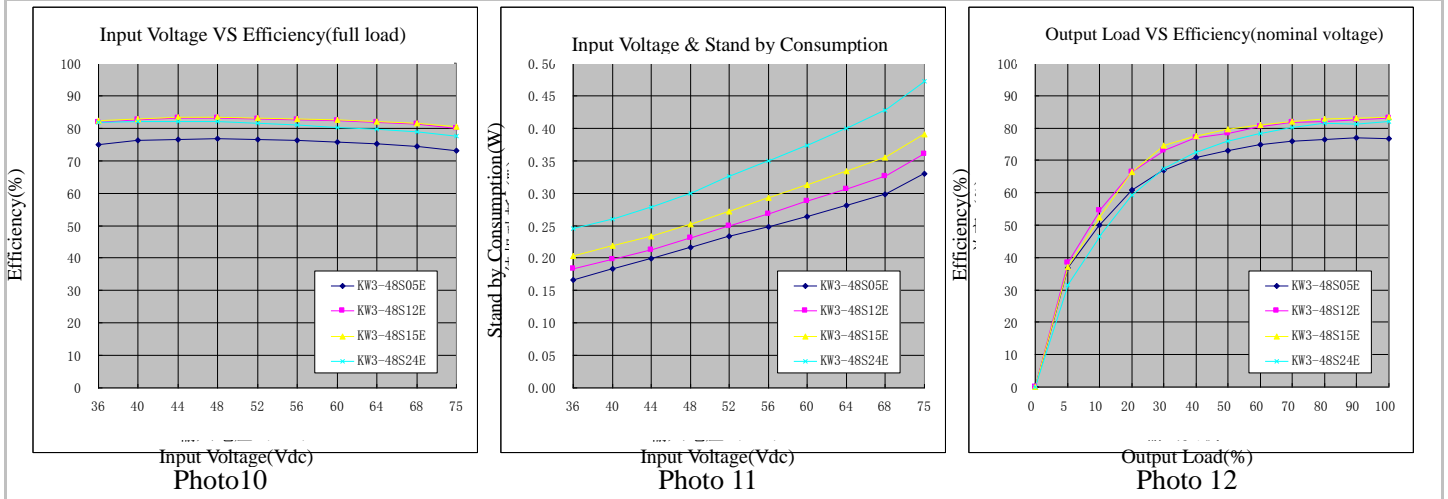
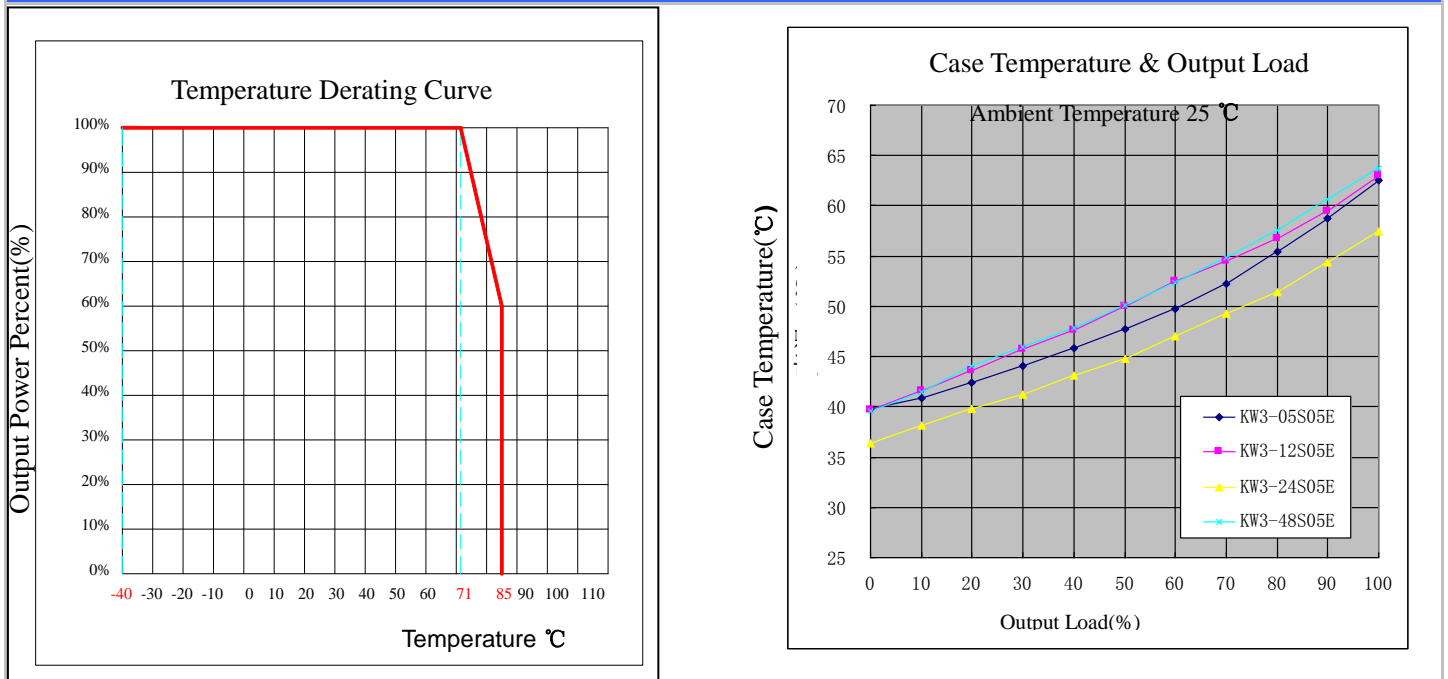

Photo 9



Note: Photo 1,2,3 are 5V input series ; Photo 4,5,6 are 12V input series ; Photo 7,8,9 are 24V input series; Photo 10,11,12 are 48V input series.

Temperature Curve



Packing Dimension, Pin Function, Recommended PCB layout

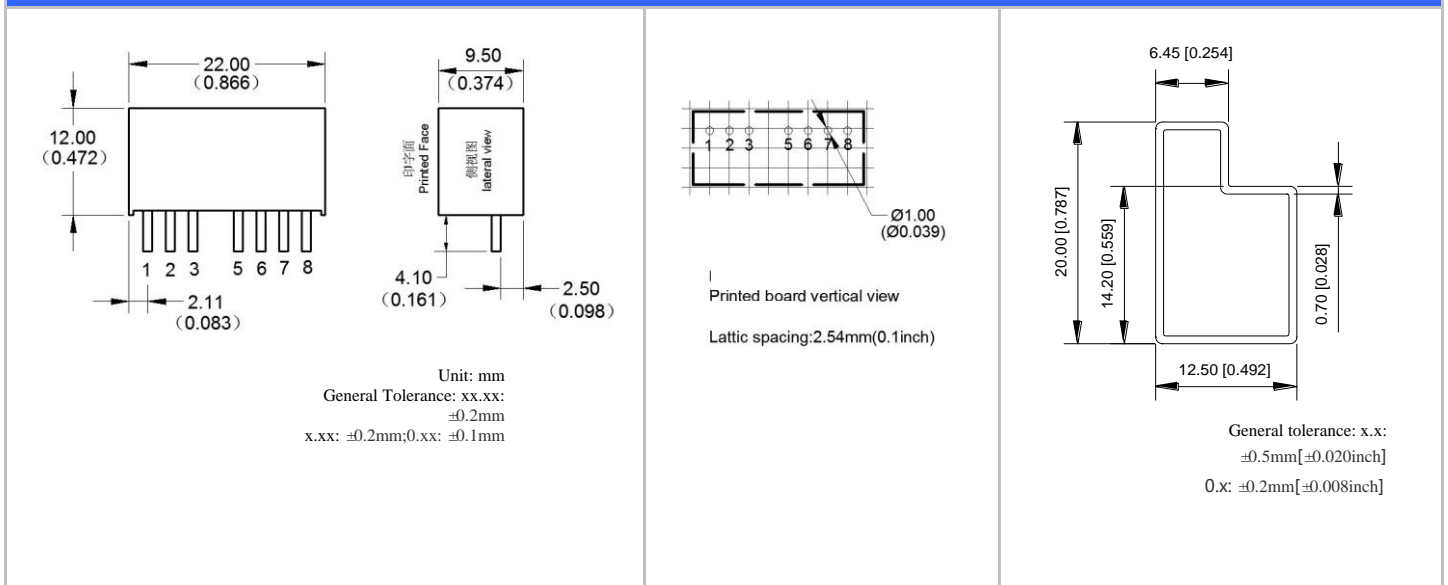

Pin Function	Single (S)	1	2	3	4	5	6	7	8
		GND	+Vin	Ctrl	---	NC	+Vo	0V	CS
	± Dual Output (D)	1	2	3	4	5	6	7	8
		GND	+Vin	Ctrl	---	NC	+Vo	0V	-Vo

Note: if the definition of pin is not in accordance with the manual, please refer to the label on actual item.

Dimension

Packing Code	L x W x H	
E	22 × 9.5 × 12mm	0.866 × 0.374 × 0.472inch

Design and Application Circuit Recommended

1.CS terminal

This terminal provides a connection point to connect the inside main filter capacitor of output terminal for the DC/DC converter(capacitor positive) , and can further improve the output ripple and noise (Normal CS≤47uF) through connecting a low ESR capacitor between this terminal and the 7 pin (capacitor negative).

2.Output Load Request

a. To ensure this module operate efficiently and reliably, the minimum load could not be less than 10% of the nominal load. If the actual power is too small, please connect a resistor in parallel at output terminal, the resistance equal to 10% nominal load. If use positive negative dual output product, please try to avoid big unbalances between loads, or the original output voltage accuracy cannot be ensured.

b. The maximum capacitive load is tested under nominal input full load; if use it under no load condition, should try to decrease the output capacitive load or connect a resistor in parallel at output terminal, the resistance equal to 10% nominal load, otherwise it may cause the output voltage be un-stable or even exceed the original output voltage accuracy range

3.Recommend Circuit

DC/DC test circuit: If you want to further decrease input& output ripple, the capacitance of external capacitor can be increased properly, but the maximum capacitance of the filter capacitor should be less than the maximum capacitive load, otherwise it will make it difficult to turn-on the module.

Normal Recommend: Ci:100uF (5V&12V) / 10uF (24V&48V)

Li:4.7uH~120uH

CS:10uF~22uF

Co:100uF (Typ.)

Lo;2.2uH~10uH

C1:47nF/100V

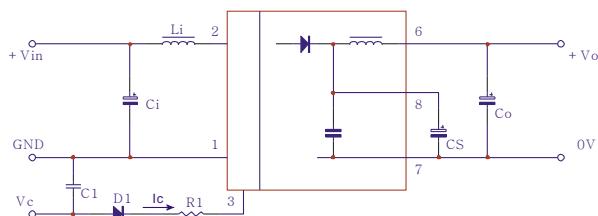

Single Output

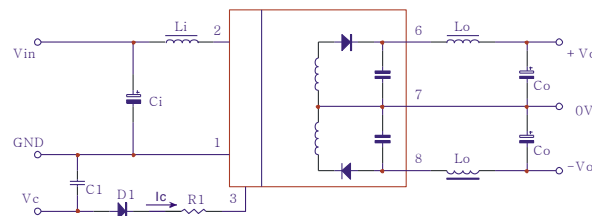

Positive Negative Dual Output

Photo 13

4. CTRL Terminal

Suspended or high resistance, output of module runs normally;
Connect to high level(relative to input ground), module turns off.

Note: The proper current flowing into this pin is 5-10mA, It will cause permanent damage to module if the current exceed its maximum value(typically 20mA). The R is calculated according to the following formula:

$$R = \frac{V_c - V_d - 0.7}{I_c} - 330 \quad (\text{ See Photo 13 })$$

V_c is input voltage of Ctrl pin, V_d is forward voltage drop of D1, 0.7V and 330Ω are module's bipolar junction transistor voltage drop and inside connecting resistor of input terminal for control pin respectively, I_c is the input current of control terminal.

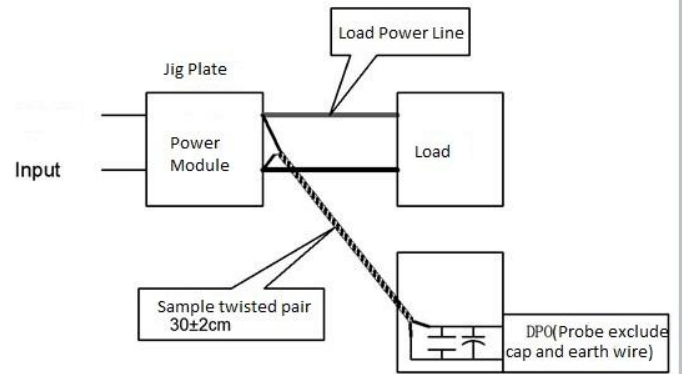

5. Input Current

When unstable power supply connected, please ensure that the output voltage fluctuating range of power supply and the ripple voltage is within the module's index, output current of input power supply must meet instant turn-on current I_p of the DC/DC converter(see below picture)

Normally: $I_p \leq 1.4 * I_{in_max}$

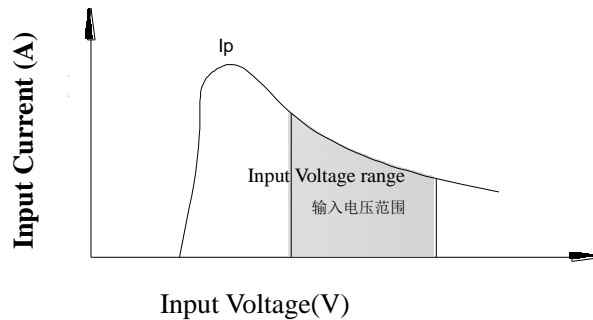

6. Ripple & Noise Test: (Twisted Pair Method 20MHZ bandwidth)

Test Method:

a. 12# twisted pair to connect, Oscilloscope bandwidth set as 20MHz, 100M bandwidth probe, terminated with 0.1uF polypropylene capacitor and 47uF high frequency low resistance electrolytic capacitor in parallel, oscilloscope set as Sample pattern.

b. Input terminal connect to power supply, output terminal connect to electronic load through jig plate, Use 30cm±2 cm sampling line, Power line selected from corresponding diameter wire with insulation according to the flow of output current.

Note:

1. This product cannot be used in parallel, and do not support hot-plugging;
2. All index testing methods in this datasheet are based on our Company's corporate standards
3. The product specification may be changed at any time without prior notice.

X-ON Electronics

Largest Supplier of Electrical and Electronic Components

Click to view similar products for [Power Management Modules](#) category:

Click to view products by [Aipu](#) manufacturer:

Other Similar products are found below :

[FPF1C2P5BF07A](#) [FPF1C2P5MF07AM](#) [FH2000NPBAP](#) [B0505S-2W](#) [HLK-5D1205](#) [HLK-10D4805B](#) [B0505XT-1WR2-R](#) [B0505S-1W](#)
[B1224S-1WR2](#) [AP24N20-HV](#) [TAS25-24-W](#) [TAS10-5-W](#) [TAS10-24-W](#) [TAD10-1505-NI](#) [LS03-13B09R3](#) [HCES1-05D12](#) [HCS2-12D15](#)
[DC2626A](#) [DFR0756](#) [CS-POWEEVER-02](#) [CS-POWEEVER-01](#) [01D-6R5-2A](#) [11D-05S05NANL](#) [12D-03S05N3KVAC](#) [12D-](#)
[05S05N3WNL](#) [12D-05S05RNL](#) [12D-24S05R2W](#) [12DA-05S05N2W](#) [13D-05S05NCNL](#) [13DS1-12D09NNL](#) [13DSB-05S05N1.5KV](#) [14D-](#)
[12S03R1KVNL](#) [14DB-05S05N1.5KV](#) [14DZ-05S05R2W](#) [MEE1S0309SC](#) [22D-12D12NCNL](#) [EN5322QI](#) [LTM4624EY#PBF](#) [1SP0340V2M0-](#)
[45](#) [IGD515EI](#) [1SP0335D2S1-5SNA0750G650300](#) [2SP0115T2A0-FF600R12ME4](#) [2SP0115T2A0-12](#) [2SD106AI-17](#) [UL](#) [2SC0635T2A1-45](#)
[2SC0115T2A0-12](#) [2SC0108T2F1-17](#) [1SD210F2-MBN1200H45E2-H_Opt1](#) [A0505S-1W](#) [A0505S-1WR2](#)