



PMC271/PMS271 Series

8-bit ADC Field Programmable Processor Array (FPPA™) 8-bit Controller

Data Sheet

Version 0.04– June 11, 2015

Copyright © 2015 by PADAUK Technology Co., Ltd., all rights reserved

10F-2, No. 1, Sec. 2, Dong-Da Road, Hsin-Chu 300, Taiwan, R.O.C.

TEL: 886-3-532-7598  www.padauk.com.tw



PMC271/PMS271 Series 8-bit ADC FPPA™ 8-bit Controller

IMPORTANT NOTICE

PADAUK Technology reserves the right to make changes to its products or to terminate production of its products at any time without notice. Customers are strongly recommended to contact PADAUK Technology for the latest information and verify whether the information is correct and complete before placing orders.

PADAUK Technology products are not warranted to be suitable for use in life-support applications or other critical applications. PADAUK Technology assumes no liability for such applications. Critical applications include, but are not limited to, those that may involve potential risks of death, personal injury, fire or severe property damage.

PADAUK Technology assumes no responsibility for any issue caused by a customer's product design. Customers should design and verify their products within the ranges guaranteed by PADAUK Technology. In order to minimize the risks in customers' products, customers should design a product with adequate operating safeguards.

Table of Contents

1. Features.....	8
1.1. Special Features	8
1.2. System Features	8
1.3. CPU Features	8
1.4. Package Information	9
2. General Description and Block Diagram	10
3. Pin Assignment and Description.....	11
4. Device Characteristics	16
4.1. DC/AC Characteristics	16
4.2. Absolute Maximum Ratings	18
4.3. Typical IHRC Frequency vs. VDD (calibrated to 16MHz)	18
4.4. Typical ILRC Frequency vs. VDD	18
4.5. Typical IHRC Frequency vs. Temperature (calibrated to 16MHz)	19
4.6. Typical ILRC Frequency vs. Temperature	19
4.7. Typical Operating Current vs. VDD and CLK=IHRC/n.....	20
4.8. Typical Operating Current vs. VDD and CLK=ILRC/n	20
4.9. Typical Lowest Operating Current vs. VDD and CLK=ILRC/n	21
4.10. Typical Operating Current vs. VDD @CLK=32KHz EOSC/n	22
4.11. Typical Operating Current vs. VDD @CLK=1MHz EOSC/n	23
4.12. Typical Operating Current vs. VDD @CLK=4MHz EOSC/n	24
4.13. Typical IO pull high resistance	25
4.14. Typical IO driving current (I _{OH}) and sink current (I _{OL})	25
4.15. Typical IO input high / low threshold voltage (V _{IH} /V _{IL})	25
4.16. Typical (VDD/2) Bias output voltage	25
5. Functional Description.....	26
5.1. Processing Units	26
5.1.1. Program Counter	27
5.1.2. Stack Pointer	27
5.1.3. Single FPP mode.....	28
5.2. Program Memory – OTP.....	29
5.2.1. Program Memory Assignment	29
5.2.2. Example of Using Program Memory for Two FPP mode.....	29
5.2.3. Example of Using Program Memory for Single FPP mode	30
5.3. Program Structure.....	31
5.3.1. Program structure of two FPP units mode.....	31
5.3.2. Program structure of single FPP mode	31
5.4. Boot Procedure	32

5.5.	Data Memory – SRAM	33
5.6.	Arithmetic and Logic Unit	33
5.7.	Oscillator and clock	34
5.7.1.	Internal High RC oscillator and Internal Low RC oscillator	34
5.7.2.	Chip calibration	34
5.7.3.	IHRC Frequency Calibration and System Clock	34
5.7.4.	External Crystal Oscillator	36
5.7.5.	System Clock and LVR levels	37
5.7.6.	System Clock Switching	38
5.8.	16-bit Timer (Timer16)	39
5.9.	Watchdog Timer	40
5.10.	Interrupt	41
5.11.	Power-Save and Power-Down	42
5.11.1.	Power-Save mode (“stopexe”)	43
5.11.2.	Power-Down mode (“stopsys”)	44
5.11.3.	Wake-up	45
5.12.	IO Pins	46
5.13.	Reset and LVR	47
5.13.1.	Reset	47
5.13.2.	LVR reset	47
5.14.	LCD Half VDD Bias Voltage	47
5.15.	Analog-to-Digital Conversion (ADC) module	48
5.15.1.	The input requirement for AD conversion	49
5.15.2.	ADC clock selection	50
5.15.3.	AD conversion	50
5.15.4.	Configuring the analog pins	50
6.	IO Registers	51
6.1.	ACC Status Flag Register (flag), IO address = 0x00	51
6.2.	FPP unit Enable Register (fppen), IO address = 0x01	51
6.3.	Stack Pointer Register (sp), IO address = 0x02	51
6.4.	Clock Mode Register (clkmd), IO address = 0x03	52
6.5.	Interrupt Enable Register (inten), IO address = 0x04	52
6.6.	Interrupt Request Register (intrq), IO address = 0x05	52
6.7.	Timer 16 mode Register (t16m), IO address = 0x06	53
6.8.	General Data register for IO (gdio), IO address = 0x07	53
6.9.	External Oscillator setting Register (eoscr, write only), IO address = 0x0a	53
6.10.	IHRC oscillator control Register (ihrcr, write only), IO address = 0x0b	54
6.11.	Interrupt Edge Select Register (integs), IO address = 0x0c	54
6.12.	Port A Digital Input Enable Register (padier), IO address = 0x0d	55
6.13.	Port B Digital Input Enable Register (pbdiier), IO address = 0x0e	56
6.14.	Port A Data Registers (pa), IO address = 0x10	57
6.15.	Port A Control Registers (pac), IO address = 0x11	57

6.16.	Port A Pull-High Registers (<i>paph</i>), IO address = 0x12	57
6.17.	Port B Data Registers (<i>pb</i>), IO address = 0x14	57
6.18.	Port B Control Registers (<i>pbcr</i>), IO address = 0x15	57
6.19.	Port B Pull-High Registers (<i>pbph</i>), IO address = 0x16	57
6.20.	ADC Control Register (<i>adcc</i>), IO address = 0x20	58
6.21.	ADC Mode Register (<i>adcm</i> , write only), IO address = 0x21	58
6.22.	ADC Result Register (<i>adcr</i> , read only), IO address = 0x22	59
6.23.	ADC Reference High Control Register (<i>adcrhc</i>), IO address = 0x1c	59
6.24.	RESET Status Register (<i>rstst</i>), IO address = 0x25	59
6.23.	MISC Register (<i>misc</i>), IO address = 0x3b	60
7.	Instructions	61
7.1.	Data Transfer Instructions.....	62
7.2.	Arithmetic Operation Instructions.....	67
7.3.	Shift Operation Instructions.....	69
7.4.	Logic Operation Instructions	70
7.5.	Bit Operation Instructions.....	73
7.6.	Conditional Operation Instructions.....	74
7.7.	System control Instructions.....	76
7.8.	Summary of Instructions Execution Cycle	78
7.9.	Summary of affected flags by Instructions	79
8.	Special Notes	80
8.1.	Using IC	80
8.1.1.	IO pin usage and setting	80
8.1.2.	Interrupt.....	81
8.1.3.	System clock switching	81
8.1.4.	Power down mode, wakeup and watchdog.....	82
8.1.5.	TIMER time out	82
8.1.6.	Using ADC.....	83
8.1.7.	LVR	83
8.1.8.	Differences in command timing between single / double FPPA mode	83
8.1.9.	Program writing	83
8.2.	Using ICE.....	84
8.2.1.	Emulating PMC271/PMS271 series IC on ICE PDK3S-I-001/002/003	84
8.2.2.	Important Notice for ICE operation.....	85

Revision History:

Revision	Date	Description
0.01	2013/12/10	1 ST version
0.02	2014/2/19	Add chapter 8 Special Notes
0.03	2014/12/22	Amend PMS271 operating temperature
0.04	2015/6/11	<ol style="list-style-type: none">1. Amend page 7: PMC271/PMS271 Band-gap mV2. Amend 1.1 PMS271 series operating temperature range to -20°C ~ 70°C3. Amend 4.1 Band-gap reference voltage

Major Differences between PDK22C and PMC271/PMS271

There are many differences between PDK22C and PMC271/PMS271. The table below only shows the major differences between them.

Item	Function	PDK22C	PMC271/PMS271
1	IO Pin	15 IO + 1 input	16 IO
2	IO capability	15mA@5.0V	10mA@5.0V
3	Band-gap	N/A	+/- 60mV(@1.20V) after calibration
4	LVR	5 levels LVR setting	8 levels LVR setting
5	Fast wake up	N/A	Yes
6	Single FPPA mode	N/A	Yes
7	ADC channel	4 channels	8 channels
8	External RC and external clock source mode	Yes	No
9	T16 clock source	Support external RC oscillator	Not support
10	LCD VDD/2 bias voltage	Enabled by code option	Controlled by <i>misc.4</i>
11	<i>misc</i> register	N/A	Yes
12	Port digital input configure registers	<i>adcdi</i> register	<i>padier</i> and <i>pbdi</i>
13	IHRC option command	.ADJUST_OTP_IHRCR	.ADJUST_IC
14	WDT timeout period	1024 ILRC cycles	4 selectable periods

Procedure for converting code from PDK22C to PMC271/PMS271

Please follow the below steps for converting codes from PDK22C to PMC271/PMS271:

1. Go through the PMC271/PMS271 datasheet and user guide;
2. Modify the source code engineering file “.pre”; change “.chip PDK22CXXX” to “.chip PMC271” or “.chip PMS271”
3. Press “Build” and then IDE will show some errors and warnings.
4. Modify the source code correspondingly until all errors have been solved.
5. Save and build the project files again.
6. Write to a real chip and test its functions in detail.
7. Back to the step 3 if necessary.
8. Contact our FAE at fae@padauk.com.tw if you still have any problems.

1. Features

1.1. Special Features

- ◆ PMC271 series:
 - ◇ High EFT series
 - ◇ Operating temperature range: -40°C ~ 85°C
- ◆ PMS271 series:
 - ◇ General purpose series
 - ◇ Please don't apply to AC RC step-down powered, high power ripple or high EFT requirement application
 - ◇ Operating temperature range: -20°C ~ 70°C

1.2. System Features

- ◆ Clock sources: internal high RC oscillator, internal low RC oscillator and external crystal oscillator
- ◆ Internal High RC Oscillator (IHRC) frequency
- ◆ Band-gap circuit to provide 1.20V reference voltage
- ◆ One hardware 16-bit timer
- ◆ Total 8-channel 8-bit ADC, including one channel for band-gap reference voltage input
- ◆ Built-in half VDD bias voltage generator for LCD application
- ◆ Support fast wake-up
- ◆ Eight levels of LVR reset ~ 4.1V, 3.6V, 3.1V, 2.8V, 2.5V, 2.2V, 2.0V, 1.8V
- ◆ 16 IO pins with 10mA capability and optional pull-high resistor
- ◆ Two external interrupt pins
- ◆ Every IO pin can be configured to enable wake-up function
- ◆ Operating frequency range:
 - DC ~ 8MHz@VDD ≥ 3.3V; DC ~ 4MHz@VDD ≥ 2.5V; DC ~ 2MHz@VDD ≥ 2.2V
- ◆ Operating voltage range: 2.2V ~ 5.5V
- ◆ Low power consumption

$I_{\text{operating}} \sim 1.7\text{mA}@1\text{MIPS}, V_{\text{DD}}=5.0\text{V}$	$I_{\text{operating}} \sim 8\text{uA}@ILRC=12\text{KHz}, V_{\text{DD}}=3.3\text{V}$
$I_{\text{powerdown}} \sim 0.7\text{uA}@V_{\text{DD}}=5.0\text{V}$	$I_{\text{powerdown}} \sim 0.4\text{uA}@V_{\text{DD}}=3.3\text{V}$

1.3. CPU Features

- ◆ Operating modes: Two processing units FPPA™ mode or Traditional one processing unit mode
- ◆ 1KW OTP program memory
- ◆ 64 Bytes data RAM
- ◆ 101 powerful instructions
- ◆ Most instructions are 1T execution cycle
- ◆ Programmable stack pointer and adjustable stack level
- ◆ All data memories are available for use as an index pointer
- ◆ Separated IO space and memory space

1.4. Package Information

◆ PMC271 series

PMC271 - S14: SOP14 (150mil);
PMC271 - S16: SOP16 (150mil) ;
PMC271 - S18: SOP18 (300mil) ;
PMC271 - Y16: SSOP16 (150mil);
PMC271 - Y20: SSOP20 (150mil);
PMC271 - D14: DIP14 (300mil);

◆ PMS271 series

PMS271 - S14: SOP14 (150mil);
PMS271 - S16: SOP16 (150mil) ;
PMS271 - S18: SOP18 (300mil) ;
PMS271 - Y16: SSOP16 (150mil);
PMS271 - Y20: SSOP20 (150mil);
PMS271 - D14: DIP14 (300mil);

2. General Description and Block Diagram

The PMC271/PMS271 series is an ADC-Type of PADAUK’s parallel processing, fully static, OTP-based CMOS two 8 bit processor array that can execute two peripheral functions in parallel. Besides operated in two processing units, PMC271/PMS271 can act as traditional MCU in one processing unit. The PMC271/PMS271 employs RISC architecture based on patented FPPA™ (Field Programmable Processor Array) technology and most the instructions are executed in one cycle except that few instructions are two cycles that handle indirect memory access.

1KW bits OTP program memory and 64 bytes data SRAM are inside for two FPP units using, PMC271/PMS271 provides one hardware 16-bit timer, one 8 channels 8-bit ADC and hardware circuit to generate half VDD bias voltage for LCD application. The functions for peripheral devices like UART and PWM can be easily implemented by using FPPA™ unique architecture.

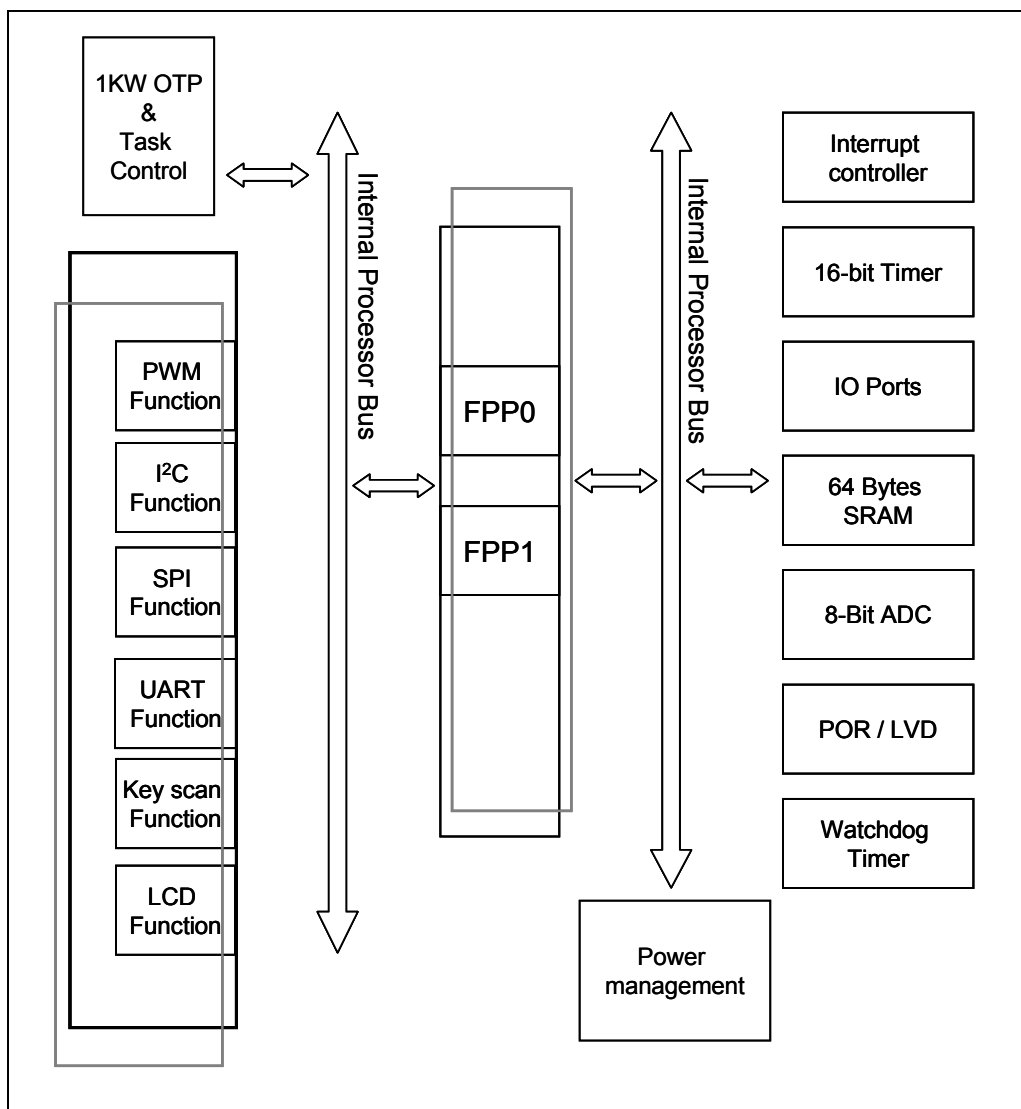

3. Pin Assignment and Description

◆ PMC271 series

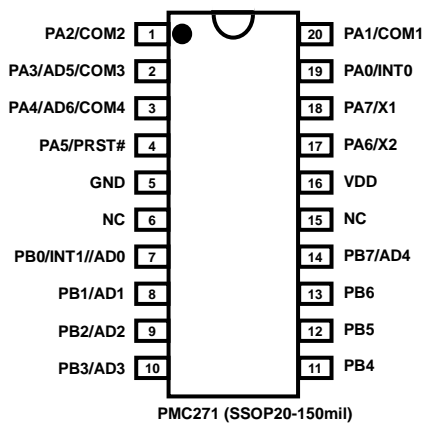
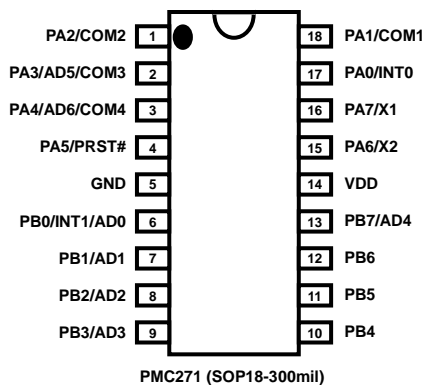
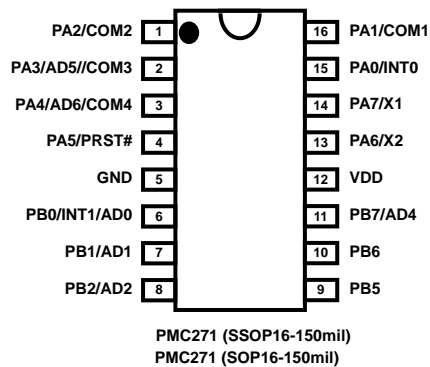
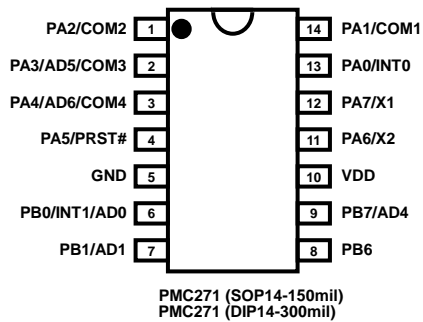

PMC271/PMS271 Series 8-bit ADC FPPA™ 8-bit Controller

◆ PMS271 series

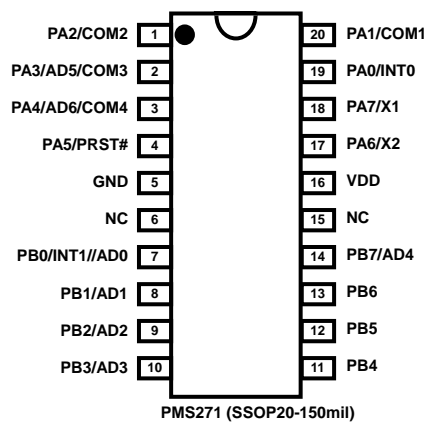
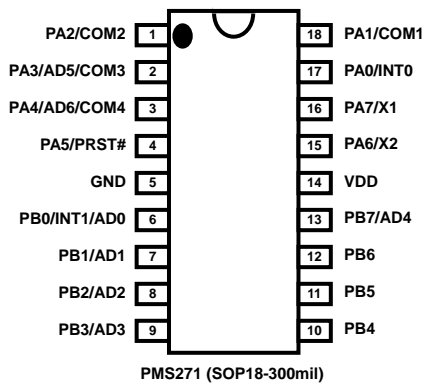
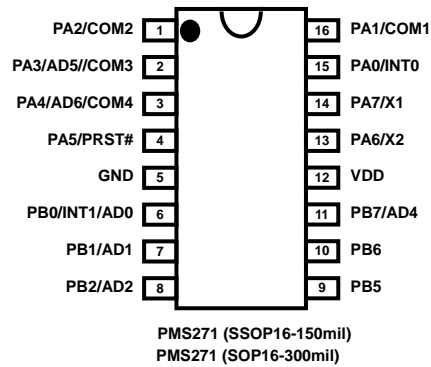
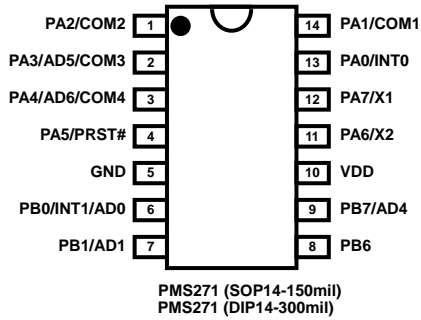

Pin Description

Pin Name	Pin & Buffer Type	Description
PA7/X1	IO ST / CMOS / Analog	<p>The functions of this pin can be:</p> <p>(1) Bit 7 of port A. It can be configured as input or output with pull-up resistor.</p> <p>(2) X1 (input) when crystal oscillator is used.</p> <p>If this pin is used for crystal oscillator, bit 7 of padier register must be programmed “0” to avoid leakage current. This pin can be used to wake-up system during sleep mode; however, wake-up function is also disabled if bit 7 of padier register is “0”.</p>
PA6/X2	IO ST / CMOS / Analog	<p>The functions of this pin can be:</p> <p>(1) Bit 6 of port A. It can be configured as input or output with pull-up resistor.</p> <p>(2) X2 (output) when crystal oscillator is used.</p> <p>If this pin is used for crystal oscillator, bit 6 of padier register must be programmed “0” to avoid leakage current. This pin can be used to wake-up system during sleep mode; however, wake-up function is also disabled if bit 6 of padier register is “0”.</p>
PA5/PRST#	IO ST / CMOS	<p>The functions of this pin can be:</p> <p>(1) Bit 5 of port A. It can be configured as input or open-drain output pin. <u>Please notice that there is no pull-up resistor in this pin.</u></p> <p>(2) Hardware reset.</p> <p>This pin can be used to wake-up system during sleep mode; however, wake-up function is also disabled if bit 5 of padier register is “0”.</p> <p><u>Please put 33Ω resistor in series to have high noise immunity when this pin is in input mode.</u></p>
PA4/AD6/COM4	IO ST / CMOS / Analog	<p>The functions of this pin can be:</p> <p>(1) Bit 4 of port A. It can be configured as input or output with pull-up resistor.</p> <p>(2) Channel 6 input of ADC.</p> <p>(3) COM4 for LCD to provide $(1/2 VDD)$ for LCD bias voltage.</p> <p>If this pin acts as analog input, bit 4 of padier register must be programmed “0” to avoid leakage current. This pin can be used to wake-up system during sleep mode; however, wake-up function from this pin is also disabled when bit 4 of padier register is “0”.</p>
PA3/AD5/COM3	IO ST / CMOS / Analog	<p>The functions of this pin can be:</p> <p>(1) Bit 3 of port A. It can be configured as input or output with pull-up resistor.</p> <p>(2) Channel 5 input of ADC.</p> <p>(3) COM3 for LCD to provide $(1/2 VDD)$ for LCD bias voltage.</p> <p>If this pin acts as analog input, bit 3 of padier register must be programmed “0” to avoid leakage current. This pin can be used to wake-up system during sleep mode; however, wake-up function from this pin is also disabled when bit 3 of padier register is “0”.</p>

Pin Name	Pin Type & Buffer Type	Description
PA2/COM2	IO ST / CMOS	<p>The functions of this pin can be:</p> <p>(1) Bit 2 of port A. It can be configured as input or output with pull-up resistor.</p> <p>(2) COM2 for LCD to provide $(1/2 VDD)$ for LCD bias voltage.</p> <p>This pin can be used to wake-up system during sleep mode; however, wake-up function from this pin is also disabled when bit 2 of padier register is “0”.</p>
PA1/COM1	IO ST / CMOS	<p>The functions of this pin can be:</p> <p>(1) Bit 1 of port A. It can be configured as input or output with pull-up resistor.</p> <p>(2) COM1 for LCD to provide $(1/2 VDD)$ for LCD bias voltage.</p> <p>This pin can be used to wake-up system during sleep mode; however, wake-up function from this pin is also disabled when bit 1 of padier register is “0”.</p>
PA0/INT0	IO ST / CMOS	<p>The functions of this pin can be:</p> <p>(1) Bit 0 of port A. It can be configured as input or output with pull-up resistor.</p> <p>(2) External interrupt line 0. <u>Both rising edge and falling edge are accepted to request interrupt service.</u></p> <p>This pin can be used to wake-up system during sleep mode, however, wake-up function from this pin is also disabled when bit 0 of padier register is “0”. <u>Both rising edge and falling edge are accepted to request interrupt service.</u></p>
PB7/AD4	IO ST / CMOS / Analog	<p>The functions of this pin can be:</p> <p>(1) Bit 7 of port B. It can be configured as input or output with pull-up resistor.</p> <p>(2) Channel 4 input of ADC.</p> <p>If this pin acts as analog input, bit 7 of pbdier register must be programmed “0” to avoid leakage current. This pin can be used to wake-up system during sleep mode; however, wake-up function from this pin is also disabled when bit 7 of pbdier register is “0”.</p>
PB6	IO ST / CMOS	<p>The function of this pin is Bit 6 of port B. It can be configured as input or output with pull-up resistor.</p> <p>This pin can be used to wake-up system during sleep mode; however, wake-up function from this pin is also disabled when bit 6 of pbdier register is “0”.</p>
PB5	IO ST / CMOS	<p>The function of this pin is Bit 5 of port B. It can be configured as input or output with pull-up resistor.</p> <p>This pin can be used to wake-up system during sleep mode; however, wake-up function from this pin is also disabled when bit 5 of pbdier register is “0”.</p>
PB4	IO ST / CMOS	<p>The function of this pin is Bit 4 of port B. It can be configured as input or output with pull-up resistor.</p> <p>This pin can be used to wake-up system during sleep mode; however, wake-up function from this pin is also disabled when bit 4 of pbdier register is “0”.</p>

Pin Name	Pin Type & Buffer Type	Description
PB3/AD3	IO ST / CMOS / Analog	<p>The functions of this pin can be:</p> <p>(1) Bit 3 of port B. It can be configured as input or output with pull-up resistor.</p> <p>(2) Channel 3 input of ADC.</p> <p>If this pin acts as analog input, bit 3 of <i>pbdierr</i> register must be programmed “0” to avoid leakage current. This pin can be used to wake-up system during sleep mode; however, wake-up function from this pin is also disabled when bit 3 of <i>pbdierr</i> register is “0”.</p>
PB2/AD2	IO ST / CMOS / Analog	<p>The functions of this pin can be:</p> <p>(1) Bit 2 of port B. It can be configured as input or output with pull-up resistor.</p> <p>(2) Channel 2 input of ADC.</p> <p>If this pin acts as analog input, bit 2 of <i>pbdierr</i> register must be programmed “0” to avoid leakage current. This pin can be used to wake-up system during sleep mode; however, wake-up function from this pin is also disabled when bit 2 of <i>pbdierr</i> register is “0”.</p>
PB1/AD1	IO ST / CMOS / Analog	<p>The functions of this pin can be:</p> <p>(1) Bit 1 of port B. It can be configured as input or output with pull-up resistor.</p> <p>(2) Channel 1 input of ADC.</p> <p>If this pin acts as analog input, bit 1 of <i>pbdierr</i> register must be programmed “0” to avoid leakage current. This pin can be used to wake-up system during sleep mode; however, wake-up function from this pin is also disabled when bit 1 of <i>pbdierr</i> register is “0”.</p>
PB0/INT1/AD0	IO ST / CMOS / Analog	<p>The functions of this pin can be:</p> <p>(1) Bit 0 of port B. It can be configured as input or output with pull-up resistor.</p> <p>(2) External interrupt line 1. <u>Both rising edge and falling edge are accepted to request interrupt service.</u></p> <p>(3) Channel 0 input of ADC.</p> <p>If this pin acts as analog input, bit 0 of <i>pbdierr</i> register must be programmed “0” to avoid leakage current. This pin can be used to wake-up system during sleep mode; however, wake-up function from this pin is also disabled when bit 0 of <i>pbdierr</i> register is “0”.</p>
VDD		Positive power
GND		Ground
<p>Notes: IO: Input/Output; ST: Schmitt Trigger input; Analog: Analog input pin; CMOS: CMOS voltage level</p>		

4. Device Characteristics

4.1. DC/AC Characteristics

All data are acquired under the conditions of $T_a = -40^\circ\text{C} \sim 85^\circ\text{C}$, $V_{DD}=5.0\text{V}$, $f_{SYS}=2\text{MHz}$ unless noted.

Symbol	Description	Min	Typ	Max	Unit	Conditions
V_{DD}	Operating Voltage	2.2	5.0	5.5	V	$f_{SYS} = 2\text{MHz}$
f_{SYS}	System clock* = IHRC/2 IHRC/4 & crystal oscillator IHRC/8 & crystal oscillator ILRC	0 0 0	24K	8M 4M 2M	Hz	Under_20ms_Vdd_ok**=Y/N $V_{DD} \geq 3.0\text{V} / V_{DD} \geq 3.3\text{V}$ $V_{DD} \geq 2.5\text{V} / V_{DD} \geq 2.8\text{V}$ $V_{DD} \geq 2.2\text{V} / V_{DD} \geq 2.2\text{V}$ $V_{DD} = 5.0\text{V}$
I_{OP}	Operating Current		1.7 8		mA uA	$f_{SYS}=1\text{MIPS}@5.0\text{V}$ $f_{SYS}=ILRC=12\text{KHz}@3.3\text{V}$
I_{PD}	Power Down Current (by stopsys command)		0.7 0.4		uA uA	$f_{SYS}= 0\text{Hz}, V_{DD}=5.0\text{V}$ $f_{SYS}= 0\text{Hz}, V_{DD}=3.3\text{V}$
I_{PS}	Power Save Current (by stopexe command)		0.4		mA	$V_{DD}=5.0\text{V}$; Band-gap, LVR, IHRC, ILRC, Timer16 modules are ON.
V_{IL}	Input low voltage for IO lines	0		$0.3V_{DD}$	V	
V_{IH}	Input high voltage for IO lines	$0.7 V_{DD}$		V_{DD}	V	
I_{OL}	IO lines sink current	7	10	13	mA	$V_{DD}=5.0\text{V}, V_{OL}=0.5\text{V}$
I_{OH}	IO lines drive current	-5	-7	-9	mA	$V_{DD}=5.0\text{V}, V_{OH}=4.5\text{V}$
V_{IN}	Input voltage	-0.3		$V_{DD}+0.3$	V	
$I_{INJ}(\text{PIN})$	Injected current on pin			1	mA	$V_{DD}+0.3 \geq V_{IN} \geq -0.3$
R_{PH}	Pull-high Resistance		62 100 210		K Ω	$V_{DD}=5.0\text{V}$ $V_{DD}=3.3\text{V}$ $V_{DD}=2.2\text{V}$
V_{BRD}	Low Voltage Detect Voltage * (Brown-out voltage)	3.86 3.35 2.84 2.61 2.37 2.04 1.86 1.67	4.15 3.60 3.05 2.80 2.55 2.20 2.00 1.80	4.44 3.85 3.26 3.00 2.73 2.35 2.14 1.93	V	
V_{BG}	Band-gap Reference Voltage (before calibration)	1.104* 1.109*	1.200* 1.200*	1.296* 1.291*	V	$V_{DD}=2.2\text{V} \sim 5.5\text{V}$ $-40^\circ\text{C} < T_a < 85^\circ\text{C}^*$ $-20^\circ\text{C} < T_a < 70^\circ\text{C}^*$
	Band-gap Reference Voltage * (after calibration)	1.140* 1.145*	1.200* 1.200*	1.260* 1.255*		$V_{DD}=2.2\text{V} \sim 5.5\text{V}$ $-40^\circ\text{C} < T_a < 85^\circ\text{C}^*$ $-20^\circ\text{C} < T_a < 70^\circ\text{C}^*$

PMC271/PMS271 Series

8-bit ADC FPPA™ 8-bit Controller

Symbol	Description	Min	Typ	Max	Unit	Conditions
f_{IHRC}	Frequency of IHRC after calibration *	15.68*	16*	16.32*	MHz	25°C, VDD=2.2V~5.5V
		14.72*	16*	17.28*		VDD=2.2V~5.5V, -40°C <Ta<85°C*
		14.88*	16*	17.12*		-20°C <Ta<70°C*
f_{ILRC}	Frequency of ILRC *	20.4*	24*	27.6*	KHz	VDD=5.0V, Ta=25°C
		15.6*	24*	32.4*		VDD=5.0V, -40°C <Ta<85°C*
		16.8*	24*	31.2*		VDD=5.0V, -20°C <Ta<70°C*
		10.2*	12*	13.8*		VDD=3.3V, Ta=25°C
		7.8*	12*	16.2*		VDD=3.3V, -40°C <Ta<85°C*
8.4*	12*	15.6*	VDD=5.0V, -20°C <Ta<70°C*			
V_{AD}	AD Input Voltage	0		VDD	V	
AD DNL	AD Differential Non-Linearity*		±0.5*		LSB	
AD INL	AD Integral Non-Linearity*		±1*		LSB	
$R_{(VDD/2)}$	(VDD/2) pull-up resistance		6.3		KΩ	@VDD=5V
	(VDD/2) pull-down resistance		7.0			@VDD=3.3V
$\Delta V_{(VDD/2)}$	Deviation of (VDD/2) output voltage		±1%	±3%		@VDD=5V
t_{INT}	Interrupt pulse width	30			ns	V _{DD} = 5.0V
V_{DR}	RAM data retention voltage*	1.5			V	In power-down mode.
t_{WDT}	Watchdog timeout period (T_{ILRC} is the clock period of ILRC)		2048		T_{ILRC}	misc[1:0]=00 (default)
			4096			misc[1:0]=01
			16384			misc[1:0]=10
			256			misc[1:0]=11
t_{SBP}	System boot-up period from power-on		1024		T_{ILRC}	Where T_{ILRC} is the clock period of ILRC
t_{WUP}	System wake-up period					
	Fast wake-up by IO toggle from STOPEXE suspend		128		T_{SYS}	Where T_{SYS} is the time period of system clock
	Fast wake-up by IO toggle from STOPSYS suspend, IHRC is the system clock		128 T_{SYS} + T_{SIHRC}			Where T_{SIHRC} is the stable time of IHRC from power-on. $T_{SIHRC} = 5\mu s @ VDD=5V$
	Fast wake-up by IO toggle from STOPSYS suspend, EOSC is the system clock		128 T_{SYS} + T_{SEOSC}			Where T_{SILRC} is the stable time of ILRC from power-on. $T_{SILRC} = 43ms @ VDD=5V$
	Normal wake-up from STOPEXE or STOPSYS suspend		1024		T_{ILRC}	Where T_{ILRC} is the clock period of ILRC
t_{RST}	External reset pulse width	120			us	@VDD=5V

*These parameters are for design reference, not tested for every chip.

** Under_20ms_Vdd_Ok is a checking condition for the VDD rising from 0V to the stated voltage within 20ms.

4.2. Absolute Maximum Ratings

- Supply Voltage 2.2V ~ 5.5V
- Input Voltage -0.3V ~ VDD + 0.3V
- Operating Temperature PMC271 series: -40°C ~ 85°C
PMS271 series: -20°C ~ 70°C
- Storage Temperature -50°C ~ 125°C

4.3. Typical IHRC Frequency vs. VDD (calibrated to 16MHz)

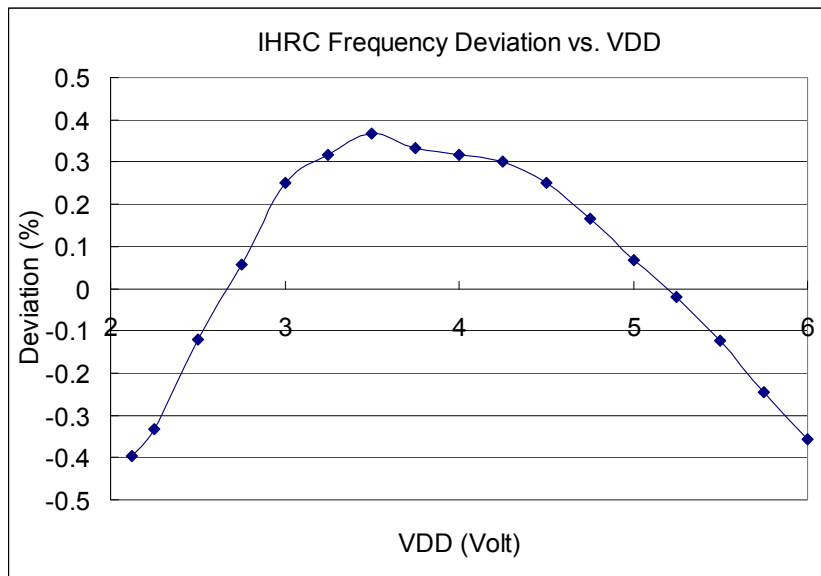

4.4. Typical ILRC Frequency vs. VDD

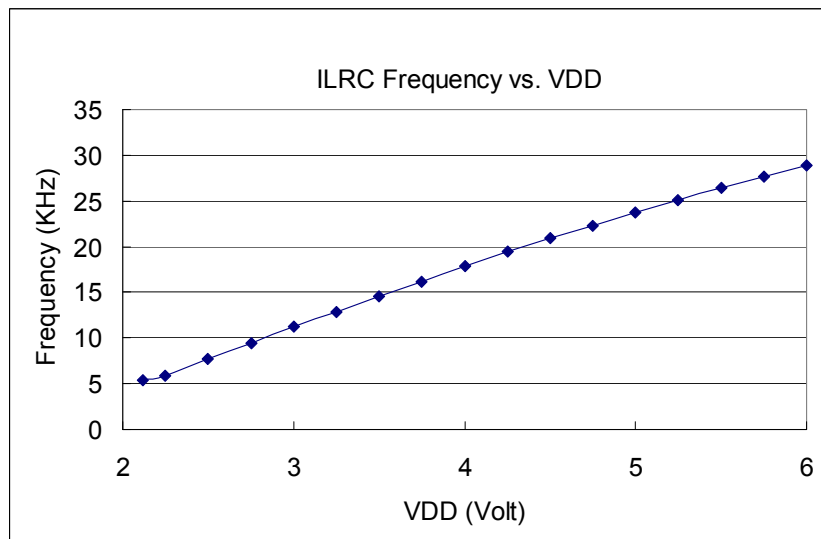

4.5. Typical IHRC Frequency vs. Temperature (calibrated to 16MHz)

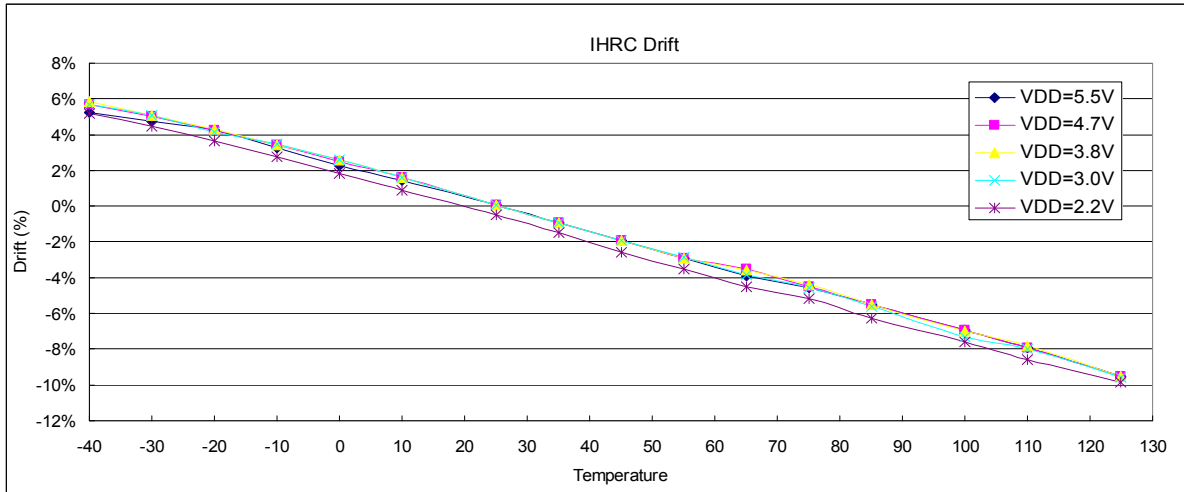

4.6. Typical ILRC Frequency vs. Temperature

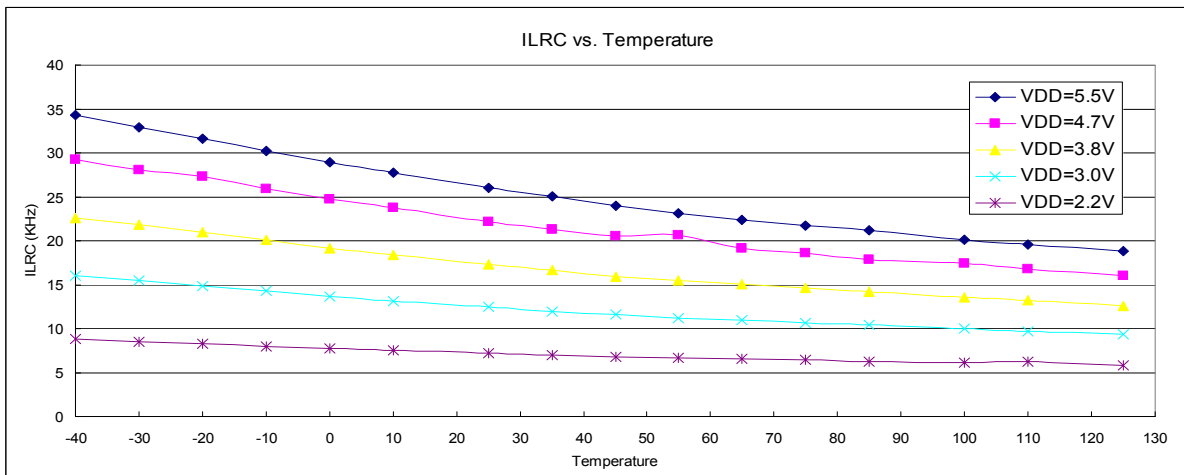

4.7. Typical Operating Current vs. VDD and CLK=IHRC/n

- Conditions: **ON**: Band-gap, LVR, IHRC modules; **OFF**: ADC, T16, ILRC, EOSC modules;
- IO**: PA0:0.5Hz output toggle and no loading, others: input and no floating

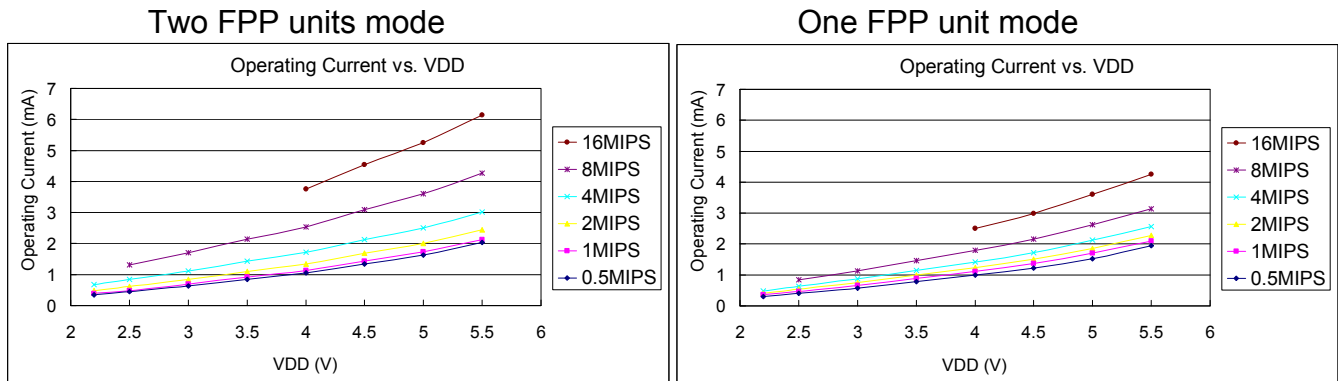

4.8. Typical Operating Current vs. VDD and CLK=ILRC/n

- Conditions: **ON**: Band-gap, LVR, ILRC modules; **OFF**: ADC, T16, IHRC, EOSC modules;
- IO**: PA0:0.5Hz output toggle and no loading, others: input and no floating

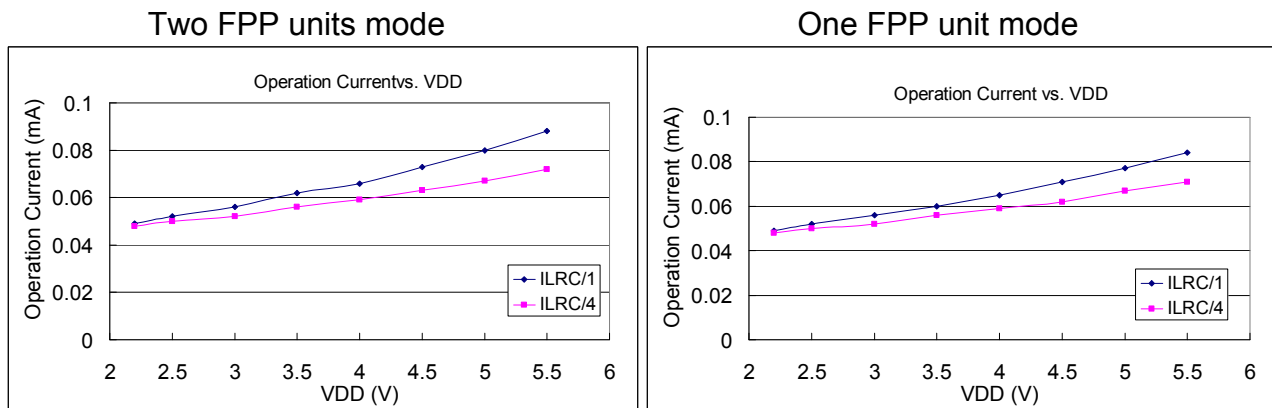

4.9. Typical Lowest Operating Current vs. VDD and CLK=ILRC/n

- Conditions: **ON**: ILRC module; **OFF**: ADC, T16, IHRC, Band-gap, LVR, EOSC modules;
IO: PA0:0.5Hz output toggle and no loading, others: input and no floating

Two FPP units mode

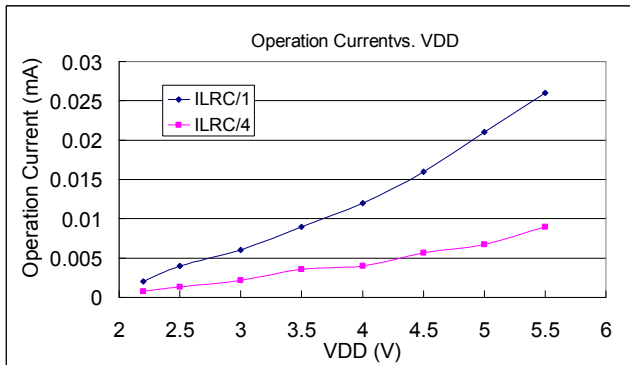

One FPP unit mode

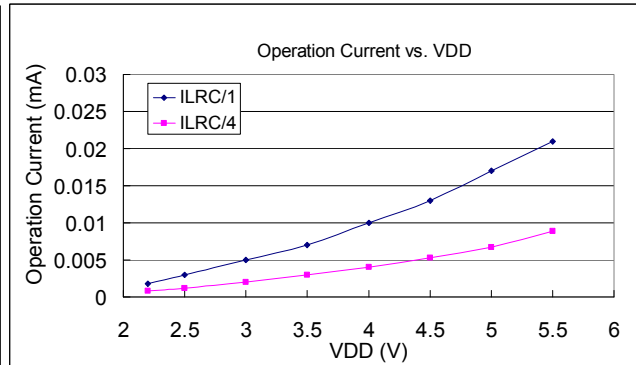

4.10. Typical Operating Current vs. VDD @CLK=32KHz EOSC/n

- Conditions: **ON**: EOSC, Band-gap, LVR modules; **OFF**: ADC, T16, IHRC, ILRC modules;
IO: PA0:0.5Hz output toggle and no loading, others: input and no floating
EOSC: High driving current

Two FPP units mode

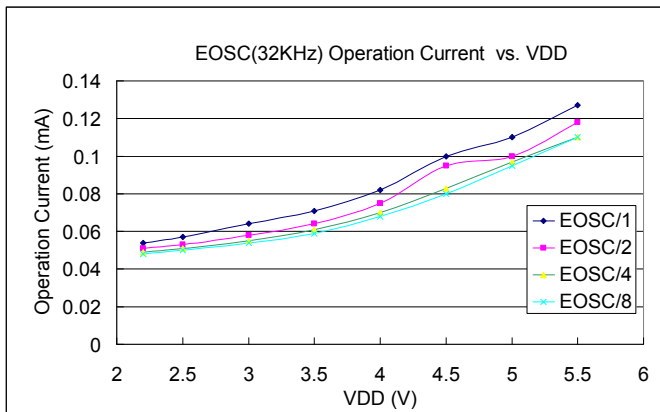

One FPP unit mode

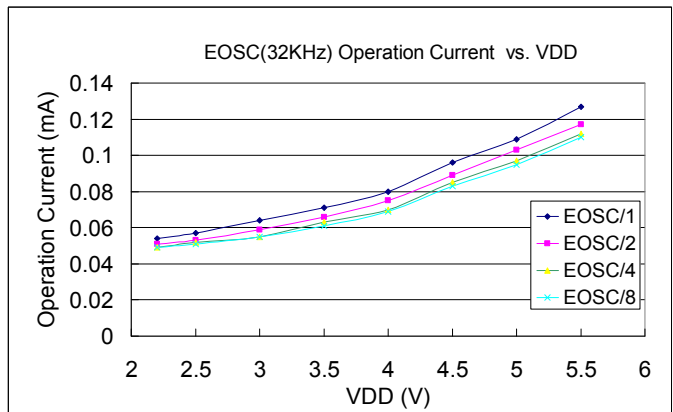

- Conditions: **ON**: **EOSC** module; **OFF**: ADC, T16, IHRC, ILRC, Band-gap, LVR modules;
IO: PA0:0.5Hz output toggle and no loading, others: input and no floating
EOSC: Low driving current

Two FPP units mode

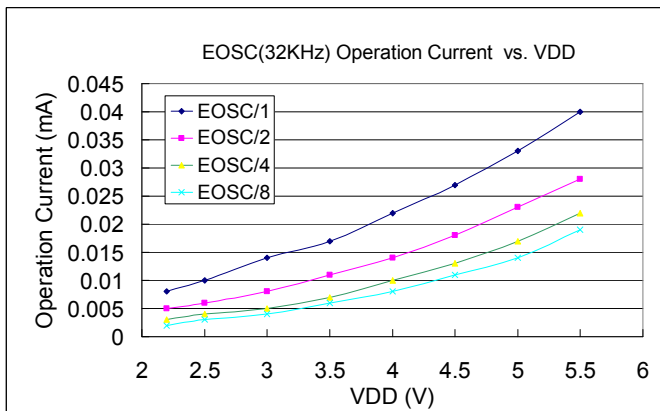

One FPP unit mode

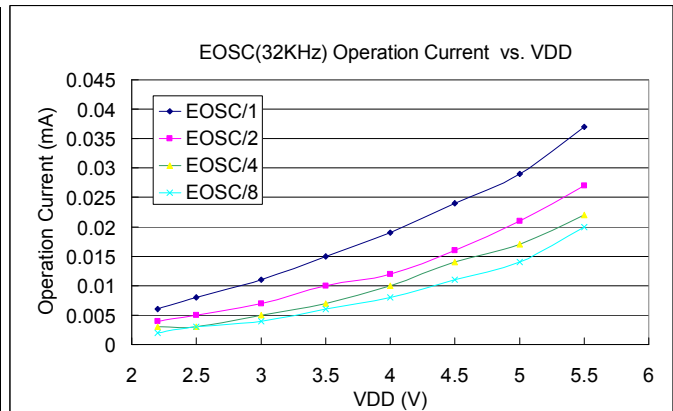

4.11. Typical Operating Current vs. VDD @CLK=1MHz EOSC/n

- Conditions: **ON**: EOSC, Band-gap, LVR modules; **OFF**: ADC, T16, IHRC, ILRC modules;
IO: PA0:0.5Hz output toggle and no loading, others: input and no floating
EOSC: High driving current

Two FPP units mode

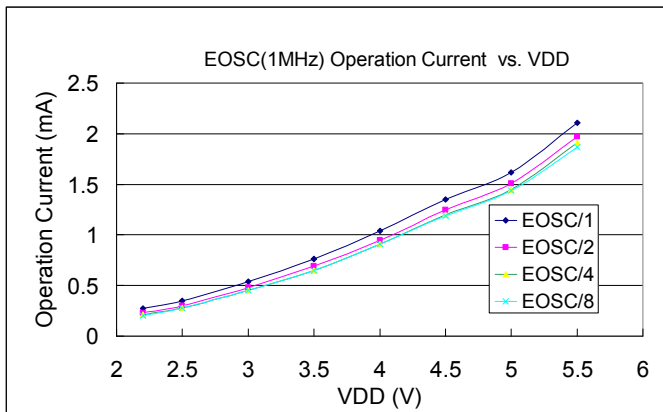

One FPP unit mode

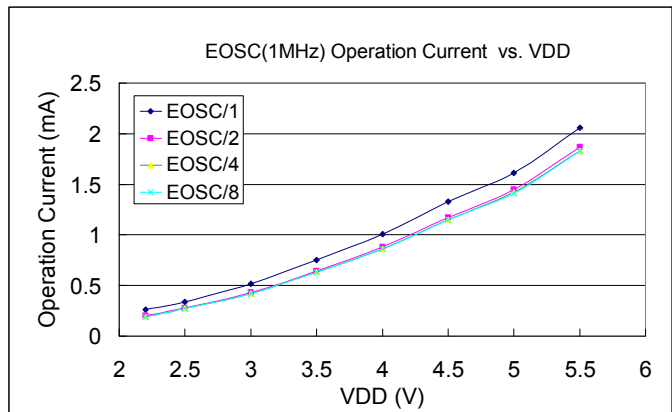

- Conditions: **ON**: EOSC module; **OFF**: ADC, T16, IHRC, ILRC, Band-gap, LVR modules;
IO: PA0:0.5Hz output toggle and no loading, others: input and no floating
EOSC: Low driving current

Two FPP units mode

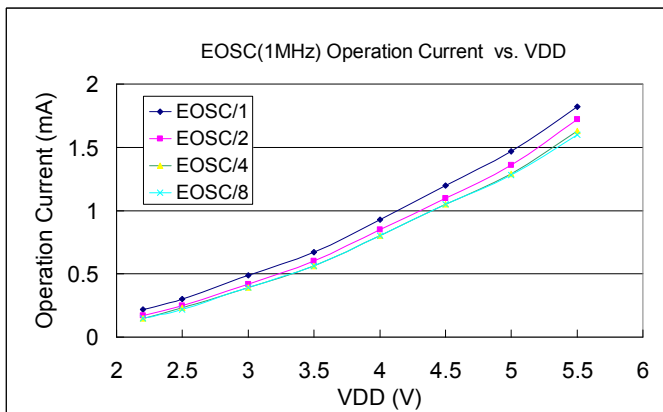

One FPP unit mode

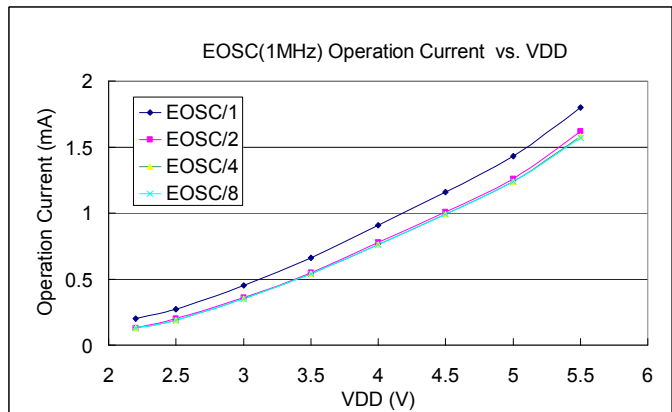

4.12. Typical Operating Current vs. VDD @CLK=4MHz EOSC/n

- Conditions: **ON**: EOSC, Band-gap, LVR modules; **OFF**: ADC, T16, IHRC, ILRC modules;
IO: PA0:0.5Hz output toggle and no loading, others: input and no floating
EOSC: High driving current

Two FPP units mode

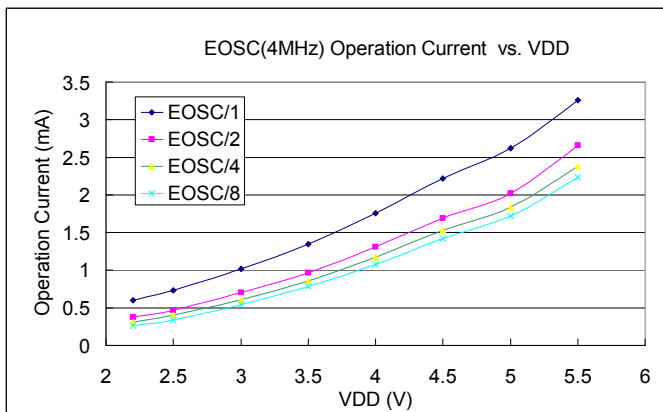

One FPP unit mode

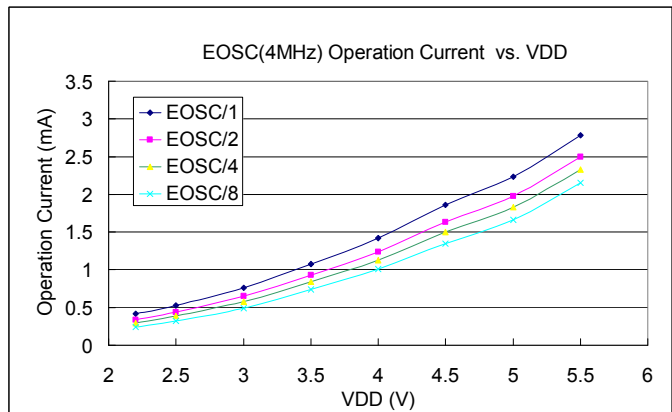

- Conditions: **ON**: EOSC module; **OFF**: ADC, T16, IHRC, ILRC, Band-gap, LVR modules;
IO: PA0:0.5Hz output toggle and no loading, others: input and no floating
EOSC: Low driving current

Two FPP units mode

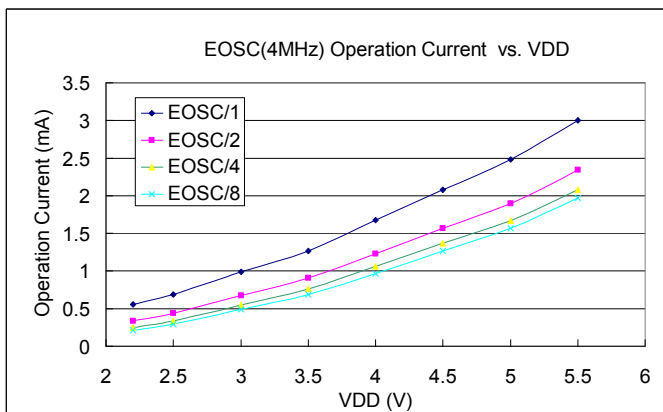

One FPP unit mode

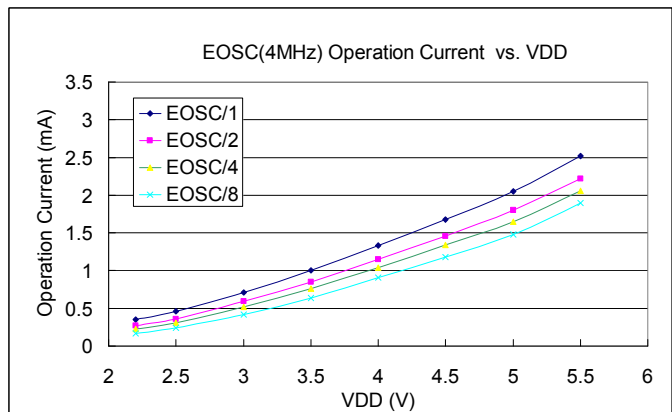

4.13. Typical IO pull high resistance

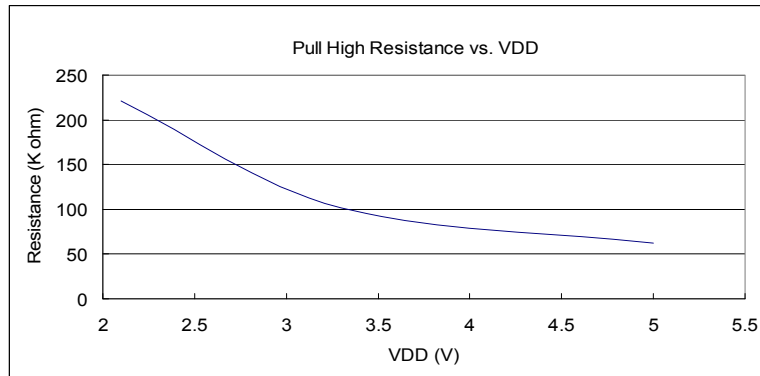

4.14. Typical IO driving current (I_{OH}) and sink current (I_{OL})

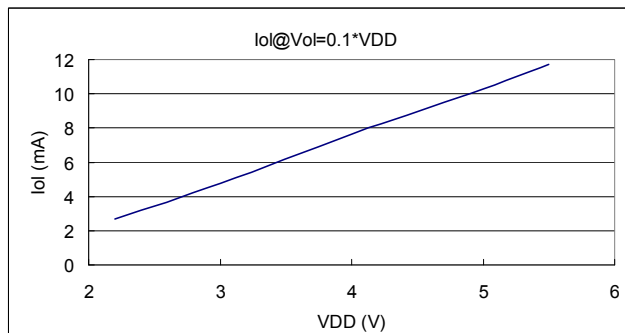
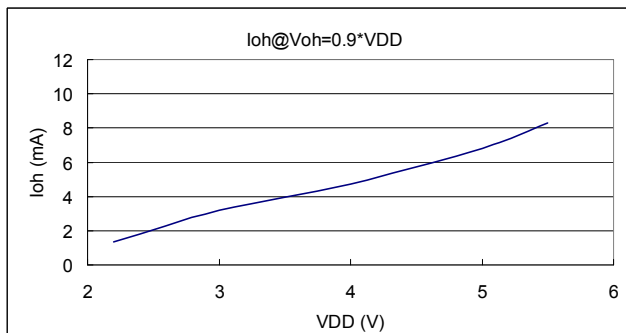

4.15. Typical IO input high / low threshold voltage (V_{IH}/V_{IL})

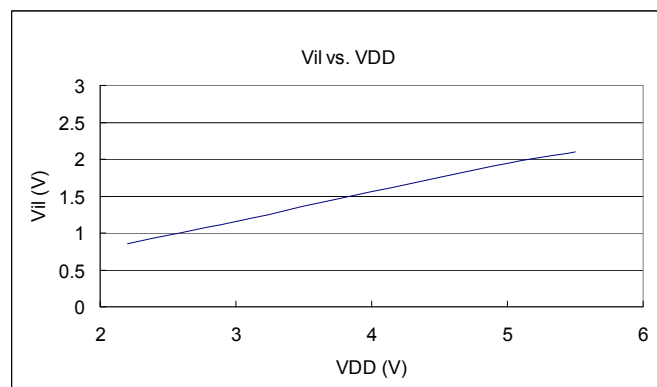
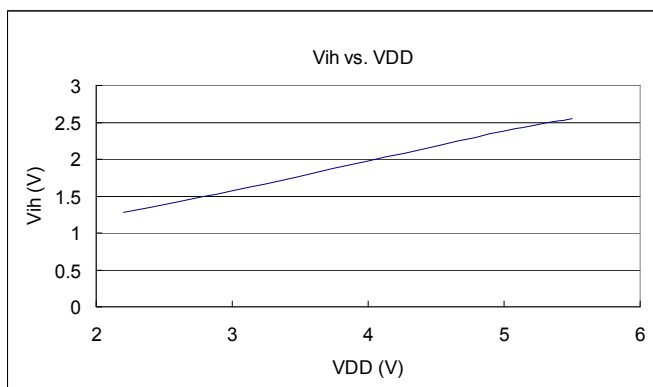

4.16. Typical (VDD/2) Bias output voltage

Output Voltage	VDD=5V	VDD=3.3V	VDD=2.1V
PA1	2.531V	1.667V	1.048V
PA2	2.531V	1.667V	1.049V
PA3	2.532V	1.667V	1.048V
PA4	2.531V	1.667V	1.047V

5. Functional Description

5.1. Processing Units

There are two processing units (FPP unit) inside the PMC271/PMS271. In each processing unit, it includes (i) its own Program Counter to control the program execution sequence (ii) its own Stack Pointer to store or restore the program counter for program execution (iii) its own accumulator (iv) Status Flag to record the status of program execution. Each FPP unit has its own program counter and accumulator for program execution, flag register to record the status, and stack pointer for jump operation. Based on such architecture, FPP unit can execute its own program independently, thus parallel processing can be expected.

These two FPP units share the same 1Kx16 bits OTP program memory, 64 bytes data SRAM and all the IO ports, these two FPP units are operated at mutual exclusive clock cycles to avoid interference. One task switch is built inside the chip to decide which FPP unit should be active for the corresponding cycle. The hardware diagram and basic timing diagram of FPP units are illustrated in Fig. 1. For FPP0 unit, its program will be executed in sequence every other system clock, shown as $(M-1)_{th}$, M_{th} and $(M+1)_{th}$ instructions. For FPP1 unit, its program will be also executed in sequence every other system clock, shown as $(N-1)_{th}$, N_{th} and $(N+1)_{th}$ instructions.

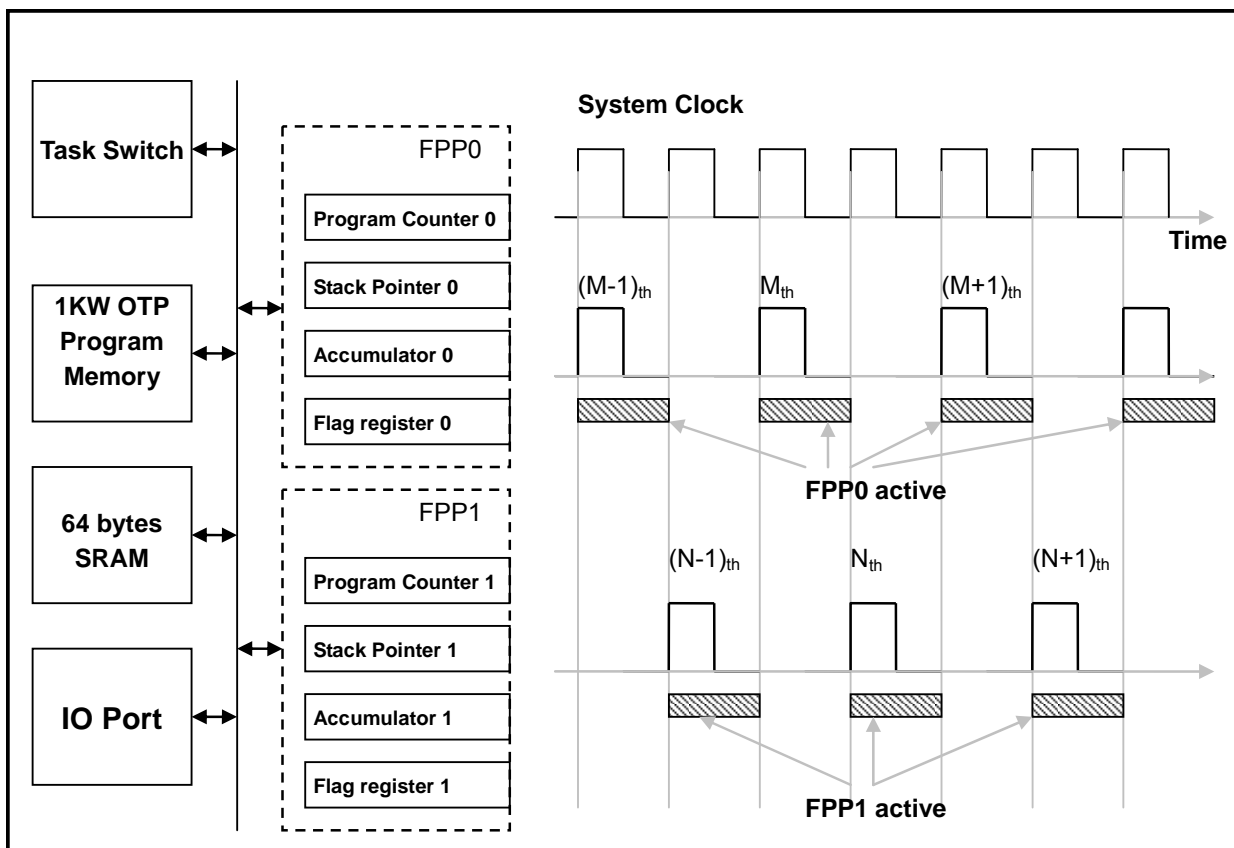

Fig. 1: Hardware and Timing Diagram of FPP units

Each FPP unit has half computing power of whole system; for example, FPP0 and FPP1 will be operated at 4MHz if system clock is 8MHz. The FPP unit can be enabled or disabled by programming the FPP unit Enable Register, only FPP0 is enabled after power-on reset. The system initialization will be started from FPP0 and FPP1 unit can be enabled by user's program if necessary. Both FPP0 and FPP1 can be enabled or disabled by using any one FPP unit.

5.1.1. Program Counter

Program Counter (PC) is the unit that contains the address of an instruction to be executed next. The program counter is automatically incremented at each instruction cycle so that instructions are retrieved sequentially from the program memory. Certain instructions, such as branches and subroutine calls, interrupt the sequence by placing a new value in the program counter. The bit length of the program counter is 10 for PMC271/PMS271. The initial program counter of FPP0 is 0 after hardware reset and 1 for FPP1. Whenever any interrupt happens, the program counter will jump to 'h10 for interrupt service routine, only FPP0 accept interrupt and each FPP unit has its own program counter to control the program execution sequence.

5.1.2. Stack Pointer

The stack pointer in each processing unit is used to point the top of the stack area where the local variables and parameters to subroutines are stored; the stack pointer register (**sp**) is located in IO address 0x02h. The stack pointer is 8 bit and so the stack memory cannot be accessed over 64 bytes and should be defined within 64 bytes from 0x00h address. The stack memory of PMC271/PMS271 for each FPP unit can be assigned by user via stack pointer register, means that the depth of stack pointer for each FPP unit is adjustable in order to optimize system performance. The following example shows how to define the stack in the ASM (assembly language) project:

```

    . ROMADR          0
    GOTO             FPPA0
    GOTO             FPPA1
    ...
    . RAMADR          0           // Address must be less than 0x100
    WORD             Stack0 [1]  // one WORD
    WORD             Stack1 [2]  // two WORD
    ...

FPPA0:
    SP = Stack0;           // assign Stack0 for FPPA0, one level call because of Stack0[1]
    ...
    call function1
    ...

FPPA1:
    SP = Stack1;           // assign Stack1 for FPPA1, two level call because of Stack1[2]
    ...
    call function2
    ...

```

In Mini-C project, the stack calculation is done by system software, user will not have effort on it, and the example is shown as below:

```

void FPPA0 (void)
{
...
}

```

User can check the stack assignment in the window of program disassembling, Fig. 2 shows that the status of stack before FPP0 execution, system has calculated the required stack space and has reserved for the program.

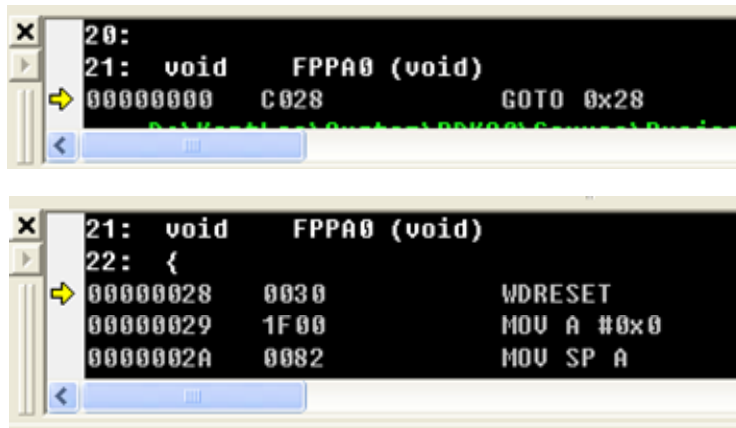

```

20: void FPPA0 (void)
00000000 C028 GOTO 0x28

21: void FPPA0 (void)
22: {
00000028 0030 WRESET
00000029 1F00 MOU A #0x0
0000002A 0082 MOU SP A
  
```

Fig. 2: Stack Assignment in Mini-C project

5.1.3. Single FPP mode

For traditional MCU user who does not need parallel processing capability, PMC271/PMS271 provides single FPP mode optional to behave as traditional MCU. After single FPP mode is selected, FPP1 is always disabled and only FPP0 is active. Fig.3 shows the timing diagram for each FPP unit, FPP1 is always disabled and only FPP0 active. Please notice that wait and delay instructions are NOT supported when single FPP mode is chosen.

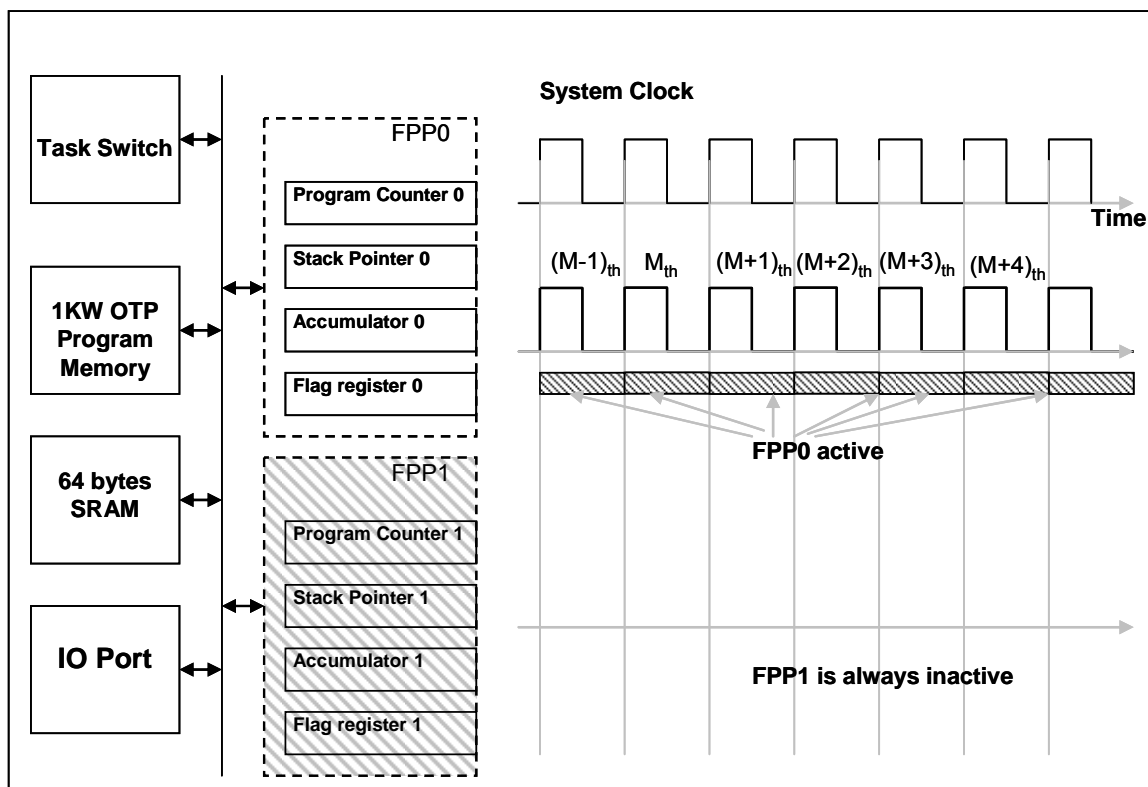

Fig. 3: Timing Diagram of single FPP mode

5.2. Program Memory – OTP

5.2.1. Program Memory Assignment

The OTP (One Time Programmable) program memory is used to store the program instructions to be executed. All program codes for each FPP unit are stored in this OTP memory for both FPP0 and FPP1. The OTP program memory may contains the data, tables and interrupt entry. After reset, the initial address for FPP0 is 'h0 and 'h1 for FPP1. The interrupt entry is 'h10 if used and interrupt function is for FPP0 only, the last eight addresses are reserved for system using, like checksum, serial number, etc. The OTP program memory for PMC271/PMS271 is a 1Kx16 bit that is partitioned as Table 1. The OTP memory from address 'h3F8 to 'h3FF is for system using, address space from 'h002 to 'h00F and from 'h011 to 'h3F7 are user program space. The address 'h001 is the FPP1 initial address for two FPP units mode and user program for single FPP unit mode.

Address	Function
'h000	FPP0 reset – goto instruction
'h001	FPP1 reset – goto instruction
'h002	User program
•	•
'h00F	User program
'h010	Interrupt entry address
'h011	User program
•	•
'h3F7	User program
'h3F8	System Using
•	•
'h3FF	System Using

Table 1: Program Memory Organization of PMC271/PMS271

5.2.2. Example of Using Program Memory for Two FPP mode

Table 2 shows one example of using program memory which two FPP units are active.

Address	Function
000	FPP0 reset – goto instruction (goto 'h020)
001	Begin of FPP1 program
•	•
00F	goto 'h1A1 to continue FPP1 program
010	Interrupt entry address (FPP0 only)
•	•
01F	End of ISR
020	Begin of FPP0 user program
•	•
1A0	End of FPP0 user program
1A1	Continuing FPP1 program
•	•
3F7	End of FPP1 program
3F8	System Using
•	•
3FF	System Using

Table 2: Example of using Program Memory for two FPP units mode

5.2.3. Example of Using Program Memory for Single FPP mode

The entire user's program memory can be assigned to FPP0 when single FPP mode is selected. Table 3 shows the example of program memory using for single FPP unit mode.

Address	Function
000	FPP0 reset
001	Begin of user program
002	user program
•	•
00F	goto instruction (goto 'h020)
010	Interrupt entry address
011	ISR
•	•
01F	End of ISR
020	user program
•	•
•	•
3F7	user program
3F8	System Using
•	•
3FF	System Using

Table 3: Example of using Program Memory for single FPP mode

5.3. Program Structure

5.3.1. Program structure of two FPP units mode

After power-up, the program starting address of FPP0 is 0x000 and 0x001 for FPP1. The 0x010 is the entry address of interrupt service routine, which belongs to FPP0 only. The basic firmware structure for PMC271/PMS271 is shown as Fig. 4, the program codes of two FPP units are placed in one whole program space. Except for the initial addresses of processing units and entry address of interrupt, the memory location is not specially specified; the program codes of processing unit can be resided at any location no matter what the processing unit is. After power-up, the fpp0Boot will be executed first, which will include the system initialization and other FPP units enabled.

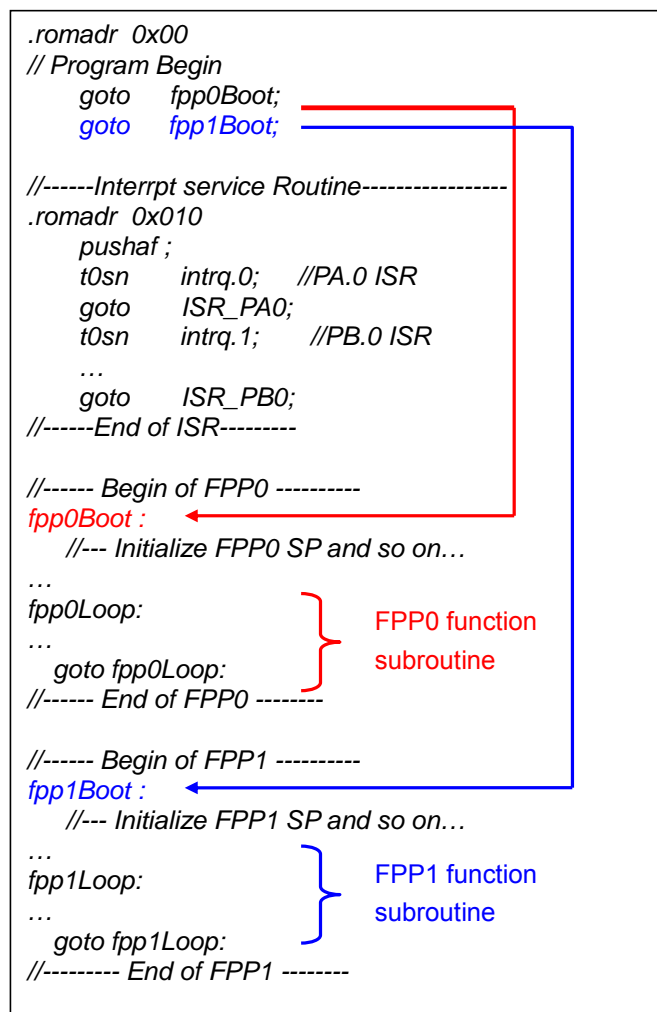

Fig. 4: Program Structure of two FPP units mode

5.3.2. Program structure of single FPP mode

After power-up, the program starting address of FPP0 is 0x000, 0x010 is the entry address of interrupt service routine. For single FPP unit mode, the firmware structure is same as traditional MCU. After power-up, the program will be executed from address 0x000, then continuing the program sequence.

5.4. Boot Procedure

POR (Power-On-Reset) is used to reset PMC271/PMS271 when power up, however, the supply voltage may be not stable. To ensure the stability of supply voltage after power up, it will wait 1024 ILRC clock cycles before first instruction being executed, which is t_{SBP} and shown in the Fig. 5.

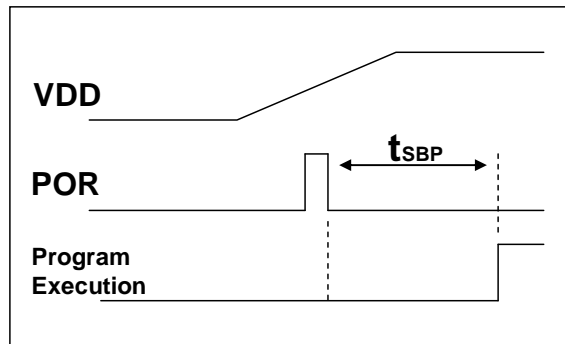

Boot up from Power-On Reset

Fig. 5: Power Up Sequence

Fig. 6 shows the typical program flow after boot up. Please notice that the FPP1 is disabled after reset and recommend NOT enabling FPP1 before system and FPP0 initialization.

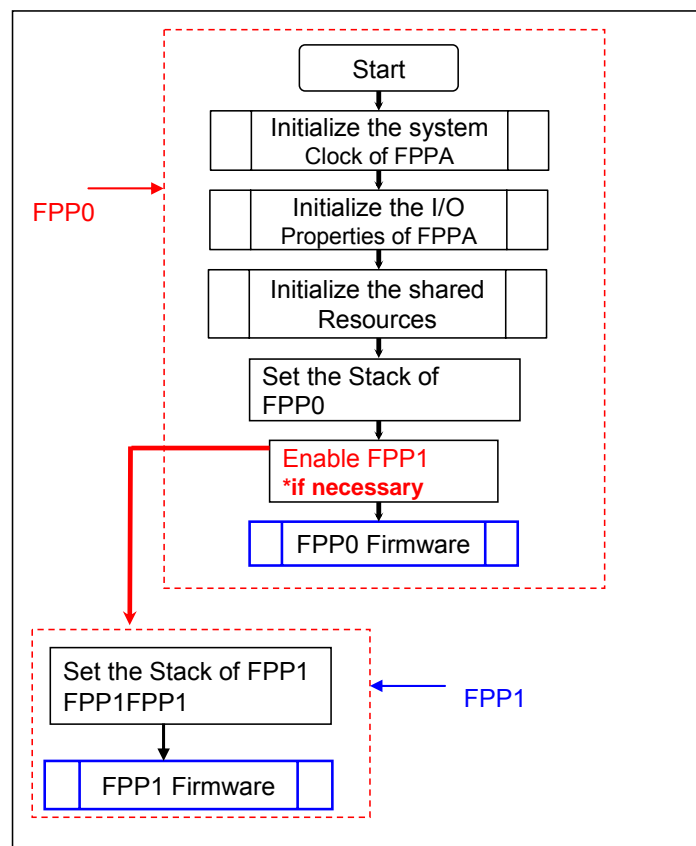

Fig. 6: Boot Procedure

5.5. Data Memory – SRAM

Fig. 7 shows the SRAM data memory organization of PMC271/PMS271, all the SRAM data memory could be accessed by FPP0 and FPP1 directly with 1T clock cycle, the data access can be byte or bit operation. Besides data storage, the SRAM data memory is also served as data pointer of indirect access method and the stack memory for all FPP units.

The stack memory for each processing unit should be independent from each other, and defined in the data memory. The stack pointer is defined in the stack pointer register of each processing unit; the depth of stack memory of each processing unit is defined by the user. The arrangement of stack memory fully flexible and can be dynamically adjusted by the user.

For indirect memory access mechanism, the data memory is used as the data pointer to address the data byte. All the data memory could be the data pointer; it's quite flexible and useful to do the indirect memory access. Since the data width is 8-bit, the memory size of indirect memory access is only 256 bytes only, all the 64 bytes data memory of PMC271/PMS271 can be accessed by indirect access mechanism.

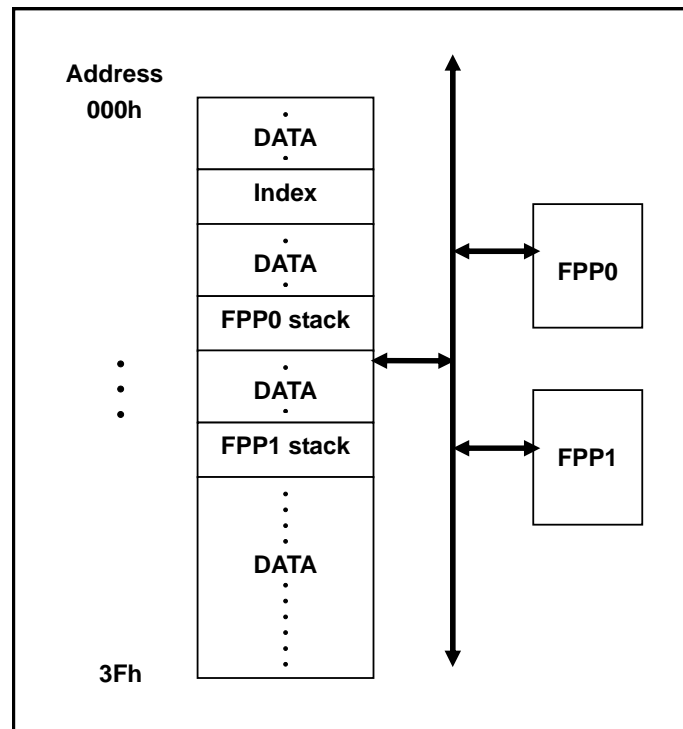

Fig. 7: Data Memory Organization

5.6. Arithmetic and Logic Unit

Arithmetic and Logic Unit (ALU) is the computation element to operate integer arithmetic, logic, shift and other specialized operations. The operation data can be from instruction, accumulator or SRAM data memory. Computation result could be written into accumulator or SRAM. FPP0 and FPP1 will share ALU for its corresponding operation.

5.7. Oscillator and clock

There are three oscillator circuits provided by PMC271/PMS271: external crystal oscillator (EOSC), internal high RC oscillator (IHRC) and internal low RC oscillator (ILRC), and these three oscillators are enabled or disabled by registers `eoscr.7`, `clkmd.4` and `clkmd.2` independently. User can choose one of these three oscillators as system clock source and use ***clkmd*** register to target the desired frequency as system clock to meet different application.

Oscillator Module	Enable/Disable	Default after boot-up
EOSC	<code>eoscr.7</code>	Disabled
IHRC	<code>clkmd.4</code>	Enabled
ILRC	<code>clkmd.2</code>	Enabled

5.7.1. Internal High RC oscillator and Internal Low RC oscillator

After boot-up, the IHRC and ILRC oscillators are enabled. The frequency of IHRC can be calibrated to eliminate process variation by ***ihrcr*** register; normally it is calibrated to 16MHz. The frequency deviation can be within 2% normally after calibration and it still drifts slightly with supply voltage and operating temperature, the total drift rate is about $\pm 6\%$ for $VDD=2.2V\sim 5.5V$ and $-40^{\circ}C\sim 85^{\circ}C$ operating conditions. Please refer to the measurement chart for IHRC frequency verse VDD and IHRC frequency verse temperature. The frequency of ILRC is around 21 KHz, however, its frequency will vary by process, supply voltage and temperature, please refer to DC specification and do not use for accurate timing application.

5.7.2. Chip calibration

The IHRC frequency and band-gap reference voltage may be different chip by chip due to manufacturing variation, PMC271/PMS271 provide both the IHRC frequency calibration and band-gap calibration to eliminate this variation, and this function can be selected when compiling user's program and the command will be inserted into user's program automatically. The calibration command is shown as below:

```
.ADJUST_IC SYSCLK=IHRC/(p1), IHRC=(p2)MHz, VDD=(p3)V, Band-gap=(p4);
```

Where,

p1=2, 4, 8, 16, 32; In order to provide different system clock.

p2=16 ~ 18; In order to calibrate the chip to different frequency, 16MHz is the usually one.

p3=2.5 ~ 5.5; In order to calibrate the chip under different supply voltage.

p4= On or Off; Band-gap calibration is On or Off.

5.7.3. IHRC Frequency Calibration and System Clock

During compiling the user program, the options for IHRC calibration and system clock are shown as Table 4:

SYSCLK	CLKMD	IHRCR	Description
o Set IHRC / 2	= 34h (IHRC / 2)	Calibrated	IHRC calibrated to 16MHz, CLK=8MHz (IHRC/2)
o Set IHRC / 4	= 14h (IHRC / 4)	Calibrated	IHRC calibrated to 16MHz, CLK=4MHz (IHRC/4)
o Set IHRC / 8	= 3Ch (IHRC / 8)	Calibrated	IHRC calibrated to 16MHz, CLK=2MHz (IHRC/8)
o Set IHRC / 16	= 1Ch (IHRC / 16)	Calibrated	IHRC calibrated to 16MHz, CLK=1MHz (IHRC/16)
o Set IHRC / 32	= 7Ch (IHRC / 32)	Calibrated	IHRC calibrated to 16MHz, CLK=0.5MHz (IHRC/32)
o Set ILRC	= E4h (ILRC / 1)	Calibrated	IHRC calibrated to 16MHz, CLK=ILRC
o Disable	No change	No Change	IHRC not calibrated, CLK not changed, Band-gap OFF

Table 4: Options for IHRC Frequency Calibration

Usually, .ADJUST_IC will be the first command after boot up, in order to set the target operating frequency whenever starting the system. The program code for IHRC frequency calibration is executed only one time that occurs in writing the codes into OTP memory; after then, it will not be executed again. If the different option for IHRC calibration is chosen, the system status is also different after boot. The following shows the status of PMC271/PMS271 for different option:

- (1)** .ADJUST_IC SYSCLK=IHRC/2, IHRC=16MHz, VDD=5V, Band-gap=On
After boot up, CLKMD = 0x34:

 - ◆ IHRC frequency is calibrated to 16MHz@VDD=5V and IHRC module is enabled
 - ◆ System CLK = IHRC/2 = 8MHz
 - ◆ Watchdog timer is disabled, ILRC is enabled, PA5 is in input mode, BG=1.2V

- (2)** .ADJUST_IC SYSCLK=IHRC/4, IHRC=16MHz, VDD=3.3V, Band-gap=On
After boot up, CLKMD = 0x14:

 - ◆ IHRC frequency is calibrated to 16MHz@VDD=3.3V and IHRC module is enabled
 - ◆ System CLK = IHRC/4 = 4MHz
 - ◆ Watchdog timer is disabled, ILRC is enabled, PA5 is in input mode, BG=1.2V

- (3)** .ADJUST_IC SYSCLK=IHRC/8, IHRC=16MHz, VDD=2.5V, Band-gap=On
After boot up, CLKMD = 0x3C:

 - ◆ IHRC frequency is calibrated to 16MHz@VDD=2.5V and IHRC module is enabled
 - ◆ System CLK = IHRC/8 = 2MHz
 - ◆ Watchdog timer is disabled, ILRC is enabled, PA5 is in input mode, BG=1.2V

- (4)** .ADJUST_IC SYSCLK=IHRC/16, IHRC=16MHz, VDD=2.5V, Band-gap=On
After boot up, CLKMD = 0x1C:

 - ◆ IHRC frequency is calibrated to 16MHz@VDD=2.5V and IHRC module is enabled
 - ◆ System CLK = IHRC/16 = 1MHz
 - ◆ Watchdog timer is disabled, ILRC is enabled, PA5 is in input mode, BG=1.2V

- (5)** .ADJUST_IC SYSCLK=IHRC/32, IHRC=16MHz, VDD=5V, Band-gap=Off
After boot up, CLKMD = 0x7C:

 - ◆ IHRC frequency is calibrated to 16MHz@VDD=5V and IHRC module is enabled
 - ◆ System CLK = IHRC/32 = 500KHz
 - ◆ Watchdog timer is disabled, ILRC is enabled, PA5 is in input mode

- (6)** .ADJUST_IC SYSCLK=ILRC, IHRC=16MHz, VDD=5V, Band-gap=Off
After boot up, CLKMD = 0XE4:

 - ◆ IHRC frequency is calibrated to 16MHz@VDD=5V and IHRC module is disabled
 - ◆ System CLK = ILRC
 - ◆ Watchdog timer is disabled, ILRC is enabled, PA5 is input mode

- (7)** .ADJUST_IC DISABLE
After boot up, CLKMD is not changed (Do nothing):

 - ◆ IHRC is not calibrated and IHRC module is disabled. Band-gap is not calibrated
 - ◆ System CLK = ILRC
 - ◆ Watchdog timer is enabled, ILRC is enabled, PA5 is in input mode

5.7.4. External Crystal Oscillator

If crystal oscillator is used, a crystal or resonator is required between X1 and X2. Fig. 8 shows the hardware connection under this application; the range of operating frequency of crystal oscillator can be from 32 KHz to 4MHz, depending on the crystal placed on; higher frequency oscillator than 4MHz is NOT supported.

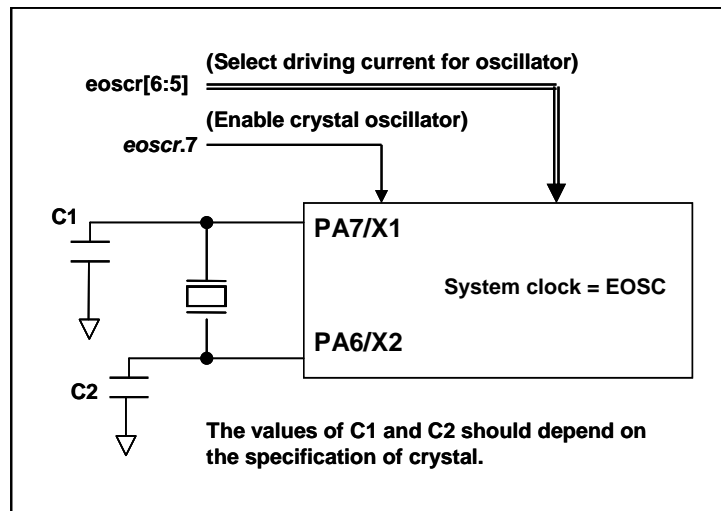

Fig. 8: Connection of crystal oscillator

Besides crystal, external capacitor and options of PMC271/PMS271 should be fine tuned in *eoscr* (0x0b) register to have good sinusoidal waveform. The *eoscr.7* is used to enable crystal oscillator module, *eoscr.6* and *eoscr.5* are used to set the different driving current to meet the requirement of different frequency of crystal oscillator:

- ◆ *eoscr*[6:5]=01 : Low driving capability, for lower frequency, ex: 32KHz crystal oscillator
- ◆ *eoscr*[6:5]=10 : Middle driving capability, for middle frequency, ex: 1MHz crystal oscillator
- ◆ *eoscr*[6:5]=11 : High driving capability, for higher frequency, ex: 4MHz crystal oscillator

Table 5 shows the recommended values of C1 and C2 for different crystal oscillator; the measured start-up time under its corresponding conditions is also shown. Since the crystal or resonator had its own characteristic, the capacitors and start-up time may be slightly different for different type of crystal or resonator, please refer to its specification for proper values of C1 and C2.

Frequency	C1	C2	Measured Start-up time	Conditions
4MHz	4.7pF	4.7pF	6ms	(<i>eoscr</i> [6:5]=11, <i>misc.6</i> =0)
1MHz	10pF	10pF	11ms	(<i>eoscr</i> [6:5]=10, <i>misc.6</i> =0)
32KHz	22pF	22pF	450ms	(<i>eoscr</i> [6:5]=01, <i>misc.6</i> =0)

Table 5: Recommend values of C1 and C2 for crystal and resonator oscillators

When using the crystal oscillator, user must pay attention to the stable time of oscillator after enabling it, the stable time of oscillator will depend on frequency ` crystal type ` external capacitor and supply voltage. Before switching the system to the crystal oscillator, user must make sure the oscillator is stable; the reference program is shown as below:

```

void  FPPA0 (void)
{
    .ADJUST_IC  SYSCLK=IHRC/16, IHRC=16MHz, VDD=5V, Band-gap=On
    // You can write here '.ADJUST_IC DISABLE ' for band-gap off
    ...
    $  EOSCR    Enable, 4Mhz;           // EOSCR = 0b110_00000;
    $  T16M     EOSC, /1, BIT13;       // T16 receive 2^14=16384 clocks
                                        // of crystal osc.,
                                        // Intrq.T16 =>1, crystal osc. Is stable

    WORD      count = 0;
    stt16     count;
    Intrq.T16 = 0;
    wait1     Intrq.T16;               // count fm 0x0000 to 0x2000,
                                        // then setINTRQ.T16

    clkmd     = 0xA4;                 // switch system clock to EOSC;
    ...
}

```

Please notice that the crystal oscillator should be fully turned off before entering the power-down mode, in order to avoid unexpected wakeup event. If the 32KHz crystal oscillator is used and extremely low operating current is required, *misc.6* can be set to reduce current after crystal oscillator is running normally.

5.7.5. System Clock and LVR levels

The clock source of system clock comes from EOSC, IHRC and ILRC, the hardware diagram of system clock in the PMC271/PMS271 is shown as Fig. 9.

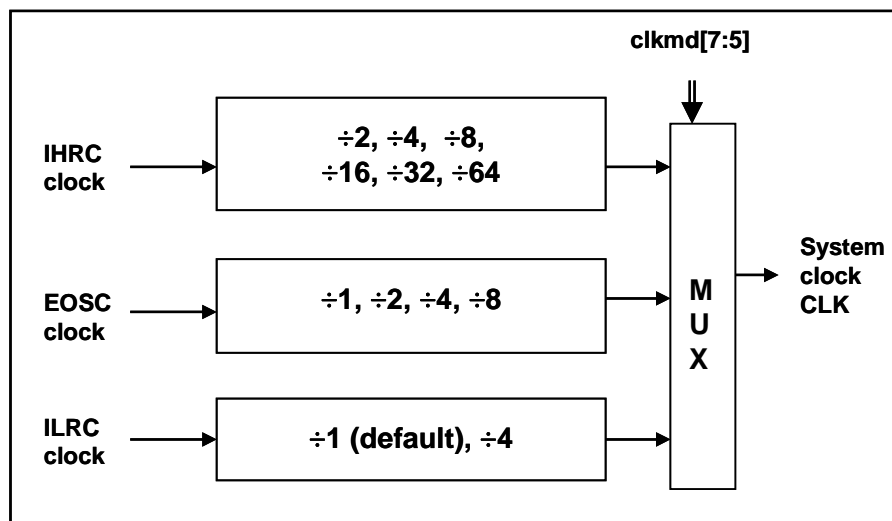

Fig. 9: Options of System Clock

User can choose different operating system clock depends on its requirement; the selected operating system clock should be combined with supply voltage and LVR level to make system stable. The LVR level will be selected during compilation, the following operating frequency and LVR level is recommended:

- ◆ system clock = 8MHz with LVR=3.1V
- ◆ system clock = 4MHz with LVR=2.5V
- ◆ system clock = 2MHz with LVR=2.2V

5.7.6. System Clock Switching

After IHRC calibration, user may want to switch system clock to a new frequency or may switch system clock at any time to optimize the system performance and power consumption. Basically, the system clock of PMC271/PMS271 can be switched among IHRC, ILRC and EOSC by setting the **clkmd** register at any time; system clock will be the new one after writing to **clkmd** register immediately. Please notice that the original clock module can NOT be turned off at the same time as writing command to **clkmd** register. The examples are shown as below and more information about clock switching, please refer to the “Help → Application Note → IC Introduction → Register Introduction → CLKMD”.

Case 1: Switching system clock from ILRC to IHRC/2

```

...                                     // system clock is ILRC
CLKMD                                = 0x34 ; // switch to IHRC/2 · ILRC CAN NOT be disabled here
CLKMD.2                              = 0 ;   // ILRC CAN be disabled at this time
...

```

Case 2: Switching system clock from ILRC to EOSC

```

...                                     // system clock is ILRC
CLKMD                                = xA6 ; // switch to IHRC · ILRC CAN NOT be disabled here
CLKMD.2                              = 0 ;   // ILRC CAN be disabled at this time
...

```

Case 3: Switching system clock from IHRC/2 to ILRC

```

...                                     // system clock is IHRC/2
CLKMD                                = 0xF4 ; // switch to ILRC · IHRC CAN NOT be disabled here
CLKMD.4                              = 0 ;   // IHRC CAN be disabled at this time
...

```

Case 4: Switching system clock from IHRC/2 to EOSC

```

...                                     // system clock is IHRC/2
CLKMD                                = 0xB0 ; // switch to EOSC · IHRC CAN NOT be disabled here
CLKMD.4                              = 0 ;   // IHRC CAN be disabled at this time
...

```

Case 5: Switching system clock from IHRC/2 to IHRC/4

```

...                                     // system clock is IHRC/2, ILRC is enabled here
CLKMD                                = 0X14 ; // switch to IHRC/4
...

```

Case 6: System may hang if it is to switch clock and turn off original oscillator at the same time

```

...                                     // system clock is ILRC
CLKMD                                = 0x30 ; // CAN NOT switch clock from ILRC to IHRC/2 and
                                                // turn off ILRC oscillator at the same time

```

5.8. 16-bit Timer (Timer16)

PMC271/PMS271 provides a 16-bit hardware timer (Timer16) and its clock source may come from system clock (CLK), external crystal oscillator (EOSC), internal high RC oscillator (IHRC), internal low RC oscillator (ILRC), PA0 or PA4. Before sending clock to the 16-bit counter, a pre-scaling logic with divided-by-1, 4, 16 or 64 is selectable for wide range counting. The 16-bit counter performs up-counting operation only, the counter initial values can be stored from data memory by issuing the *stt16* instruction and the counting values can be loaded to data memory by issuing the *ldt16* instruction. The interrupt request from Timer16 will be triggered by the selected bit which comes from bit[15:8] of this 16-bit counter, rising edge or falling edge can be optional chosen by register *integs.4*. The hardware diagram of Timer16 is shown as Fig. 10.

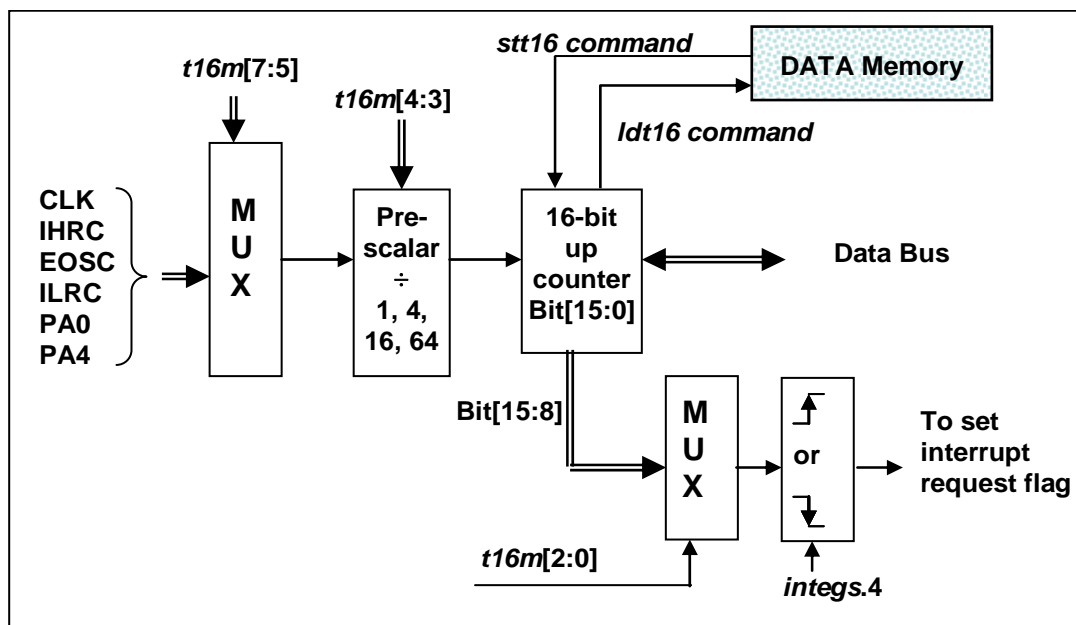

Fig. 10: Hardware diagram of Timer16

When using the Timer16, the syntax for Timer16 has been defined in the .INC file. There are three parameters to define the Timer16 using; 1st parameter is used to define the clock source of Timer16, 2nd parameter is used to define the pre-scaler and the 3rd one is to define the interrupt source.

```

T16M  IO_RW  0x06
$ 7~5:  STOP, SYSCLK, X, X, IHRC, EOSC, ILRC, PA0           // 1st par.
$ 4~3:  /1, /4, /16, /64                                     // 2nd par.
$ 2~0:  BIT8, BIT9, BIT10, BIT11, BIT12, BIT13, BIT14, BIT15 // 3rd par.

```

User can choose the proper parameters of T16M to meet system requirement, examples as below:

```

$  T16M  SYSCLK, /64, BIT15;
// choose (SYSCLK/64) as clock source, every 2^16 clock to set INTRQ.2=1
// if system clock SYSCLK = IHRC / 2 = 8 MHz
// SYSCLK/64 = 8 MHz/64 = 8 uS, about every 524 mS to generate INTRQ.2=1

```

```

$ T16M EOSC, /1, BIT13;
// choose (EOSC/1) as clock source, every 2^14 clock cycle to generate INTRQ.2=1
// if EOSC=32768 Hz, 32768 Hz/(2^14) = 2Hz, every 0.5S to generate INTRQ.2=1

$ T16M PA0, /1, BIT8;
// choose PA0 as clock source, every 2^9 to generate INTRQ.2=1
// receiving every 512 times PA0 to generate INTRQ.2=1

$ T16M STOP;
// stop Timer16 counting

```

5.9. Watchdog Timer

The watchdog timer (WDT) is a counter with clock coming from ILRC and its frequency is about 24 KHz.

There are four different timeout periods of watchdog timer can be chosen by setting the *misc* register, it is:

- ◆ 256 ILRC period when misc[1:0]=11
- ◆ 16384 ILRC period when misc[1:0]=10
- ◆ 4096 ILRC period when misc[1:0]=01
- ◆ 2048 ILRC period when misc[1:0]=00 (default)

The frequency of ILRC may drift a lot due to the variation of manufacture, supply voltage and temperature; user should reserve guard band for save operation. WDT can be cleared by power-on-reset or by command **wdreset** at any time. When WDT is timeout, PMC271/PMS271 will be reset to restart the program execution. The relative timing diagram of watchdog timer is shown as Fig. 11. Please notice that the clock source will be switched to system clock (for example: 4MHz) when fast wakeup is enabled, therefore, it is recommended to turn off the watchdog timer **before** enabling the fast wakeup and turn on the watchdog timer **after** disabling the fast wakeup.

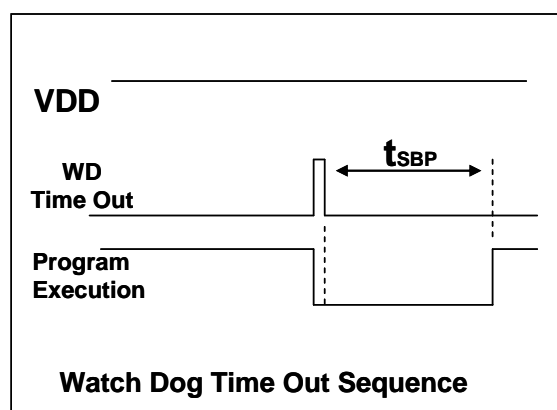

Fig. 11: Sequence of Watch Dog Time Out

5.10. Interrupt

There are four interrupt lines for PMC271/PMS271:

- ◆ External interrupt PA0
- ◆ External interrupt PB0
- ◆ ADC interrupt
- ◆ Timer16 interrupt

Every interrupt request line has its own corresponding interrupt control bit to enable or disable it; the hardware diagram of interrupt function is shown as Fig. 12. All the interrupt request flags are set by hardware and cleared by writing *intrq* register. When the request flags are set, it can be rising edge, falling edge or both, depending on the setting of register *integs*. All the interrupt request lines are also controlled by *engint* instruction (enable global interrupt) to enable interrupt operation and *disgint* instruction (disable global interrupt) to disable it. Only FPP0 can accept the interrupt request, other FPP unit will not be interfered by interrupt. The stack memory for interrupt is shared with data memory and its address is specified by stack register *sp*. Since the program counter is 16 bits width, the bit 0 of stack register *sp* should be kept 0. Moreover, user can use *pushaf* / *popaf* instructions to store or restore the values of *ACC* and *flag* register *to* / *from* stack memory.

Since the stack memory is shared with data memory, user should manipulate the memory using carefully. By adjusting the memory location of stack point, the depth of stack pointer for every FPP unit could be fully specified by user to achieve maximum flexibility of system.

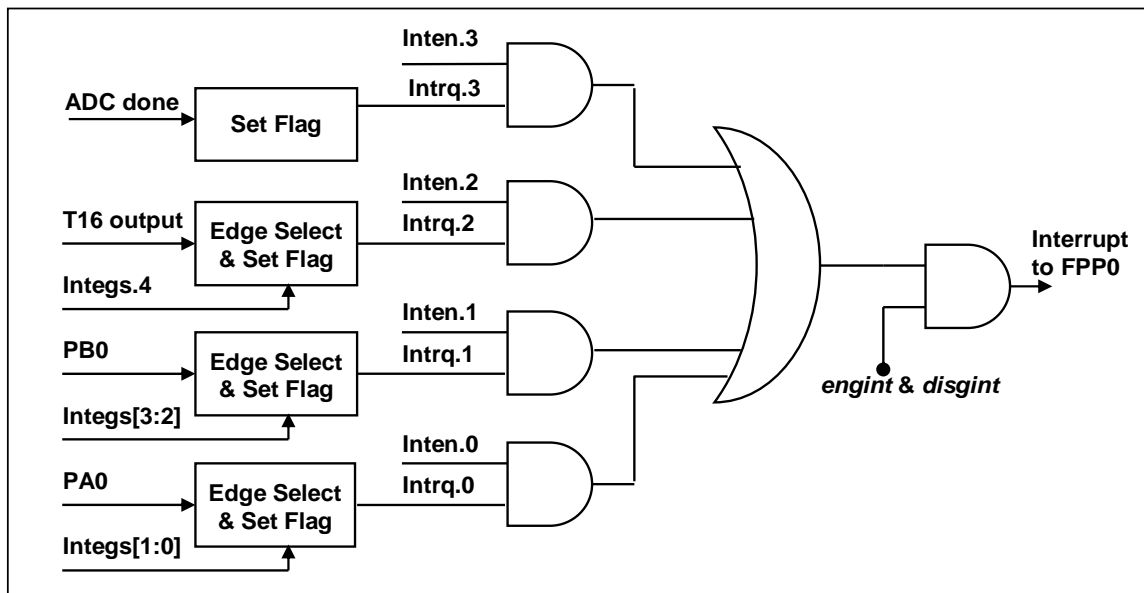

Fig. 12: Hardware diagram of Interrupt controller

Once the interrupt occurs, its operation will be:

- ◆ The program counter will be stored automatically to the stack memory specified by register *sp*.
- ◆ New *sp* will be updated to *sp+2*.
- ◆ Global interrupt will be disabled automatically.
- ◆ The next instruction will be fetched from address 0x010.

During the interrupt service routine, the interrupt source can be determined by reading the *intrq* register.

After finishing the interrupt service routine and issuing the *reti* instruction to return back, its operation will be:

- ◆ The program counter will be restored automatically from the stack memory specified by register sp.
- ◆ New sp will be updated to sp-2.
- ◆ Global interrupt will be enabled automatically.
- ◆ The next instruction will be the original one before interrupt.

User must reserve enough stack memory for interrupt, two bytes stack memory for one level interrupt and four bytes for two levels interrupt. For interrupt operation, the following sample program shows how to handle the interrupt, noticing that it needs four bytes stack memory to handle interrupt and *pushaf*.

```

void      FPPA0  (void)
{
    ...
    $ INTEN PA0;           // INTEN =1; interrupt request when PA0 level changed
    INTRQ = 0;            // clear INTRQ
    ENGINT                 // global interrupt enable
    ...
    DISGINT                // global interrupt disable
    ...
}

void      Interrupt (void) // interrupt service routine
{
    PUSHAF                 // store ALU and FLAG register
    If (INTRQ.0)           // Here for PA0 interrupt service routine
    {
        INTRQ.0 = 0;
        ...
    }
    ...
    POPAF                  // restore ALU and FLAG register
}

```

5.11. Power-Save and Power-Down

There are three operational modes defined by hardware: ON mode, Power-Save mode and Power-Down modes. ON mode is the state of normal operation with all functions ON, Power-save mode (“*stopexe*”) is the state to reduce operating current and CPU keeps ready to continue, Power-Down mode (“*stopsys*”) is used to save power deeply. Therefore, Power-save mode is used in the system which needs low operating power with wake-up occasionally and Power-Down mode is used in the system which needs power down deeply with seldom wake-up. Fig. 13 shows the differences in oscillator modules between Power-Save mode (“*stopexe*”) and Power-Down mode (“*stopsys*”).

Differences in oscillator modules between STOPSYS and STOPEXE			
	IHRC	ILRC	EOSC
STOPSYS	Stop	Stop	Stop
STOPEXE	No Change	No Change	No Change

Fig. 13: Differences in oscillator modules between STOPSYS and STOPEXE

5.11.1. Power-Save mode (“stopexe”)

Using “**stopexe**” instruction to enter the Power-Save mode, only system clock is disabled, remaining all the oscillator modules active. For CPU, it stops executing; however, for Timer16, counter keep counting if its clock source is not the system clock. The wake-up sources for “**stopexe**” can be IO-toggle or Timer16 counts to the set values when clock sources of Timer16 come from IHRC, ILRC or EOSC modules. Wake-up from input pins can be considered as a continuation of normal execution, **nop** command is recommended to follow the **stopexe** command, the detail information for Power-Save mode shows below:

- IHRC, ILRC and EOSC oscillator modules: No change, keep active if it was enabled
- System clock: Disable, therefore, CPU stops execution
- OTP memory is turned off
- Timer16: Stop counting if system clock is selected or the corresponding oscillator module is disabled; otherwise, it keeps counting.
- Wake-up sources: IO toggle or Timer16.

The watchdog timer must be disabled before issuing the “**stopexe**” command, the example is shown as below:

```

CLKMD.En_WatchDog = 0;      // disable watchdog timer
stopexe;
nop;
....                          // power saving
Wdreset;
CLKMD.En_WatchDog = 1;      // enable watchdog timer

```

Another example shows how to use Timer16 to wake-up from “**stopexe**”:

```

$ T16M IHRC, /1, BIT8      // Timer16 setting
...
WORD count = 0;
STT16 count;
stopexe;
nop;
...

```

The initial counting value of Timer16 is zero and the system will be waken up after the Timer16 counts 256 IHRC clocks.

5.11.2. Power-Down mode (“*stopsys*”)

Power-Down mode is the state of deeply power-saving with turning off all the oscillator modules. By using the “*stopsys*” instruction, this chip will be put on Power-Down mode directly. The internal low frequency RC oscillator must be enabled before entering the Power-Down mode, means that bit 2 of register ***clkmd*** (0x03) must be set to high before issuing “*stopsys*” command in order to resume the system when wakeup. The following shows the internal status of PMC271/PMS271 in detail when “*stopsys*” command is issued:

- All the oscillator modules are turned off
- Enable internal low RC oscillator (set bit 2 of register *clkmd*)
- OTP memory is turned off
- The contents of SRAM and registers remain unchanged
- Wake-up sources: ANY IO toggle.
- If PA or PB is input mode and set to analog input by ***padier*** or ***pbdir*** register, it can NOT be used to wake-up the system.

Wake-up from input pins can be considered as a continuation of normal execution. To minimize power consumption, all the I/O pins should be carefully manipulated before entering power-down mode. The reference sample program for power down is shown as below:

```

CMKMD    = 0xF4;    // Change clock from IHRC to ILRC
CLKMD.4  = 0;      // disable IHRC
...
while (1)
{
    STOPSYS;        // enter power-down
    if (...) break; // if wakeup happen and check OK, then return to high speed,
                       // else stay in power-down mode again.
}
CLKMD    = 0x34;    // Change clock from ILRC to IHRC/2

```

5.11.3. Wake-up

After entering the Power-Down or Power-Save modes, the PMC271/PMS271 can be resumed to normal operation by toggling IO pins, Timer16 interrupt is available for Power-Save mode ONLY. Fig. 14 shows the differences in wake-up sources between STOPSYS and STOPEXE.

Differences in wake-up sources between STOPSYS and STOPEXE		
	IO Toggle	T16 Interrupt
STOPSYS	Yes	No
STOPEXE	Yes	Yes

Fig. 14: Differences in wake-up sources between Power-Save mode and Power-Down mode

When using the IO pins to wake-up the PMC271/PMS271, registers *padier* and *pbdier* should be properly set to enable the wake-up function for every corresponding pin. The wake-up time for normal wake-up is about 1024 ILRC clocks counting from wake-up event; fast wake-up can be selected to reduce the wake-up time by *misc* register. For fast wake-up mechanism, the wake-up time is 128 system clocks from IO toggling if STOPEXE was issued, and 128 system clocks plus oscillator (IHRC or ILRC) stable time from IO toggling if STOPSYS was issued. The oscillator stable time is the time for IHRC or ILRC oscillator from power-on, depending on which oscillator is used as system clock source. Please notice that the fast wake-up will turn off automatically when EOSC is selected as system clock.

Suspend mode	wake-up mode	system clock source	wake-up time (t_{WUP}) from IO toggle
STOPEXE suspend	fast wake-up	IHRC or ILRC	$128 * T_{SYS}$, Where T_{SYS} is the time period of system clock
STOPSYS suspend	fast wake-up	IHRC	$128 T_{SYS} + T_{SIHRC}$; Where T_{SIHRC} is the stable time of IHRC from power-on.
STOPSYS suspend	fast wake-up	ILRC	$128 T_{SYS} + T_{SILRC}$; Where T_{SILRC} is the stable time of ILRC from power-on.
STOPSYS or STOPEXE suspend	fast wake-up	EOSC	$1024 * T_{ILRC}$, Where T_{ILRC} is the clock period of ILRC
STOPEXE suspend	normal wake-up	Any one	$1024 * T_{ILRC}$, Where T_{ILRC} is the clock period of ILRC
STOPSYS suspend	normal wake-up	Any one	$1024 * T_{ILRC}$, Where T_{ILRC} is the clock period of ILRC

Fig. 15: Wake-up time matching

Please notice that the clock source will be switched to system clock (for example: 4MHz) when fast wakeup is enabled, therefore, it is recommended to turn off the watchdog timer **before** enabling the fast wakeup and turn on the watchdog timer **after** disabling the fast wakeup.

5.12. IO Pins

Other than PA5, all the pins can be independently set into two states output or input by configuring the data registers (*pa*, *pb*), control registers (*pac*, *pbc*) and pull-high registers (*paph*, *pbph*). All these pins have Schmitt-trigger input buffer and output driver with CMOS level. When it is set to output low, the pull-up resistor is turned off automatically. If user wants to read the pin state, please notice that it should be set to input mode before reading the data port; if user reads the data port when it is set to output mode, the reading data comes from data register, NOT from IO pad. As an example, Table 6 shows the configuration table of bit 0 of port A. The hardware diagram of IO buffer is also shown as Fig. 16.

<i>pa.0</i>	<i>pac.0</i>	<i>paph.0</i>	Description
X	0	0	Input without pull-up resistor
X	0	1	Input with pull-up resistor
0	1	X	Output low without pull-up resistor
1	1	0	Output high without pull-up resistor
1	1	1	Output high with pull-up resistor

Table 6: PA0 Configuration Table

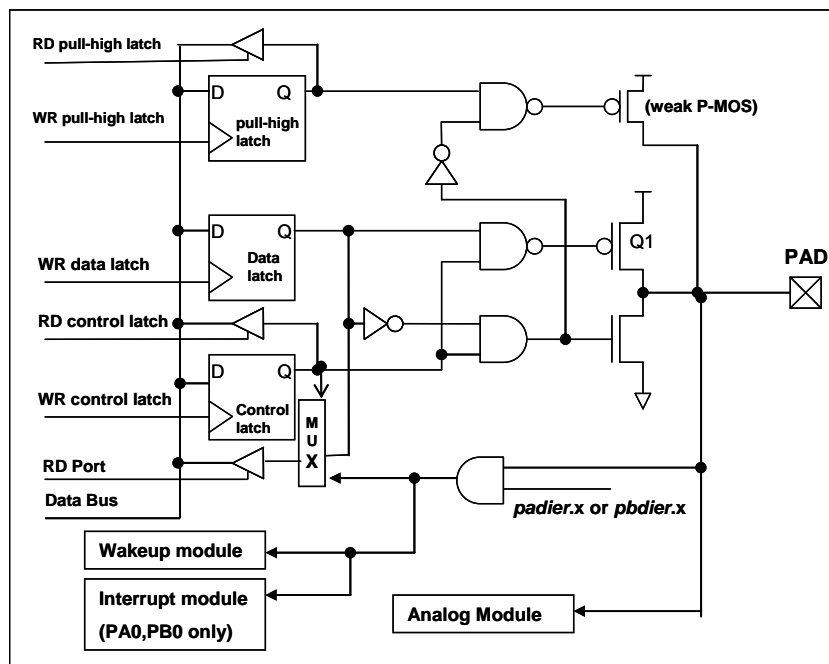

Fig. 16: Hardware diagram of IO buffer

Other than PA5, all the IO pins have the same structure; PA5 can be open-drain ONLY when setting to output mode (without Q1). The corresponding bits in registers *padier* / *pbdier* should be set to low to prevent leakage current for those pins are selected to be analog function. When PMC271/PMS271 is put in power-down or power-save mode, every pin can be used to wake-up system by toggling its state. Therefore, those pins needed to wake-up system must be set to input mode and set the corresponding bits of registers *padier* and *pbdier* to high. The same reason, *padier.0* should be set high when PA0 is used as external interrupt pin and *pbdier.0* for PB0.

5.13. Reset and LVR

5.13.1. Reset

There are many causes to reset the PMC271/PMS271, once reset is asserted, most of all the registers in PMC271/PMS271 will be set to default values, When reset comes from WDT timeout, **gdiio** register (IO address 0x7) keeps the same value, system should be restarted once abnormal cases happen, or by jumping program counter to address 'h0. The data memory is in uncertain state when reset comes from power-up and LVR; however, the content will be kept when reset comes from PRST# pin or WDT timeout.

5.13.2. LVR reset

By code option, there are 8 different levels of LVR for reset ~ 4.1V, 3.6V, 3.1V, 2.8V, 2.5V, 2.2V, 2.0V and 1.8V; usually, user selects LVR reset level to be in conjunction with operating frequency and supply voltage.

5.14. LCD Half VDD Bias Voltage

This function is used to generate half VDD bias voltage for LCD applications; however, it is NOT suitable for those in dire need of power saving products. This function is controlled by bit 4 of **misc** register, the PMC271/PMS271 will generate half VDD voltage on PA4 · PA3 · PA2 · PA1 pins after enabling this function. When these selected pins are going to have half VDD voltage function, user must program the PA4 · PA3 · PA2 · PA1 pins to input mode and PMC271/PMS271 will generate half VDD voltage to the corresponding pin automatically. If user wants to output VDD · 1/2VDD · GND three levels voltage, the corresponding pins must be set half VDD bias voltage and then output-high (VDD) · input (VDD/2) · output-low (GND) correspondingly. Fig. 17 shows how to use this Function:

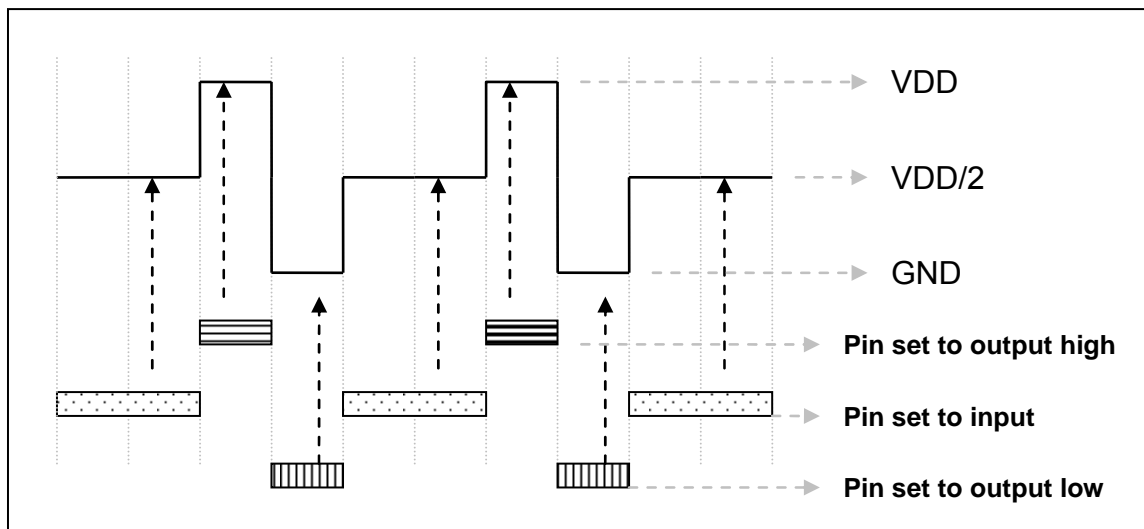

Fig. 17: Using VDD/2 bias voltage generator

5.15. Analog-to-Digital Conversion (ADC) module

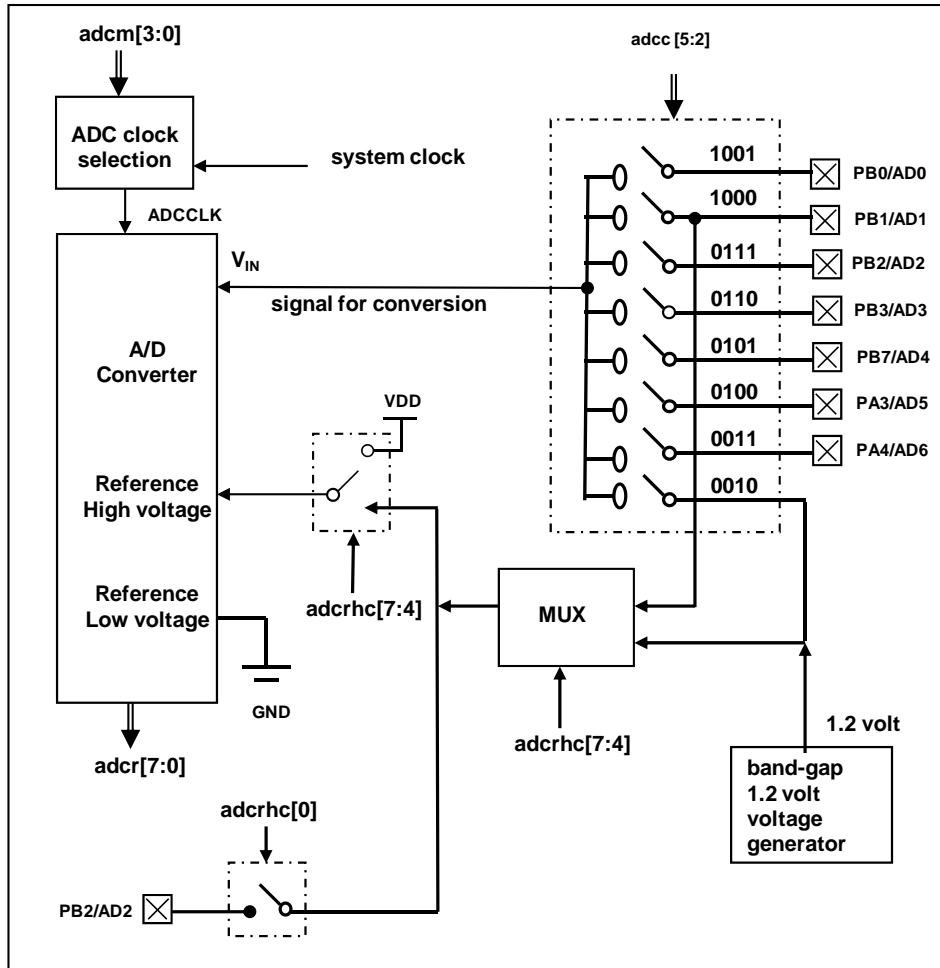

Fig. 18: ADC Block Diagram

There are eight input channels for the analog-to-digital conversion module; it allows conversion of an analog input signal to a corresponding 8-bit digital number. The hardware block diagram of ADC module is shown as Fig.18; the output of the sample and hold is the input into the converter which generates the result via successive approximation. The ADC reference low voltage is always GND. There are six registers for the ADC module, which are:

- ◆ ADC Control Register (*adcc*)
- ◆ ADC Mode Register (*adcm*)
- ◆ ADC Result Register (*adcr*)
- ◆ ADC Reference High Control Register (*adcrhc*)
- ◆ Port A Digital Input Disable Register (*padier*)
- ◆ Port B Digital Input Disable Register (*pbdier*)

After the ADC module has been configured as desired and the selected channel has been configured as analog input. The selected signal should be acquired before conversion, and the AD conversion can be started after the acquisition time has elapsed. The following steps should be followed to do the AD conversion:

(1) Configure the ADC module:

- ◆ Configure the voltage reference high by *adcrhc* register
- ◆ Select the ADC input channel by *adcc* register
- ◆ Configure the AD conversion clock by *adcm* register
- ◆ Configure the selected pin as analog input by *padier* and *pbdier* registers
- ◆ Enable the ADC module by *adcc* register

(2) Configure interrupt for ADC: (if desired)

- ◆ Clear the ADC interrupt request flag in bit 3 of *intrq* register
- ◆ Enable the ADC interrupt request in bit 3 of *inten* register
- ◆ Enable global interrupt by issuing *engint* command

(3) Start AD conversion:

- ◆ Set ADC process control bit in the *adcc* register to start the conversion (*set1 adcc.6*)

(4) Wait for the completion flag of AD conversion, by either:

- ◆ Waiting for the completion flag by using command “*wait1 adcc.6*”; or
- ◆ Waiting for the ADC interrupt.

(5) Read the ADC result registers:

- ◆ Read *adcr* the result registers

(6) For next conversion, goto step 1 or step 2 as required.

5.15.1 The input requirement for AD conversion

For the AD conversion to meet its specified accuracy, the charge holding capacitor (C_{HOLD}) must be allowed to fully charge to the voltage reference high level and discharge to the voltage reference low level. The analog input model is shown as Fig. 19, the signal driving source impedance (R_s) and the internal sampling switch impedance (R_{ss}) will affect the required time to charge the capacitor C_{HOLD} directly. The internal sampling switch impedance may vary with ADC supply voltage; the signal driving source impedance will affect accuracy of analog input signal. User must ensure the measured signal is stable before sampling; therefore, the maximum signal driving source impedance is highly dependent on the frequency of signal to be measured. The recommended maximum impedance for analog driving source is about 15K Ω under 500KHz input frequency and 8-bit resolution requirements, and 15M Ω under 500Hz input frequency and 8-bit resolution.

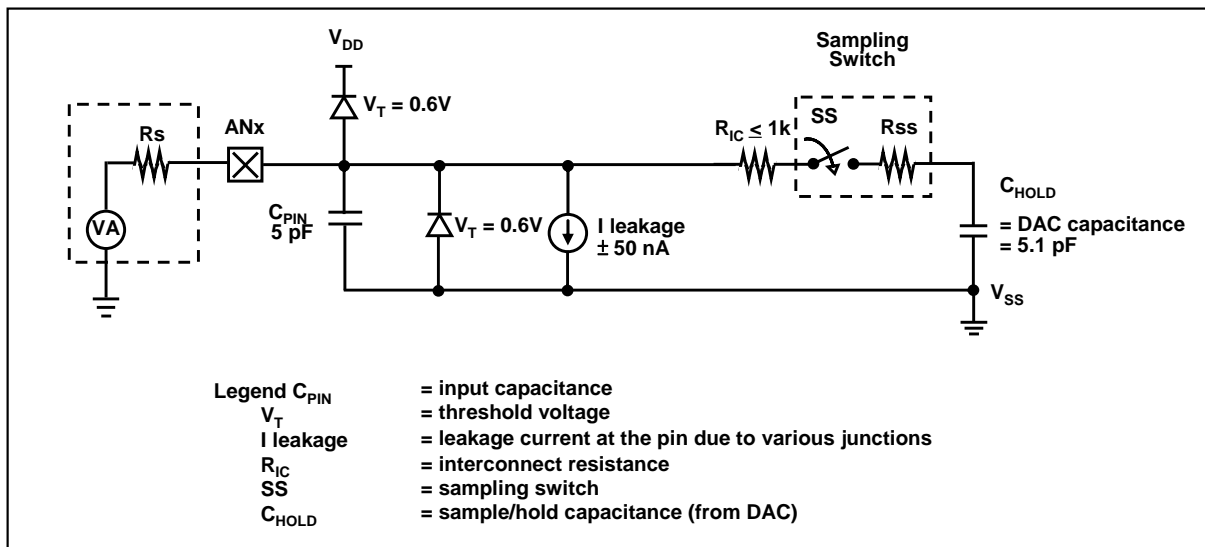

Fig. 19: Analog Input Model

Before starting the AD conversion, the minimum signal acquisition time should be met for the selected analog input signal. The signal acquisition time (T_{ACQ}) of ADC in PMC271/PMS271 series is fixed to one clock period of ADCLK; the selection of ADCLK must be met the minimum signal acquisition time.

5.15.2 ADC clock selection

The clock of ADC module (ADCLK) can be selected by **adcm** register; there are 8 possible options for ADCLK from $CLK \div 1$ to $CLK \div 128$ (CLK is the system clock). Due to the signal acquisition time T_{ACQ} is one clock period of ADCLK, the ADCLK must meet that requirement. The recommended ADC clock is to operate at 500KHz.

5.15.3 AD conversion

The process of AD conversion starts from setting START/DONE bit (bit 6 of **adcc**) to high, the START/DONE flag for read will be cleared automatically, then converting analog signal bit by bit and finally setting START/DONE high to indicate the completion of AD conversion. If ADCLK is selected, T_{ADCLK} is the period of ADCLK and the AD conversion time will be $12 T_{ADCLK}$.

5.15.4 Configuring the analog pins

The seven external analog input signals for ADC shared the same pins with port A or port B. To avoid leakage current at the digital circuit, those pins defined for analog input should be set to be analog input via **padier** or **pbdir** register. For those defined analog input pins, the value will be 0 when reading port A or port B.

6. IO Registers

6.1. ACC Status Flag Register (*flag*), IO address = 0x00

Bit	Reset	R/W	Description
7-4	-	-	Reserved. These four bits are "1" when read.
3	-	R/W	OV (Overflow). This bit is set whenever the sign operation is overflow.
2	-	R/W	AC (Auxiliary Carry). There are two conditions to set this bit, the first one is carry out of low nibble in addition operation, and the other one is borrow from the high nibble into low nibble in subtraction operation.
1	-	R/W	C (Carry). There are two conditions to set this bit, the first one is carry out in addition operation, and the other one is borrow in subtraction operation. Carry is also affected by shift with carry instruction.
0	-	R/W	Z (Zero). This bit will be set when the result of arithmetic or logic operation is zero; Otherwise, it is cleared.

6.2. FPP unit Enable Register (*fppen*), IO address = 0x01

Bit	Reset	R/W	Description
7-2	-	-	Reserved. Please keep 0.
1	0	W/R	FPP1 enable. This bit is used to enable FPP1. 0 / 1: disable / enable
0	1	W/R	FPP0 enable. This bit is used to enable FPP0. 0 / 1: disable / enable

6.3. Stack Pointer Register (*sp*), IO address = 0x02

Bit	Reset	R/W	Description
7-0	-	R/W	Stack Pointer Register. Read out the current stack pointer, or write to change the stack pointer. Please notice that bit 0 should be kept 0 due to program counter is 16 bits.

6.4. Clock Mode Register (*clkmd*), IO address = 0x03

Bit	Reset	R/W	Description
7-5	111	R/W	System clock selection:
			Type 0, clkmd[3]=0
			000: IHRC/4 001: IHRC/2 010: reserved 011: EOSC/4 100: EOSC/2 101: EOSC 110: ILRC/4 111: ILRC (default)
			000: IHRC/16 001: IHRC/8 010: reserved 011: IHRC/32 100: IHRC/64 101: EOSC/8 11x: reserved.
4	1	R/W	IHRC oscillator Enable. 0 / 1: disable / enable
3	0	RW	Clock Type Select. This bit is used to select the clock type in bit [7:5]. 0 / 1: Type 0 / Type 1
2	1	R/W	ILRC Enable. 0 / 1: disable / enable
1	1	R/W	Watch Dog Enable. 0 / 1: disable / enable
0	0	R/W	Pin PA5/PRST# function. 0 / 1: PA5 / PRST#.

6.5. Interrupt Enable Register (*inten*), IO address = 0x04

Bit	Reset	R/W	Description
7-4	-	R/W	Reserved.
3	-	R/W	Enable interrupt from ADC. 0 / 1: disable / enable.
2	-	R/W	Enable interrupt from Timer16 overflow. 0 / 1: disable / enable.
1	-	R/W	Enable interrupt from PB0. 0 / 1: disable / enable.
0	-	R/W	Enable interrupt from PA0. 0 / 1: disable / enable.

6.6. Interrupt Request Register (*intrq*), IO address = 0x05

Bit	Reset	R/W	Description
7-4	-	R/W	Reserved.
3	-	R/W	Interrupt Request from ADC, this bit is set by hardware and cleared by software. 0 / 1: No request / Request
2	-	R/W	Interrupt Request from Timer16, this bit is set by hardware and cleared by software. 0 / 1: No request / Request
1	-	R/W	Interrupt Request from pin PB0, this bit is set by hardware and cleared by software. 0 / 1: No request / Request
0	-	R/W	Interrupt Request from pin PA0, this bit is set by hardware and cleared by software. 0 / 1: No request / Request

6.7. Timer 16 mode Register (t16m), IO address = 0x06

Bit	Reset	R/W	Description
7-5	000	R/W	Timer Clock source selection 000: Timer 16 is disabled 001: CLK (system clock) 01X: reserved 100: IHRC 101: EOSC 110: ILRC 111: PA0 (from external pin)
4-3	00	R/W	Internal clock divider. 00: ÷1 01: ÷4 10: ÷16 11: ÷64
2-0	000	R/W	Interrupt source selection. Interrupt event happens when selected bit goes high. 0 : bit 8 of Timer16 1 : bit 9 of Timer16 2 : bit 10 of Timer16 3 : bit 11 of Timer16 4 : bit 12 of Timer16 5 : bit 13 of Timer16 6 : bit 14 of Timer16 7 : bit 15 of Timer16

6.8. General Data register for IO (gdio), IO address = 0x07

Bit	Reset	R/W	Description
7-0	00	R/W	General data for IO. This port is the general data buffer in IO space and <u>cleared only when POR, LVR or pin PRST# is active, NOT cleared by watch-dog timeout reset.</u> It can perform the IO operation, like wait0 gdio.x, wait1 gdio.x and tog gdio.x to take the replace of operations which instructions are supported in memory space (ex: wait1 mem; wait0 mem; tog mem).

6.9. External Oscillator setting Register (eoscr, write only), IO address = 0x0a

Bit	Reset	R/W	Description
7	0	WO	Enable crystal oscillator. 0 / 1 : Disable / Enable
6-5	00	WO	External crystal oscillator selection. 00 : reserved 01 : Low driving capability, for lower frequency, ex: 32KHz crystal oscillator 10 : Middle driving capability, for middle frequency, ex: 1MHz crystal oscillator 11 : High driving capability, for higher frequency, ex: 4MHz crystal oscillator
4-1	-	-	Reserved. Please keep 0.
0	0	WO	Power-down the Band-gap and LVR hardware modules. 0 / 1: normal / power-down.

6.10. IHRC oscillator control Register (*ihrcr*, write only), IO address = 0x0b

Bit	Reset	R/W	Description
7-0	--	WO	Bit [7:0] of internal high RC oscillator for frequency calibration. <i>For system using only, please user do NOT write this register.</i>

6.11. Interrupt Edge Select Register (*integs*), IO address = 0x0c

Bit	Reset	R/W	Description
7-5	-	-	Reserved. Please keep 0.
4	0	WO	Timer16 edge selection. 0 : rising edge to trigger interrupt 1 : falling edge to trigger interrupt
3-2	00	WO	PB0 edge selection. 00 : both rising edge and falling edge to trigger interrupt 01 : rising edge to trigger interrupt 10 : falling edge to trigger interrupt 11 : reserved.
1-0	00	WO	PA0 edge selection. 00 : both rising edge and falling edge to trigger interrupt 01 : rising edge to trigger interrupt 10 : falling edge to trigger interrupt 11 : reserved.

6.12. Port A Digital Input Enable Register (*padier*), IO address = 0x0d

Bit	Reset	R/W	Description
7	1	WO	Enable PA7 digital input and wake-up event. 1 / 0 : enable / disable. This bit should be set to low to prevent leakage current when external crystal oscillator is used. If this bit is set to low, PA7 can NOT be used to wake-up the system. Note: For ICE emulation, the function is disabled when this bit is "1" and "0" is enabled.
6	1	WO	Enable PA6 digital input and wake-up event. 1 / 0 : enable / disable. This bit should be set to low to prevent leakage current when external crystal oscillator is used. If this bit is set to low, PA6 can NOT be used to wake-up the system. Note: For ICE emulation, the function is disabled when this bit is "1" and "0" is enabled.
5	1	WO	Enable PA5 wake-up event. 1 / 0 : enable / disable. This bit can be set to low to disable wake-up from PA5 toggling. Note: For ICE emulation, wakeup is disabled when this bit is "1" and "0" is enabled.
4	1	WO	Enable PA4 digital input and wake-up event. 1 / 0 : enable / disable. This bit should be set to low when PA4 is assigned as AD input to prevent leakage current. If this bit is set to low, PA4 can NOT be used to wake-up the system. Note: For ICE emulation, the function is disabled when this bit is "1" and "0" is enabled.
3	1	WO	Enable PA3 digital input and wake-up event. 1 / 0 : enable / disable. This bit should be set to low when PA3 is assigned as AD input to prevent leakage current. If this bit is set to low, PA3 can NOT be used to wake-up the system. Note: For ICE emulation, the function is disabled when this bit is "1" and "0" is enabled.
2	1	WO	Enable PA2 wake-up event. 1 / 0 : enable / disable. This bit can be set to low to disable wake-up from PA2 toggling. Note: For ICE emulation, wakeup is disabled when this bit is "1" and "0" is enabled.
1	1	WO	Enable PA1 wake-up event. 1 / 0 : enable / disable. This bit can be set to low to disable wake-up from PA1 toggling. Note: For ICE emulation, wakeup is disabled when this bit is "1" and "0" is enabled.
0	1	WO	Enable PA0 wake-up event and interrupt request. 1 / 0 : enable / disable. This bit can be set to low to disable wake-up from PA0 toggling and interrupt request from this pin. Note: For ICE emulation, the function is disabled when this bit is "1" and "0" is enabled.

Note: Due to the controlling polarity of this register is different between ICE and real chip. In order to unify the program for both ICE emulation and real chip to be the same one, please use the following command to write this register:

```
"$ PADIER    0xhh" ;
```

For example:

```
$ PADIER    0xF0;
```

It is used to enable the digital input and wakeup function of bit [7:4] of port A for both ICE and real chip, IDE will handle the difference between ICE and real chip automatically.

6.13. Port B Digital Input Enable Register (*pbdier*), IO address = 0x0e

Bit	Reset	R/W	Description
7	1	WO	Enable PB7 digital input and wake-up event. 1 / 0 : enable / disable. This bit should be set to low when PB7 is assigned as AD input to prevent leakage current. If this bit is set to low, PB7 can NOT be used to wake-up the system. Note: For ICE emulation, the function is disabled when this bit is “1” and “0” is enabled.
6	1	WO	Enable PB6 wake-up event. 1 / 0 : enable / disable. This bit can be set to low to disable wake-up from PB6 toggling. Note: For ICE emulation, wakeup is disabled when this bit is “1” and “0” is enabled.
5	1	WO	Enable PB5 wake-up event. 1 / 0 : enable / disable. This bit can be set to low to disable wake-up from PB5 toggling. Note: For ICE emulation, wakeup is disabled when this bit is “1” and “0” is enabled.
4	1	WO	Enable PB4 wake-up event. 1 / 0 : enable / disable. This bit can be set to low to disable wake-up from PB4 toggling. Note: For ICE emulation, wakeup is disabled when this bit is “1” and “0” is enabled.
3	1	WO	Enable PB3 digital input and wake-up event. 1 / 0 : enable / disable. This bit should be set to low when PB3 is assigned as AD input to prevent leakage current. If this bit is set to low, PB3 can NOT be used to wake-up the system. Note: For ICE emulation, the function is disabled when this bit is “1” and “0” is enabled.
2	1	WO	Enable PB2 digital input and wake-up event. 1 / 0 : enable / disable. This bit should be set to low when PB2 is assigned as AD input to prevent leakage current. If this bit is set to low, PB2 can NOT be used to wake-up the system. Note: For ICE emulation, the function is disabled when this bit is “1” and “0” is enabled.
1	1	WO	Enable PB1 digital input and wake-up event. 1 / 0 : enable / disable. This bit should be set to low when PB1 is assigned as AD input to prevent leakage current. If this bit is set to low, PB1 can NOT be used to wake-up the system. Note: For ICE emulation, the function is disabled when this bit is “1” and “0” is enabled.
0	1	WO	Enable PB0 digital input, wake-up event and interrupt request. 1 / 0 : enable / disable. This bit should be set to low when PB0 is assigned as AD input to prevent leakage current. If this bit is set to low, PB0 can NOT be used to wake-up the system and interrupt request from this pin. Note: For ICE emulation, the function is disabled when this bit is “1” and “0” is enabled.

Note: Due to the controlling polarity of this register is different between ICE and real chip. In order to unify the program for both ICE emulation and real chip to be the same one, please use the following command to write this register:

```
“$ PBDIER    0xhh” ;
```

For example:

```
$ PBDIER    0xF0;
```

It is used to enable the digital input and wakeup function of bit [7:4] of port B for both ICE and real chip, IDE will handle the difference between ICE and real chip automatically.

6.14. Port A Data Registers (*pa*), IO address = 0x10

Bit	Reset	R/W	Description
7-0	8'h00	R/W	Data registers for Port A.

6.15. Port A Control Registers (*pac*), IO address = 0x11

Bit	Reset	R/W	Description
7-0	8'h00	R/W	Port A control registers. This register is used to define input mode or output mode for each corresponding pin of port A. 0 / 1: input / output.

6.16. Port A Pull-High Registers (*paph*), IO address = 0x12

Bit	Reset	R/W	Description
7-0	8'h00	R/W	Port A pull-high registers. This register is used to enable the internal pull-high device on each corresponding pin of port A. 0 / 1 : disable / enable Please note that the PA5 does not have pull-up resistor.

6.17. Port B Data Registers (*pb*), IO address = 0x14

Bit	Reset	R/W	Description
7-0	8'h00	R/W	Data registers for Port B.

6.18. Port B Control Registers (*pbcb*), IO address = 0x15

Bit	Reset	R/W	Description
7-0	8'h00	R/W	Port B control registers. This register is used to define input mode or output mode for each corresponding pin of port B. 0 / 1: input / output

6.19. Port B Pull-High Registers (*pbph*), IO address = 0x16

Bit	Reset	R/W	Description
7-0	8'h00	R/W	Port B pull-high registers. This register is used to enable the internal pull-high device on each corresponding pin of port B. 0 / 1 : disable / enable

6.20. ADC Control Register (*adcc*), IO address = 0x20

Bit	Reset	R/W	Description
7	0	R/W	Enable ADC function. 0/1: Disable/Enable.
6	0	R/W	ADC process control bit. Write "1" to start AD conversion, and the completion flag is cleared automatically; Read "1" to indicate the completion of AD conversion.
5-2	0000	R/W	Channel selector. These four bits are used to select input signal for AD conversion. 0000:PB0 0001:PB1 0010:PB2 0011:PB3. 0111:PB7 1000:PA3 1001:PA4 1111: 1.20V band-gap reference voltage Others: reserved
1-0	-	-	Reserved, please keep 0.

6.21. ADC Mode Register (*adcm*, write only), IO address = 0x21

Bit	Reset	R/W	Description
7-5	-	-	Reserved
4-1	0000	WO	ADC clock source selection. 0000: CLK÷1 0001:CLK÷2 0010:CLK÷4 0011:CLK÷8 0100:CLK÷16 0101:CLK÷32 0110:CLK÷64 0111:CLK÷128, Others: reserved. Where, CLK is the system clock.
0	-	-	Reserved

6.22. ADC Result Register (*adcr*, read only), IO address = 0x22

Bit	Reset	R/W	Description
7-0	-	RO	These eight read-only bits will be the bit [7:0] of AD conversion result.

6.23. ADC Reference High Control Register (*adcrhc*), IO address = 0x1c

Bit	Reset	R/W	Description
7:4	0000	R/W	ADC Reference high selection: 0000: Reference high is VDD voltage level. 0001: Reference high is PB1 voltage level. Note: $PB1 \leq (2/3)VDD$ is required to keep the accuracy of AD conversion. 0010: Reference high is band-gap voltage level. Others: reserved, please keep as 0.
3:1	-	-	Reserved. (please keep as 0)
0	0	R/W	Enable ADC Reference high voltage output to PB2. 0 / 1 : disable / enabled Notes: (1) If this bit is enabled, must set PB2 as input mode and NOT drive this pin externally. (2) The ADC reference high which is sent to PB2 comes from PB1 input or band-gap reference voltage only, please see the block diagram. (3) If band-gap reference voltage is sent to PB2 and AD conversion input signal at the same time, the conversion result may not be correct, please do NOT use simultaneously.

6.24 RESET Status Register (*rstst*), IO address = 0x25

Bit	Reset (POR only)	R/W	Description
7 - 4	-	-	Reserved. Please don't use..
3	-	R/W	MCU reset from external reset pin (PA5)? This bit is set to high whenever reset occurs from PA5 pin, and reset only when writing "0" to clear this bit or POR (power-on-reset) happens. 0 / 1 : No / Yes.
2	-	R/W	VDD had been lower than 4V? This bit is set to high whenever VDD under 4V and reset only when writing "0" to clear this bit or POR (power-on-reset) happens. 0 / 1 : No / Yes.
1	-	R/W	VDD had been lower than 3V? This bit is set to high whenever VDD under 3V and reset only when writing "0" to clear this bit or POR (power-on-reset) happens. 0 / 1 : No / Yes.
0	-	R/W	VDD had been lower than 2V? This bit is set to high whenever VDD under 2V and reset only when writing "0" to clear this bit or POR (power-on-reset) happens. 0 / 1 : No / Yes.

6.23. MISC Register (*misc*), IO address = 0x3b

Bit	Reset	R/W	Description
7	0	-	Reserved
6	0	WO	Enable extremely low current for 32KHz crystal oscillator AFTER oscillation. 0: Normal. 1: Low driving current for 32KHz crystal oscillator.
5	0	WO	Enable fast Wake-up. Fast wake-up is NOT supported when EOSC is enabled. 0: Normal wake-up. The wake-up time is 1024 ILRC clocks 1: Fast wake-up. (for The wake-up time is 128 CLKs (system clock) + oscillator stable time. If wake-up from STOPEXE suspend, there is no oscillator stable time; If wake-up from STOPSYS suspend, it will be IHRC or ILRC stable time from power-on. Please notice that the clock source will be switched to system clock (for example: 4MHz) when fast wakeup is enabled, therefore, it is recommended to turn off the watchdog timer before enabling the fast wakeup and turn on the watchdog timer after disabling the fast wakeup.
4	0	WO	Enable to generate half VDD on PA0/PA1/PA2/PA3 pins. 0 / 1 : Disable / Enable
3	0	WO	Recover time from LVR reset. 0: Normal. The system will take about 1024 ILRC clocks to boot up from LVR reset. 1: Fast. The system will take about 64 ILRC clocks to boot up from LVR reset.
2	0	WO	Disable LVR function. 0 / 1 : Enable / Disable
1-0	00	WO	Watch dog time out period 00: 2048 ILRC clock period 01: 4096 ILRC clock period 10: 16384 ILRC clock period 11: 256 ILRC clock period

7. Instructions

Symbol	Description
ACC	Accumulator
a	Accumulator
sp	Stack pointer
flag	ACC status flag register
l	Immediate data
&	Logical AND
	Logical OR
←	Movement
^	Exclusive logic OR
+	Add
−	Subtraction
~	NOT (logical complement, 1's complement)
$\overline{\text{T}}$	NEG (2's complement)
OV	Overflow (The operational result is out of range in signed 2's complement number system)
Z	Zero (If the result of ALU operation is zero, this bit is set to 1)
C	Carry (The operational result is to have carry out for addition or to borrow carry for subtraction in unsigned number system)
AC	Auxiliary Carry (If there is a carry out from low nibble after the result of ALU operation, this bit is set to 1)
pc0	Program counter for FPP0
pc1	Program counter for FPP1

7.1. Data Transfer Instructions

<i>mov</i> a, I	<p>Move immediate data into ACC. Example: <i>mov</i> a, 0x0f; Result: $a \leftarrow 0fh$; Affected flags: 『N』 Z 『N』 C 『N』 AC 『N』 OV</p>
<i>mov</i> M, a	<p>Move data from ACC into memory Example: <i>mov</i> MEM, a; Result: $MEM \leftarrow a$ Affected flags: 『N』 Z 『N』 C 『N』 AC 『N』 OV</p>
<i>mov</i> a, M	<p>Move data from memory into ACC Example: <i>mov</i> a, MEM ; Result: $a \leftarrow MEM$; Flag Z is set when MEM is zero. Affected flags: 『Y』 Z 『N』 C 『N』 AC 『N』 OV</p>
<i>mov</i> a, IO	<p>Move data from IO into ACC Example: <i>mov</i> a, pa ; Result: $a \leftarrow pa$; Flag Z is set when pa is zero. Affected flags: 『Y』 Z 『N』 C 『N』 AC 『N』 OV</p>
<i>mov</i> IO, a	<p>Move data from ACC into IO Example: <i>mov</i> pb, a; Result: $pb \leftarrow a$ Affected flags: 『N』 Z 『N』 C 『N』 AC 『N』 OV</p>
<i>nmov</i> M, a	<p>Take the negative logic (2's complement) of ACC to put on memory Example: <i>nmov</i> MEM, a; Result: $MEM \leftarrow \overline{a}$ Affected flags: 『N』 Z 『N』 C 『N』 AC 『N』 OV Application Example:</p> <hr style="border-top: 1px dashed black;"/> <pre style="margin-left: 40px;"> <i>mov</i> a, 0xf5 ; // ACC is 0xf5 <i>nmov</i> ram9, a; // ram9 is 0x0b, ACC is 0xf5 </pre> <hr style="border-top: 1px dashed black;"/>
<i>nmov</i> a, M	<p>Take the negative logic (2's complement) of memory to put on ACC Example: <i>nmov</i> a, MEM ; Result: $a \leftarrow \overline{MEM}$; Flag Z is set when \overline{MEM} is zero. Affected flags: 『Y』 Z 『N』 C 『N』 AC 『N』 OV Application Example:</p> <hr style="border-top: 1px dashed black;"/> <pre style="margin-left: 40px;"> <i>mov</i> a, 0xf5 ; <i>mov</i> ram9, a ; // ram9 is 0xf5 <i>nmov</i> a, ram9 ; // ram9 is 0xf5, ACC is 0x0b </pre> <hr style="border-top: 1px dashed black;"/>

<i>ldtabh</i> index	<p>Load high byte data in OTP program memory to ACC by using index as OTP address. It needs 2T to execute this instruction.</p> <p>Example: <i>ldtabh</i> index;</p> <p>Result: a ← {bit 15~8 of OTP [index]};</p> <p>Affected flags: 『N』 Z 『N』 C 『N』 AC 『N』 OV</p> <p>Application Example:</p> <hr style="border-top: 1px dashed black;"/> <pre style="margin: 0;">word ROMptr ; // declare a pointer of ROM in RAM ... mov a, la@TableA ; // assign pointer to ROM TableA (LSB) mov lb@ROMptr, a ; // save pointer to RAM (LSB) mov a, ha@TableA ; // assign pointer to ROM TableA (MSB) mov hb@ROMptr, a ; // save pointer to RAM (MSB) ... ldtabh ROMptr ; // load TableA MSB to ACC (ACC=0X02) TableA: dc 0x0234, 0x0042, 0x0024, 0x0018 ;</pre> <hr style="border-top: 1px dashed black;"/>
<i>ldtbl</i> index	<p>Load low byte data in OTP to ACC by using index as OTP address. It needs 2T to execute this instruction.</p> <p>Example: <i>ldtbl</i> index;</p> <p>Result: a ← {bit7~0 of OTP [index]};</p> <p>Affected flags: 『N』 Z 『N』 C 『N』 AC 『N』 OV</p> <p>Application Example:</p> <hr style="border-top: 1px dashed black;"/> <pre style="margin: 0;">word ROMptr ; // declare a pointer of ROM in RAM ... mov a, la@TableA ; // assign pointer to ROM TableA (LSB) mov lb@ROMptr, a ; // save pointer to RAM (LSB) mov a, ha@TableA ; // assign pointer to ROM TableA (MSB) mov hb@ROMptr, a ; // save pointer to RAM (MSB) ... ldtbl ROMptr ; // load TableA LSB to ACC (ACC=0x34) TableA: dc 0x0234, 0x0042, 0x0024, 0x0018 ;</pre> <hr style="border-top: 1px dashed black;"/>

<i>ldt16</i> word	<p>Move 16-bit counting values in Timer16 to memory in word. Example: <i>ldt16</i> word; Result: word ← 16-bit timer Affected flags: 『N』 Z 『N』 C 『N』 AC 『N』 OV</p> <p>Application Example:</p> <hr style="border-top: 1px dashed black;"/> <pre style="margin: 0;">word T16val ; // declare a RAM word ... clear lb@ T16val ; // clear T16val (LSB) clear hb@ T16val ; // clear T16val (MSB) stt16 T16val ; // initial T16 with 0 ... set1 t16m.5 ; // enable Timer16 ... set0 t16m.5 ; // disable Timer 16 ldt16 T16val ; // save the T16 counting value to T16val</pre> <hr style="border-top: 1px dashed black;"/>
<i>stt16</i> word	<p>Store 16-bit data from memory in word to Timer16. Example: <i>stt16</i> word; Result: 16-bit timer ← word Affected flags: 『N』 Z 『N』 C 『N』 AC 『N』 OV</p> <p>Application Example:</p> <hr style="border-top: 1px dashed black;"/> <pre style="margin: 0;">word T16val ; // declare a RAM word ... mov a, 0x34 ; mov lb@ T16val , a ; // move 0x34 to T16val (LSB) mov a, 0x12 ; mov hb@ T16val , a ; // move 0x12 to T16val (MSB) stt16 T16val ; // initial T16 with 0x1234 ... </pre> <hr style="border-top: 1px dashed black;"/>

<i>idxm</i> a, index	<p>Move data from specified memory to ACC by indirect method. It needs 2T to execute this instruction.</p> <p>Example: <i>idxm</i> a, index;</p> <p>Result: a ← [index], where index is declared by word.</p> <p>Affected flags: 『N』 Z 『N』 C 『N』 AC 『N』 OV</p> <p>Application Example:</p> <hr style="border-top: 1px dashed black;"/> <pre style="margin: 0;">word RAMIndex ; // declare a RAM pointer ... mov a, 0x5B ; // assign pointer to an address (LSB) mov lb@RAMIndex, a ; // save pointer to RAM (LSB) mov a, 0x00 ; // assign 0x00 to an address (MSB), should be 0 mov hb@RAMIndex, a ; // save pointer to RAM (MSB) ... idxm a, RAMIndex ; // mov memory data in address 0x5B to ACC</pre> <hr style="border-top: 1px dashed black;"/>
<i>ldxm</i> index, a	<p>Move data from ACC to specified memory by indirect method. It needs 2T to execute this instruction.</p> <p>Example: <i>ldxm</i> index, a;</p> <p>Result: [index] ← a; where index is declared by word.</p> <p>Affected flags: 『N』 Z 『N』 C 『N』 AC 『N』 OV</p> <p>Application Example:</p> <hr style="border-top: 1px dashed black;"/> <pre style="margin: 0;">word RAMIndex ; // declare a RAM pointer ... mov a, 0x5B ; // assign pointer to an address (LSB) mov lb@RAMIndex, a ; // save pointer to RAM (LSB) mov a, 0x00 ; // assign 0x00 to an address (MSB), should be 0 mov hb@RAMIndex, a ; // save pointer to RAM (MSB) ... mov a, 0xA5 ; idxm RAMIndex, a ; // mov 0xA5 to memory in address 0x5B</pre> <hr style="border-top: 1px dashed black;"/>

<i>xch</i> M	<p>Exchange data between ACC and memory</p> <p>Example: <i>xch</i> MEM ;</p> <p>Result: MEM ← a , a ← MEM</p> <p>Affected flags: 『N』 Z 『N』 C 『N』 AC 『N』 OV</p>
<i>pushaf</i>	<p>Move the ACC and flag register to memory that address specified in the stack pointer.</p> <p>Example: <i>pushaf</i>;</p> <p>Result: [sp] ← {flag, ACC}; sp ← sp + 2 ;</p> <p>Affected flags: 『N』 Z 『N』 C 『N』 AC 『N』 OV</p> <p>Application Example:</p> <hr style="border-top: 1px dashed black;"/> <pre>.romadr 0x10 ; // ISR entry address <i>pushaf</i> ; // put ACC and flag into stack memory ... // ISR program ... // ISR program <i>popaf</i> ; // restore ACC and flag from stack memory <i>reti</i> ;</pre> <hr style="border-top: 1px dashed black;"/>
<i>popaf</i>	<p>Restore ACC and flag from the memory which address is specified in the stack pointer.</p> <p>Example: <i>popaf</i>;</p> <p>Result: sp ← sp - 2 ; {Flag, ACC} ← [sp] ;</p> <p>Affected flags: 『Y』 Z 『Y』 C 『Y』 AC 『Y』 OV</p>

7.2. Arithmetic Operation Instructions

<i>add</i> a, l	Add immediate data with ACC, then put result into ACC Example: <i>add</i> a, 0x0f ; Result: $a \leftarrow a + 0fh$ Affected flags: 『Y』 Z 『Y』 C 『Y』 AC 『Y』 OV
<i>add</i> a, M	Add data in memory with ACC, then put result into ACC Example: <i>add</i> a, MEM ; Result: $a \leftarrow a + MEM$ Affected flags: 『Y』 Z 『Y』 C 『Y』 AC 『Y』 OV
<i>add</i> M, a	Add data in memory with ACC, then put result into memory Example: <i>add</i> MEM, a ; Result: $MEM \leftarrow a + MEM$ Affected flags: 『Y』 Z 『Y』 C 『Y』 AC 『Y』 OV
<i>addc</i> a, M	Add data in memory with ACC and carry bit, then put result into ACC Example: <i>addc</i> a, MEM ; Result: $a \leftarrow a + MEM + C$ Affected flags: 『Y』 Z 『Y』 C 『Y』 AC 『Y』 OV
<i>addc</i> M, a	Add data in memory with ACC and carry bit, then put result into memory Example: <i>addc</i> MEM, a ; Result: $MEM \leftarrow a + MEM + C$ Affected flags: 『Y』 Z 『Y』 C 『Y』 AC 『Y』 OV
<i>addc</i> a	Add carry with ACC, then put result into ACC Example: <i>addc</i> a ; Result: $a \leftarrow a + C$ Affected flags: 『Y』 Z 『Y』 C 『Y』 AC 『Y』 OV
<i>addc</i> M	Add carry with memory, then put result into memory Example: <i>addc</i> MEM ; Result: $MEM \leftarrow MEM + C$ Affected flags: 『Y』 Z 『Y』 C 『Y』 AC 『Y』 OV
<i>nadd</i> a, M	Add negative logic (2's complement) of ACC with memory Example: <i>nadd</i> a, MEM ; Result: $a \leftarrow \overline{a} + MEM$ Affected flags: 『Y』 Z 『Y』 C 『Y』 AC 『Y』 OV
<i>nadd</i> M, a	Add negative logic (2's complement) of memory with ACC Example: <i>nadd</i> MEM, a ; Result: $MEM \leftarrow \overline{MEM} + a$ Affected flags: 『Y』 Z 『Y』 C 『Y』 AC 『Y』 OV
<i>sub</i> a, l	Subtraction immediate data from ACC, then put result into ACC. Example: <i>sub</i> a, 0x0f ; Result: $a \leftarrow a - 0fh$ ($a + [2's \text{ complement of } 0fh]$) Affected flags: 『Y』 Z 『Y』 C 『Y』 AC 『Y』 OV
<i>sub</i> a, M	Subtraction data in memory from ACC, then put result into ACC Example: <i>sub</i> a, MEM ; Result: $a \leftarrow a - MEM$ ($a + [2's \text{ complement of } M]$) Affected flags: 『Y』 Z 『Y』 C 『Y』 AC 『Y』 OV

<i>sub</i> M, a	<p>Subtraction data in ACC from memory, then put result into memory</p> <p>Example: <i>sub</i> MEM, a;</p> <p>Result: $MEM \leftarrow MEM - a$ ($MEM + [2\text{'s complement of } a]$)</p> <p>Affected flags: 『Y』 Z 『Y』 C 『Y』 AC 『Y』 OV</p>
<i>subc</i> a, M	<p>Subtraction data in memory and carry from ACC, then put result into ACC</p> <p>Example: <i>subc</i> a, MEM;</p> <p>Result: $a \leftarrow a - MEM - C$</p> <p>Affected flags: 『Y』 Z 『Y』 C 『Y』 AC 『Y』 OV</p>
<i>subc</i> M, a	<p>Subtraction ACC and carry bit from memory, then put result into memory</p> <p>Example: <i>subc</i> MEM, a ;</p> <p>Result: $MEM \leftarrow MEM - a - C$</p> <p>Affected flags: 『Y』 Z 『Y』 C 『Y』 AC 『Y』 OV</p>
<i>subc</i> a	<p>Subtraction carry from ACC, then put result into ACC</p> <p>Example: <i>subc</i> a;</p> <p>Result: $a \leftarrow a - C$</p> <p>Affected flags: 『Y』 Z 『Y』 C 『Y』 AC 『Y』 OV</p>
<i>subc</i> M	<p>Subtraction carry from the content of memory, then put result into memory</p> <p>Example: <i>subc</i> MEM;</p> <p>Result: $MEM \leftarrow MEM - C$</p> <p>Affected flags: 『Y』 Z 『Y』 C 『Y』 AC 『Y』 OV</p>
<i>inc</i> M	<p>Increment the content of memory</p> <p>Example: <i>inc</i> MEM ;</p> <p>Result: $MEM \leftarrow MEM + 1$</p> <p>Affected flags: 『Y』 Z 『Y』 C 『Y』 AC 『Y』 OV</p>
<i>dec</i> M	<p>Decrement the content of memory</p> <p>Example: <i>dec</i> MEM;</p> <p>Result: $MEM \leftarrow MEM - 1$</p> <p>Affected flags: 『Y』 Z 『Y』 C 『Y』 AC 『Y』 OV</p>
<i>clear</i> M	<p>Clear the content of memory</p> <p>Example: <i>clear</i> MEM ;</p> <p>Result: $MEM \leftarrow 0$</p> <p>Affected flags: 『N』 Z 『N』 C 『N』 AC 『N』 OV</p>

7.3. Shift Operation Instructions

<i>sr a</i>	Shift right of ACC Example: <i>sr a</i> ; Result: $a(0, b7, b6, b5, b4, b3, b2, b1) \leftarrow a(b7, b6, b5, b4, b3, b2, b1, b0)$, $C \leftarrow a(b0)$ Affected flags: 『N』 Z 『Y』 C 『N』 AC 『N』 OV
<i>src a</i>	Shift right of ACC with carry Example: <i>src a</i> ; Result: $a(c, b7, b6, b5, b4, b3, b2, b1) \leftarrow a(b7, b6, b5, b4, b3, b2, b1, b0)$, $C \leftarrow a(b0)$ Affected flags: 『N』 Z 『Y』 C 『N』 AC 『N』 OV
<i>sr M</i>	Shift right the content of memory Example: <i>sr MEM</i> ; Result: $MEM(0, b7, b6, b5, b4, b3, b2, b1) \leftarrow MEM(b7, b6, b5, b4, b3, b2, b1, b0)$, $C \leftarrow MEM(b0)$ Affected flags: 『N』 Z 『Y』 C 『N』 AC 『N』 OV
<i>src M</i>	Shift right of memory with carry Example: <i>src MEM</i> ; Result: $MEM(c, b7, b6, b5, b4, b3, b2, b1) \leftarrow MEM(b7, b6, b5, b4, b3, b2, b1, b0)$, $C \leftarrow MEM(b0)$ Affected flags: 『N』 Z 『Y』 C 『N』 AC 『N』 OV
<i>sl a</i>	Shift left of ACC Example: <i>sl a</i> ; Result: $a(b6, b5, b4, b3, b2, b1, b0, 0) \leftarrow a(b7, b6, b5, b4, b3, b2, b1, b0)$, $C \leftarrow a(b7)$ Affected flags: 『N』 Z 『Y』 C 『N』 AC 『N』 OV
<i>slc a</i>	Shift left of ACC with carry Example: <i>slc a</i> ; Result: $a(b6, b5, b4, b3, b2, b1, b0, c) \leftarrow a(b7, b6, b5, b4, b3, b2, b1, b0)$, $C \leftarrow a(b7)$ Affected flags: 『N』 Z 『Y』 C 『N』 AC 『N』 OV
<i>sl M</i>	Shift left of memory Example: <i>sl MEM</i> ; Result: $MEM(b6, b5, b4, b3, b2, b1, b0, 0) \leftarrow MEM(b7, b6, b5, b4, b3, b2, b1, b0)$, $C \leftarrow MEM(b7)$ Affected flags: 『N』 Z 『Y』 C 『N』 AC 『N』 OV
<i>slc M</i>	Shift left of memory with carry Example: <i>slc MEM</i> ; Result: $MEM(b6, b5, b4, b3, b2, b1, b0, C) \leftarrow MEM(b7, b6, b5, b4, b3, b2, b1, b0)$, $C \leftarrow MEM(b7)$ Affected flags: 『N』 Z 『Y』 C 『N』 AC 『N』 OV
<i>swap a</i>	Swap the high nibble and low nibble of ACC Example: <i>swap a</i> ; Result: $a(b3, b2, b1, b0, b7, b6, b5, b4) \leftarrow a(b7, b6, b5, b4, b3, b2, b1, b0)$ Affected flags: 『N』 Z 『N』 C 『N』 AC 『N』 OV
<i>swap M</i>	Swap the high nibble and low nibble of memory Example: <i>swap MEM</i> ; Result: $MEM(b3, b2, b1, b0, b7, b6, b5, b4) \leftarrow MEM(b7, b6, b5, b4, b3, b2, b1, b0)$ Affected flags: 『N』 Z 『N』 C 『N』 AC 『N』 OV

7.4. Logic Operation Instructions

<i>and</i> a, I	Perform logic AND on ACC and immediate data, then put result into ACC Example: <i>and</i> a, 0x0f ; Result: $a \leftarrow a \& 0fh$ Affected flags: 『Y』 Z 『N』 C 『N』 AC 『N』 OV
<i>and</i> a, M	Perform logic AND on ACC and memory, then put result into ACC Example: <i>and</i> a, RAM10 ; Result: $a \leftarrow a \& RAM10$ Affected flags: 『Y』 Z 『N』 C 『N』 AC 『N』 OV
<i>and</i> M, a	Perform logic AND on ACC and memory, then put result into memory Example: <i>and</i> MEM, a ; Result: $MEM \leftarrow a \& MEM$ Affected flags: 『Y』 Z 『N』 C 『N』 AC 『N』 OV
<i>or</i> a, I	Perform logic OR on ACC and immediate data, then put result into ACC Example: <i>or</i> a, 0x0f ; Result: $a \leftarrow a 0fh$ Affected flags: 『Y』 Z 『N』 C 『N』 AC 『N』 OV
<i>or</i> a, M	Perform logic OR on ACC and memory, then put result into ACC Example: <i>or</i> a, MEM ; Result: $a \leftarrow a MEM$ Affected flags: 『Y』 Z 『N』 C 『N』 AC 『N』 OV
<i>or</i> M, a	Perform logic OR on ACC and memory, then put result into memory Example: <i>or</i> MEM, a ; Result: $MEM \leftarrow a MEM$ Affected flags: 『Y』 Z 『N』 C 『N』 AC 『N』 OV
<i>xor</i> a, I	Perform logic XOR on ACC and immediate data, then put result into ACC Example: <i>xor</i> a, 0x0f ; Result: $a \leftarrow a \wedge 0fh$ Affected flags: 『Y』 Z 『N』 C 『N』 AC 『N』 OV
<i>xor</i> a, IO	Perform logic XOR on ACC and IO register, then put result into ACC Example: <i>xor</i> a, pa ; Result: $a \leftarrow a \wedge pa$; // pa is the data register of port A Affected flags: 『Y』 Z 『N』 C 『N』 AC 『N』 OV
<i>xor</i> IO, a	Perform logic XOR on ACC and IO register, then put result into IO register Example: <i>xor</i> pa, a ; Result: $pa \leftarrow a \wedge pa$; // pa is the data register of port A Affected flags: 『N』 Z 『N』 C 『N』 AC 『N』 OV
<i>xor</i> a, M	Perform logic XOR on ACC and memory, then put result into ACC Example: <i>xor</i> a, MEM ; Result: $a \leftarrow a \wedge RAM10$ Affected flags: 『Y』 Z 『N』 C 『N』 AC 『N』 OV
<i>xor</i> M, a	Perform logic XOR on ACC and memory, then put result into memory Example: <i>xor</i> MEM, a ; Result: $MEM \leftarrow a \wedge MEM$ Affected flags: 『Y』 Z 『N』 C 『N』 AC 『N』 OV

<i>not</i> a	<p>Perform 1's complement (logical complement) of ACC</p> <p>Example: <i>not</i> a ;</p> <p>Result: a ← ~a</p> <p>Affected flags: 『Y』 Z 『N』 C 『N』 AC 『N』 OV</p> <p>Application Example:</p> <hr style="border-top: 1px dashed black;"/> <pre style="margin-left: 20px;"> mov a, 0x38 ; // ACC=0X38 not a ; // ACC=0XC7 </pre> <hr style="border-top: 1px dashed black;"/>
<i>not</i> M	<p>Perform 1's complement (logical complement) of memory</p> <p>Example: <i>not</i> MEM ;</p> <p>Result: MEM ← ~MEM</p> <p>Affected flags: 『Y』 Z 『N』 C 『N』 AC 『N』 OV</p> <p>Application Example:</p> <hr style="border-top: 1px dashed black;"/> <pre style="margin-left: 20px;"> mov a, 0x38 ; mov mem, a ; // mem = 0x38 not mem ; // mem = 0xC7 </pre> <hr style="border-top: 1px dashed black;"/>
<i>neg</i> a	<p>Perform 2's complement of ACC</p> <p>Example: <i>neg</i> a ;</p> <p>Result: a ← $\overline{\text{a}}$</p> <p>Affected flags: 『Y』 Z 『N』 C 『N』 AC 『N』 OV</p> <p>Application Example:</p> <hr style="border-top: 1px dashed black;"/> <pre style="margin-left: 20px;"> mov a, 0x38 ; // ACC=0X38 neg a ; // ACC=0XC8 </pre> <hr style="border-top: 1px dashed black;"/>
<i>neg</i> M	<p>Perform 2's complement of memory</p> <p>Example: <i>neg</i> MEM ;</p> <p>Result: MEM ← $\overline{\text{MEM}}$</p> <p>Affected flags: 『Y』 Z 『N』 C 『N』 AC 『N』 OV</p> <p>Application Example:</p> <hr style="border-top: 1px dashed black;"/> <pre style="margin-left: 20px;"> mov a, 0x38 ; mov mem, a ; // mem = 0x38 neg mem ; // mem = 0xC8 </pre> <hr style="border-top: 1px dashed black;"/>

<i>comp</i> a, I	<p>Compare ACC with immediate data</p> <p>Example: <i>comp</i> a, 0x55;</p> <p>Result: Flag will be changed by regarding as (a - 0x55)</p> <p>Affected flags: 『Y』 Z 『Y』 C 『Y』 AC 『Y』 OV</p> <p>Application Example:</p> <hr style="border-top: 1px dashed black;"/> <pre> mov a, 0x38 ; comp a, 0x38 ; // Z flag is set comp a, 0x42 ; // C flag is set comp a, 0x24 ; // C, Z flags are clear comp a, 0x6a ; // C, AC flags are set </pre> <hr style="border-top: 1px dashed black;"/>
<i>comp</i> a, M	<p>Compare ACC with the content of memory</p> <p>Example: <i>comp</i> a, MEM;</p> <p>Result: Flag will be changed by regarding as (a - MEM)</p> <p>Affected flags: 『Y』 Z 『Y』 C 『Y』 AC 『Y』 OV</p> <p>Application Example:</p> <hr style="border-top: 1px dashed black;"/> <pre> mov a, 0x38 ; mov mem, a ; comp a, mem ; // Z flag is set mov a, 0x42 ; mov mem, a ; mov a, 0x38 ; comp a, mem ; // C flag is set </pre> <hr style="border-top: 1px dashed black;"/>
<i>comp</i> M, a	<p>Compare ACC with the content of memory</p> <p>Example: <i>comp</i> MEM, a;</p> <p>Result: Flag will be changed by regarding as (MEM - a)</p> <p>Affected flags: 『Y』 Z 『Y』 C 『Y』 AC 『Y』 OV</p>

7.5. Bit Operation Instructions

<i>set0</i> IO.n	<p>Set bit n of IO port to low Example: <i>set0</i> pa.5 ; Result: set bit 5 of port A to low Affected flags: 『N』 Z 『N』 C 『N』 AC 『N』 OV</p>
<i>set1</i> IO.n	<p>Set bit n of IO port to high Example: <i>set1</i> pb.5 ; Result: set bit 5 of port B to high Affected flags: 『N』 Z 『N』 C 『N』 AC 『N』 OV</p>
<i>tog</i> IO.n	<p>Toggle bit state of bit n of IO port Example: <i>tog</i> pa.5 ; Result: toggle bit 5 of port A Affected flags: 『N』 Z 『N』 C 『N』 AC 『N』 OV</p>
<i>set0</i> M.n	<p>Set bit n of memory to low Example: <i>set0</i> MEM.5 ; Result: set bit 5 of MEM to low Affected flags: 『N』 Z 『N』 C 『N』 AC 『N』 OV</p>
<i>set1</i> M.n	<p>Set bit n of memory to high Example: <i>set1</i> MEM.5 ; Result: set bit 5 of MEM to high Affected flags: 『N』 Z 『N』 C 『N』 AC 『N』 OV</p>
<i>swapc</i> IO.n	<p>Swap the nth bit of IO port with carry bit Example: <i>swapc</i> IO.0; Result: C ← IO.0 , IO.0 ← C When IO.0 is a port to output pin, carry C will be sent to IO.0; When IO.0 is a port from input pin, IO.0 will be sent to carry C; Affected flags: 『N』 Z 『Y』 C 『N』 AC 『N』 OV Application Example (serial output) :</p> <hr style="border-top: 1px dashed black;"/> <pre> ... set1 pac.0 ; // set PA.0 as output ... set0 flag.1 ; // C=0 swapc pa.0 ; // move C to PA.0 (bit operation), PA.0=0 set1 flag.1 ; // C=1 swapc pa.0 ; // move C to PA.0 (bit operation), PA.0=1 ... </pre> <hr style="border-top: 1px dashed black;"/>

7.6. Conditional Operation Instructions

<i>ceqsn</i> a, l	<p>Compare ACC with immediate data and skip next instruction if both are equal. Flag will be changed like as $(a \leftarrow a - l)$ Example: <i>ceqsn</i> a, 0x55 ; <i>inc</i> MEM ; <i>goto</i> error ;</p> <p>Result: If a=0x55, then “goto error”; otherwise, “inc MEM”. Affected flags: 『Y』 Z 『Y』 C 『Y』 AC 『Y』 OV</p>
<i>ceqsn</i> a, M	<p>Compare ACC with memory and skip next instruction if both are equal. Flag will be changed like as $(a \leftarrow a - M)$ Example: <i>ceqsn</i> a, MEM; Result: If a=MEM, skip next instruction Affected flags: 『Y』 Z 『Y』 C 『Y』 AC 『Y』 OV</p>
<i>ceqsn</i> M, a	<p>Compare ACC with memory and skip next instruction if both are equal. Example: <i>ceqsn</i> MEM, a; Result: If a=MEM, skip next instruction Affected flags: 『Y』 Z 『Y』 C 『Y』 AC 『Y』 OV</p>
<i>cneqsn</i> a, M	<p>Compare ACC with memory and skip next instruction if both are not equal. Flag will be changed like as $(a \leftarrow a - M)$ Example: <i>cneqsn</i> a, MEM; Result: If a≠MEM, skip next instruction Affected flags: 『Y』 Z 『Y』 C 『Y』 AC 『Y』 OV</p>
<i>cneqsn</i> M, a	<p>Compare memory with ACC and skip next instruction if both are not equal. Flag will be changed like as $(M \leftarrow M - a)$ Example: <i>cneqsn</i> MEM, a; Result: If a≠MEM, skip next instruction Affected flags: 『Y』 Z 『Y』 C 『Y』 AC 『Y』 OV</p>
<i>cneqsn</i> a, l	<p>Compare ACC with immediate data and skip next instruction if both are no equal. Flag will be changed like as $(a \leftarrow a - l)$ Example: <i>cneqsn</i> a, 0x55 ; <i>inc</i> MEM ; <i>goto</i> error ;</p> <p>Result: If a≠0x55, then “goto error”; Otherwise, “inc MEM”. Affected flags: 『Y』 Z 『Y』 C 『Y』 AC 『Y』 OV</p>
<i>t0sn</i> IO.n	<p>Check IO bit and skip next instruction if it's low Example: <i>t0sn</i> pa.5; Result: If bit 5 of port A is low, skip next instruction Affected flags: 『N』 Z 『N』 C 『N』 AC 『N』 OV</p>
<i>t1sn</i> IO.n	<p>Check IO bit and skip next instruction if it's high Example: <i>t1sn</i> pa.5 ; Result: If bit 5 of port A is high, skip next instruction Affected flags: 『N』 Z 『N』 C 『N』 AC 『N』 OV</p>

<i>t0sn</i> M.n	<p>Check memory bit and skip next instruction if it's low Example: <i>t0sn</i> MEM.5 ; Result: If bit 5 of MEM is low, then skip next instruction Affected flags: 『N』 Z 『N』 C 『N』 AC 『N』 OV</p>
<i>t1sn</i> M.n	<p>Check memory bit and skip next instruction if it's high EX: <i>t1sn</i> MEM.5 ; Result: If bit 5 of MEM is high, then skip next instruction Affected flags: 『N』 Z 『N』 C 『N』 AC 『N』 OV</p>
<i>izsn</i> a	<p>Increment ACC and skip next instruction if ACC is zero Example: <i>izsn</i> a; Result: $a \leftarrow a + 1$, skip next instruction if $a = 0$ Affected flags: 『Y』 Z 『Y』 C 『Y』 AC 『Y』 OV</p>
<i>dzsn</i> a	<p>Decrement ACC and skip next instruction if ACC is zero Example: <i>dzsn</i> a; Result: $A \leftarrow A - 1$, skip next instruction if $a = 0$ Affected flags: 『Y』 Z 『Y』 C 『Y』 AC 『Y』 OV</p>
<i>izsn</i> M	<p>Increment memory and skip next instruction if memory is zero Example: <i>izsn</i> MEM; Result: $MEM \leftarrow MEM + 1$, skip next instruction if $MEM = 0$ Affected flags: 『Y』 Z 『Y』 C 『Y』 AC 『Y』 OV</p>
<i>dzsn</i> M	<p>Decrement memory and skip next instruction if memory is zero Example: <i>dzsn</i> MEM; Result: $MEM \leftarrow MEM - 1$, skip next instruction if $MEM = 0$ Affected flags: 『Y』 Z 『Y』 C 『Y』 AC 『Y』 OV</p>
<i>wait0</i> IO.n	<p>Go next instruction until bit n of IO port is low, otherwise, wait here. Example: <i>wait0</i> pa.5; Result: Wait bit 5 of port A low to execute next instruction; Affected flags: 『N』 Z 『N』 C 『N』 AC 『N』 OV Note: This instruction is not supported in single FPP mode.</p>
<i>wait1</i> IO.n	<p>Go next instruction until bit n of IO port is high, otherwise, wait here. Example: <i>wait1</i> pa.5; Result: Wait bit 5 of port A high to execute next instruction; Affected flags: 『N』 Z 『N』 C 『N』 AC 『N』 OV Note: This instruction is not supported in single FPP mode.</p>

7.7. System control Instructions

<i>call</i> label	<p>Function call, address can be full range address space</p> <p>Example: <i>call</i> function1;</p> <p>Result: [sp] ← pc + 1 pc ← function1 sp ← sp + 2</p> <p>Affected flags: 『N』 Z 『N』 C 『N』 AC 『N』 OV</p>
<i>goto</i> label	<p>Go to specific address which can be full range address space</p> <p>Example: <i>goto</i> error;</p> <p>Result: Go to error and execute program.</p> <p>Affected flags: 『N』 Z 『N』 C 『N』 AC 『N』 OV</p>
<i>delay</i> I	<p>Delay the (N + 1) cycles which N is specified by the immediate data, the timing is based on the executing FPP unit. After the <i>delay</i> instruction is executed, the ACC will be zero.</p> <p>Example: <i>delay</i> 0x05;</p> <p>Result: Delay 6 cycles here</p> <p>Affected flags: 『N』 Z 『N』 C 『N』 AC 『N』 OV</p> <p>Notes:</p> <ol style="list-style-type: none"> (1) Because ACC is the temporarily buffer for counting, please make sure that it will not be interrupted when executing this instruction. Otherwise, it may be not the expected delay time. (2) <u>This instruction is not supported in single FPP mode.</u>
<i>delay</i> a	<p>Delay the (N + 1) cycles which N is specified by the content of ACC, the timing is based on the executing FPP unit. After the <i>delay</i> instruction is executed, the ACC will be zero.</p> <p>Example: <i>delay</i> a;</p> <p>Result: Delay 16 cycles here if ACC=0fh</p> <p>Affected flags: 『N』 Z 『N』 C 『N』 AC 『N』 OV</p> <p>Notes:</p> <ol style="list-style-type: none"> (1) Because ACC is the temporarily buffer for counting, please make sure that it will not be interrupted when executing this instruction. Otherwise, it may be not the expected delay time. (2) <u>This instruction is not supported in single FPP mode.</u>
<i>delay</i> M	<p>Delay the (N + 1) cycles which N is specified by the content of memory, the timing is based on the executing FPP unit. After the <i>delay</i> instruction is executed, the ACC will be zero.</p> <p>Example: <i>delay</i> M;</p> <p>Result: Delay 256 cycles here if M=ffh</p> <p>Affected flags: 『N』 Z 『N』 C 『N』 AC 『N』 OV</p> <p>Notes:</p> <ol style="list-style-type: none"> (1) Because ACC is the temporarily buffer for counting, please make sure that it will not be interrupted when executing this instruction. Otherwise, it may be not the expected delay time. (2) <u>This instruction is not supported in single FPP mode.</u>
<i>ret</i> I	<p>Place immediate data to ACC, then return</p> <p>Example: <i>ret</i> 0x55;</p> <p>Result: A ← 55h ret ;</p> <p>Affected flags: 『N』 Z 『N』 C 『N』 AC 『N』 OV</p>

<i>ret</i>	<p>Return to program which had function call</p> <p>Example: <i>ret</i>;</p> <p>Result: <code>sp ← sp - 2</code> <code>pc ← [sp]</code></p> <p>Affected flags: 『N』 Z 『N』 C 『N』 AC 『N』 OV</p>
<i>reti</i>	<p>Return to program that is interrupt service routine. After this command is executed, global interrupt is enabled automatically.</p> <p>Example: <i>reti</i>;</p> <p>Affected flags: 『N』 Z 『N』 C 『N』 AC 『N』 OV</p>
<i>nop</i>	<p>No operation</p> <p>Example: <i>nop</i>;</p> <p>Result: nothing changed</p> <p>Affected flags: 『N』 Z 『N』 C 『N』 AC 『N』 OV</p>
<i>pcadd a</i>	<p>Next program counter is current program counter plus ACC.</p> <p>Example: <i>pcadd a</i>;</p> <p>Result: <code>pc ← pc + a</code></p> <p>Affected flags: 『N』 Z 『N』 C 『N』 AC 『N』 OV</p> <p>Application Example:</p> <pre> ----- ... mov a, 0x02 ; pcadd a ; // PC <- PC+2 goto err1 ; goto correct ; // jump here goto err2 ; goto err3 ; ... correct: // jump here ... ----- </pre>
<i>engint</i>	<p>Enable global interrupt enable</p> <p>Example: <i>engint</i>;</p> <p>Result: Interrupt request can be sent to FPP0</p> <p>Affected flags: 『N』 Z 『N』 C 『N』 AC 『N』 OV</p>
<i>disgint</i>	<p>Disable global interrupt enable</p> <p>Example: <i>disgint</i>;</p> <p>Result: Interrupt request is blocked from FPP0</p> <p>Affected flags: 『N』 Z 『N』 C 『N』 AC 『N』 OV</p>

<i>stopsys</i>	<p>System halt.</p> <p>Example: <i>stopsys</i>;</p> <p>Result: Stop the system clocks and halt the system</p> <p>Affected flags: 『N』 Z 『N』 C 『N』 AC 『N』 OV</p>
<i>stopexe</i>	<p>CPU halt. The oscillator module is still active to output clock, however, system clock is disabled to save power.</p> <p>Example: <i>stopexe</i>;</p> <p>Result: Stop the system clocks and keep oscillator modules active.</p> <p>Affected flags: 『N』 Z 『N』 C 『N』 AC 『N』 OV</p>
<i>reset</i>	<p>Reset the whole chip, its operation will be same as hardware reset.</p> <p>Example: <i>reset</i>;</p> <p>Result: Reset the whole chip.</p> <p>Affected flags: 『N』 Z 『N』 C 『N』 AC 『N』 OV</p>
<i>wdreset</i>	<p>Reset Watchdog timer.</p> <p>Example: <i>wdreset</i> ;</p> <p>Result: Reset Watchdog timer.</p> <p>Affected flags: 『N』 Z 『N』 C 『N』 AC 『N』 OV</p>

7.8. Summary of Instructions Execution Cycle

2T	<i>jump, call, ceqsn, cneqsn, t0sn, t1sn, dzsn, izsn, ldtabh, ldtabl, idxm</i>
1T	Others

7.9. Summary of affected flags by Instructions

Instruction	Z	C	AC	OV	Instruction	Z	C	AC	OV	Instruction	Z	C	AC	OV
<i>mov a, l</i>	-	-	-	-	<i>mov M, a</i>	-	-	-	-	<i>mov a, M</i>	Y	-	-	-
<i>mov a, IO</i>	Y	-	-	-	<i>mov IO, a</i>	-	-	-	-	<i>nmov M, a</i>	-	-	-	-
<i>nmov a, M</i>	Y	-	-	-	<i>ldtabh index</i>	-	-	-	-	<i>ldtabl index</i>	-	-	-	-
<i>ldt16 index</i>	-	-	-	-	<i>stt16 index</i>					<i>xch M</i>	-	-	-	-
<i>idxm a, index</i>	-	-	-	-	<i>idxm index, a</i>	-	-	-	-	<i>wdreset</i>	-	-	-	-
<i>pushaf</i>	-	-	-	-	<i>popaf</i>	Y	Y	Y	Y	<i>add a, l</i>	Y	Y	Y	Y
<i>add a, M</i>	Y	Y	Y	Y	<i>add M, a</i>	Y	Y	Y	Y	<i>addc a, M</i>	Y	Y	Y	Y
<i>addc M, a</i>	Y	Y	Y	Y	<i>addc a</i>	Y	Y	Y	Y	<i>addc M</i>	Y	Y	Y	Y
<i>nadd a, M</i>	Y	Y	Y	Y	<i>nadd M, a</i>	Y	Y	Y	Y	<i>sub a, l</i>	Y	Y	Y	Y
<i>sub a, M</i>	Y	Y	Y	Y	<i>sub M, a</i>	Y	Y	Y	Y	<i>subc a, M</i>	Y	Y	Y	Y
<i>subc M, a</i>	Y	Y	Y	Y	<i>subc a</i>	Y	Y	Y	Y	<i>subc M</i>	Y	Y	Y	Y
<i>inc M</i>	Y	Y	Y	Y	<i>dec M</i>	Y	Y	Y	Y	<i>clear M</i>	-	-	-	-
<i>sr a</i>	-	Y	-	-	<i>src a</i>	-	Y	-	-	<i>sr M</i>	-	Y	-	-
<i>src M</i>	-	Y	-	-	<i>sl a</i>	-	Y	-	-	<i>slc a</i>	-	Y	-	-
<i>sl M</i>	-	Y	-	-	<i>slc M</i>	-	Y	-	-	<i>swap a</i>	-	-	-	-
<i>swap M</i>	-	-	-	-	<i>and a, l</i>	Y	-	-	-	<i>and a, M</i>	Y	-	-	-
<i>and M, a</i>	Y	-	-	-	<i>or a, l</i>	Y	-	-	-	<i>or a, M</i>	Y	-	-	-
<i>or M, a</i>	Y	-	-	-	<i>xor a, l</i>	Y	-	-	-	<i>xor a, M</i>	Y	-	-	-
<i>xor M, a</i>	Y	-	-	-	<i>xor a, IO</i>	Y	-	-	-	<i>xor IO, a</i>	-	-	-	-
<i>not a</i>	Y	-	-	-	<i>not M</i>	Y	-	-	-	<i>neg a</i>	Y	-	-	-
<i>neg M</i>	Y	-	-	-	<i>comp a, l</i>	Y	Y	Y	Y	<i>comp a, M</i>	Y	Y	Y	Y
<i>comp M, a</i>	Y	Y	Y	Y	<i>set0 IO.n</i>	-	-	-	-	<i>set1 IO.n</i>	-	-	-	-
<i>tog IO.n</i>	-	-	-	-	<i>set0 M.n</i>	-	-	-	-	<i>set1 M.n</i>	-	-	-	-
<i>swapc IO.n</i>	-	Y	-	-	<i>ceqsn a, l</i>	Y	Y	Y	Y	<i>ceqsn a, M</i>	Y	Y	Y	Y
<i>ceqsn M, a</i>	Y	Y	Y	Y	<i>cneqsn a, l</i>	Y	Y	Y	Y	<i>cneqsn a, M</i>	Y	Y	Y	Y
<i>cneqsn M, a</i>	Y	Y	Y	Y	<i>t0sn IO.n</i>	-	-	-	-	<i>t1sn IO.n</i>	-	-	-	-
<i>t0sn M.n</i>	-	-	-	-	<i>t1sn M.n</i>	-	-	-	-	<i>izsn a</i>	Y	Y	Y	Y
<i>dzsn a</i>	Y	Y	Y	Y	<i>izsn M</i>	Y	Y	Y	Y	<i>dzsn M</i>	Y	Y	Y	Y
<i>wait0 IO.n</i>	-	-	-	-	<i>wait1 IO.n</i>	-	-	-	-	<i>call label</i>	-	-	-	-
<i>goto label</i>	-	-	-	-	<i>delay a</i>	-	-	-	-	<i>delay l</i>	-	-	-	-
<i>delay M</i>	-	-	-	-	<i>ret l</i>	-	-	-	-	<i>ret</i>	-	-	-	-
<i>reti</i>	-	-	-	-	<i>nop</i>	-	-	-	-	<i>pcadd a</i>	-	-	-	-
<i>engint</i>	-	-	-	-	<i>disgint</i>	-	-	-	-	<i>stopsys</i>	-	-	-	-
<i>reset</i>	-	-	-	-	<i>stopexe</i>	-	-	-	-					

8. Special Notes

This chapter is to remind user who use PMC271/PMS271 series IC in order to avoid frequent errors upon operation.

8.1. Using IC

8.1.1. IO pin usage and setting

(1) IO pin as analog input

- ◆ Configure IO pin as input
- ◆ Set PADIER and PBDIER registers to configure corresponding IO as analog input
- ◆ Set PAPH and PBPH registers to disable corresponding IO pull-up resistor
- ◆ The functions of PADIER and PBDIER registers of PMC271/PMS271 series IC is contrary to ICE functions. **Please use following program in order to keep ICE emulation consisting with PMC271/PMS271 series IC procedure.**

```
$ PADIER 0xF0;  
$ PBDIER 0x0F;
```

(2) PA5 as input pin

PA5 can only be Open-Drain output pin. Output high requires adding pull-up resistor

(3) PA5 as PRST# input

- ◆ No internal pull-up resistor for PA5
- ◆ Configure PA5 as input
- ◆ Set CLKMD.0=1 to enable PA5 as PRST# input pin

(4) PA4/PA5 as input pin to connect with a push button or a switch by a long wire

- ◆ Needs to put a >10Ω resistor in between PA4/PA5 and the long wire
- ◆ **Avoid using PA5 as input**

(5) PA7 and PA6 as external crystal oscillator pin

- ◆ Configure PA7 and PA6 as input
- ◆ Disable PA7 and PA6 internal pull-up resistor
- ◆ Configure PADIER register to set PA6 and PA7 as analog input
- ◆ EOSCR register bit [6:5] selects corresponding crystal oscillator frequency :
 - ◇ 01 : for lower frequency, ex : 32kHz
 - ◇ 10 : for middle frequency, ex : 455kHz、 1MHz
 - ◇ 11 : for higher frequency, ex : 4MHz
- ◆ Program EOSCR.7 =1 to enable crystal oscillator
- ◆ Ensure EOSC working well before switching from IHRC or ILRC to EOSC. Refer to **8.1.3.(2)**

8.1.2. Interrupt

(1) When using the interrupt function, the procedure should be:

Step1: Set INTEN register, enable the interrupt control bit

Step2: Clear INTRQ register

Step3: In the main program, using ENGINT to enable CPU interrupt function

Step4: Wait for interrupt. When interrupt occurs, enter to Interrupt Service Routine

Step5: After the Interrupt Service Routine being executed, return to the main program

* Use DISGINT in the main program to disable all interrupts

* When interrupt service routine starts, use PUSHAF instruction to save ALU and FLAG register. POPAF instruction is to restore ALU and FLAG register before RETI as below:

```
void Interrupt (void) // Once the interrupt occurs, jump to interrupt service routine
{
    // enter DISGINT status automatically, no more interrupt is
    accepted
    PUSHAF;
    ...
    POPAF;
} // RETI will be added automatically. After RETI being executed, ENGINT status
will be restored
```

(2) INTEN and INTRQ have no initial values. Please set required value before enabling interrupt function

(3) FPPA1 will not be affected by interrupt at all

8.1.3. System clock switching

(1) System clock can be switched by CLKMD register. Please notice that, **NEVER switch the system clock and turn off the original clock source at the same time**. For example: When switching from clock A to clock B, please switch to clock B first; and after that turn off the clock A oscillator through CLKMD.

◆ Case 1 : Switch system clock from ILRC to IHRC/2

```
CLKMD = 0x36; // switch to IHRC, ILRC can not be disabled here
```

```
CLKMD.2 = 0; // ILRC can be disabled at this time
```

◆ Case 2 : Switch system clock from ILRC to EOSC

```
CLKMD = 0xA6; // switch to EOSC, ILRC can not be disabled here
```

```
CLKMD.2 = 0; // ILRC can be disabled at this time
```

◆ **ERROR.** Switch ILRC to IHRC and turn off ILRC simultaneously

```
CLKMD = 0x50; // MCU will hang
```

- (2) Please ensure the EOSC oscillation has established before switching from ILRC or IHRC to EOSC. MCU will not check its status. Please wait for a while after enabling EOSC. System clock can be switched to EOSC afterwards. Otherwise, MCU will hang. The example for switching system clock from ILRC to 4MHz EOSC after boot up as below:

```
.ADJUST_IC  DISABLE
CLKMD.1 = 0;           // turn off WDT for executing delay instruction.
$ EOSCR  Enable, 4MHz; // 4MHz EOSC start to oscillate.
delay 255              // Delay for EOSC establishment
CLKMD  = 0xA4;        // ILRC -> EOSC;
CLKMD.2 = 0;         // turn off ILRC only if necessary
```

The delay duration should be adjusted in accordance with the characteristic of the crystal and PCB. To measure the oscillator signal by the oscilloscope, please select (x10) on the probe and measure through PA6(X2) pin to avoid the interference on the oscillator.

8.1.4. Power down mode, wakeup and watchdog

- (1) Watchdog will be inactive once ILRC is disabled
- (2) Please turn off watchdog before executing STOPSYS or STOPEXE instruction, otherwise IC will be reset due to watchdog timeout. It is the same as in ICE emulation.
- (3) The clock source of Watchdog is ILRC if the fast wakeup is disabled; otherwise, **the clock source of Watchdog will be the system clock and the reset time becomes much shorter**. It is recommended to disable Watchdog and enable fast wakeup before entering STOPSYS mode. When the system is waken up from power down mode, please firstly disable fast wakeup function, and then enable Watchdog. It is to avoid system to be reset after being waken up.
- (4) If enable Watchdog during programming and also wants the fast wakeup, the example as below:

```
CLKMD.En_WatchDog  = 0;           // disable watchdog timer
$ MISC  Fast_Wake_Up;
stopexe;
nop;
$ MISC  WT_xx;                // Reset Watchdog time to normal wake-up
Wdreset;
CLKMD.En_WatchDog  = 1;           // enable watchdog timer
```

8.1.5. TIMER time out

When select T16M counter BIT8 as 1 to generate interrupt, the first interrupt will occur when the counter reaches to 0x100 (BIT8 from 0 to 1) and the second interrupt will occur when the counter reaches 0x300 (BIT8 from 0 to 1) . Therefore, selecting BIT8 as 1 to generate interrupt means that the interrupt occurs every 512 counts. Please notice that if T16M counter is restarted, the next interrupt will occur once Bit8 turns from 0 to 1.

8.1.6. Using ADC

- (1) Configure corresponding IO as input through PXDIER register
- (2) The recommended highest ADC conversion frequency is 500kHz and maximum output impedance of analog signal source is 15KΩ.
- (3) Never restart next conversion before completion of last ADC conversion; otherwise, wrong value would get.
- (4) Please pay attention on sequence of operation if the program fits for below conditions,
 1. Use the FPP (ex. FPPA0) for handling power-save mode to disable ADC.
 2. Use the FPP (ex. FPPA1) for handling ADC conversion to enable ADC and wait for completion of ADC conversion with **WAIT1 ADC_Done** instruction.
 3. Execute above **【1】** & **【2】** simultaneously

In case the above sequence is not properly arranged, there may be a chance that FPPA1 can not pass through **WAIT1 ADC_Done** instruction because the ADC may be disabled by FPPA0 before **WAIT1 ADC_Done** instruction being executed.

Recommendation:

Define a Flag which represents the operation of ADC. Every time FPPA1 set the flag when enable the ADC and reset it when the completion of ADC conversion. FPPA0 checks this flag and decides to enter power-save and disable ADC if it is reset.

8.1.7. LVR

- (1) VDD must reach or above 2.2V for successful power-on process; otherwise IC will be inactive.
- (2) The setting of LVR (1.8V, 2.0V, 2.2V etc) will be valid just after successful power-on process.

8.1.8. Differences in command timing between single / double FPPA mode

Differences on PMC271/PMS271 series instruction cycle

Instruction	Condition	1 FPPA	2 FPPA
goto, call		2T	1T
ceqsn, cneqsn, t0sn, t1sn, dzsn, izsn	Condition is fulfilled	2T	1T
	Condition is not fulfilled	1T	1T
ldtabh, ldtabl, idxm		2T	2T
Others		1T	1T

8.1.9. Program writing

PMC271/PMS271 8pin packages: Put the jumper over the PDK22C10 location, and put the IC 1 pin downwards on the socket.

PMC271/PMS271 other packages: Put the jumper over the PDK22C13 location, and put the IC at the top location of the socket

8.2. Using ICE

8.2.1. Emulating PMC271/PMS271 series IC on ICE PDK3S-I-001/002/003

PMC271/PMS271 series I/O pin is defined as compatible with PDK22C series. When user use ICE PDK3S-I-001/002/003 to emulate PMC271/PMS271 series IC, please connect the cable labeled CN12 or CN17 with CN12 or CN17 connectors on PDK3S-I-001/002/003 by matching each assembled pins respectively.

- (1) Emulating PMC271/PMS271(SOP14) : Use cable labeled CN17:P211CS14/CD14 to connect CN17 connector on PDK3S-I-001/002/003. Connection is shown in illustration 1-1.
- (2) Emulating PMC271/PMS271(SOP16/SSOP16) : Use cable labeled CN17:PDK82C12, PDK82C16 to connect CN 17 connector on PDK3S-I-001/002/003. Connection is shown in illustration 1-1.
- (3) Emulating PMC271/PMS271(SOP18) : Use cable labeled CN17:PDK82C15, P221CS18/CD18 to connect CN 17 connector on PDK3S-I-001/002/003. Connection is shown in illustration 1-1.

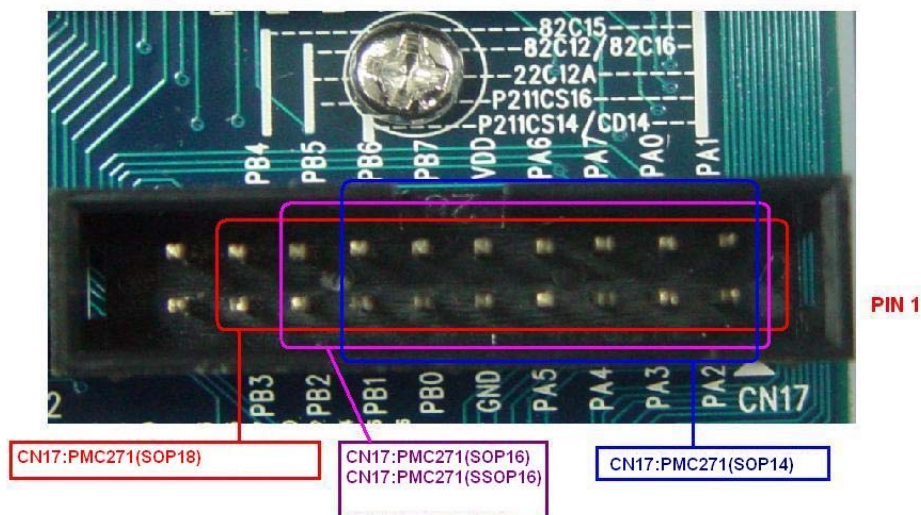

- (4) Emulating PMC271/PMS271(SSOP20/DIP20) : Use cable labeled CN12:82C13-D to connect CN12 connector on PDK3S-I-001/002/003. Connection is shown in illustration 1-2

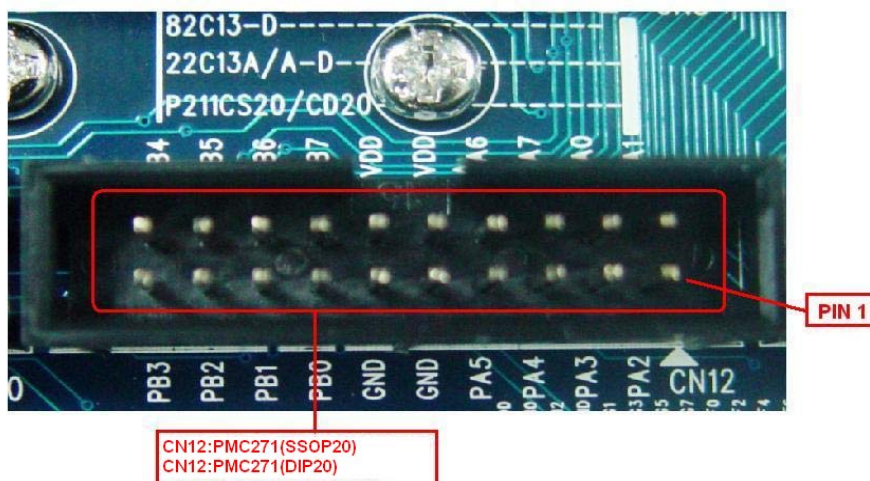

8.2.2. Important Notice for ICE operation

- (1) EV3-0101D-CON ICE board is required when emulate PMC271/PMS271 series IC LCD 1/2 VDD function. Details please refer to “ PDK3S-I-001/002/003 ICE user’s manual” section 8.

- (2) ICE PDK3S-I-001/001/002 does not support emulating below PMC271/PMS271 series IC functions from (a) to (k). Thus, user needs to take PMC271/PMS271 Real Chip for test. Please notice : In order to avoid the problems on difference between ICE and Real Chip test procedure, those functions will be temporarily removed from datasheet before ICE is set to support them. PMC271/PMS271 Real Chip is defaulted with these functions and performing ordinarily. Please refer to V0.08 datasheet. Customer is recommended to consider these exceptions and careful handle whenever doing the test.
 - (a) PMC271/PMS271 series IC is able to set Band-Gap voltage as ADC reference voltage (Vref).
 - (b) PMC271/PMS271 series IC is able to set Band-Gap voltage output to PB2.
 - (c) PMC271/PMS271 series IC is able to set LVD minimum to 1.8V, 8 stages at all 4.0V, 3.5V, 3.0V, 2.75V, 2.5V, 2.2V, 2.0V, 1.8V.
 - (d) PMC271/PMS271 series IC LVD function can be disabled by register (misc.2).
 - (e) PMC271/PMS271 series IC is able to support LVD reset and fast-recover by register (misc.3).
 - (f) PMC271/PMS271 series IC is able to output voltage from PB1 I/O pin to PB2.
 - (g) PMC271/PMS271 series IC is able to be set as single core operating model.
 - (h) PMC271/PMS271 series IC supports VDD less than 4V, 3V, 2V voltage level detection and store detecting result to internal register (rstst).
 - (i) PMC271/PMS271 series IC support reset-source detection.
 - (j) PMC271/PMS271 series IC Timer 16 Clock Source supports external PA4 signal input.
 - (k) PMC271/PMS271 series IC provides watch-dog time out function which is assigned by register misc[1:0]

X-ON Electronics

Largest Supplier of Electrical and Electronic Components

Click to view similar products for [Microprocessors - MPU category](#):

Click to view products by [PADAUK manufacturer](#):

Other Similar products are found below :

[MC68302EH20C](#) [MC7457RX1000LC](#) [MC7457RX1267LC](#) [MC7457VG1267LC](#) [A2C00010998 A](#) [A2C52004004](#) [R5F117BCGNA#20](#)
[R5F52106BDLA#U0](#) [R5S72690W266BG#U0](#) [ADJ3400IAA5DOE](#) [MPC8245TVV266D](#) [MPC8245TZU300D](#) [MPC8260ACVVMHBB](#)
[MPC8323ECVRAFDCA](#) [MPC8536ECVJAVLA](#) [BOXNUC5PGYH0AJ](#) [20-668-0024](#) [P1010NSN5DFB](#) [P2010NSN2MHC](#) [P2020NXE2HHC](#)
[P5020NSE7QMB](#) [P5020NSE7TNB](#) [P5020NSE7VNB](#) [LS1020ASN7KQB](#) [LS1020AXN7HNB](#) [LS1020AXN7KQB](#) [A2C00010729 A](#)
[A2C00039344](#) [T1022NSE7MQB](#) [T1022NXN7PQB](#) [T1023NSE7MQA](#) [T1024NXE7PQA](#) [T1042NSE7MQB](#) [T1042NSN7MQB](#)
[T1042NXN7WQB](#) [T2080NSE8TTB](#) [T2080NSN8PTB](#) [T2080NXE8TTB](#) [T2081NXN8TTB](#) [R5F101AFASP#V0](#) [MC68302CEH20C](#)
[TS68040MF33A](#) [MPC8260ACVVMIBB](#) [MPC8280CZUPEA](#) [MPC8313ECVRAFFC](#) [MPC8313ECVRAGDC](#) [MPC8313EVRADDC](#)
[MPC8313EVRAFFC](#) [MPC8313VRADDC](#) [MPC8314CVRAGDA](#)