



## General Description

The DSC8001 is a programmable silicon MEMS based CMOS oscillator offering excellent jitter and stability performance over a wide range of supply voltages and temperatures. The device operates from 1 to 150MHz in increments of 100Hz (up to four decimal point resolution) with supply voltages between 1.8 to 3.3 Volts and extended temperatures from -40°C to 105°C.

The DSC8001 incorporates an all silicon resonator that is extremely robust and nearly immune to stress related fractures, common to crystal based oscillators. Without sacrificing the performance and stability required of today's systems, a crystal-less design allows for a higher level of reliability, making the DSC8001 ideal for rugged, industrial, and portable applications where stress, shock, and vibration can damage quartz crystal based systems.

Available in industry standard packages, the DSC8001 can be "dropped-in" to the same PCB footprint as standard crystal oscillators.

## Block Diagram

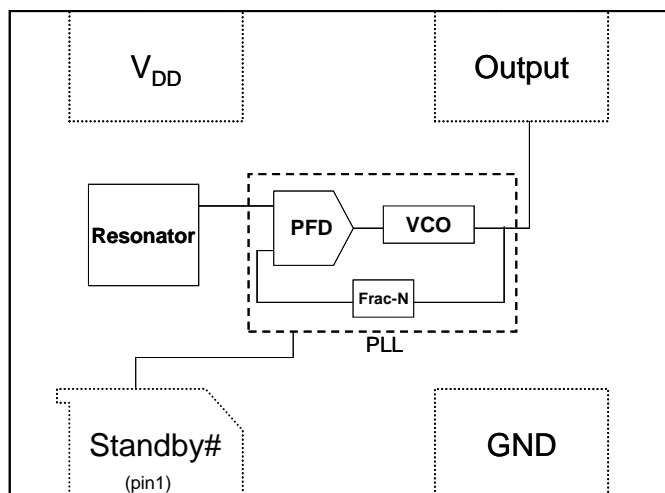

## Features

- Frequency Range: 1 to 150MHz
- Exceptional Stability over Temperature
  - ±10 PPM, ±25 PPM, ±50 PPM
- Operating voltage
  - 1.7 to 3.6V
- Operating Temperature Range
  - Ext. Industrial -40°C to 105°C
  - Industrial -40°C to 85°C
  - Ext. Commercial -20°C to 70°C
  - Commercial 0°C to 70°C
- Low Operating and Standby Current
  - 5mA Operating (40MHz)
  - 15uA Standby
- Ultra Miniature Footprint
  - 2.5 x 2.0 x 0.85 mm
  - 3.2 x 2.5 x 0.85 mm
  - 5.0 x 3.2 x 0.85 mm
  - 7.0 x 5.0 x 0.85 mm
- MIL-STD 883 Shock and Vibration Resistant
- Pb Free, RoHS, Reach SVHC Compliant
- AEC-Q100 Reliability Qualified

## Benefits

- Pin for pin "drop in" replacement for industry standard oscillators
- Semiconductor level reliability, significantly higher than quartz
- Frequency Resolution to 4 decimals
- Short mass production lead-times
- Longer Battery Life / Reduced Power
- Compact Plastic package
- Cost Effective

## Applications

- Mobile Applications
- Consumer Electronics
- Portable Electronics
- DVR, CCTV, Surveillance Cameras
- Low Profile Applications
- Industrial Applications

## Absolute Maximum Ratings<sup>1</sup>

Item	Min.	Max	Unit	Condition
Supply Voltage	-0.3	+4.0	V	
Input Voltage	-0.3	VDD+0.3	V	
Junction Temp	-	+150	°C	
Storage Temp	-55	+150	°C	
Soldering Temp	-	+260	°C	40 sec max.
ESD	-		V	
HBM		4000		
MM		200		
CDM		1500		

## Ordering Code

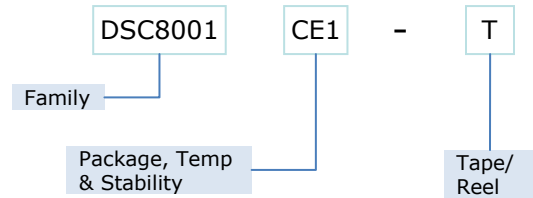

\* See Ordering Information for details

## Recommended Operating Conditions

Parameter	Symbol	Range
Supply Voltage	$V_{DD}$	1.71 – 3.60V
Output Load	$Z_L$	$R > 10K\Omega$ , $C \leq 15pF$
Operating Temperature		
Option 1	T	-40 to +105 °C
Option 2		-40 to +85 °C
Option 3		-20 to +70 °C
Option 4		0 to +70 °C

## Specifications (VDD = 1.8 to 3.3v) $T_A = 85^\circ C$ unless otherwise specified

Parameter	Symbol	Condition	Min	Typ	Max	Unit
Frequency	$f_0$	Single Frequency	1		150	MHz
Frequency Tolerance	$\Delta f$	Includes frequency variations due to initial tolerance, temperature and power supply voltage			$\pm 10, \pm 25, \pm 50$	ppm
Aging	$\Delta f$	1 year @25°C			$\pm 5$	ppm
Supply Current, standby	$I_{DD}$	T=25°C			15	uA
Output Logic Levels						
Output logic high	$V_{OH}$	-4mA	$0.8 * V_{DD}$		-	Volts
Output logic low	$V_{OL}$	4mA	-		$0.2 * V_{DD}$	
Output Startup Time <sup>2</sup>	$t_{SU}$	T=25°C		1.0	1.3	ms
Output Disable Time	$t_{DA}$			20	100	ns
Output Duty Cycle	SYM		45		55	%
Input Logic Levels						
Input logic high	$V_{IH}$		$0.75 * V_{DD}$		-	Volts
Input logic low	$V_{IL}$		-		$0.25 * V_{DD}$	

**VDD = 1.8v**

Parameter	Symbol	Condition		Min	Typ	Max	Unit
Supply Current, no load	$I_{DD}$	$C_L=0p$ $R_L=\infty$ $T=25^\circ C$	1MHz		6.0	6.3	mA
			27MHz		6.5	6.9	
			70MHz		7.2	7.5	
			150MHz		8.3	9.1	
Output Transition time		$C_L=15pF; T=25^\circ C$					
Rise Time	$t_R$	$20\%/80\%*V_{DD}$			1.8	3	ns
Fall Time	$t_F$				1.0	3	
Jitter, Max Cycle to Cycle	$J_{CC}$	$F = 100MHz^3$			60		Ps

**VDD = 2.5v**

Parameter	Symbol	Condition		Min	Typ	Max	Unit
Supply Current, no load	$I_{DD}$	$C_L=0p$ $R_L=\infty$ $T=25^\circ C$	1MHz		6.0	6.3	mA
			27MHz		6.7	7.0	
			70MHz		7.7	8.1	
			150MHz		9.6	10.6	
Output Transition time		$C_L=15pF; T=25^\circ C$					
Rise Time	$t_R$	$20\%/80\%*V_{DD}$			1.0	2	ns
Fall Time	$t_F$				0.9	2	
Jitter, Max Cycle to Cycle	$J_{CC}$	$F = 100MHz^3$			50		ps

**VDD = 3.3v**

Parameter	Symbol	Condition		Min	Typ	Max	Unit
Supply Current, no load	$I_{DD}$	$C_L=0p$ $R_L=\infty$ $T=25^\circ C$	1MHz		6.0	6.3	mA
			27MHz		6.8	7.2	
			70MHz		8.2	8.7	
			150MHz		10.8	12.2	
Output Transition time		$C_L=15pF; T=25^\circ C$					
Rise Time	$t_R$	$20\%/80\%*V_{DD}$			1.0	2	ns
Fall Time	$t_F$				0.9	2	
Jitter, Max Cycle to Cycle	$J_{CC}$	$F = 100MHz^3$			50		ps

## Notes:

1. Absolute maximum ratings are those values beyond which the safety of the device cannot be guaranteed. The device should not be operated beyond these limits.
2.  $t_{SU}$  is time to stable output frequency after  $V_{DD}$  is applied.  $t_{SU}$  and  $t_{EN}$  (after EN is asserted) are identical values.
3. Measured over 50k clock cycles.

## Nominal Performance Characteristics

**Supply Current**

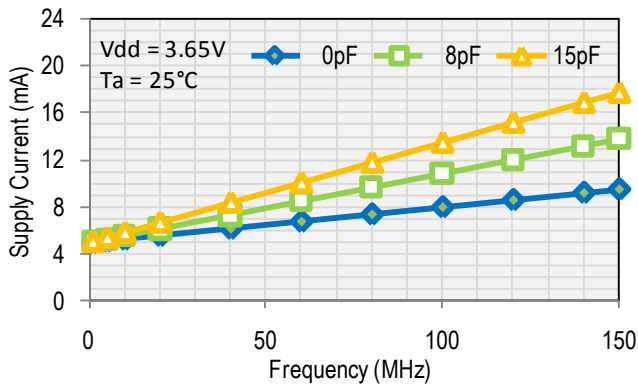

**Supply Current**

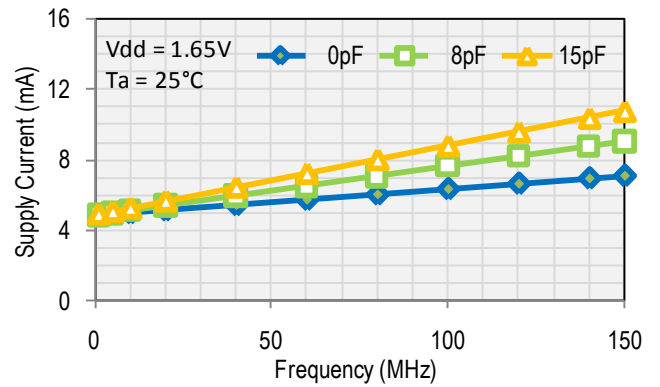

**Rise Time**

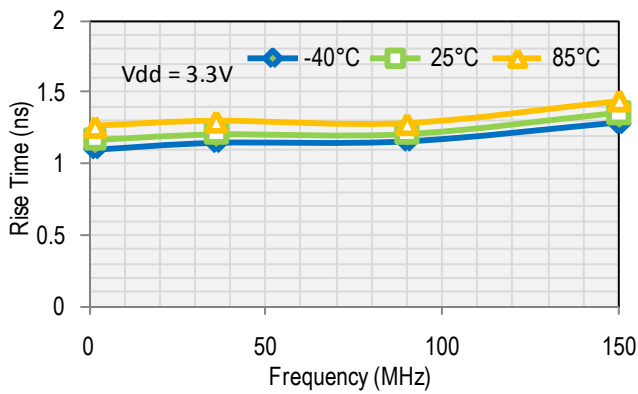

**Fall Time**

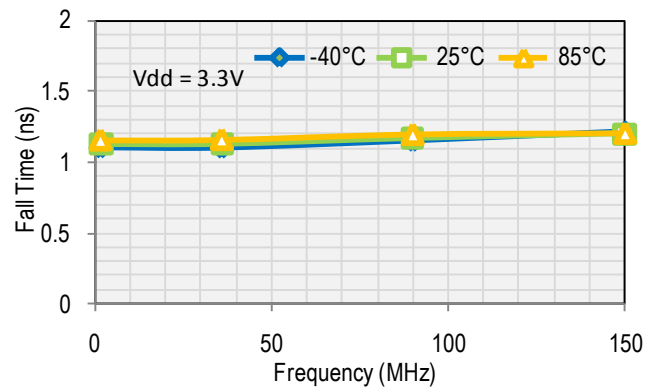

**Rise Time**

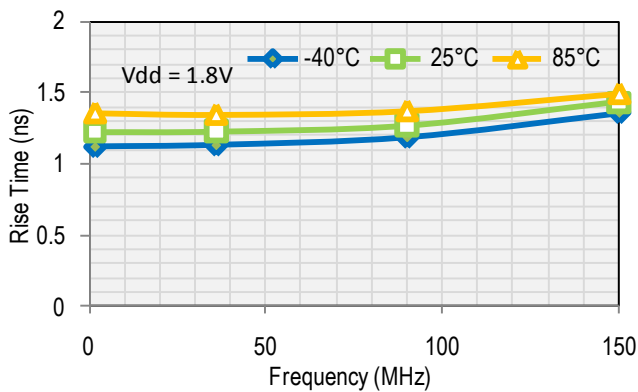

**Fall Time**

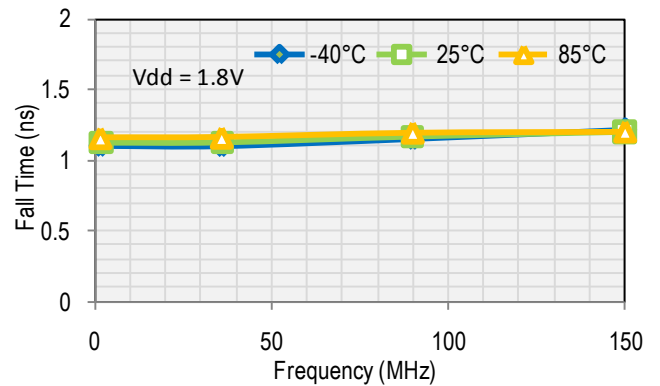

## Output Waveform

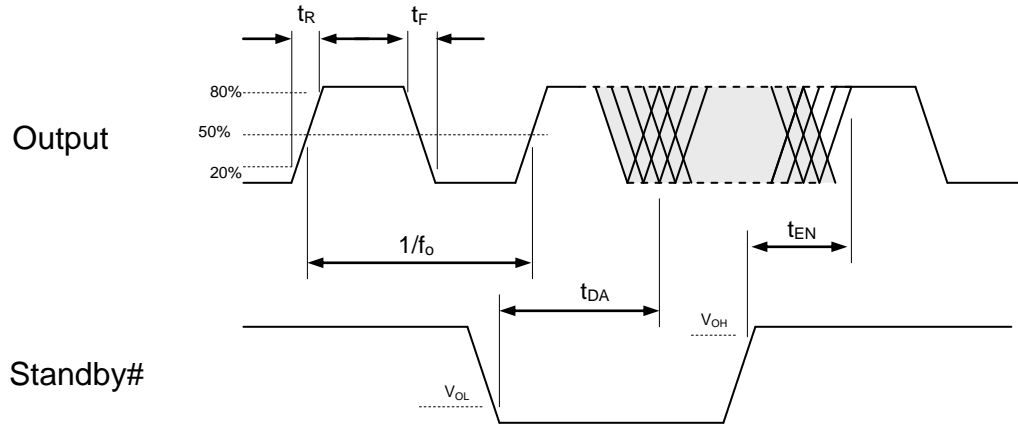

## Standby Function

Standby# (pin 1)	Output (pin 3)
Hi Level	Output ON
Open (no connect)	Output ON
Low Level	High Impedance

## Test Circuit

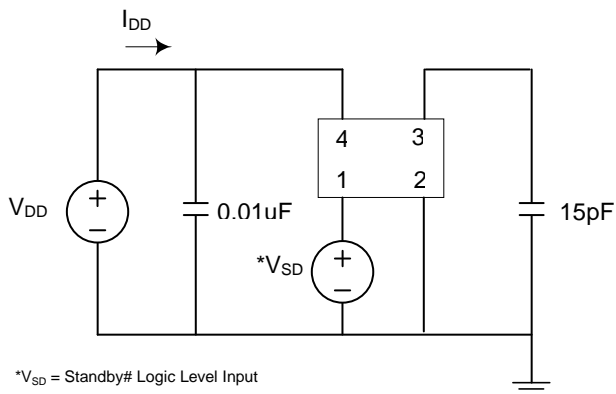

## Board Layout (recommended)

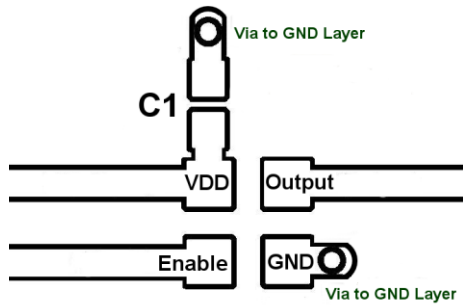

## Solder Reflow Profile

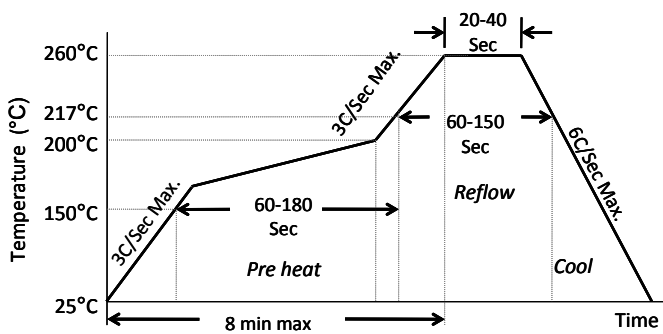

MSL 1 @ 260°C refer to JSTD-020C	
Ramp-Up Rate (200°C to Peak Temp)	3°C/Sec Max.
Preheat Time 150°C to 200°C	60-180 Sec
Time maintained above 217°C	60-150 Sec
Peak Temperature	255-260°C
Time within 5°C of actual Peak	20-40 Sec
Ramp-Down Rate	6°C/Sec Max.
Time 25°C to Peak Temperature	8 min Max.

## Package Dimensions

### 7.0 x 5.0 mm Plastic Package

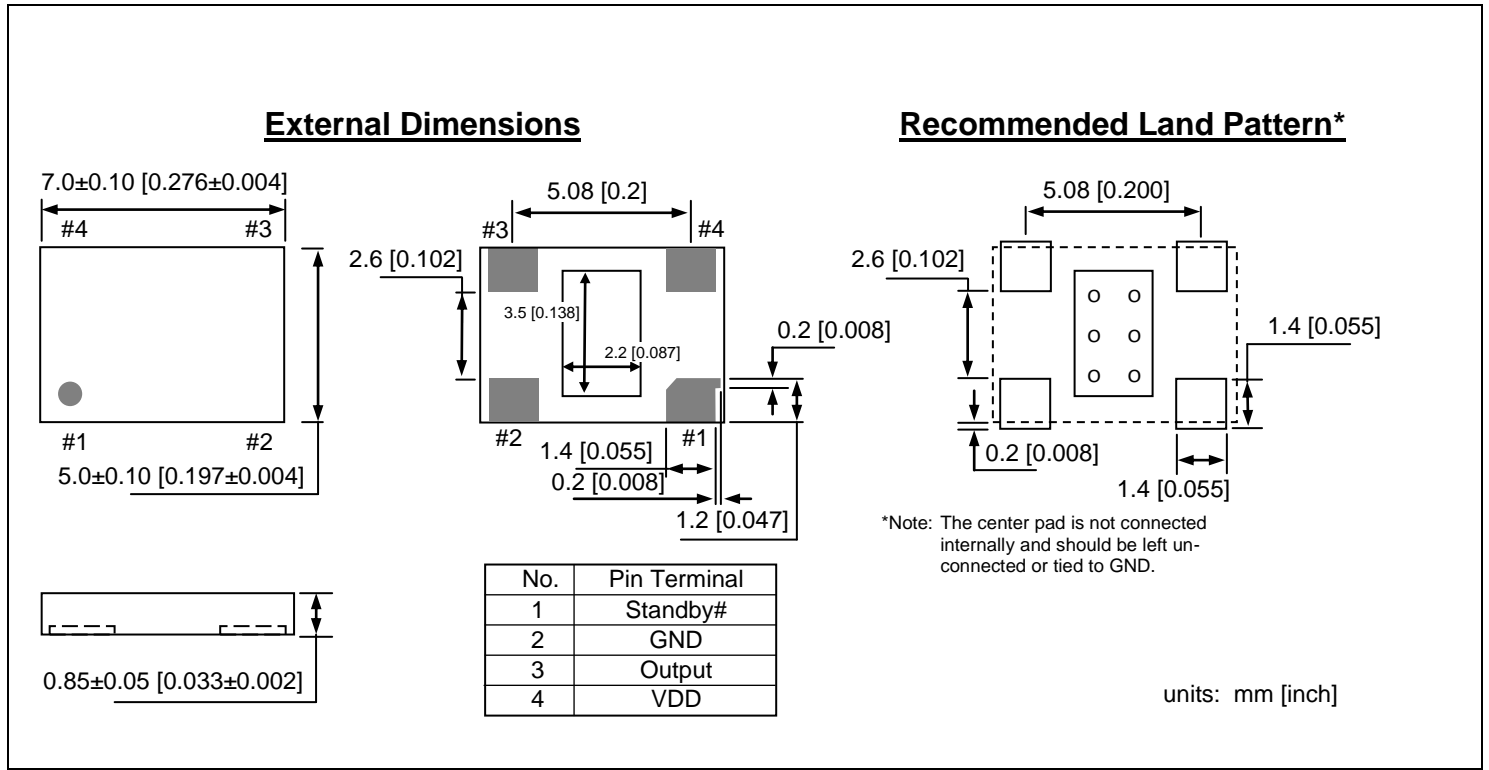

### 5.0 x 3.2 mm Plastic Package

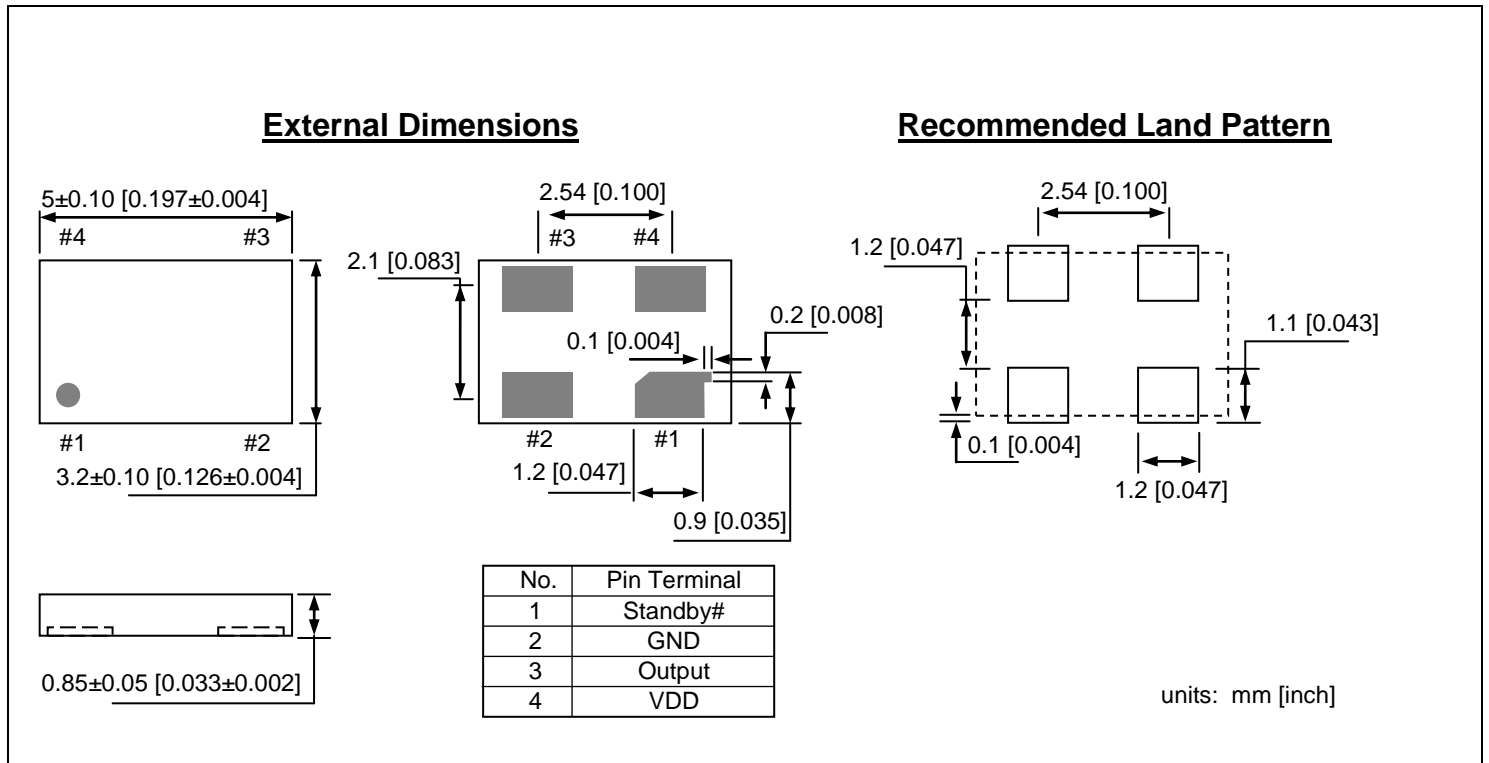

### 3.2 x 2.5 mm Plastic Package

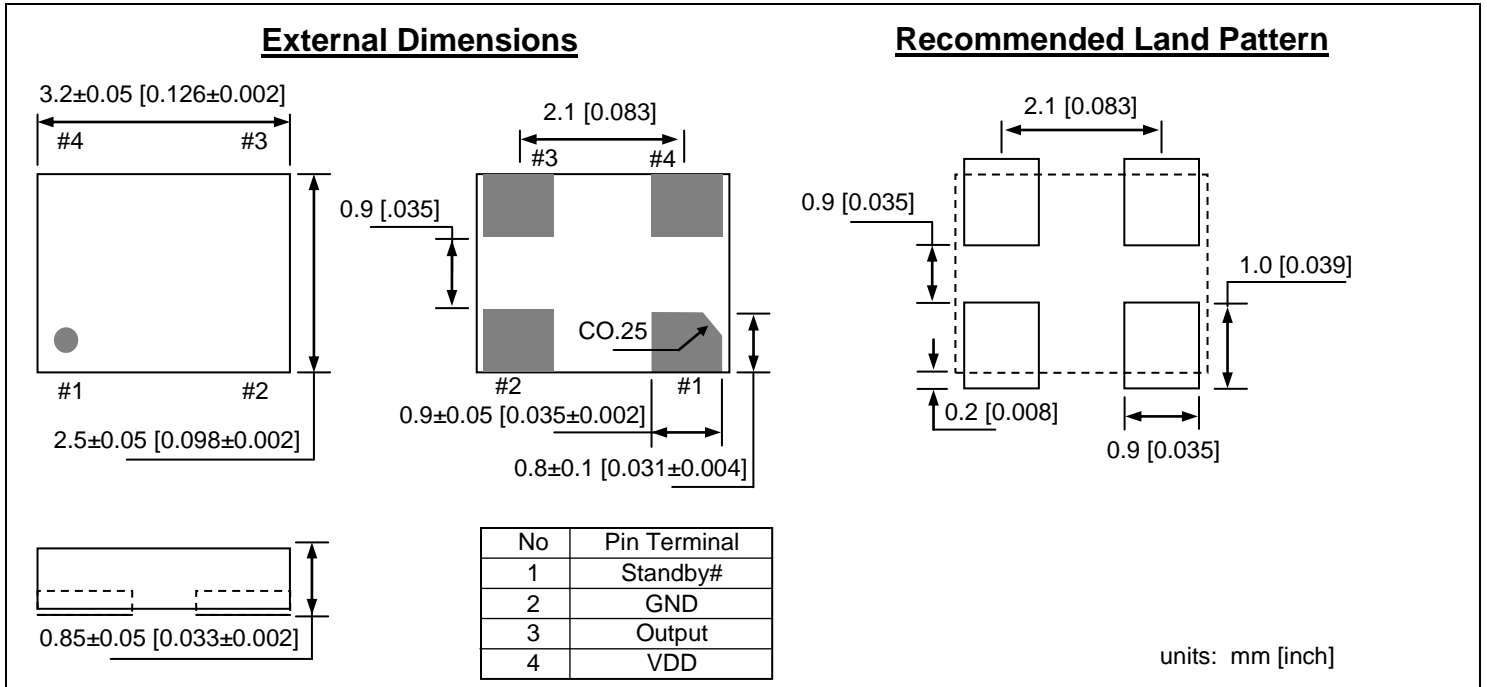

### 2.5 x 2.0 mm Plastic Package

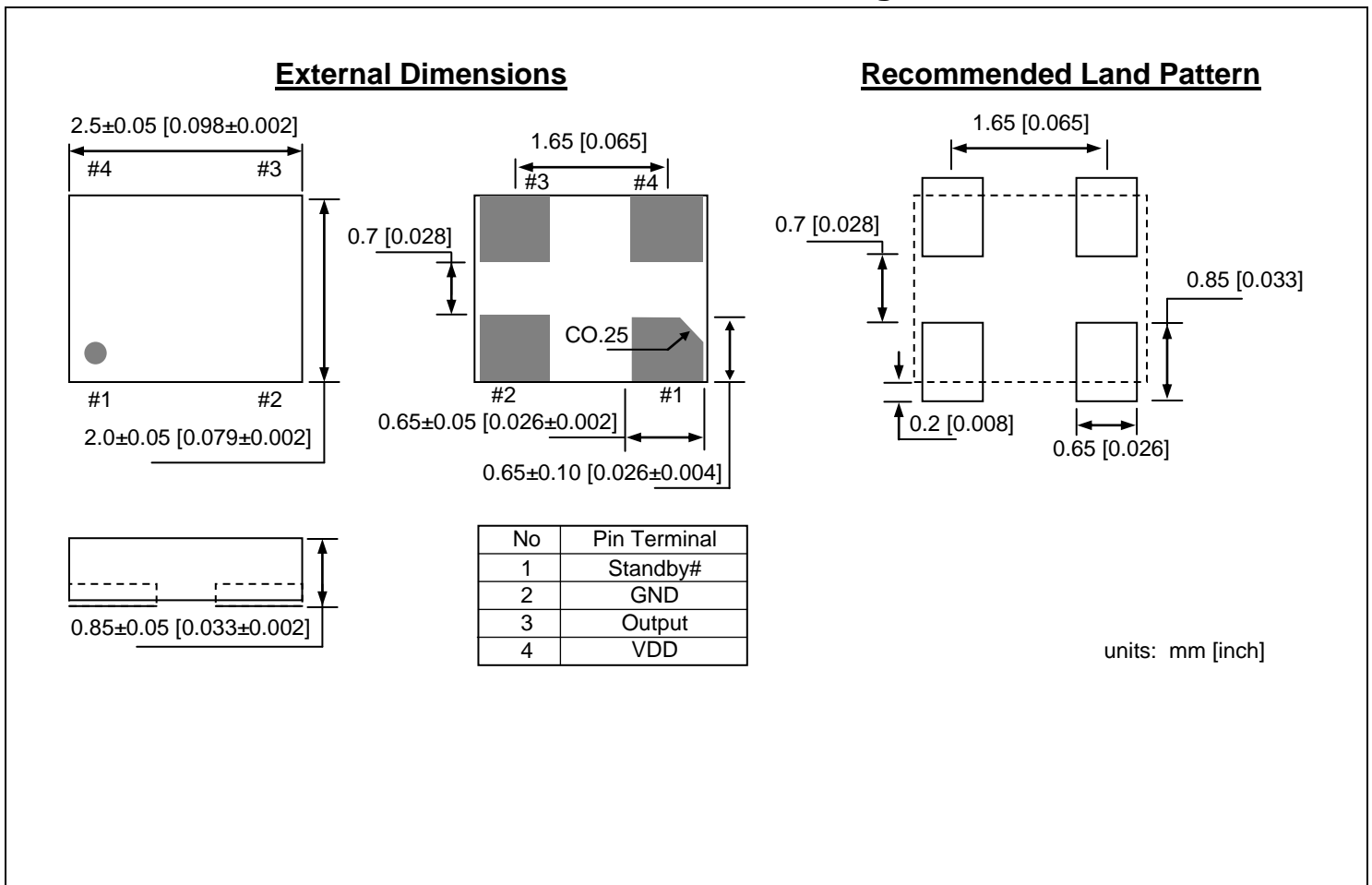



## Ordering Information

### DSC8001 PTS - T

PART NUMBERING GUIDE			
Package (Plastic QFN)	Temperature	Stability	Packing Option
<b>P=A:</b> 7.0x5.0mm <b>P=B:</b> 5.0x3.2mm <b>P=C:</b> 3.2x2.5mm <b>P=D:</b> 2.5x2.0mm	<b>T=C:</b> 0° ~ +70° C <b>T=E:</b> -20° ~ +70° C <b>T=I:</b> -40° ~ +85° C <b>T=L:</b> -40° ~ +105° C	<b>S=1:</b> ±50ppm <b>S=2:</b> ±25ppm <b>S=5:</b> ±10ppm	<b>Blank:</b> Tubes <b>T:</b> Tape & Reel

Example: DSC8001CE1-T

The example part number above is an unprogrammed oscillator in Plastic 3.2x2.5mm package, with ±50ppm stability over an operating temperature of -20 to +70°C, shipped in Tape and Reel.

### **Disclaimer:**

Discera makes no warranty of any kind, express or implied, with regard to this material, including, but not limited to, the implied warranties of merchantability and fitness for a particular purpose. Discera reserves the right to make changes without further notice to materials described herein. Discera does not assume any liability arising from the application or use of any product or circuit described herein. Discera does not authorize its products for use a critical components in life-support systems where a malfunction or failure may reasonably be expected to result in significant injury to the user. The inclusion of Discera's product in a life-support systems application implies that the manufacturer assumes all risk of such use and in doing so indemnifies Discera against all charges.

## X-ON Electronics

Largest Supplier of Electrical and Electronic Components

*Click to view similar products for [Programmable Oscillators](#) category:*

*Click to view products by [Microchip](#) manufacturer:*

Other Similar products are found below :

[8N4Q001LG-0102CDI](#) [8N4Q001LG-0139CDI](#) [DSC8101AL2](#) [8N0Q001BH-2202CDI](#) [DSC8101DI5](#) [DSC8121AI5](#) [EP16E7E2H26.000MTR](#)  
[SIT8102AI-13-18E-25.00000T](#) [8N4Q001LG-1033CDI](#) [DSC8121CL5T](#) [DS1090U-2/V+T](#) [DS1090U-32+T](#) [DSC8121AM2](#) [DSC8001AL2](#)  
[DSC8101BL2](#) [DSC8121CI1](#) [DSC8124CI5](#) [DSC8003CI2T](#) [DSC8102DI2](#) [DSC8124CI2](#) [DSC8123CI5](#) [DSC8124BI2](#) [DSC8122BI5](#)  
[DSC8101DI2](#) [DSC8121CL5](#) [SiT8008AI-71-XXX-000.FP000G](#) [SG-8002JA 20.000M-PTMB-ROHS](#) [ECS-P143-10-AN](#) [570FCC001204DG](#)  
[570FCC000169DG](#) [544BAEB002025CBG](#) [544BAHB002172BBGR](#) [544BAHB002157BBGR](#) [DS1077LU-40+T](#) [SiT3808AI-D2-XXXX-](#)  
[000.FP000X](#) [DS1090U-1+T](#) [DS1086Z+T&R](#) [DS1087LU-447+T](#) [544BCAA000112BBG](#) [DS1086LU+T](#) [564BACA001478ABG](#) [SG-8002CA](#)  
[2.4576M-PCBB](#) [564BACA000121ABG](#) [564BACA001478BBG](#) [564BABA002053ABG](#) [564BAAA000121ABG](#) [564BAAC000115BBG](#)  
[564BAAD000115BBG](#) [ECS-P8F3X-1.000-AN](#) [570CBC000306DG](#)