

*Parameters Subject to Change Without Notice*

## DESCRIPTION

The JW<sup>®</sup>5017F is a current mode monolithic buck switching regulator. Operating with an input range of 4.5V~26V, the JW5017F delivers 1.2A of continuous output current with two integrated N-Channel MOSFETs. The JW5017F operates in fixed 1.2MHz for all load range to prevent low frequency interference.

The JW5017F guarantees robustness with over current protection, thermal protection, start-up current run-away protection, and input under voltage lockout.

The JW5017F is available in 6-pin SOT23-6 package, which provides a compact solution with minimal external components.

Company's Logo is Protected, "JW" and "JOULWATT" are Registered Trademarks of JoulWatt technology Inc.

## FEATURES

- 4.5 V to 26 V operating input range
- 1.2A output current
- Up to 94% efficiency
- Internal Soft-Start
- Fixed 1.2MHz Switching frequency
- Available in SOT23-6 package
- Input under voltage lockout
- Start-up current run-away protection
- Over current protection and Hiccup
- Thermal protection

## APPLICATIONS

- Distributed Power Systems
- Automotive Systems
- High Voltage Power Conversion
- Industrial Power Systems
- Battery Powered Systems

## TYPICAL APPLICATION

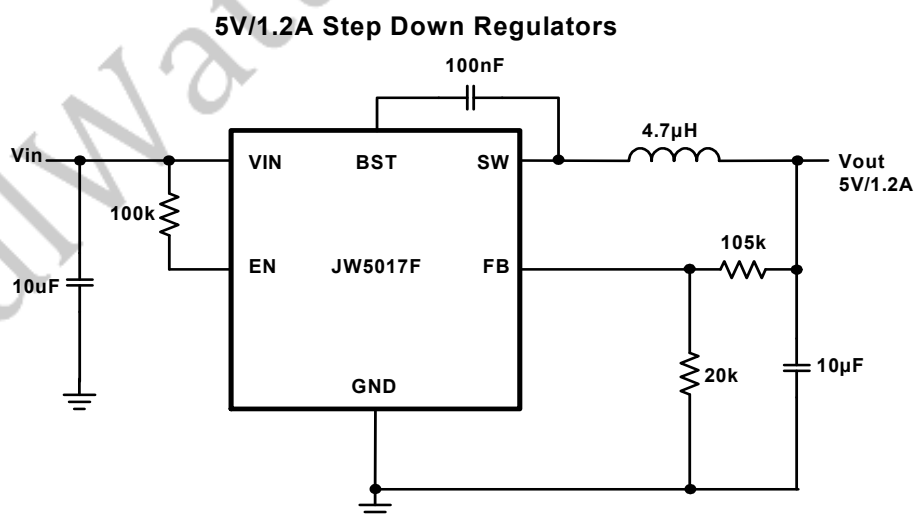

**ORDER INFORMATION**

DEVICE <sup>1)</sup>	PACKAGE	TOP MARKING <sup>2)</sup>
JW5017FSOTB#TRPBF	SOT23-6	JWE6X YWLLL

**Notes :**

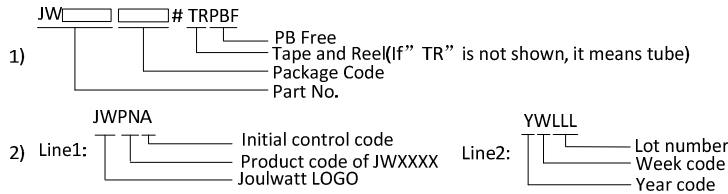

**PIN CONFIGURATION**

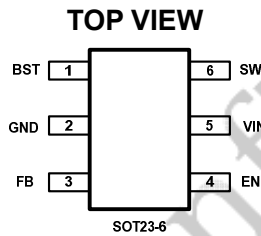

**ABSOLUTE MAXIMUM RATING<sup>1)</sup>**

VIN, EN Pin	-0.3V to 27V
SW	-0.3V(-4V for 5ns) to 27V(28V for 10ns)
BST Pin	SW-0.3V to SW+5V
All other Pins	-0.3V to 6V
Junction Temperature <sup>2) 3)</sup>	150°C
Lead Temperature	260°C
Storage Temperature	-65°C to +150°C
ESD Susceptibility (Human Body Model)	2kV

**RECOMMENDED OPERATING CONDITIONS**

Input Voltage VIN	4.5V to 26V
Output Voltage Vout	0.8V to 21V
Operating Junction Temperature	-40°C to 125°C

**THERMAL PERFORMANCE<sup>4)</sup>**

	$\theta_{JA}$	$\theta_{Jc}$
SOT23-6	220...130°C/W	

**Note :**

- 1) Exceeding these ratings may damage the device.
- 2) The JW5017F guarantees robust performance from -40°C to 150°C junction temperature. The junction temperature range specification is assured by design, characterization and correlation with statistical process controls.

- 3) The JW5017F includes thermal protection that is intended to protect the device in overload conditions. Thermal protection is active when junction temperature exceeds the maximum operating junction temperature. Continuous operation over the specified absolute maximum operating junction temperature may damage the device.
- 4) Measured on JESD51-7, 4-layer PCB.

JoulWatt Confidential

**ELECTRICAL CHARACTERISTICS**

$V_{IN} = 12V, T_A = 25^{\circ}C$ , unless otherwise stated.

Item	Symbol	Condition	Min.	Typ.	Max.	Units
$V_{IN}$ Under voltage Lockout Threshold	$V_{IN\_MIN}$	$V_{IN}$ falling	4	4.2	4.4	V
$V_{IN}$ Under voltage Lockout Hysteresis <sup>5)</sup>	$V_{IN\_MIN\_HYST}$	$V_{IN}$ rising		300		mV
Shutdown Supply Current	$I_{SD}$	$V_{EN}=0V$		0.1	1	$\mu A$
Supply Current	$I_Q$	$V_{EN}=5V, V_{FB}=1.2V$		1.7	2	mA
Feedback Voltage	$V_{FB}$	$4.5V < V_{IN} < 26V$	776	800	824	mV
Top Switch Resistance <sup>5)</sup>	$R_{DS(ON)T}$			300		m $\Omega$
Bottom Switch Resistance <sup>5)</sup>	$R_{DS(ON)B}$			150		m $\Omega$
Top Switch Leakage Current	$I_{LEAK\_TOP}$	$V_{IN}=26V, V_{EN}=0V, V_{SW}=0V$			1	$\mu A$
Bottom Switch Leakage Current	$I_{LEAK\_BOT}$	$V_{IN}=V_{SW}=26V, V_{EN}=0V$			1	$\mu A$
Top Switch Current Limit <sup>5)</sup>	$I_{LIM\_TOP}$	Minimum Duty Cycle		2		A
Switch Frequency	$f_{SW}$		1.0	1.2	1.4	MHz
Minimum On Time <sup>5)</sup>	$T_{ON\_MIN}$			80		ns
Minimum Off Time <sup>5)</sup>	$T_{OFF\_MIN}$	$V_{FB}=0.6V$		120		ns
EN Shutdown Threshold	$V_{EN\_TH}$	$V_{EN}$ falling, $FB=0V$	1.2	1.3	1.4	V
EN Shutdown Hysteresis <sup>5)</sup>	$V_{EN\_HYST}$	$V_{EN}$ rising, $FB=0V$		100		mV
Thermal Shutdown <sup>5)</sup>	$T_{TSD}$			150		$^{\circ}C$
Thermal Shutdown hysteresis <sup>5)</sup>	$T_{TSD\_HYST}$			15		$^{\circ}C$

**Note :**

5) Guaranteed by design.

**PIN DESCRIPTION**

Pin	Name	Description
1	BST	Bootstrap pin for top switch. A 0.1uF or larger capacitor should be connected between this pin and the SW pin to supply current to the top switch and top switch driver.
2	GND	Ground.
3	FB	Output feedback pin. FB senses the output voltage and is regulated by the control loop to 800mV. Connect a resistive divider at FB.
4	EN	Drive EN pin high to turn on the regulator and low to turn off the regulator.
7	VIN	Input voltage pin. VIN supplies power to the IC. Connect a 4.5V to 26V supply to VIN and bypass VIN to GND with a suitably large capacitor to eliminate noise on the input to the IC.
8	SW	SW is the switching node that supplies power to the output. Connect the output LC filter from SW to the output load.

**BLOCK DIAGRAM**

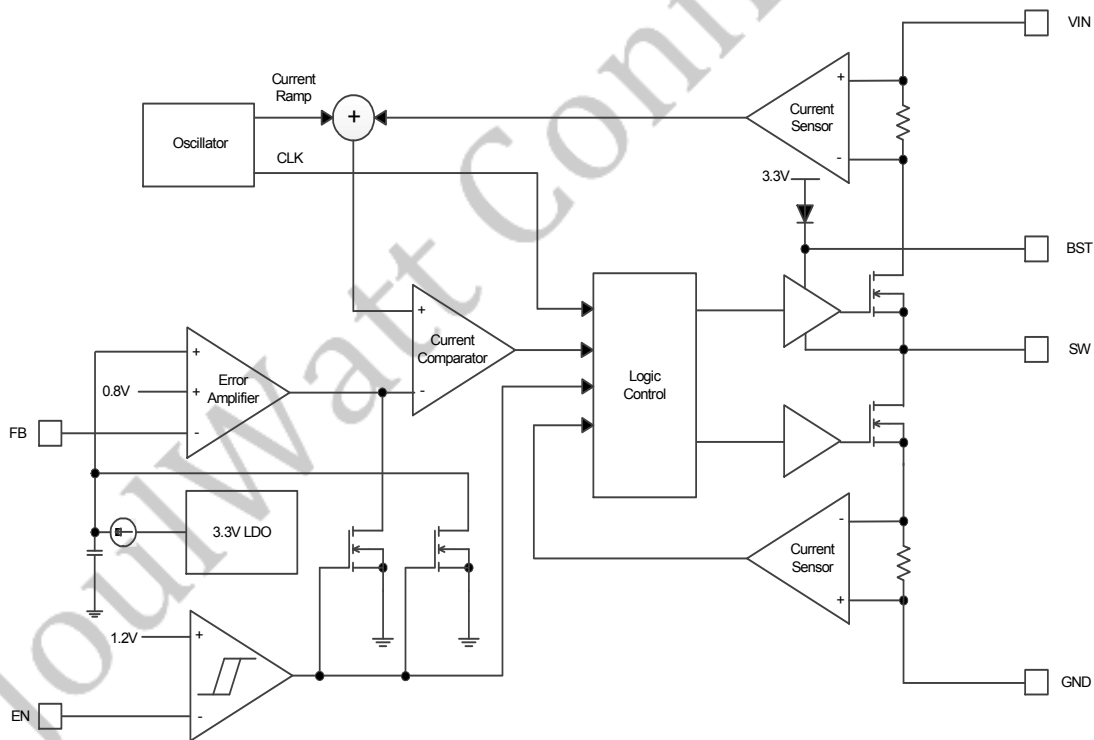

# TYPICAL PERFORMANCE CHARACTERISTICS

Vin = 12V, Vout = 3.3V, L = 4.7μH, Cout = 10μF, TA = +25°C, unless otherwise noted

### Steady State Test

VIN=12V, Vout=3.3V  
Iout=1.2A

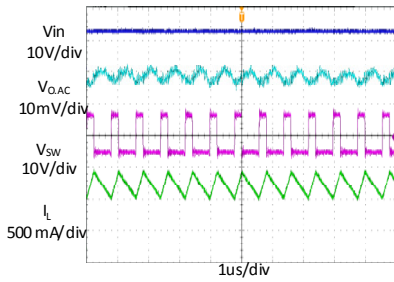

### Startup through Enable

VIN=12V, Vout=3.3V  
Iout=1.2A(Resistive load)

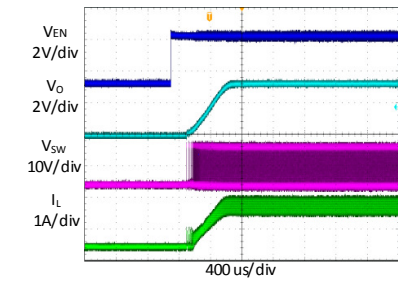

### Shutdown through Enable

VIN=12V, Vout=3.3V  
Iout=1.2A(Resistive load)

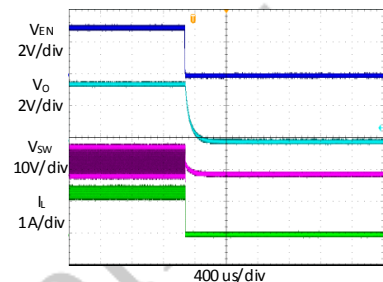

### Heavy Load Operation

1.2A LOAD

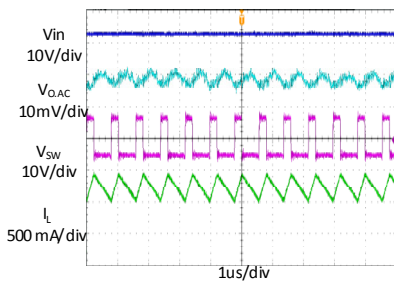

### Medium Load Operation

0.6A LOAD

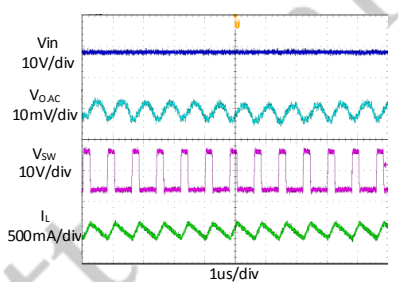

### Light Load Operation

0 A LOAD

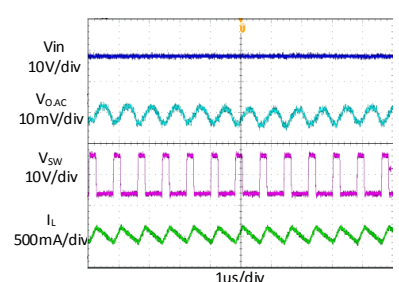

### Short Circuit Protection

VIN=12V, Vout=3.3V  
Iout=1.2A- Short

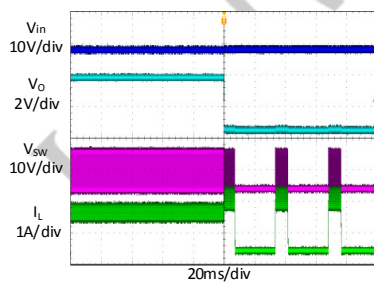

### Short Circuit Protection

VIN=12V, Vout=3.3V  
Iout= Short -1.2A

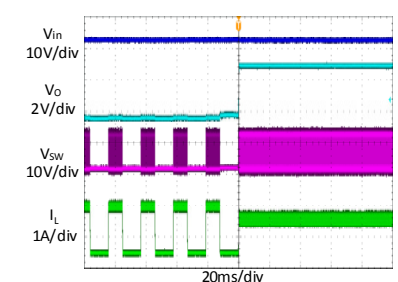

### Load Transient

0.6A LOAD → 1.2A LOAD → 0.6A LOAD

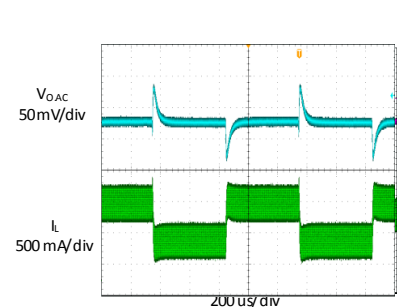

**TYPICAL PERFORMANCE CHARACTERISTICS (continued)**

Vin = 12V, Vout = 3.3V, L = 4.7μH, Cout = 10μF, TA = +25°C, unless otherwise noted

**Load regulation @ Vout=3.3V**

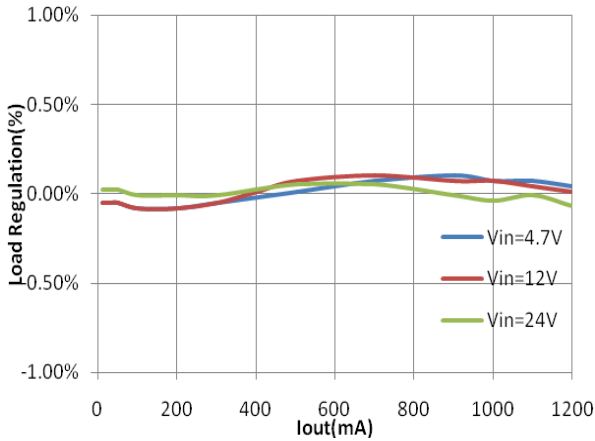

**Shutdown Current Vs. Input Voltage**

VIN=4.5V ~ 26V, VEN=0V

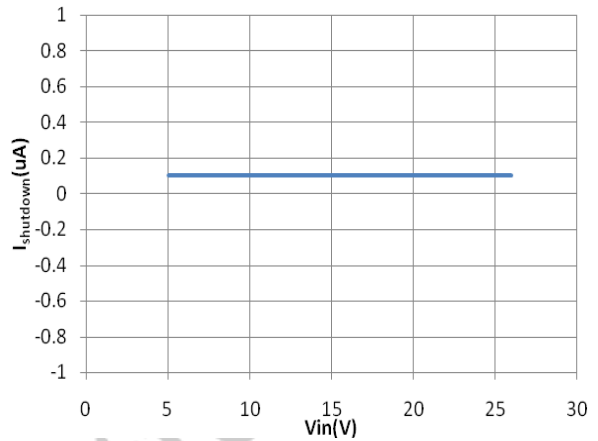

**Efficiency @ Vout=3.3V**

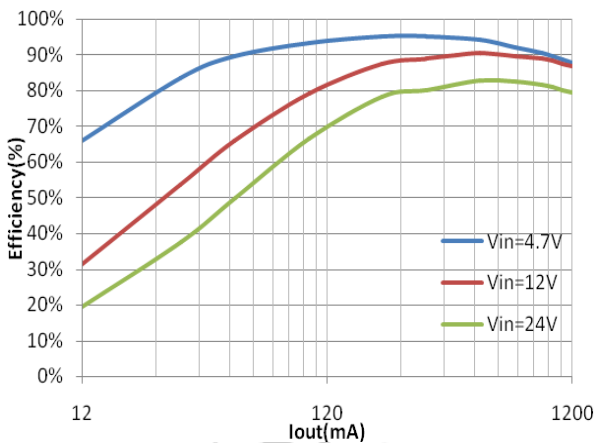

**Efficiency @ Vout=5V**

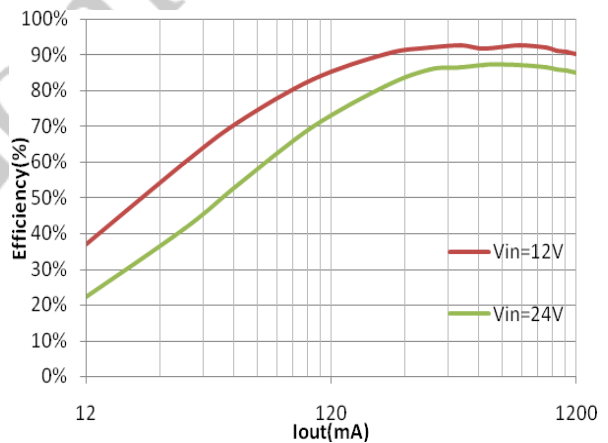

**Current Limit**

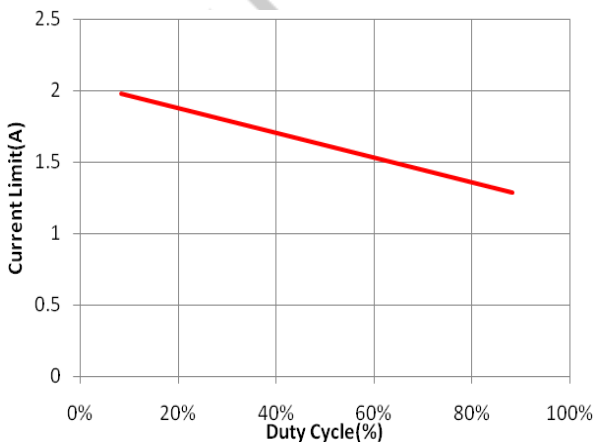

## FUNCTIONAL DESCRIPTION

The JW5017F is a synchronous, current-mode, step-down regulator. It regulates input voltage from 4.5V to 26V down to an output voltage as low as 0.8V, and is capable of supplying up to 1.2A of load current.

### Current-Mode Control

The JW5017F utilizes current-mode control to regulate the output voltage. The output voltage is measured at the FB pin through a resistive voltage divider and the error is amplified by the internal trans conductance error amplifier. Output of the internal error amplifier is compared with the switch current measured internally to control the output current limit.

### Shut-Down Mode

The JW5017F operates in shut-down mode when voltage at EN pin is driven below 0.3V. In shut-down mode, the entire regulator is off and the supply current consumed by the JW5017F drops below 0.1uA.

### Power Switch

N-Channel MOSFET switches are integrated on the JW5017F to down convert the input voltage to the regulated output voltage. Since the top MOSFET needs a gate voltage greater than the input voltage, a boost capacitor connected between BST and SW pins is required to drive the gate of the top switch. The boost capacitor is charged by the internal 3.3V rail when SW is low.

### Vin Under-Voltage Protection

A resistive divider can be connected between Vin and ground, with the central tap connected to EN, so that when Vin drops to the pre-set value, EN drops below 1.2V to trigger input under voltage lockout protection.

### Output Current Run-Away Protection

At start-up, due to the high voltage at input and low voltage at output, current inertia of the output inductance can be easily built up, resulting in a large start-up output current. A valley current limit is designed in the JW5017F so that only when output current drops below the valley current limit can the bottom power switch be turned off. By such control mechanism, the output current at start-up is well controlled.

### Over Current Protection and Hiccup

JW5017F has a cycle-by-cycle current limit. When the inductor current triggers current limit, JW5017F enters hiccup mode and periodically restart the chip. JW5017F will exit hiccup mode while not triggering current limit.

### Thermal Protection

When the temperature of the JW5017F rises above 140°C, it is forced into thermal shut-down. Only when core temperature drops below 125°C can the regulator becomes active again.



## APPLICATION INFORMATION

### Output Voltage Set

The output voltage is determined by the resistor divider connected at the FB pin, and the voltage ratio is:

$$V_{FB} = V_{OUT} \frac{R_2}{R_2 + R_3}$$

where  $V_{FB}$  is the feedback voltage and  $V_{OUT}$  is the output voltage.

Choose  $R_2$  around 20kΩ, and then  $R_3$  can be calculated by:

$$R_3 = R_2 \cdot \left( \frac{V_{OUT}}{0.8V} - 1 \right)$$

The following table lists the recommended values.

V <sub>OUT</sub> (V)	R <sub>2</sub> (Kω)	R <sub>3</sub> (Kω)
2.5	22.1	47
3.3	16	49.9
5	20	105

### Input Capacitor

The input capacitor is used to supply the AC input current to the step-down converter and maintaining the DC input voltage. The ripple current through the input capacitor can be calculated by:

$$I_{C1} = I_{LOAD} \cdot \sqrt{\frac{V_{OUT}}{V_{IN}} \cdot \left( 1 - \frac{V_{OUT}}{V_{IN}} \right)}$$

where  $I_{LOAD}$  is the load current,  $V_{OUT}$  is the output voltage,  $V_{IN}$  is the input voltage.

Thus the input capacitor can be calculated by the following equation when the input ripple voltage is determined.

$$C_1 = \frac{I_{LOAD}}{f_s \cdot \Delta V_{IN}} \cdot \frac{V_{OUT}}{V_{IN}} \cdot \left( 1 - \frac{V_{OUT}}{V_{IN}} \right)$$

where  $C_1$  is the input capacitance value,  $f_s$  is the switching frequency,  $\Delta V_{IN}$  is the input ripple voltage.

The input capacitor can be electrolytic, tantalum or ceramic. To minimizing the potential noise, a small X5R or X7R ceramic capacitor, i.e. 0.1Uf, should be placed as close to the IC as possible when using electrolytic capacitors.

A 10Uf ceramic capacitor is recommended in typical application.

### Output Capacitor

The output capacitor is required to maintain the DC output voltage, and the capacitance value determines the output ripple voltage. The output voltage ripple can be calculated by:

$$\Delta V_{OUT} = \frac{V_{OUT}}{f_s \cdot L} \cdot \left( 1 - \frac{V_{OUT}}{V_{IN}} \right) \cdot \left( R_{ESR} + \frac{1}{8 \cdot f_s \cdot C_2} \right)$$

where  $C_2$  is the output capacitance value and  $R_{ESR}$  is the equivalent series resistance value of the output capacitor.

The output capacitor can be low ESR electrolytic, tantalum or ceramic, which lower ESR capacitors get lower output ripple voltage.

The output capacitors also affect the system stability and transient response, and a 10Uf ceramic capacitor is recommended in typical application.

### Inductor

The inductor is used to supply constant current to the output load, and the value determines the

ripple current which affect the efficiency and the output voltage ripple. The ripple current is typically allowed to be 40% of the maximum switch current limit, thus the inductance value can be calculated by:

$$L = \frac{V_{OUT}}{f_s \cdot \Delta I_L} \cdot \left(1 - \frac{V_{OUT}}{V_{IN}}\right)$$

where  $V_{IN}$  is the input voltage,  $V_{OUT}$  is the output voltage,  $f_s$  is the switching frequency, and  $\Delta I_L$  is the peak-to-peak inductor ripple current.

### External Bootstrap Capacitor

A bootstrap capacitor is required to supply voltage to the top switch driver. A 0.1Uf low ESR ceramic capacitor is recommended to connected to the BST pin and SW pin.

### PCB Layout Note

For minimum noise problem and best operating performance, the PCB is preferred to following the guidelines as reference.

1. Place the input decoupling capacitor as close to JW5017F (VIN pin and PGND) as possible to eliminate noise at the input pin. The loop area formed by input capacitor and GND must be minimized.
2. Put the feedback trace as far away from the inductor and noisy power traces as possible.
3. The ground plane on the PCB should be as large as possible for better heat dissipation

REFERENCE DESIGN

Reference 1:

$V_{IN}$  : 4.7V ~ 26V

$V_{OUT}$ : 3.3V

$I_{OUT}$  : 0~1.2A

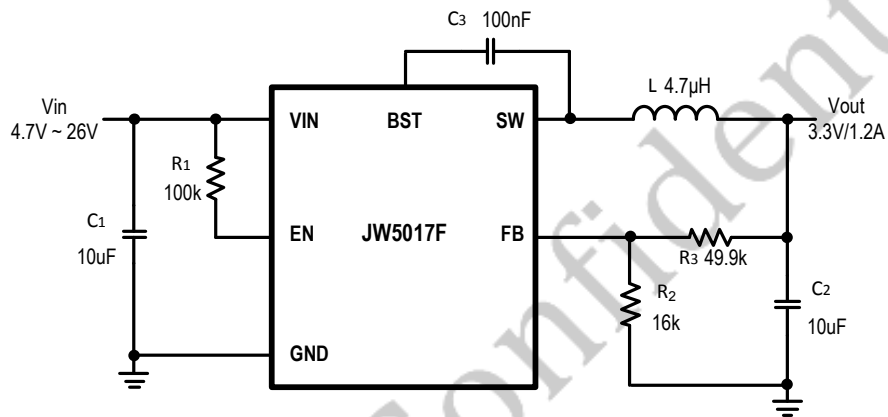

Reference 2:

$V_{IN}$  : 7V ~ 26V

$V_{OUT}$ : 5V

$I_{OUT}$  : 0~1.2A

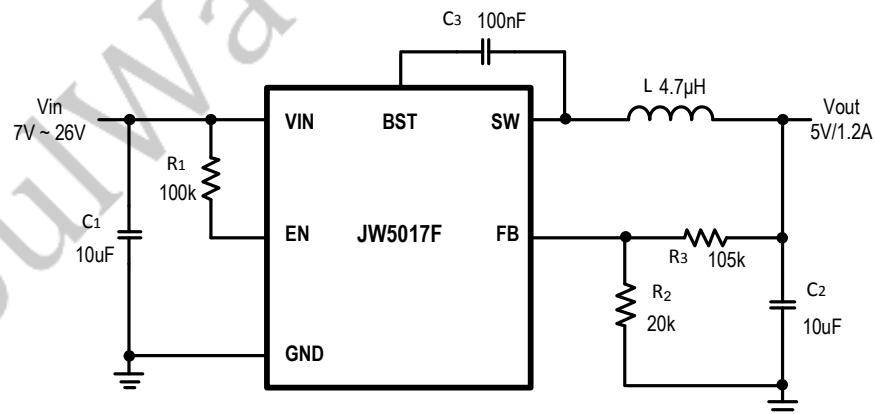

PACKAGE OUTLINE

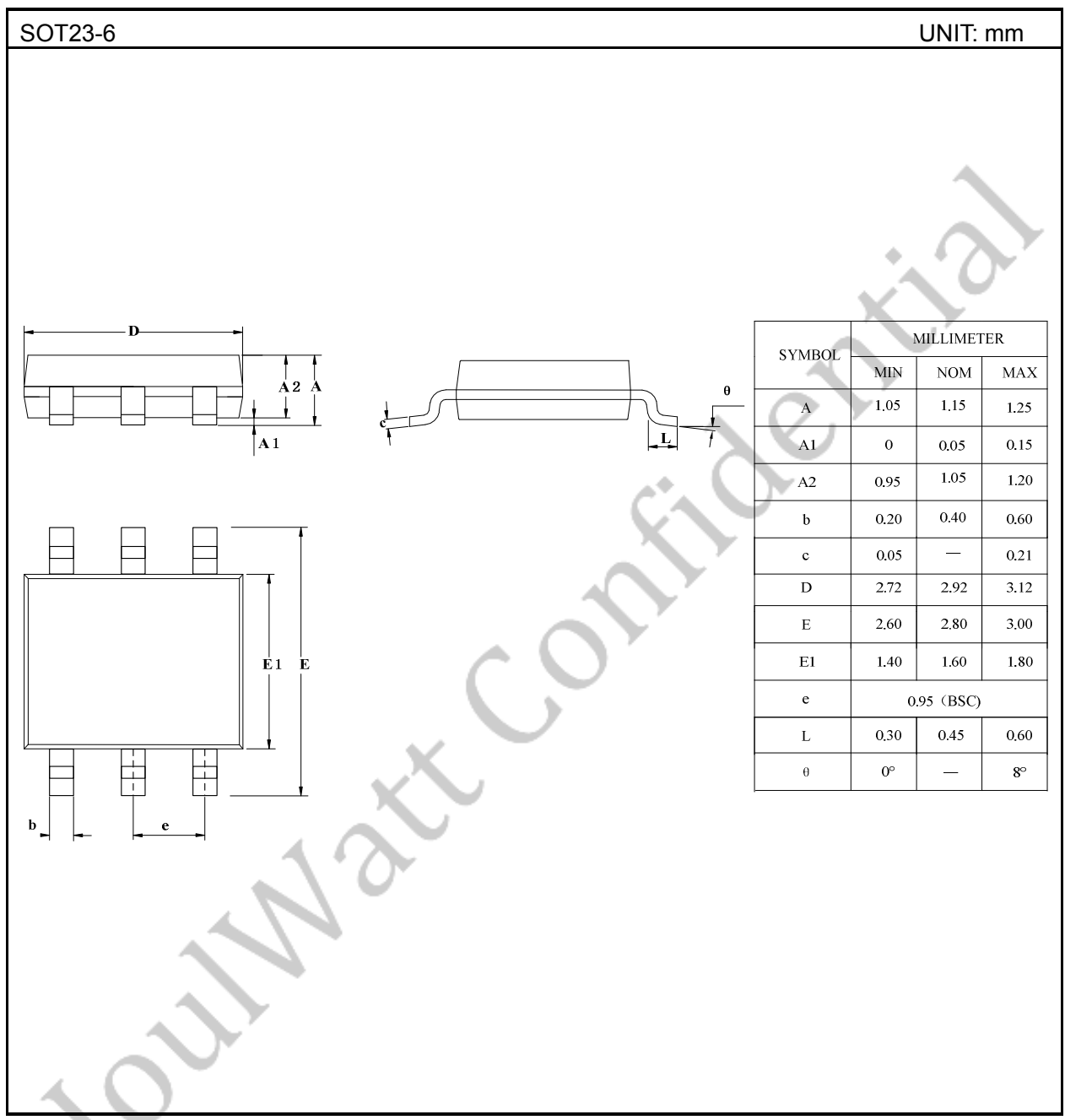

**IMPORTANT NOTICE**

- Joulwatt Technology Inc. reserves the right to make modifications, enhancements, improvements, corrections or other changes without further notice to this document and any product described herein.
- Any unauthorized redistribution or copy of this document for any purpose is strictly forbidden.
- Joulwatt Technology Inc. does not warrant or accept any liability whatsoever in respect of any products purchased through unauthorized sales channel.

JoulWatt Confidential

*Copyright © 2016 JW5017F Incorporated.*

*All rights are reserved by Joulwatt Technology Inc.*

## X-ON Electronics

Largest Supplier of Electrical and Electronic Components

*Click to view similar products for [Isolated DC/DC Converters](#) category:*

*Click to view products by [JoulWatt](#) manufacturer:*

Other Similar products are found below :

[ESM6D044440C05AAQ](#) [FMD15.24G](#) [PSL486-7LR](#) [PSR152.5-7IR](#) [Q48T30020-NBB0](#) [AVO240-48S12B-6L](#) [AVO250-48S28B-6L](#) [NAN-0505](#) [HW-L16D](#) [JAHW100Y1](#) [217-1617-001](#) [22827](#) [SPB05C-12](#) [SQ24S15033-PS0S](#) [18952](#) [19-130041](#) [CE-1003](#) [CE-1004](#) [GQ2541-7R](#) [PSE1000DCDC-12V](#) [RDS180245](#) [MAU228](#) [419-2065-201](#) [449-2075-101](#) [TME 0303S](#) [TME 0505S](#) [TME 1205S](#) [TME 1212S](#) [TME 2405S](#) [TME 2412S](#) [J80-0041NL](#) [V300C24C150BG](#) [419-2062-200](#) [419-2063-401](#) [419-2067-101](#) [419-2067-501](#) [419-2068-001](#) [DCG40-5G](#) [DFC15U48D15](#) [449-2067-000](#) [XGS-0512](#) [XGS-1205](#) [XGS-1212](#) [XGS-2412](#) [XGS-2415](#) [XKS-1215](#) [033456](#) [NCT1000N040R050B](#) [SPB05B-15](#) [SPB05C-15](#)