





Low voltage ceramic capacitors up to 500V

NO.	STE-WI-001-01	Date	2019-01-21
Ver.	V 1.0	Page	Page 2 of 15

### Change record table

NO.	Date	Edition	The reasons of change	Description
1	2019.01.21	Original	/	The first time
2				
3				
4				
5				

<p>头高新区松田实业有限公司 SHANTOU HIGH-NEW ZONE SONGTIAN ENTERPRISE CO., LTD 汕头保税区松田电子科技有限公司 Shantou Bonded Area Songtian Electronics Technology Ltd. Add:No.9,kejixi Rd,GaoXinQu,Shantou City,Guangdong,CHINA. Shantou Free Trade Zone Songtian Technology Park East area , Songtian Technology Park West area. P.O.BOX:515041 Tel: 86-754-88266532 Fax: 86-754-88266546 E-mail:888@songtian.cn</p>	Modify	Checked	Approval
	Jiali Zheng	Xiaokui Chen	Minghui Zhao





# Low voltage ceramic capacitors up to 500V

NO.	STE-WI-001-01	Date	2019-01-21
Ver.	V 1.0	Page	Page 3 of 15

Attachment:

## Product specification

No.	Part No.	Part No. Of STE	Specs Of STE	Note*
1		F05S1B101KN0B0SHN0	50V-SL-101K	CC1
2		F05B1B221KN0B0SHN0	50V-Y5P-221K	CT1
3		F05B1B331KN0B0SHN0	50V-Y5P-331K	CT1
4		F05B1B471KN0B0SHN0	50V-Y5P-471K	CT1
5		F05B1B681KN0B0SHN0	50V-Y5P-681K	CT1
6		F05B1B102KN0B0SHN0	50V-Y5P-102K	CT1
7		F05B1B222KN0B0SHN0	50V-Y5P-222K	CT1
8		F05F1B472MN0B0SHN0	50V-Y5V-472M	CT1
9		F05B1B472KN0B0SHN0	50V-Y5P-472K	CT1
10		F05F1B103MN0B0SHN0	50V-Y5V-103M	CT1
11		F05B1B103KN0B0SHN0	50V-Y5P-103K	CT1
12		F05F1B473ZN0B0SHN0	50V-Y5V-473Z	CS1
13		F05F1B473MN0B0SHN0	50V-Y5V-473M	CS1
14		FC6F1B104ZN0B0SHN0	50V-Y5V-104Z	CS1
15		FC6F1B104MN0B0SHN0	50V-Y5V-104M	CS1
16		F06F1B104ZN0B0SHN0	50V-Y5V-104Z	CS1
17		F06F1B104MN0B0SHN0	50V-Y5V-104M	CS1
18		F08F1B224ZN0B0SHN0	50V-Y5V-224Z	CS1
19		F08F1B224MN0B0SHN0	50V-Y5V-224M	CS1
20		F05S1B101KQ0T0SHN0	50V-SL-101K	CC1
21		F05B1B221KQ0T0SHN0	50V-Y5P-221K	CT1
22		F05B1B331KQ0T0SHN0	50V-Y5P-331K	CT1
23		F05B1B471KQ0T0SHN0	50V-Y5P-471K	CT1
24		F05B1B681KQ0T0SHN0	50V-Y5P-681K	CT1
25		F05B1B102KQ0T0SHN0	50V-Y5P-102K	CT1
26		F05B1B222KQ0T0SHN0	50V-Y5P-222K	CT1
27		F05F1B472MQ0T0SHN0	50V-Y5V-472M	
28		F05B1B472KQ0T0SHN0	50V-Y5P-472K	





# Low voltage ceramic capacitors up to 500V

NO.	STE-WI-001-01	Date	2019-01-21
Ver.	V 1.0	Page	Page 4 of 15

29		FC0F1B103MQ0T0SHN0	50V-Y5V-103M	CT1
30		F05B1B103KQ0T0SHN0	50V-Y5P-103K	CT1
31		F05F1B473ZQ0T0SHN0	50V-Y5V-473Z	CS1
32		F05F1B473MQ0T0SHN0	50V-Y5V-473M	CS1
33		FC6F1B104ZQ0T0SHN0	50V-Y5V-104Z	CS1
34		FC6F1B104MQ0T0SHN0	50V-Y5V-104M	CS1
35		F06F1B104ZQ0T0SHN0	50V-Y5V-104Z	CS1
36		F06F1B104MQ0T0SHN0	50V-Y5V-104M	CS1
37		F08F1B224ZQ0T0SHN0	50V-Y5V-224Z	CS1
38		F08F1B224MQ0T0SHN0	50V-Y5V-224M	CS1

### Model Description:

- CC1: Temperature Compensating Type, belong to category 1 Porcelain (25VDC~250VDC)。
- CT1: High Dielectric Constant Type, belong to category 2 Porcelain (25VDC~250VDC)。
- CS1: Semiconductor Type, belong to category 2 Porcelain (16VDC~50VDC)。





# Low voltage ceramic capacitors up to 500V

NO.	STE-WI-001-01	Date	2019-01-21
Ver.	V 1.0	Page	Page 5 of 15

## Directory

1. Part NO.Explain.....	5
2. Admit specifications.....	7
3. Product description.....	7
4. Marking.....	8
5. Reference Standard.....	8
6. Electrical characteristics and Reliability test.....	8
7. Packaging.....	13
8. Storage conditions.....	13
9. Tape icon and size chart.....	13





# Low voltage ceramic capacitors up to 500V

NO.	STE-WI-001-01	Date	2019-01-21
Ver.	V 1.0	Page	Page 6 of 15

## 1.Part NO.Explain

### 1.1.Part number eighteen

Coding 18 digits	F	05	B	1	B	102	K	N0	B	0	S	H	N	0
Number of segments10 segments	(1)	(2)	(3)	(4)	(5)	(6)	(7)	(8)	(9)	(10)				

### 1.2.Coded representation meaning

(1) segment、No (1) code - Rated voltage

code	Rated voltage	code	Rated voltage
D	16VDC	H	100VDC
E	25VDC	K	250VDC
F	50VDC	L	500VDC
J	63VDC		

(2) Segment、No. (2、3) digits- Finished product diameter code

code	04	05	06	07	08	09	10
The finished diameter	4.0 mm	5.0mm	6.0 mm	7.0 mm	8.0 mm	9.0 mm	10.0 mm
code	11	12	13	14	C0	C4	C6
The finished diameter	11.0 mm	12.0 mm	13.0 mm	14.0 mm	5.0mm	5.4mm	5.6mm

Note: The size of the film is rounded to the rules of naming.

(3) Segment、No (4) digit - Temperature coefficient and temperature characteristics

Code	A	S	B	E	F
Temperature coefficient	NPO	SL	Y5P	Y5U	Y5V
Note	CC1		CT1	CT1、CS1	

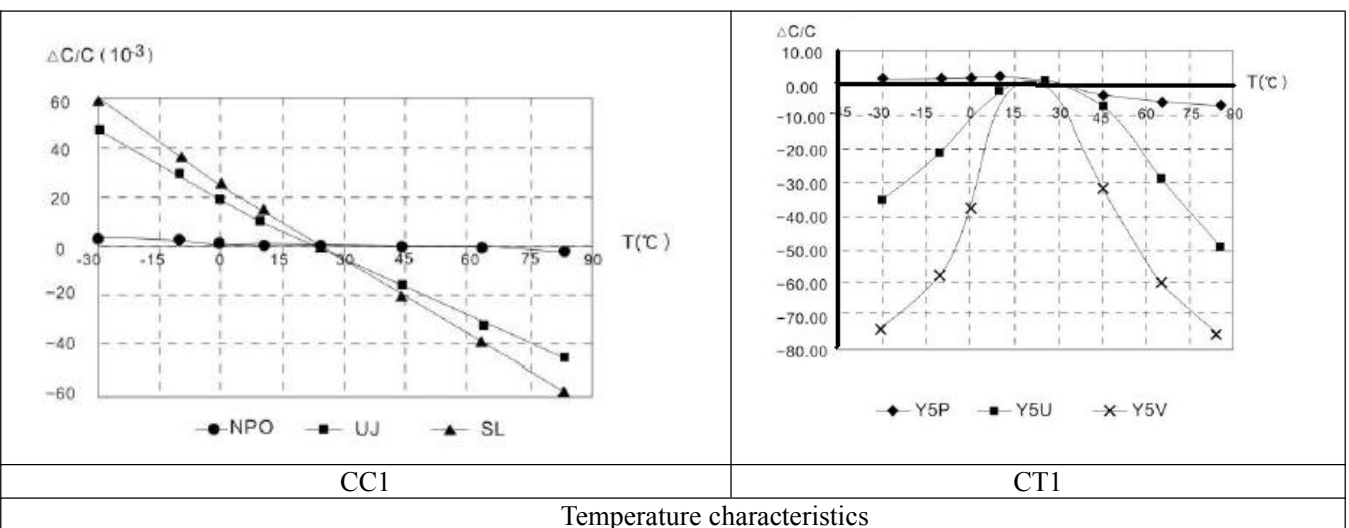



Low voltage ceramic capacitors up to 500V

NO.	STE-WI-001-01	Date	2019-01-21
Ver.	V 1.0	Page	Page 7 of 15

(4) Segment、No (5) digit- Lead type

Schematic diagram of sample					
	Long straight lead	Outside kink lead	Short straight lead	inside kink lead	Front and rear feet lead
Code	1	2	3	4	8

(5) Segment、No (6) digit - Lead spacing

code	A	B	E	D
Pin spacing	2.5mm	5.0mm	7.5mm	10.0mm

(6) Segment、No (7、8、9) digit- Nominal capacitance

code	4R7	1R0	470	471	102	472	103	104
Nominal capacity	4.7pF	1pF	47pF	470pF	1nF	4.7nF	10nF	0.1μF

Note: the nominal capacity is represented by three digits, and the unit is pF, and its significance for the first, two digits are significant, third said the first two digits of the number zero back; if the capacity is less than 10PF and the decimal, fractional R.

(7) Segment、No(10)digit - Capacitance tolerance

Code	C	D	F	G	J	K	M	S	Z	P
Tol.	±0.25pF	±0.5pF	±1.0pF	±2.0%	±5%	±10%	±20%	-20/+50%	-20/+80%	-0/+100%
Scope	Below 10pF					Above 10pF				

(8) Segment、No(11、12)digit - Lead Length

Code	Lead Length (mm)	Code	Lead Length (mm)	Remark
X0-X9	2.0-2.9	F0-F9	8.0-8.9	
A0-A9	3.0-3.9	G0-G9	9.0-9.9	
B0-B9	4.0-4.9	H0-H9	10.0-10.9	
C0-C9	5.0-5.9	N0	Bulk:16.0~27.0 Taping:H0=16.5	
D0-D9	6.0-6.9	P0	H0=17	Taping
E0-E9	7.0-7.9	Q0	H=20	Taping





## Low voltage ceramic capacitors up to 500V

NO.	STE-WI-001-01	Date	2019-01-21
Ver.	V 1.0	Page	Page 8 of 15

(9) Segment、No (13)digit- Packing way

Code	Meaning
B	bulk
T	tape

(10) Segment、No (14、15、16、17、18) digit- Internal management code

### 2.Admit specifications

NO.	Part No.	Part No. Of STE	Demension (mm)						
			D±1.0	T±1.0	L±0.5	F±0.8	d±0.05	c Max	Packing
1		F05S1B101KN0B0SHN0	5.0	2.5	16.0	5.0	0.4	2.0	Bulk
2		F05B1B221KN0B0SHN0	5.0	2.5	16.0	5.0	0.4	2.0	Bulk
3		F05B1B331KN0B0SHN0	5.0	2.5	16.0	5.0	0.4	2.0	Bulk
4		F05B1B471KN0B0SHN0	5.0	2.5	16.0	5.0	0.4	2.0	Bulk
5		F05B1B681KN0B0SHN0	5.0	2.5	16.0	5.0	0.4	2.0	Bulk
6		F05B1B102KN0B0SHN0	5.0	2.5	16.0	5.0	0.4	2.0	Bulk
7		F05B1B222KN0B0SHN0	5.0	2.5	16.0	5.0	0.4	2.0	Bulk
8		F05F1B472MN0B0SHN0	5.0	2.5	16.0	5.0	0.4	2.0	Bulk
9		F05B1B472KN0B0SHN0	5.0	2.5	16.0	5.0	0.4	2.0	Bulk
10		F05F1B103MN0B0SHN0	5.0	2.5	16.0	5.0	0.4	2.0	Bulk
11		F05B1B103KN0B0SHN0	5.0	2.5	16.0	5.0	0.4	2.0	Bulk
12		F05F1B473ZN0B0SHN0	5.0	2.5	16.0	5.0	0.4	2.0	Bulk
13		F05F1B473MN0B0SHN0	5.0	2.5	16.0	5.0	0.4	2.0	Bulk
14		FC6F1B104ZN0B0SHN0	5.6	2.5	16.0	5.0	0.4	2.0	Bulk
15		FC6F1B104MN0B0SHN0	5.6	2.5	16.0	5.0	0.4	2.0	Bulk
16		F06F1B104ZN0B0SHN0	6.0	2.5	16.0	5.0	0.4	2.0	Bulk
17		F06F1B104MN0B0SHN0	6.0	2.5	16.0	5.0	0.4	2.0	Bulk
18		F08F1B224ZN0B0SHN0	8.0	2.5	16.0	5.0	0.5	2.0	Bulk
19		F08F1B224MN0B0SHN0	8.0	2.5	16.0	5.0	0.5	2.0	Bulk
20		F05S1B101KQ0T0SHN0	5.0	2.5	/	5.0	0.5	2.0	Taping
21		F05B1B221KQ0T0SHN0	5.0	2.5	/	5.0	0.5	2.0	Taping
22		F05B1B331KQ0T0SHN0	5.0	2.5	/	5.0	0.5	2.0	Taping
23		F05B1B471KQ0T0SHN0	5.0	2.5	/	5.0	0.5	2.0	Taping
24		F05B1B681KQ0T0SHN0	5.0	2.5	/	5.0	0.5	2.0	Taping
25		F05B1B102KQ0T0SHN0	5.0	2.5	/	5.0	0.5	2.0	Taping
26		F05B1B222KQ0T0SHN0	5.0	2.5	/	5.0	0.5	2.0	Taping







Low voltage ceramic capacitors up to 500V

NO.	STE-WI-001-01	Date	2019-01-21
Ver.	V 1.0	Page	Page 9 of 15

27	F05F1B472MQ0T0SHN0	5.0	2.5	/	5.0	0.5	2.0	Taping
28	F05B1B472KQ0T0SHN0	5.0	2.5	/	5.0	0.5	2.0	Taping
29	FC0F1B103MQ0T0SHN0	5.0	2.5	/	5.0	0.5	2.0	Taping
30	F05B1B103KQ0T0SHN0	5.0	2.5	/	5.0	0.5	2.0	Taping
31	F05F1B473ZQ0T0SHN0	5.0	2.5	/	5.0	0.5	2.0	Taping
32	F05F1B473MQ0T0SHN0	5.0	2.5	/	5.0	0.5	2.0	Taping
33	FC6F1B104ZQ0T0SHN0	5.6	2.5	/	5.0	0.5	2.0	Taping
34	FC6F1B104MQ0T0SHN0	5.6	2.5	/	5.0	0.5	2.0	Taping
35	F06F1B104ZQ0T0SHN0	6.0	2.5	/	5.0	0.5	2.0	Taping
36	F06F1B104MQ0T0SHN0	6.0	2.5	/	5.0	0.5	2.0	Taping
37	F08F1B224ZQ0T0SHN0	8.0	2.5	/	5.0	0.5	2.0	Taping
38	F08F1B224MQ0T0SHN0	8.0	2.5	/	5.0	0.5	2.0	Taping

3.Product description

<p>Note: the encapsulation are of two ways: one is epoxy resin coating seal, color to yellow.</p>	
<p>Structure</p>	<p>Dimension diagram</p>





## Low voltage ceramic capacitors up to 500V

NO.	STE-WI-001-01	Date	2019-01-21
Ver.	V 1.0	Page	Page 10 of 15

### 4. Marking

Level	Example	Remarks	
	①Company logo	<250V P=2.5mm&P=5.0mm  The following exceptions apply: 1、 103,104 (片径 5.6mm) 2、 222 ( P≠2.5mm of Parts products)	
	②indicates that the nominal capacity		104
	③indicates that the rated voltage		-
	①Company logo	1、 103,104 (Trail 5.6mm) 2、 222 (P≠2.5mm of Parts products)	
	②indicates that the nominal capacity		104
	①Company logo	>250V P=5.0mm	
	②indicates that the nominal capacity		102
	③indicates that the rated voltage		250V

Note: The above marked for the Division I regular printing, special requirements for marking separately.

### 5.Reference Standard

This acknowledgment is based on GB / T 2693-2001、 GB/T5968-1996 , GB11305-89and the other part of the standard which is a reference to the relevant sections of EIA or JIS standards drawn up.

### 6.Electrical characteristics and Reliability test

Test conditions: testing and testing must be in standard conditions ( mean temperature of 15 ~ 35 °C , 45 ~ 85% relative humidity, atmospheric86 ~ 106Kpa ) 。 Unless otherwise indicated, capacitors must be tested under the reference conditions (temperature 25 ± 2 ° C, relative humidity 65%, air pressure 101.3 kPa) in case of doubt and special requirements on the measurement results.

#### 6.1 Electrical characteristics

No.	Item	Specification	Testing Method
1	Temperature range	-25°C ~ 85°C	
2	Appearance	No marked defect on appearance form	Visually inspected。
3	Marking	To be easily legible。	Visually inspected。





Low voltage ceramic capacitors up to 500V

NO.	STE-WI-001-01	Date	2019-01-21
Ver.	V 1.0	Page	Page 11 of 15

No.	Item	Specification	Testing Method												
4	Capacitance	Within specified tolerance.	CC1: CR≤1000PF: 25°C、1±0.1MHZ、1.0Vrms; CR>1000PF;25°C、1±0.1KHZ、1.0Vrms。												
5	(D.F.) Dissipation Factor	CC1: CR≥50, DF≤15*×10 <sup>-4</sup> 5≤CR<50,DF≤1.5× (150/ CR) +7 CT1:DF≤2.5% CS1: Y5P: ≤3.5%; Y5U、Y5V: ≤5.0%	CT1: CR≤100PF;25°C、1±0.1MHZ、1.0Vrms; CR>100PF;25°C、1±0.1KHZ、1.0Vrms CS1: 25°C、1±0.1KHZ、0.1Vrms。												
6	(I.R.) Insulation Resistance	CC1: ≥10000MΩ CT1: CR≤25nF; ≥4000MΩ CR>25nF; Rj·CR≥100s CS1: CR≤25nF; ≥1000MΩ CR>25nF; Rj·CR≥25s Note: "s" for the time constant, that is, insulation resistance times the capacitance, in units of seconds, also known as megohm • micro method.	The voltage should be added directly to the specified value for a duration of 1 min ± 5 s. For batch-by-batch inspections, if the insulation resistance reaches the required value, the test can be completed in a shorter time. The capacitor should be fully discharged before taking measurements. The charging current should not exceed 50mA. <table border="1"> <thead> <tr> <th>Type</th> <th>CC1、CT1</th> <th colspan="2">CS1</th> </tr> </thead> <tbody> <tr> <td>Rated voltage (UR)</td> <td>&lt;500V</td> <td>&lt;50V</td> <td>≥50V</td> </tr> <tr> <td>Voltage proof (VDC)</td> <td>UR</td> <td>UR</td> <td>50V</td> </tr> </tbody> </table>	Type	CC1、CT1	CS1		Rated voltage (UR)	<500V	<50V	≥50V	Voltage proof (VDC)	UR	UR	50V
Type	CC1、CT1	CS1													
Rated voltage (UR)	<500V	<50V	≥50V												
Voltage proof (VDC)	UR	UR	50V												
7	(T.V.) Voltage proof	Requirements: during the trials capacitor should be no breakdown or fly arc.	Test conditions: The spec provides the following capacitor voltage is applied between the terminations for the identification of the approval and periodic tests applied voltage time 1min, quality and consistency of the batch test for the applied voltage time 2s . Following table provides an applied voltage; charge current should not exceed 0.05A. Set 0.50mA leakage current. <table border="1"> <thead> <tr> <th>Type</th> <th>CC1、CT1</th> <th>CS1</th> </tr> </thead> <tbody> <tr> <td>Rated voltage (UR)</td> <td>≤500V</td> <td>&lt;100V</td> </tr> <tr> <td>Voltage proof (VDC)</td> <td>2.5UR</td> <td>1.5UR</td> </tr> </tbody> </table> <p>Note: if the customer has special requirements or the size of special specifications, then according to customer special requirements or special requirements for testing</p>	Type	CC1、CT1	CS1	Rated voltage (UR)	≤500V	<100V	Voltage proof (VDC)	2.5UR	1.5UR			
Type	CC1、CT1	CS1													
Rated voltage (UR)	≤500V	<100V													
Voltage proof (VDC)	2.5UR	1.5UR													

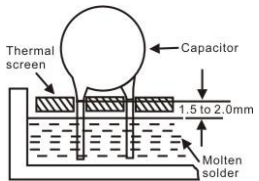
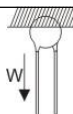

### 6.2 Reliability test

No.	Item	Specification	Testing Method																								
8	Temperature Characteristics	<table border="1"> <tr> <th>Char.</th> <th>Capacitance Change</th> </tr> <tr> <td>NPO</td> <td>0±60 ppm/°C</td> </tr> <tr> <td>SL</td> <td>+100,-1000 ppm/°C</td> </tr> <tr> <td>Y5P</td> <td>±10%</td> </tr> <tr> <td>Y5U</td> <td>+22/-56%</td> </tr> <tr> <td>Y5V</td> <td>+30/-80%</td> </tr> </table> <p>Temp. range: -25 ~ +85°C</p>	Char.	Capacitance Change	NPO	0±60 ppm/°C	SL	+100,-1000 ppm/°C	Y5P	±10%	Y5U	+22/-56%	Y5V	+30/-80%	<p>The capacitance measurement should be made at each step specified in Table 3.</p> <p>&lt;Table 3.&gt;</p> <table border="1"> <tr> <th>Step</th> <th>1</th> <th>2</th> <th>3</th> <th>4</th> <th>5</th> </tr> <tr> <td>Temperature(°C)</td> <td>20 ±2</td> <td>-25 ±2</td> <td>20 ±2</td> <td>85 ±2</td> <td>20 ±2</td> </tr> </table>	Step	1	2	3	4	5	Temperature(°C)	20 ±2	-25 ±2	20 ±2	85 ±2	20 ±2
Char.	Capacitance Change																										
NPO	0±60 ppm/°C																										
SL	+100,-1000 ppm/°C																										
Y5P	±10%																										
Y5U	+22/-56%																										
Y5V	+30/-80%																										
Step	1	2	3	4	5																						
Temperature(°C)	20 ±2	-25 ±2	20 ±2	85 ±2	20 ±2																						
9	Solderability of Leads	Lead wire should be soldered with uniform coating on the axial direction over 3/4 of the circumferential direction.	<p>The lead wire of a capacitor should be dipped into molten solder for 2±0.5 sec. The depth of immersion is up to about 1.5 to 2.0mm from the root of lead</p> <p>Temp. of solder: Lead Free Solder (Sn-2Ag-0.5Cu) 260±5°C.</p>																								
10	Soldering Effect	<p>Appearance: No marked defect</p> <p>Capacitance Change:            CC1:            +100≥α≥-750: ±0.5% or ±0.5pF (Take the larger than the above)            -750&gt;α≥-1500: ±1% or ±1pF (Take the larger than the above)            α&gt;-5600: ±3% or ±1PF (Take the larger than the above)            CT1、CS1:            Y5P: ±10%;            Y5U、Y5V: ±20%。</p>	<p>As in figure , the lead wires should be immersed in solder of 260±5°C up to 1.5 to 2.0mm from the terminal for 10.0±0.5 sec.。</p> 																								
11	Robustness of Terminations	<p>pull</p> <p>bending</p> <p>Lead wire should not be cut off. Capacitor should not be broken.</p>	<p>As shown in the figure at right, fix the body of the capacitor and apply a tensile weight gradually to each lead wire in the radial direction of the capacitor up to as follows and keep it for 10±1 sec.</p>  <table border="1"> <tr> <th>Diameter(mm)</th> <th>Minimum tension (N)</th> </tr> <tr> <td>0.35 &lt; d ≤ 0.5</td> <td>5±10%</td> </tr> <tr> <td>0.5 &lt; d ≤ 0.8</td> <td>10±10%</td> </tr> <tr> <td>0.8 &lt; d ≤ 1.25</td> <td>20±10%</td> </tr> </table> <p>Each lead wire should be subjected to 5N weight and then a 90° bend, at the point of egress, in one direction, return to original position, and then apply a 90° bend in the opposite direction at the rate of one bend in 2 to 3 sec, For a cycle, a total of 22 cycles.</p> <table border="1"> <tr> <th>Diameter(mm)</th> <th>Minimum tension (N)</th> </tr> <tr> <td>0.35 &lt; d ≤ 0.5</td> <td>2.5±10%</td> </tr> <tr> <td>0.5 &lt; d ≤ 0.8</td> <td>5±10%</td> </tr> <tr> <td>0.8 &lt; d ≤ 1.25</td> <td>10±10%</td> </tr> </table>	Diameter(mm)	Minimum tension (N)	0.35 < d ≤ 0.5	5±10%	0.5 < d ≤ 0.8	10±10%	0.8 < d ≤ 1.25	20±10%	Diameter(mm)	Minimum tension (N)	0.35 < d ≤ 0.5	2.5±10%	0.5 < d ≤ 0.8	5±10%	0.8 < d ≤ 1.25	10±10%								
Diameter(mm)	Minimum tension (N)																										
0.35 < d ≤ 0.5	5±10%																										
0.5 < d ≤ 0.8	10±10%																										
0.8 < d ≤ 1.25	20±10%																										
Diameter(mm)	Minimum tension (N)																										
0.35 < d ≤ 0.5	2.5±10%																										
0.5 < d ≤ 0.8	5±10%																										
0.8 < d ≤ 1.25	10±10%																										

  
 承认书专用章



Low voltage ceramic capacitors up to 500V

NO.	STE-WI-001-01	Date	2019-01-21
Ver.	V 1.0	Page	Page 13 of 15

No.	Item	Specification	Testing Method															
12	Rapid changes in temperature	Appearance	Capacitors should be tested in the order shown in the following table (for one cycle) for five consecutive cycles. <table border="1" style="margin: 10px 0;"> <thead> <tr> <th>Step</th> <th>Temperature (°C)</th> <th>Time (min)</th> </tr> </thead> <tbody> <tr> <td>1</td> <td>-25</td> <td>30</td> </tr> <tr> <td>2</td> <td>+25</td> <td>3</td> </tr> <tr> <td>3</td> <td>+85</td> <td>30</td> </tr> <tr> <td>4</td> <td>+25</td> <td>3</td> </tr> </tbody> </table> [Pre-treatment]: Capacitor should be stored at 85±2°C for 1 hr., then placed at room condition for 24±2 hrs. [Post-treatment]: Capacitor should be stored for 24±2 hrs. at room condition.	Step	Temperature (°C)	Time (min)	1	-25	30	2	+25	3	3	+85	30	4	+25	3
		Step		Temperature (°C)	Time (min)													
		1		-25	30													
		2		+25	3													
3	+85	30																
4	+25	3																
Capacitance Change	NP0 : Capacitance changes ≤2% or 1pF, Take the larger one . SL: Capacitance changes ≤3% or 1 pF, Take the larger one . Y5P: ΔC/C ≤10%; Y5U: ΔC/C ≤20% Y5V: ΔC/C ≤30%																	
D.F.	SL/NP0: Less than or equal to 2 times the initial value. Y5P: tanδ ≤5%; Y5U/Y5V: tanδ ≤7%																	
IR	SL/NP0: ≥2500MΩ or 25s, Whichever is smaller. Y5P/Y5U/Y5V: Ri ≥1000MΩ or Ri·CR ≥25s, Whichever is smaller.																	
13	Steady state damp heat	Appearance	Test conditions: 1) half of the sample to impose UR, the other half is not the applied voltage, charge current should not exceed 50mA. 2) Temperature: 40 ± 2 °C; relative humidity: 95 ± 2%. 3) continued 500h +24 /-0h.															
		Capacitance Change		NP0 : Capacitance changes ≤2% or 1pF, Take the larger one . SL: Capacitance changes ≤3% or 1pF, Take the larger one . Y5P: ΔC/C ≤10%; Y5U: ΔC/C ≤20% Y5V: ΔC/C ≤30%														
		D.F.		SL/NP0: Less than or equal to 2 times the initial value. Y5P: tanδ ≤5% Y5U/Y5V: tanδ ≤7%														
		IR		SL/NP0: ≥2500MΩ or 25s, Whichever is smaller Y5P/Y5U/Y5V: Ri ≥1000MΩ or Ri·CR ≥25s, Whichever is smaller.														
14	Durability	Appearance	Test conditions: 1) temperature: the upper category temperature. 2) Voltage: CC1/CT1 1.5UR.CS1: 1.25UR Charge current should not exceed 50mA. 3) Duration: 1000h +48 /-24h. [Post-processing test]: the standard atmospheric conditions at least 24 hours after recovery, measuring electrical properties.															
		Capacitance Change		CC1: NP0: Capacitance changes ≤3% or 1pF, Take the larger one. SL: Capacitance changes ≤5% or 1pF, Take the larger one. CT1: Y5P/Y5U: ΔC/C ≤20%; Y5V: ΔC/C ≤30% CS1: ΔC/C ≤30%														
		DF		CC1: SL/NP0: Less than or equal to 1.5 times the initial value CT1: Y5P: tanδ ≤5%; Y5U/Y5V: tanδ ≤7% CS1: ≤0.1														
		IR		CC1: SL/NP0: ≥4000MΩ or 40s, Whichever is smaller. CT1: Y5P/Y5U/Y5V: Ri ≥2000MΩ or Ri·CR ≥50s, Whichever is smaller. CS1: Ri ≥700MΩ or Ri·CR ≥17.5s.														





Low voltage ceramic capacitors up to 500V

NO.	STE-WI-001-01	Date	2019-01-21
Ver.	V 1.0	Page	Page 14 of 15

7. Packaging

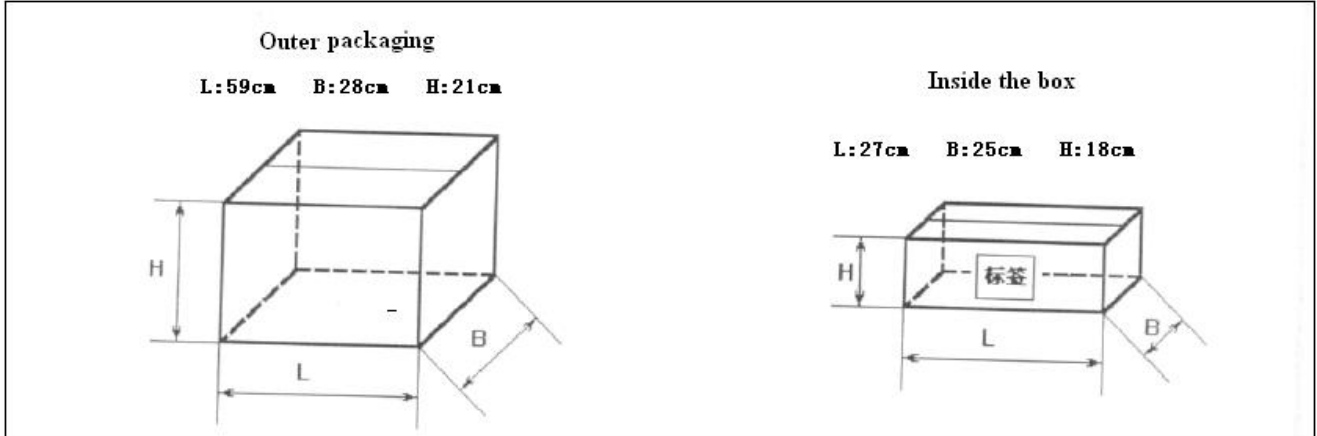

Note: the above of packages for reference only.

折叠式  
Taping/Ammo

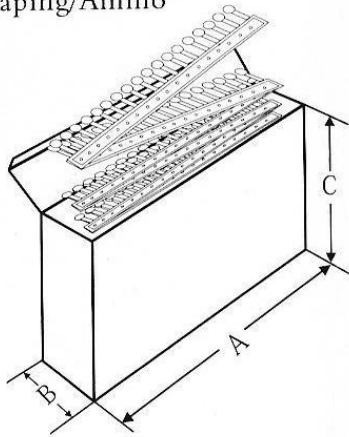

Size description.:		
A	B	C
33.5cm	4.4cm	26.2cm

Packing quantity:

Part No.	Number (PCS/bag)
∅ 8 the following (Including 8)	1000
∅ 8 the above	500
Tape	2000/box

Note: The above quantity is for reference only.





## Low voltage ceramic capacitors up to 500V

NO.	STE-WI-001-01	Date	2019-01-21
Ver.	V 1.0	Page	Page 15 of 15

### 8.Storage conditions

8.1 Because of the presence of hydrogen chloride, hydrosulfide, sulfuric acid, etc. in the atmosphere, when the product is stored in the atmosphere, we must take care that the lead-out end has poor solderability.

8.2 The product can not be exposed to high temperature and high humidity and must be stored in the following environment: (on the basis of not disassembling the original packaging)

A、Storage temperature:  $\leq 35^{\circ}\text{C}$

B、Relative Humidity:  $\leq 70\%RH$

C、Period of storage:  $\leq 1$  year (Count from the date on the product package or on the product body)

### 9.Tape icon and size chart(Only for taping products)

NO



## X-ON Electronics

Largest Supplier of Electrical and Electronic Components

*Click to view similar products for [Ceramic Disc Capacitors](#) category:*

*Click to view products by [Songtian](#) manufacturer:*

Other Similar products are found below :

[009377XM](#) [5AS560JCFCA](#) [5AU100JCECA](#) [5AU470JCJCA](#) [DEF2CLH020CA3B](#) [HSE102MAQBF0KR](#) [432202101621](#) [432202282431](#)  
[DEF2CLH030CJ3B](#) [W1X223MCVCF0KR](#) [564RC0GBA302EJ470K](#) [5AS270JCDCA](#) [5AS330JCDCA](#) [5AU330JCGCA](#)  
[DE1E3KX222MJ4BN01F](#) [440LT68AP-R](#) [JN222MQ47FAAAAKPLP](#) [H8000090-245](#) [H8000090-225RY](#) [H8000090-309RY](#) [H8000090-](#)  
[291RY](#) [F471K39S3NR63K7R](#) [DEF2CLH040CN3A](#) [DEF2CLH080DA3B](#) [564R3DF0T22](#) [CC2150KY5P1KVB5LS-LF](#)  
[CC2180KY5P1KVB5LS-LF](#) [CC2470KY5P1KVB5LS-LF](#) [CC2820KY5P1KVB5LS-LF](#) [0838-040-X7R0-220K](#) [JN102MQ35FAAAAKPLP](#)  
[0841-040-X5U0-103M](#) [CCH-6K8-5/1000V](#) [140-50N2-101J-TB-RC](#) [ECK-DGL102ME](#) [562R5GAD47RR](#) [S103K75Y5PN8BT0R](#)  
[615R100GAD10](#) [615R150GAD10](#) [NCD100K1KVSLF](#) [NCD682M1KVZ5UF](#) [CCK-100N](#) [CCK-100P](#) [CCK-22N](#) [CCK-2N2](#) [CCK-47N](#) [CCK-](#)  
[47P](#) [CCK-4N7](#) [CCK-4P7](#) [CK45-B3FD681KYNNA](#)