

# 10 White LED Boost Converter with PWM Dimming and Single-Wire Series Interface

## DESCRIPTION

The EUP2530 is a constant current step-up converter specifically designed to drive white LEDs. With a 45V rated integrated switch FET, the step-up converter supports up to 10 white LEDs in series connection, so the LED currents are identical for uniform brightness. The boost converter runs at 1.0MHz fixed switching frequency with 1.3A switch current limit, and allows for the use of a high brightness LED in general lighting. The maximum white LED current is set with the external sensor resistor  $R_{FB}$ , and the feedback voltage is regulated to 200mV, as shown in the typical application. During the operation, the LED current can be controlled through the EN pin in two modes. With a 8KHz or higher frequency PWM dimming signal on EN pin, EUP2530 operates in PWM dimming mode, which the duty cycle determines the feedback reference voltage. EUP2530 can operate in digital dimming mode also, which a Single Wire interface on the EN pin is integrated to adjust the FB voltage in 32 steps. In either digital or PWM mode, the EUP2530 does not generate audible noises on the output capacitor. For the protection, the EUP2530 provides 41.5V OVP to prevent damage from LED open.

The EUP2530 is available in low profile TSOT23-6 and SOT23-6 packages.

## Typical Application Circuit

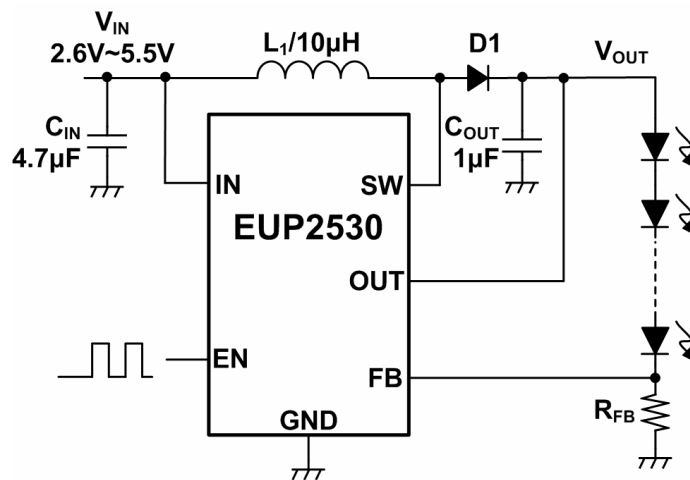

Figure 1. White LED Application

## FEATURES

- 2.6V to 5.5V Input Range
- 41.5V Output Over Voltage Protection
- Internal Soft-Start
- Internal Compensation
- Single-Wire Serial Pulse Interface to Set LED Current with 32-Step Scale
- External PWM Dimming with 8KHz - 300KHz Frequency Range
- Internal 45V N-FET
- 1MHz Fixed Switching Frequency
- Over Voltage Protection
- Over Thermal Protection
- $V_{IN}$  Under Voltage LockOut
- Available in TSOT23-6 and SOT23-6 Packages
- RoHS Compliant and 100% Lead (Pb)-Free Halogen-Free

## APPLICATIONS

- Mobile Phones
- GPS Navigation Systems
- Portable Media Players
- Handheld Devices, Digital Camera
- Portable Game Machines

## Pin Configurations

Package Type	Pin Configurations	Package Type	Pin Configurations
TSOT23-6	<p>(TOP VIEW)</p>	SOT23-6	<p>(TOP VIEW)</p>

## Pin Description

PIN	TSOT23-6	SOT23-6	DESCRIPTION
SW	1	1	Switch Pin. This is the drain of the internal power switch. Connect inductor/diode here. Minimize trace area at this pin to reduce EMI.
GND	2	2	Common Ground. Connect the pin to the ground plane.
FB	3	3	Feedback Pin. Reference voltage is 0.2V. Connect cathode of lowest LED and resistor here. Calculate resistor value according to the formula: $R_{FB}=0.2/I_{LED}$
EN	4	4	Enable pin of the boost regulator. It is a multi-functional pin which can be used for enable control, digital and PWM dimming control.
OUT	5	5	Output voltage and over voltage protection.
IN	6	6	Input Supply Voltage.

## Ordering Information

Order Number	Package Type	Marking	Operating Temperature Range
EUP2530OIR1	TSOT23-6	XXXXXX A200	-40 °C to +85°C
EUP2530VIR1	SOT23-6	XXXXXX A200	-40 °C to +85°C

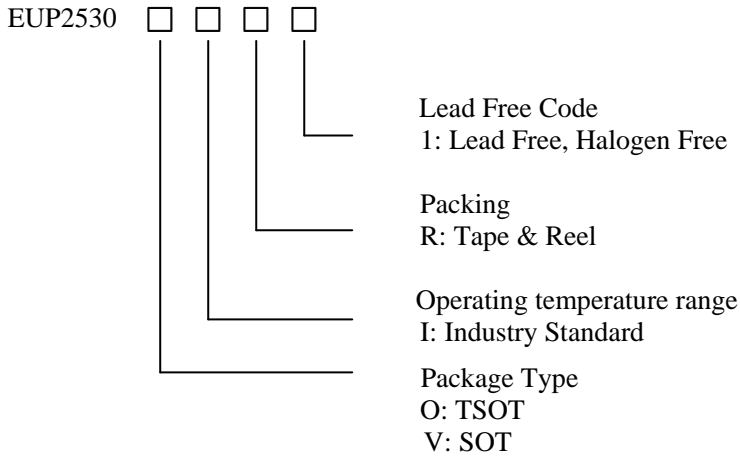

## Block Diagram

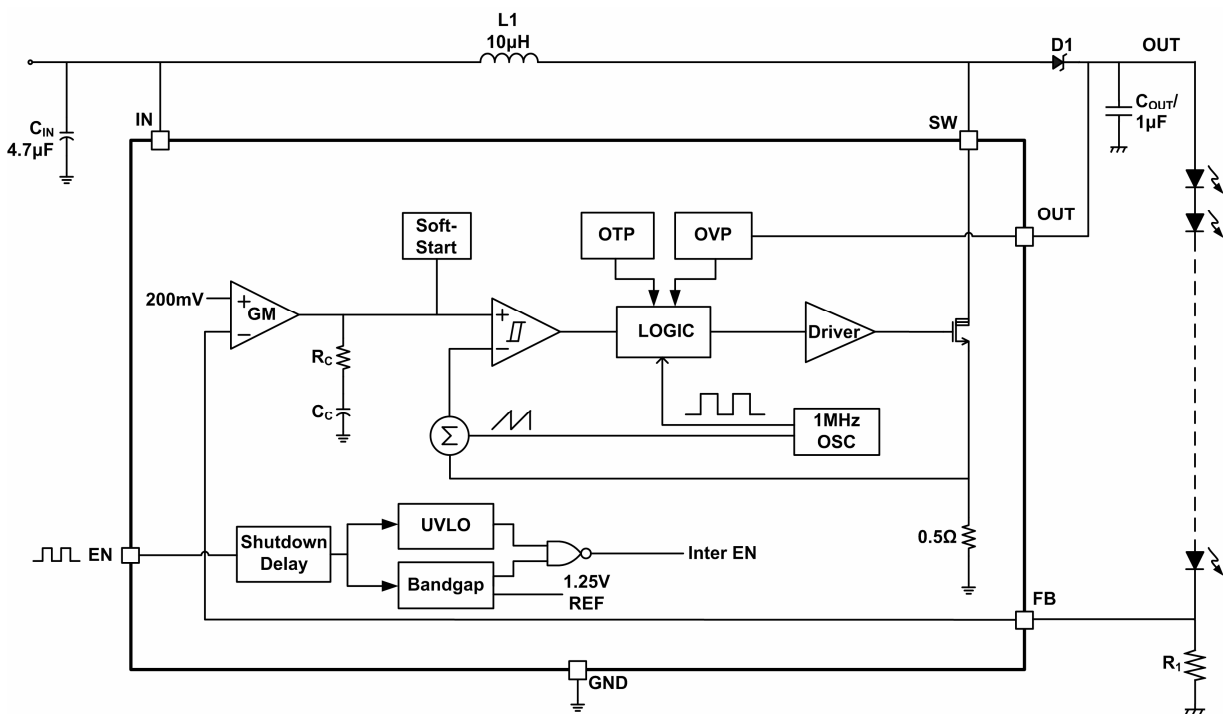

Figure 2.

## Absolute Maximum Ratings (1)

■	IN, EN, FB to GND -----	-0.3V to 6V
■	OUT,SW to GND -----	-0.3V to 45V
■	Power Dissipation, $P_D$ @ $T_A=25^\circ\text{C}$	
	TSOT23-6 -----	0.5W
	SOT23-6 -----	0.488W
■	Package Thermal Resistance	
	TSOT23-6, $\theta_{JA}$ -----	200°C/W
	SOT23-6, $\theta_{JA}$ -----	205°C/W
■	Maximum Junction Temperature -----	125°C
■	Lead Temperature (Soldering, 10sec.) -----	260°C
■	Storage Temperature Range -----	-65°C to +150°C

## Recommend Operating Conditions (2)

■	Operating Temperature Range -----	-40°C to +85°C
■	Supply Voltage , $V_{IN}$ -----	2.6V to 5.5V

Note (1): Stress beyond those listed under “Absolute Maximum Ratings” may damage the device.

Note (2): The device is not guaranteed to function outside the recommended operating conditions.

## Electrical Characteristics

( $V_{IN}=3.6\text{V}$ ,  $V_{OUT}=34\text{V}$ ,  $C_{OUT}=1\mu\text{F}$ ,  $C_{IN}=4.7\mu\text{F}$ ,  $L1=10\mu\text{H}$ ,  $R_{FB}=8\Omega$ ,  $T_A= -40^\circ\text{C}$  to  $+85^\circ\text{C}$ . Unless otherwise noted. Typical values are at  $T_A= +25^\circ\text{C}$ )

Symbol	Parameter	Conditions	EUP2530			Unit
			Min.	Typ.	Max.	
UVLO	Under Voltage Lock Out	Rising	2.0	2.2	2.4	V
	Maximum Output Voltage	No Switching			41	V
$I_{CC1}$	Supply Current	$V_{CC}=3.6\text{V}$ , Continuous Switching		0.75	1.5	mA
$I_{CC2}$	Quiescent Current	$V_{CC}=3.6\text{V}$ , $FB=1.3\text{V}$ , No Switching		300	700	$\mu\text{A}$
$I_{CC3}$	Shutdown Current	$V_{CC}=3.6\text{V}$ , $V_{EN}<0.4\text{V}$		0.1	1	$\mu\text{A}$
<b>Oscillator</b>						
Fosc	Operation Frequency		0.8	1	1.3	MHz
Dmax	Maximum Duty Cycle			92		%
<b>Reference Voltage</b>						
$V_{FB}$	Feedback Voltage		190	200	210	mV
<b>MOSFET</b>						
Rds (on)	On resistance of MOSFET			0.5	0.9	$\Omega$
ILX	Current Limit		1.0	1.3	1.6	A
<b>Control and Protection</b>						
$V_{EN1}$	Shutdown Voltage		0.4	0.6		V
$V_{EN2}$	Enable Voltage			0.8	1.4	V
$R_{EN}$	EN Pin Pull Low Resistance			500	750	K $\Omega$
OVP	OVP Threshold		39	41.5	44	V

## Typical Operating Characteristics

Unless others specified, VIN=3.6V, L=10μH, CIN=4.7μF, COU=1μF, RFB=10ohm, ILED=20mA, LED Array:10S1P

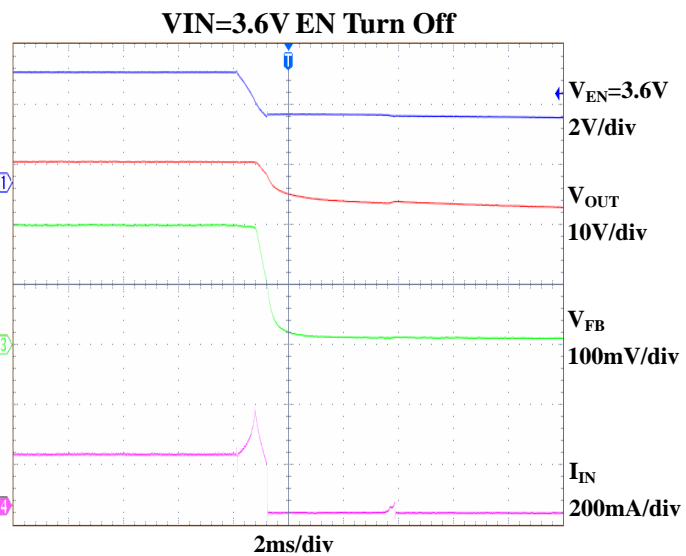
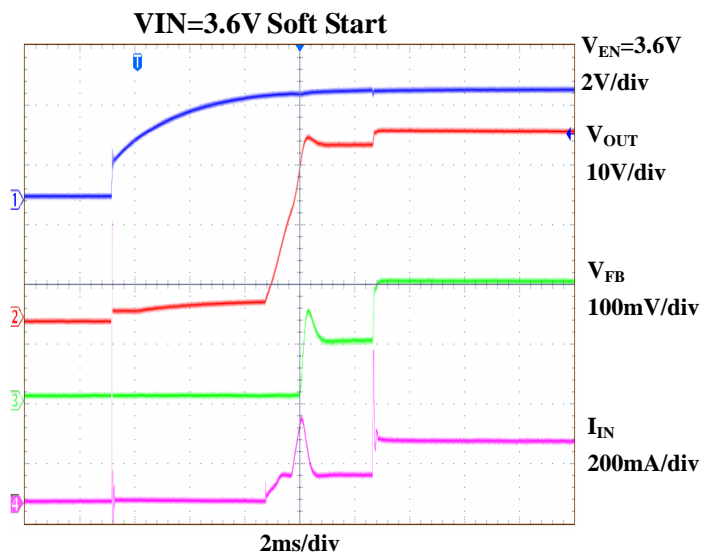
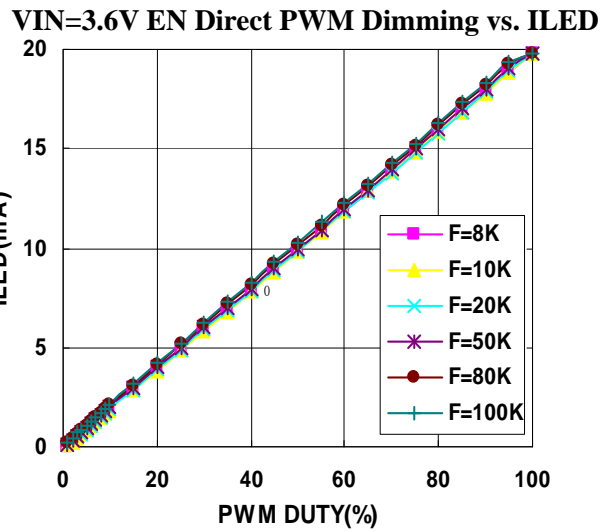
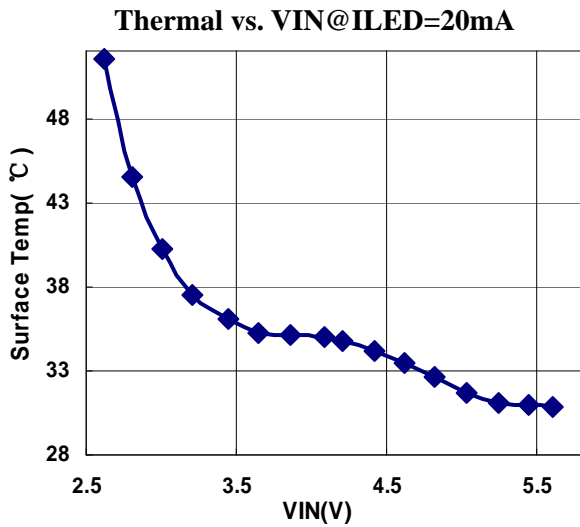
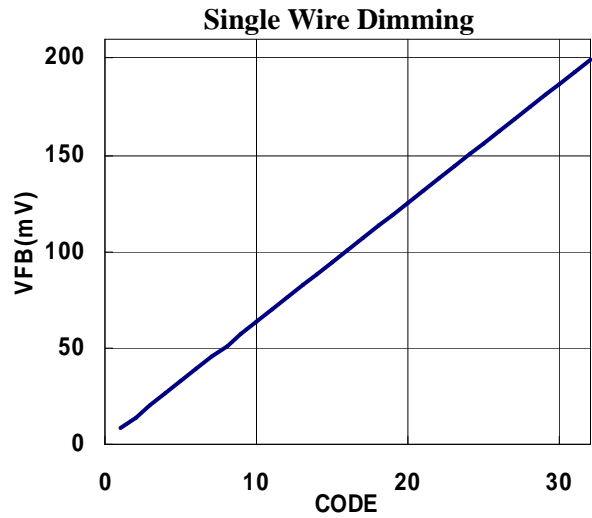
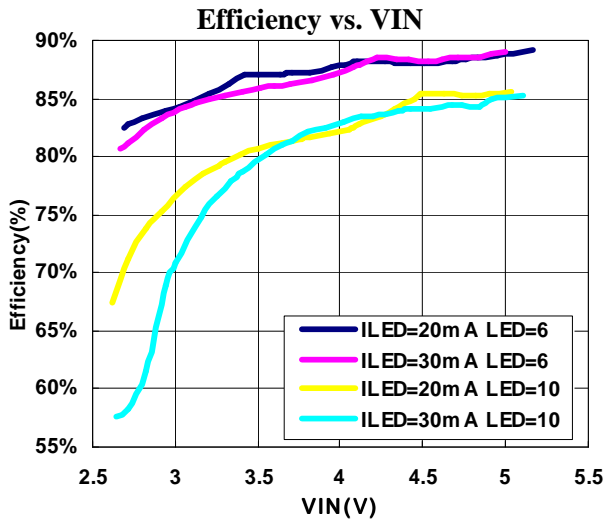

## Typical Operating Characteristics (continued)

Unless others specified,  $V_{IN}=3.6V$ ,  $L=10\mu H$ ,  $C_{IN}=4.7\mu F$ ,  $C_{OUT}=1\mu F$ ,  $R_{FB}=10\Omega$ ,  $I_{LED}=20mA$ ,  
LED Array:10S1P

### LED Open Protection

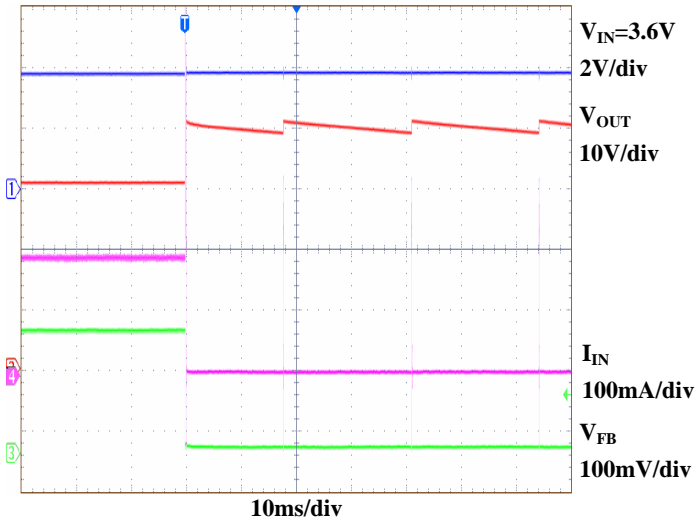

### Steady Operating Characteristic

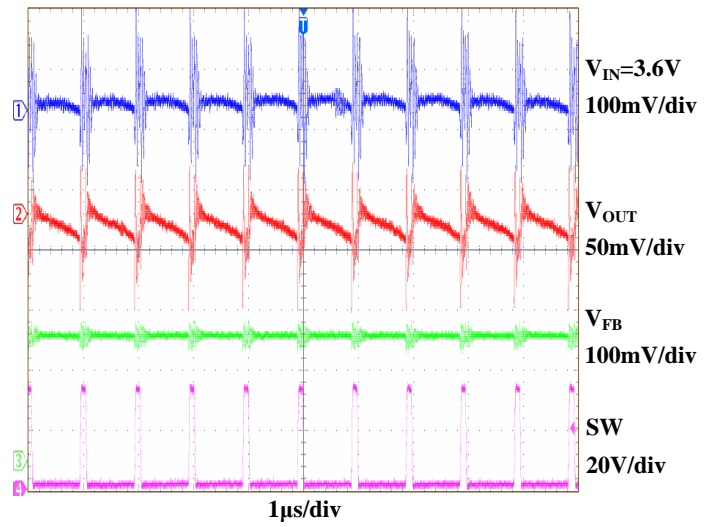

### VIN Line Regulation 3.6V<-->5V

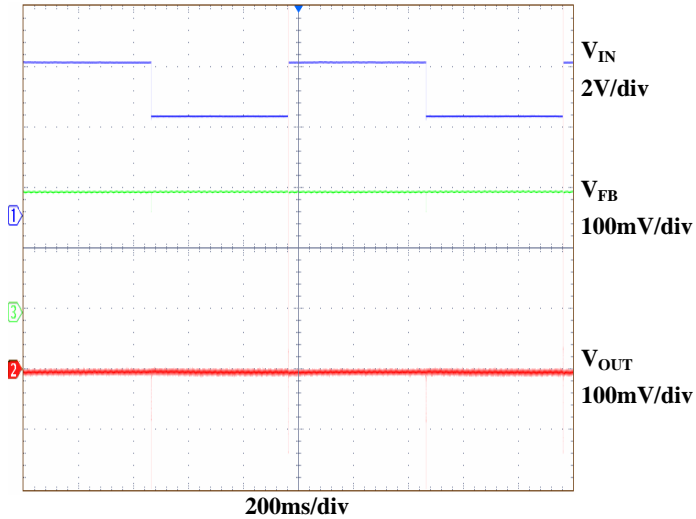

## Application Information

### Soft-Start

Soft-start circuitry is integrated into the IC to avoid a high inrush current during start-up. After the device is enabled, the EUP2530 attain soft-start by reduce the internal GM to 1/20 to limit the start-up duty cycle, which ensures that the output voltage rises slowly to reduce the input current.

### Shutdown

The EUP2530 enter shutdown when EN is less than 0.4V for more than 8mS. In shutdown mode, the input supply current for the device is less than 1μA (max). Although the internal FET does not switch in shutdown, there is still a DC current path between the input and the LEDs through the inductor and Schottky diode. The minimum forward voltage of the LED array must exceed the maximum input voltage to ensure that the LEDs remain off in shutdown.

### OVP/OTP/UVLO/OC

The Over Voltage Protection is detected by an internal resistor divider from OUT to GND. Once V<sub>OUT</sub> goes over the threshold voltage, SW pin stops switching and recover until V<sub>OUT</sub> voltage drops 2.0V.

The Over Thermal Protection will occurs as the junction temperature is higher then 150°C, the chip also will re-enter normal operation when the junction temperature cools to 130°C.

The EUP2530 is also disabled until V<sub>IN</sub> exceeds the UVLO threshold of 2.2V (typ). Hysteresis on UVLO is approximately 0.2V.

The EUP2530 also integrated a 1.3A cycle-to-cycle over current protection to prevent the external component damage.

### LED Current Setting

EUP2530 LED current can be set in two modes through EN pin, PWM dimming and Single Wire dimming. In both dimming modes, LED current is calculated using equation1.

$$I_{LED} = \frac{V_{FB}}{R_{FB}} \quad \text{-----(1)}$$

Where:

I<sub>LED</sub> = output current of LEDs

V<sub>FB</sub> = regulated voltage of FB

R<sub>FB</sub> = current sense resistor

In order to have an accurate LED current, precision resistors are preferred (1% is recommended).

### Led current dimming mode selection

The EN pin is used for the control input for both dimming modes, PWM dimming and the Single Wire dimming. The dimming mode for the EUP2530 is selected each time when the device is enabled. The default dimming mode is PWM dimming. To enter Single

Wire mode, the Figure 4 digital pattern on the EN pin must be recognized by the IC every time the IC starts from the shutdown mode.

1. Pull EN pin high to enable the EUP2530, and to start the Single Wire detection window;
2. EN first high level hold on time between 1mS to 4mS(2.5mS is recommended), EUP2530 will enter Single Wire mode. Otherwise, EUP2530 will operate in PWM Dimming mode;
3. Mode selection window re-starts only after EN pin pull low more than 8mS, and then EN encounter a low to high transition;

### PWM Dimming Control

When the EN pin is constantly high, the FB voltage is regulated to 200mV typically. However, the EN pin allows a PWM signal to reduce this regulation voltage; therefore, it achieves LED brightness dimming. The relationship between the duty cycle and FB voltage is given by equation2.

$$V_{FB} = \text{Duty} \times 200\text{mV} \quad \text{-----(2)}$$

Where:

Duty = duty cycle of the PWM signal

200mV = internal reference voltage

As shown in Figure 3, the IC chops up the internal 200mV reference voltage at the duty cycle of the PWM signal. The pulse signal is then filtered by an internal low pass filter. The output of the filter is connected to the error amplifier as the reference voltage for the FB pin regulation. Therefore, although a PWM signal is used for brightness dimming, only the WLED DC current is modulated, which is often referred as analog dimming. This eliminates the audible noise which often occurs when the LED current is pulsed in replica of the frequency and duty cycle of PWM control. For optimum performance, use the PWM dimming frequency in the range of 8kHz to 300kHz.

But there is an offset in error amplifier which will cause the V<sub>A</sub> variation. In low PWM duty signal situation, the filtered reference voltage is low and the offset can cause bigger variation of the output current, so PWM dimming duty less than 5% is not recommended.

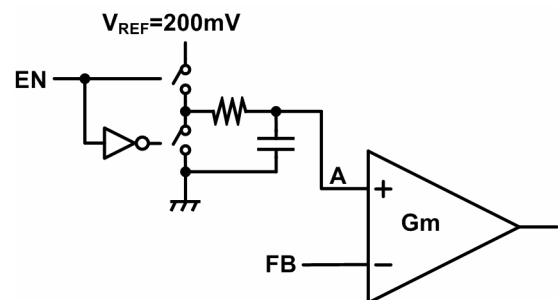
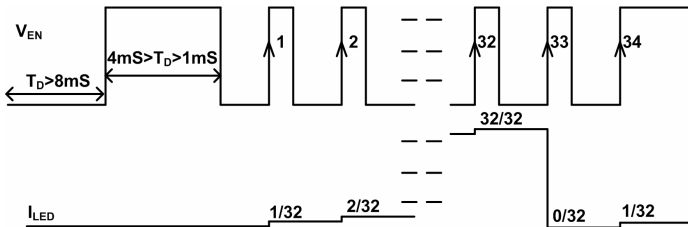

Figure 3. Block Diagram of Programmable FB Voltage Using PWM Signal

## Single Wire Dimming Control

The EN pin also provides a simple digital interface to allow Single Wire dimming control. The digital dimming can save the processor power and battery life as it does not require a PWM signal all the time, and the processor can enter idle mode if available.

The following digital pattern on the EN pin is must be sent for Single Wire dimming operation:



**Figure 4. Single Wire Dimming Signal on EN**

The number of rising edges on EN pin is detected internally and decoded to the current level as illustrated in Table 1 below.

**Table1. Single Wire  $V_{FB}$  Setting**

EN NO.	$V_{FB}$ (mV)	EN NO.	$V_{FB}$ (mV)
1	6.25	17	106.25
2	12.5	18	112.5
3	18.75	19	118.75
4	25	20	125
5	31.25	21	131.25
6	37.5	22	137.5
7	43.75	23	143.75
8	50	24	150
9	56.25	25	156.25
10	62.5	26	162.5
11	68.75	27	168.75
12	75	28	175
13	81.25	29	181.25
14	87.5	30	187.5
15	93.75	31	193.75
16	100	32	200

But there is an offset voltage in error amplifier, which cause  $V_{FB}$  variate from the idea value. So, in low lighting situation, the lowest two codes are not recommended.

## Capacitors Selection

A  $4.7\mu\text{F}$  to  $10\mu\text{F}$  ceramic input capacitor ( $C_{IN}$ ) and a  $1\mu\text{F}$  to  $4.7\mu\text{F}$  ceramic output capacitor ( $C_{OUT}$ ) are sufficient for most applications. During Direct PWM Dimming control, a larger output capacitor will significantly reduce audio noise induced by output capacitor, and a smaller will enlarge the audio noise, a  $1\mu\text{F}$   $C_{OUT}$  is recommended. Under normal condition, a  $4.7\mu\text{F}$  input capacitor is sufficient. For applications with higher output power, a larger input capacitor of  $10\mu\text{F}$  may be appropriate. X5R and X7R capacitor types are ideal due to their stability across temperature range.

## Inductor Selection

The recommended value of inductor for 2 to 10 WLEDs applications are  $4.7\mu\text{H}$  to  $47\mu\text{H}$ . Small size and better efficiency are the major concerns for portable device, such as EUP2530 used for mobile phone. The inductor should have low core loss at 1MHz and low DCR for better efficiency. To avoid inductor saturation current rating should be considered.

## Schottky Diode Selection

The current rating of the Schottky diode must exceed the peak current flowing through it. The Schottky diode performance is rated in terms of its forward voltage at a given current. In order to achieve the best efficiency, this forward voltage should be as low as possible. The response time is also critical since the driver is operating at 1MHz.

## Board Layout

Careful PC board layout is required due to fast switching. All components must be placed as close to the device as possible. Keep the path between the inductor L1, diode D1, and output capacitor  $C_{OUT}$  extremely short for minimal noise and ringing. The feedback components such as the sense resistor  $R_{FB}$  must be kept close to the FB pin to prevent noise injection on the FB pin trace. The ground return of  $C_{IN}$  and  $C_{OUT}$  should be tied close to the GND pin. See the EUP2530 demo board layout for reference.

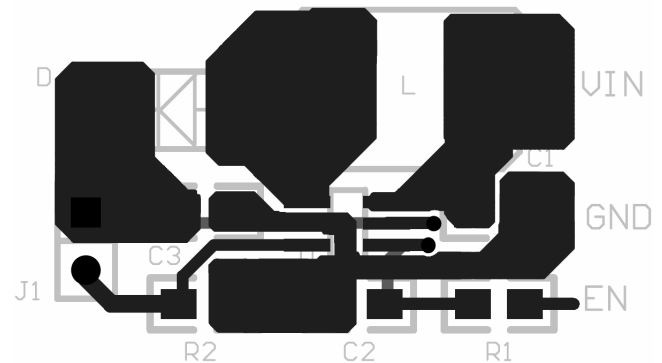
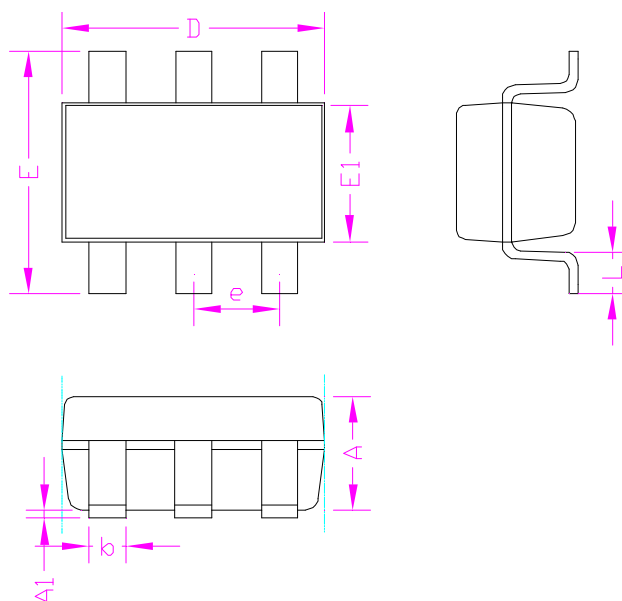

**Figure 5. Demo Board**



**Packaging Information**

**TSOT23-6**



SYMBOLS	MILLIMETERS			INCHES		
	MIN.	Normal	MAX.	MIN.	Normal	MAX.
A	0.70	-	1.00	0.028	-	0.039
A1	0.00	-	0.15	0.000	-	0.006
b	0.30	-	0.50	0.012	-	0.020
D	2.70	2.90	3.10	0.106	0.114	0.122
E1	1.45	1.60	1.75	0.057	0.063	0.069
e	0.95 REF			0.037 REF		
E	2.60	2.80	3.00	0.102	0.110	0.118
L	0.30	-	0.60	0.012	-	0.024

## SOT23-6

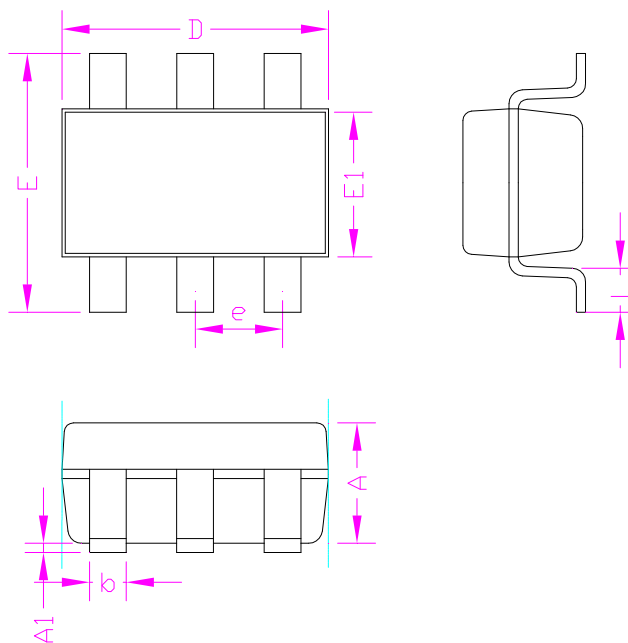

SYMBOLS	MILLIMETERS			INCHES		
	MIN.	Normal	MAX.	MIN.	Normal	MAX.
A	1.00	-	1.45	0.039	-	0.057
A1	0.00	-	0.15	0.000	-	0.006
b	0.30	-	0.50	0.012	-	0.020
D	2.70	2.90	3.10	0.106	0.114	0.122
E1	1.45	1.60	1.75	0.057	0.063	0.069
e	0.95 REF			0.037 REF		
E	2.60	2.80	3.00	0.102	0.110	0.118
L	0.30	-	0.60	0.012	-	0.024

## X-ON Electronics

Largest Supplier of Electrical and Electronic Components

*Click to view similar products for [LED Display Drivers](#) category:*

*Click to view products by [Eutech](#) manufacturer:*

Other Similar products are found below :

[MAP9000QNRH](#) [AP5726WUG-7](#) [AL8806QMP-13](#) [AP5726FDCG-7](#) [AS3693B-ZTQT](#) [AP5725WUG-7](#) [MAX139EQH+D](#) [STP16DP05PTR](#)  
[STP16CPP05PTR](#) [STP16CPP05XTTR](#) [LV5236VZ-TLM-H](#) [BP9911CC](#) [ZXLD1366QEN8TC](#) [MT7725D](#) [TX6143](#) [SY6813PEC](#) [SD1002L4](#)  
[AW3643CSR](#) [MP3370GN-Z](#) [LA2284L-G09-T](#) [SEDA](#) [SCT2027CSSG](#) [LYT3315D](#) [LYT3324D](#) [LYT4211E2](#) [LYT4214E2](#) [LYT4215E2](#)  
[LYT4217E2](#) [LYT4218E2](#) [LYT4222E](#) [LYT4317E2](#) [LYT4321E](#) [LYT4323E](#) [LYT4324E3](#) [LYT4326E3](#) [TPS92020DR](#) [TPS92691PWPR](#)  
[BCR420U](#) [HV9801ALG-G](#) [IS31FL3199-QFLS2-TR](#) [IS31FL3731-QFLS2-TR](#) [CAT4238TD](#) [SCT2001ASIG](#) [SCT2024CSSG](#) [SCT2024CSTG](#)  
[SCT2167CSOG](#) [SCT2167CSSG](#) [STP16CPPS05XTTR](#) [TLE4241GMFUMA1](#) [ICM7212MIQH+D](#)