



## U74HC164

CMOS IC

### 8-BIT SERIAL-IN AND PARALLEL-OUT SHIFT REGISTER

#### DESCRIPTION

The **U74HC164** is an 8-bit edge-triggered shift registers with serial input and parallel output. A LOW-to-HIGH transition on the CP will shifts the data one place to the right which is the logical AND of DSA and DSB.

A Low level on the  $\overline{MR}$  will clear the registers asynchronously and force the outputs LOW.

#### FEATURES

- \* Operation Voltage Range: 2~6V
- \* Asynchronous Reset Input
- \* Specified from -40~ +125°C

#### ORDERING INFORMATION

Ordering Number		Package	Packing
Lead Free	Halogen Free		
U74HC164L-D14-T	U74HC164G-D14-T	DIP-14	Tube
U74HC164L-S14-R	U74HC164G-S14-R	SOP-14	Tape Reel
U74HC164L-P14-R	U74HC164G-P14-R	TSSOP-14	Tape Reel

<p>U74HC164G-D14-T</p> <p>(1)Packing Type (2)Package Type (3)Green Package</p>	<p>(1) R: Tape Reel, T: Tube (2) D14: DIP-14, S14: SOP-14, P14: TSSOP-14 (3) G: Halogen Free and Lead Free, L: Lead Free</p>
--	--

#### MARKING

DIP-14	SOP-14 / TSSOP-14
<p>Date Code L: Lead Free G: Halogen Free Lot Code</p>	<p>Date Code L: Lead Free G: Halogen Free Lot Code</p>

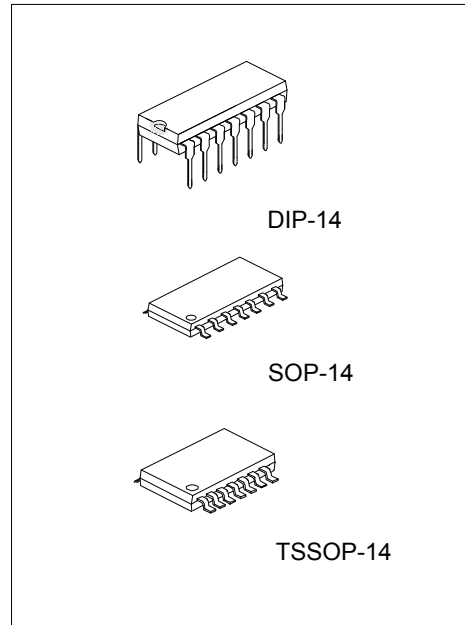

■ PIN CONFIGURATION

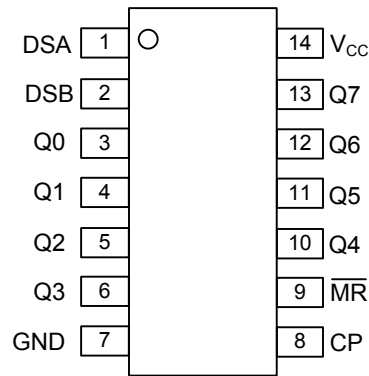

■ FUNCTION TABLE

INPUT				OUTPUT	
$\overline{MR}$	CP	DSA	DSB	Q0	Q1 to Q7
L	X	X	X	L	L to L
H	L	X	X	Q0	Q1 to Q7
H	↑	H	L	L	Q0 to Q6
H	↑	H	H	H	Q0 to Q6
H	↑	L	H	L	Q0 to Q6
H	↑	L	L	L	Q0 to Q6

■ FUNCTIONAL DIAGRAM

Logic Diagram

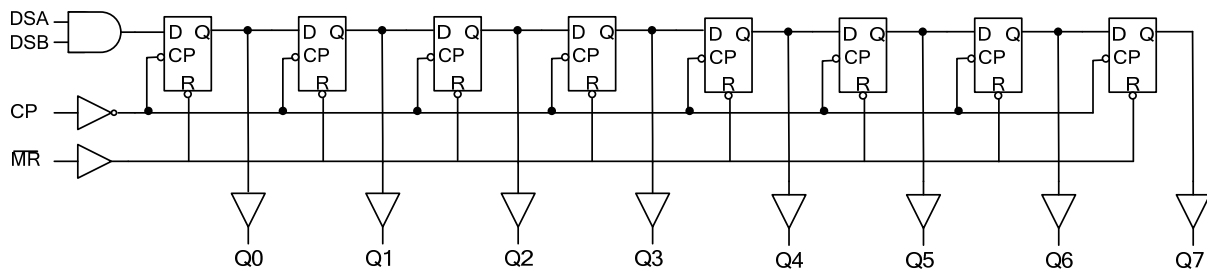

IEC Logic Symbol

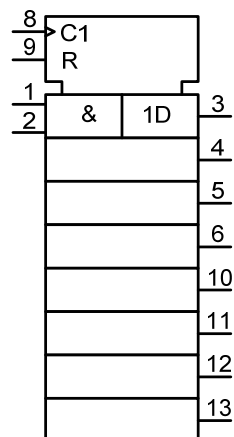

### ■ ABSOLUTE MAXIMUM RATING

PARAMETER	SYMBOL	RATINGS	UNIT	
Supply Voltage	$V_{CC}$	-0.5~ +7	V	
$V_{CC}$ or GND Current	$I_{CC}$	±50	mA	
Output Current	$I_{OUT}$	±25	mA	
Input Diode Current	$I_{IK}$	±20	mA	
Switch Diode Current	$I_{OK}$	±20	mA	
Power Dissipation	DIP-14	$P_D$	750	mW
	SOP-14		500	mW
	TSSOP-14		500	mW
Storage Temperature	$T_{STG}$	-65 ~ +150	°C	

Note: Absolute maximum ratings are those values beyond which the device could be permanently damaged. Absolute maximum ratings are stress ratings only and functional device operation is not implied.

### ■ RECOMMENDED OPERATING CONDITIONS

PARAMETER	SYMBOL	CONDITIONS	MIN	TYP	MAX	UNIT
Supply Voltage	$V_{CC}$		2.0	5.0	6.0	V
Input Voltage	$V_{IN}$		0		$V_{CC}$	V
Output Voltage	$V_{OUT}$		0		$V_{CC}$	V
Input Transition Rise or Fall Rate	$\Delta t/\Delta v$	$V_{CC}=2V$			1000	ns
		$V_{CC}=4.5V$		6.0	500	ns
		$V_{CC}=6V$			400	ns
Operating Temperature	$T_A$		-40		125	°C

### ■ ELECTRICAL CHARACTERISTICS ( $T_A=25^\circ\text{C}$ , unless otherwise specified)

PARAMETER	SYMBOL	TEST CONDITIONS	MIN	TYP	MAX	UNIT
Input Voltage High-Level	$V_{IH}$	$V_{CC}=2.0V$	1.5	1.2		V
		$V_{CC}=4.5V$	3.15	2.4		V
		$V_{CC}=6.0V$	4.2	3.2		V
Input Voltage Low-Level	$V_{IL}$	$V_{CC}=2.0V$		0.8	0.5	V
		$V_{CC}=4.5V$		2.1	1.35	V
		$V_{CC}=6.0V$		2.8	1.8	V
Output Voltage High-Level	$V_{OH}$	$V_{CC}=2.0V, I_{OH}=20\mu A$	1.9	2.0		V
		$V_{CC}=4.5V, I_{OH}=20\mu A$	4.4	4.5		V
		$V_{CC}=6.0V, I_{OH}=20\mu A$	5.9	6.0		V
		$V_{CC}=4.5V, I_{OH}=4mA$	3.98	4.32		V
		$V_{CC}=6.0V, I_{OH}=5.2mA$	5.48	5.81		V
Output Voltage Low-Level	$V_{OL}$	$V_{CC}=2.0V, I_{OL}=20\mu A$		0	0.1	V
		$V_{CC}=4.5V, I_{OL}=20\mu A$		0	0.1	V
		$V_{CC}=6.0V, I_{OL}=20\mu A$		0	0.1	V
		$V_{CC}=4.5V, I_{OL}=4mA$		0.15	0.26	V
		$V_{CC}=6.0V, I_{OL}=5.2mA$		0.16	0.26	V
Input Leakage Current	$I_{(LEAK)}$	$V_{IN}=V_{CC}$ or GND, $V_{CC}=6.0V$			±0.1	μA
Quiescent Supply Current	$I_Q$	$V_{IN}=V_{CC}$ or GND, $V_{CC}=6.0V, I_{OUT}=0$			8	μA
Input Capacitance	$C_{IN}$			3.5		pF

## ■ DYNAMIC CHARACTERISTICS

( $T_A=25^\circ\text{C}$ ,  $\text{GND}=0\text{V}$ ;  $t_R=t_F=6\text{ns}$ ;  $C_L=50\text{pF}$ , unless otherwise specified)

PARAMETER	SYMBOL	TEST CONDITIONS	MIN	TYP	MAX	UNIT
Propagation Delay From CP to Qn	$t_{\text{PHL}}, t_{\text{PLH}}$	$V_{\text{CC}}=2.0\text{V}$		41	170	ns
		$V_{\text{CC}}=4.5\text{V}$		15	34	ns
		$V_{\text{CC}}=6.0\text{V}$		12	29	ns
Propagation Delay From $\overline{\text{MR}}$ to Qn	$t_{\text{PHL}}$	$V_{\text{CC}}=2.0\text{V}$		39	140	ns
		$V_{\text{CC}}=4.5\text{V}$		14	28	ns
		$V_{\text{CC}}=6.0\text{V}$		11	24	ns
Output Transition Time	$t_{\text{THL}}, t_{\text{TLH}}$	$V_{\text{CC}}=2.0\text{V}$		19	75	ns
		$V_{\text{CC}}=4.5\text{V}$		7	15	ns
		$V_{\text{CC}}=6.0\text{V}$		6	13	ns
Clock Pulse Width High or Low	$t_w$	$V_{\text{CC}}=2.0\text{V}$	80	14		ns
		$V_{\text{CC}}=4.5\text{V}$	16	5		ns
		$V_{\text{CC}}=6.0\text{V}$	14	4		ns
Master Reset Pulse Width Low	$t_w$	$V_{\text{CC}}=2.0\text{V}$	60	17		ns
		$V_{\text{CC}}=4.5\text{V}$	12	6		ns
		$V_{\text{CC}}=6.0\text{V}$	10	5		ns
Removal Time $\overline{\text{MR}}$ to CP	$t_{\text{rem}}$	$V_{\text{CC}}=2.0\text{V}$	60	17		ns
		$V_{\text{CC}}=4.5\text{V}$	12	6		ns
		$V_{\text{CC}}=6.0\text{V}$	10	5		ns
Setup Time DSA and DSB to CP	$t_{\text{SU}}$	$V_{\text{CC}}=2.0\text{V}$	60	8		ns
		$V_{\text{CC}}=4.5\text{V}$	12	3		ns
		$V_{\text{CC}}=6.0\text{V}$	10	2		ns
Hold Time DSA and DSB to CP	$t_{\text{H}}$	$V_{\text{CC}}=2.0\text{V}$	+4	-6		ns
		$V_{\text{CC}}=4.5\text{V}$	+4	-2		ns
		$V_{\text{CC}}=6.0\text{V}$	+4	-2		ns
Maximum clock pulse frequency	$f_{\text{MAX}}$	$V_{\text{CC}}=2.0\text{V}$	6	23		MHz
		$V_{\text{CC}}=4.5\text{V}$	30	71		MHz
		$V_{\text{CC}}=6.0\text{V}$	35	85		MHz
Clock Frequency	$f_{\text{CLOCK}}$	$V_{\text{CC}}=2.0\text{V}$			6	MHz
		$V_{\text{CC}}=4.5\text{V}$			31	MHz
		$V_{\text{CC}}=6.0\text{V}$			36	MHz

## ■ OPERATING CHARACTERISTICS ( $T_A=25^\circ\text{C}$ , unless otherwise specified)

PARAMETER	SYMBOL	TEST CONDITIONS	MIN	TYP	MAX	UNIT
Power Dissipation Capacitance	$C_{\text{PD}}$	No load		40		pF

## ■ TEST CIRCUIT AND WAVEFORMS

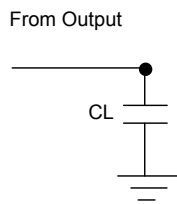

TEST CIRCUIT

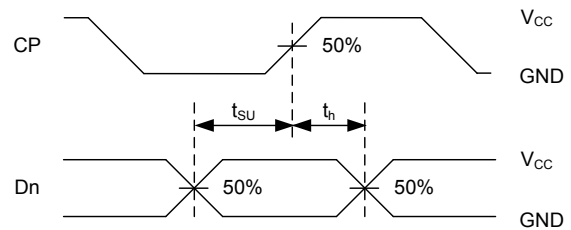

SETUP TIME AND HOLD TIME

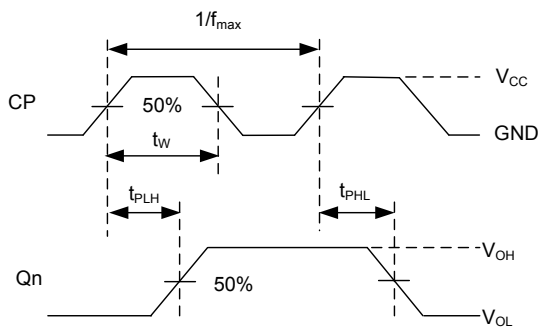

PROPAGATION DELAY TIMES FROM CP TO Qn

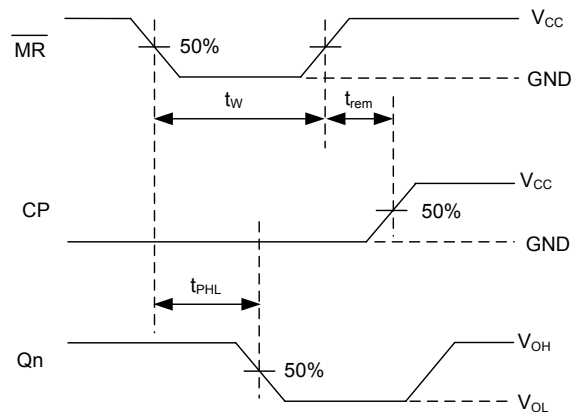

PROPAGATION DELAY TIMES FROM  $\overline{MR}$  TO Qn

UTC assumes no responsibility for equipment failures that result from using products at values that exceed, even momentarily, rated values (such as maximum ratings, operating condition ranges, or other parameters) listed in products specifications of any and all UTC products described or contained herein. UTC products are not designed for use in life support appliances, devices or systems where malfunction of these products can be reasonably expected to result in personal injury. Reproduction in whole or in part is prohibited without the prior written consent of the copyright owner. UTC reserves the right to make changes to information published in this document, including without limitation specifications and product descriptions, at any time and without notice. This document supersedes and replaces all information supplied prior to the publication hereof.

## X-ON Electronics

Largest Supplier of Electrical and Electronic Components

*Click to view similar products for [Counter Shift Registers](#) category:*

*Click to view products by [Unisonic](#) manufacturer:*

Other Similar products are found below :

[5962-8956101EA](#) [MC10E446FNG](#) [74HC195N](#) [74HC4516N](#) [74HCT182N](#) [HEF4021BD](#) [HEF4534BP](#) [MC144111P](#) [NLV74HC165ADTR2G](#)  
[5962-9172201M2A](#) [MC74HC597ADG](#) [MC100EP142MNG](#) [MC100EP016AMNG](#) [5962-9172201MFA](#) [MC74HC164BDR2G](#)  
[TC74HC165AP\(F\)](#) [74AHC164T14-13](#) [MC74LV594ADR2G](#) [NLV14094BDTR2G](#) [NLV74HC595ADTG](#) [MC74HC165AMNTWG](#)  
[TPIC6C595PWG4](#) [74VHC164MTCX](#) [CD74HC195M96](#) [CD4073BM96](#) [CD4053BM96](#) [MM74HC595MTCX](#) [74HCT164T14-13](#)  
[74HCT164S14-13](#) [74HC4094D-Q100J](#) [NLV14014BFELG](#) [NLV74HC165ADR2G](#) [NLV74HC589ADTR2G](#) [NPIC6C595D-Q100,11](#)  
[NPIC6C595PW,118](#) [NPIC6C596ADJ](#) [NPIC6C596APW-Q100J](#) [NPIC6C596D-Q100,11](#) [BU4094BCF-E2](#) [BU4094BCFV-E2](#) [74HC164D14](#)  
[74HC164T14-13](#) [TPIC6C596PWRG4](#) [STPIC6D595MTR](#) [STP08CP05MTR](#) [CD74HC123E](#) [74HC164D.653](#) [74HC165D.653](#)  
[74HCT165D.652](#) [74HCT164D.652](#)