

## N-channel Enhanced mode TO-220/TO-251/TO-251N/TO-252/TO-220F/TO-220SF / TO-262N/DFN5\*6 MOSFET

### Features

- High ruggedness
- Low  $R_{DS(ON)}$  (Typ 1.1 $\Omega$ ) @ $V_{GS}=10V$
- Low Gate Charge (Typ 30nC)
- Improved dv/dt Capability
- 100% Avalanche Tested
- Application: Charge, LED, PC Power

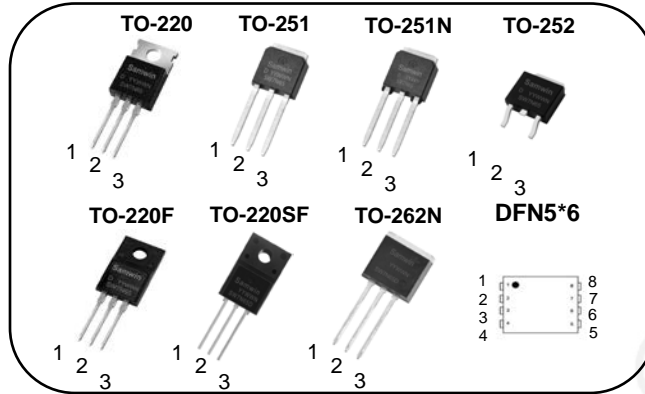

TO-220(F/SF)&TO-251(N)&TO-252&TO-262N : 1. Gate 2. Drain 3. Source  
DFN5\*6 : 4. Gate 5,6,7,8. Drain 1,2,3,4. Source

$BV_{DSS}$  : 650V  
 $I_D$  : 7A  
 $R_{DS(ON)}$  : 1.1 $\Omega$

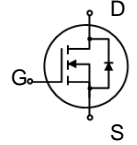

### General Description

This power MOSFET is produced with advanced technology of SAMWIN. This technology enable the power MOSFET to have better characteristics, including fast switching time, low on resistance, low gate charge and especially excellent avalanche characteristics.

### Order Codes

Item	Sales Type	Marking	Package	Packaging
1	SW P 7N65D	SW7N65D	TO-220	TUBE
2	SW I 7N65D	SW7N65D	TO-251	TUBE
3	SW N 7N65D	SW7N65D	TO-251N	TUBE
4	SW D 7N65D	SW7N65D	TO-252	REEL
5	SW F 7N65D	SW7N65D	TO-220F	TUBE
6	SW MN 7N65D	SW7N65D	TO-220SF	TUBE
7	SW J 7N65D	SW7N65D	TO-262N	TUBE
8	SW HA 7N65D	SW7N65D	DFN5*6	REEL

### Absolute maximum ratings

Symbol	Parameter	Value					Unit
		TO-220	TO-251/TO-251N	TO-252	TO-220F/TO-220SF	TO-262N	
$V_{DSS}$	Drain to source voltage	650					V
$I_D$	Continuous drain current (@ $T_C=25^\circ C$ )	7*					A
	Continuous drain current (@ $T_C=100^\circ C$ )	4.4*					A
$I_{DM}$	Drain current pulsed (note 1)	28					A
$V_{GS}$	Gate to source voltage	$\pm 30$					V
$E_{AS}$	Single pulsed avalanche energy (note 2)	430					mJ
$E_{AR}$	Repetitive avalanche energy (note 1)	40					mJ
dv/dt	Peak diode recovery dv/dt (note 3)	5					V/ns
$P_D$	Total power dissipation (@ $T_C=25^\circ C$ )	208.3	173.6	27.8	186.6		W
	Total power dissipation (@ $T_a=25^\circ C$ )					2.4	W
	Derating factor above 25 $^\circ C$	1.67	1.39	0.22	1.5	0.02	W/ $^\circ C$
$T_{STG}, T_J$	Operating junction temperature & storage temperature	-55 ~ + 150					$^\circ C$
$T_L$	Maximum lead temperature for soldering purpose, 1/8 from case for 5 seconds.	300					$^\circ C$

\*. Drain current is limited by junction temperature.

## Thermal characteristics

Symbol	Parameter	Value						Unit
		TO-220	TO-251/TO-251N	TO-252	TO-220F/TO-220SF	TO-262N	DFN5*6	
$R_{thjc}$	Thermal resistance, Junction to case	0.6	0.72		4.5	0.67		°C/W
$R_{thja}$	Thermal resistance, Junction to ambient	60	82		50	61	51.4	°C/W

Note:  $R_{thja}$  is the sum of the junction-to-case and case-to-ambient thermal resistance where the case thermal reference is defined as the solder mounting surface of the drain pins.  $R_{thjc}$  is guaranteed by design while  $R_{thca}$  is determined by the user's board design.



DFN5\*6  $R_{thja}$  : 51.4°C/W on a 1 in<sup>2</sup> pad of 2oz copper.

## Electrical characteristic ( $T_C = 25^\circ\text{C}$ unless otherwise specified )

Symbol	Parameter	Test conditions	Min.	Typ.	Max.	Unit
<b>Off characteristics</b>						
$BV_{DSS}$	Drain to source breakdown voltage	$V_{GS}=0V, I_D=250\mu A$	650			V
$\Delta BV_{DSS} / \Delta T_J$	Breakdown voltage temperature coefficient	$I_D=250\mu A$ , referenced to $25^\circ\text{C}$		0.51		V/°C
$I_{DSS}$	Drain to source leakage current	$V_{DS}=650V, V_{GS}=0V$			1	$\mu A$
		$V_{DS}=520V, T_C=125^\circ\text{C}$			50	$\mu A$
$I_{GSS}$	Gate to source leakage current, forward	$V_{GS}=30V, V_{DS}=0V$			100	nA
	Gate to source leakage current, reverse	$V_{GS}=-30V, V_{DS}=0V$			-100	nA
<b>On characteristics</b>						
$V_{GS(TH)}$	Gate threshold voltage	$V_{DS}=V_{GS}, I_D=250\mu A$	2.5		4.5	V
$R_{DS(ON)}$	Drain to source on state resistance	$V_{GS}=10V, I_D = 3.5A, T_C=25^\circ\text{C}$		1.1	1.4	$\Omega$
		$V_{GS}=10V, I_D = 3.5A, T_C=125^\circ\text{C}$		2.4		$\Omega$
$G_{fs}$	Forward transconductance	$V_{DS}=30V, I_D=3.5A$		6.3		S
<b>Dynamic characteristics</b>						
$C_{iss}$	Input capacitance	$V_{GS}=0V, V_{DS}=25V, f=1\text{MHz}$		1230		pF
$C_{oss}$	Output capacitance			108		
$C_{riss}$	Reverse transfer capacitance			16		
$t_{d(on)}$	Turn on delay time	$V_{DS}=350V, I_D=7A, R_G=25\Omega$ (note 4,5)		16		ns
$t_r$	Rising time			36		
$t_{d(off)}$	Turn off delay time			83		
$t_f$	Fall time			40		
$Q_g$	Total gate charge	$V_{DS}=520V, V_{GS}=10V, I_D=7A$ (note 4,5)		30		nC
$Q_{gs}$	Gate-source charge			5		
$Q_{gd}$	Gate-drain charge			15		
$R_g$	Gate resistance	$V_{DS}=0V$ , Scan F mode		1.7		$\Omega$

## Source to drain diode ratings characteristics

Symbol	Parameter	Test conditions	Min.	Typ.	Max.	Unit
$I_S$	Continuous source current	Integral reverse p-n Junction diode in the MOSFET			7	A
$I_{SM}$	Pulsed source current				28	A
$V_{SD}$	Diode forward voltage drop.	$I_S=7A, V_{GS}=0V$			1.4	V
$t_{rr}$	Reverse recovery time	$I_S=7A, V_{GS}=0V$ ,		436		ns
$Q_{rr}$	Reverse recovery charge	$di_F/dt=100A/\mu s$		8.7		$\mu C$

### ※. Notes

1. Repeitative rating : pulse width limited by junction temperature.
2.  $L = 17.5\text{mH}, I_{AS} = 7A, V_{DD} = 50V, R_G=25\Omega$ , Starting  $T_J = 25^\circ\text{C}$
3.  $I_{SD} \leq 7A, di/dt = 100A/\mu s, V_{DD} \leq BV_{DSS}$ , Starting  $T_J = 25^\circ\text{C}$
4. Pulse Test : Pulse Width  $\leq 300\mu s$ , duty cycle  $\leq 2\%$ .
5. Essentially independent of operating temperature.

**Fig. 1. On-state characteristics**

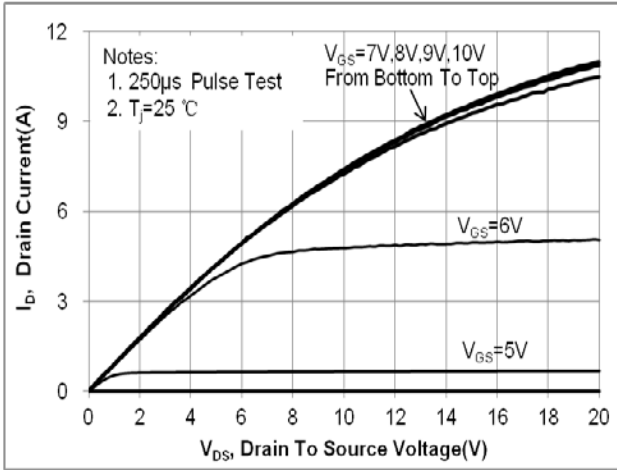

**Fig. 2. Transfer Characteristics**

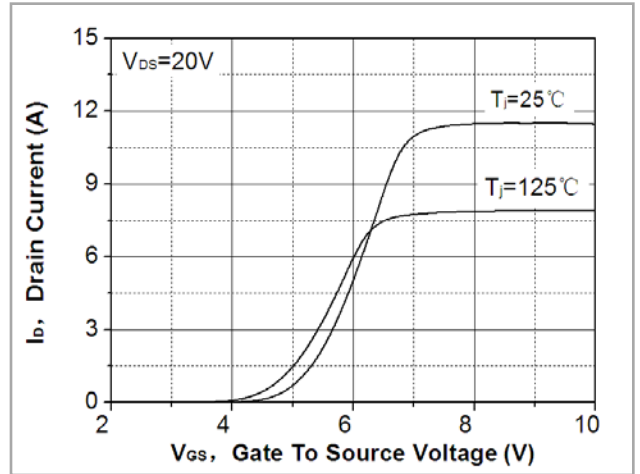

**Fig. 3. On-resistance variation vs. drain current and gate voltage**

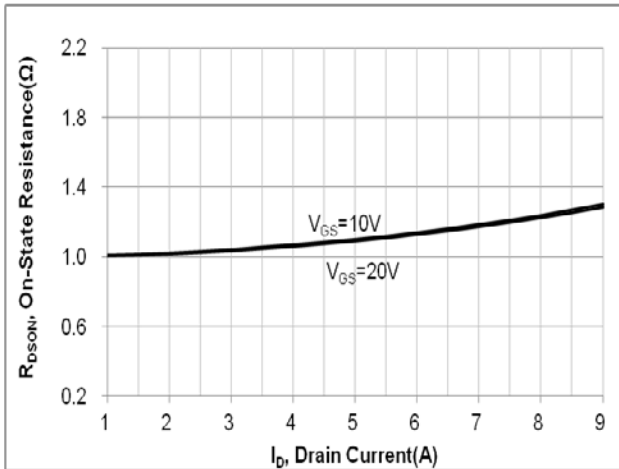

**Fig. 4. On-state current vs. diode forward voltage**

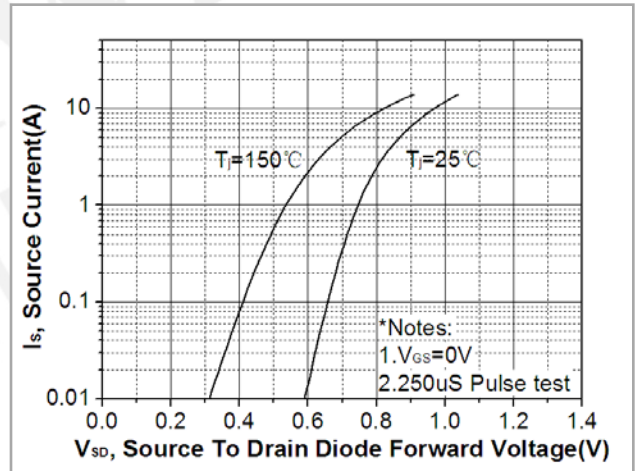

**Fig 5. Breakdown Voltage Variation vs. Junction Temperature**

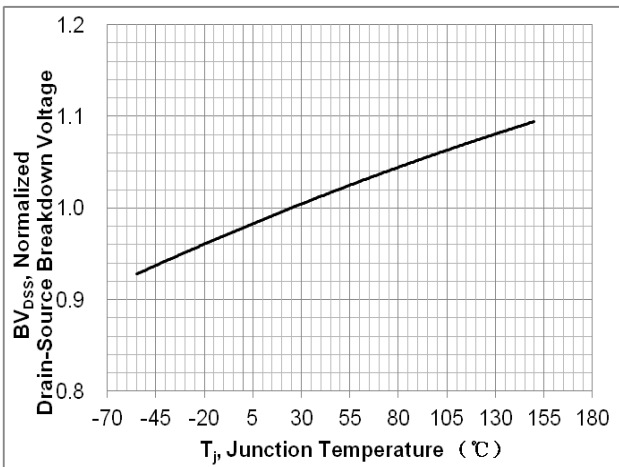

**Fig. 6. On resistance variation vs. junction temperature**

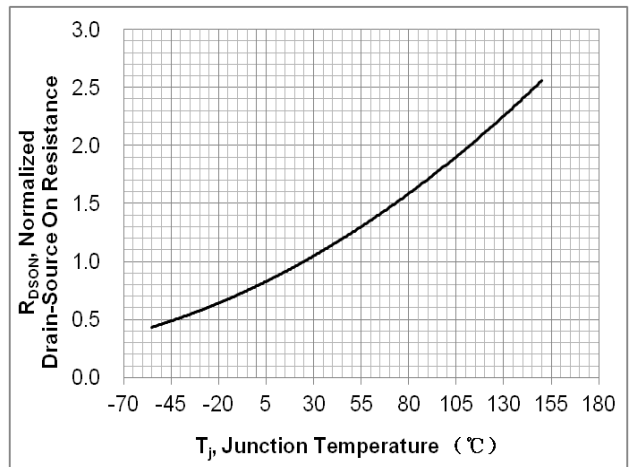

Fig. 7. Gate charge characteristics

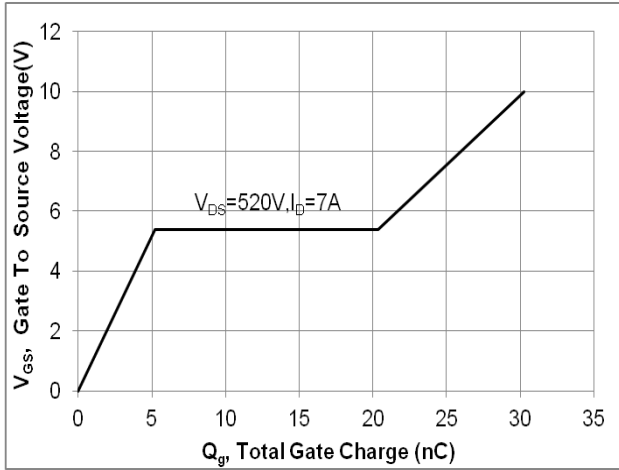

Fig. 8. Capacitance Characteristics

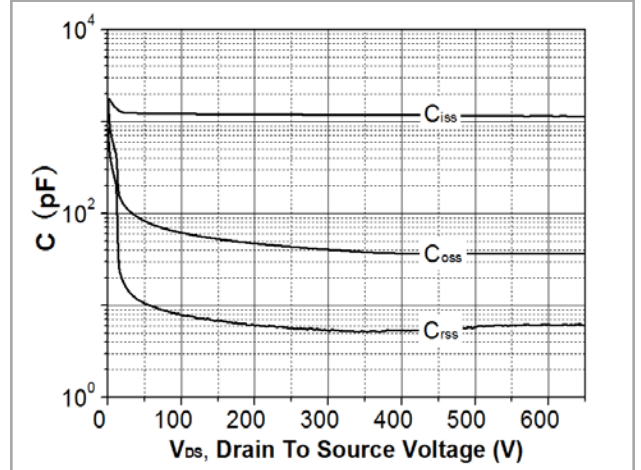

Fig. 9. Maximum safe operating area(TO-220)

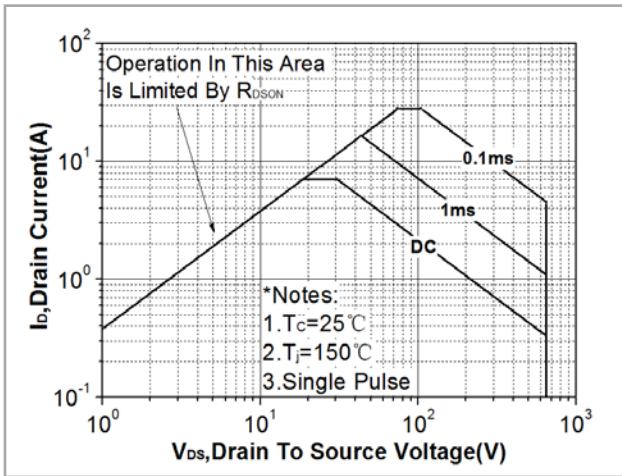

Fig. 10. Maximum safe operating area (TO-251/TO-251N/TO-252)

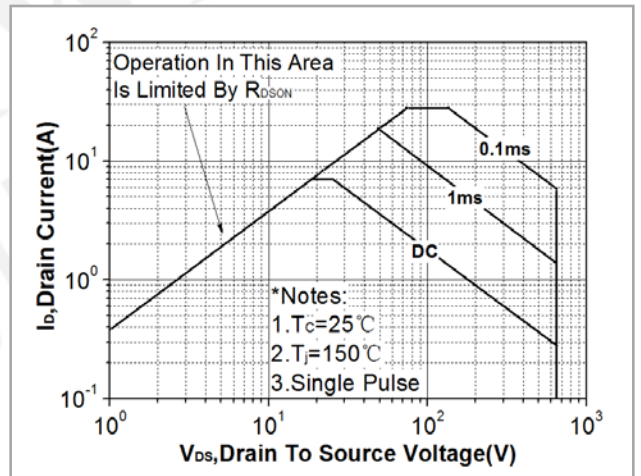

Fig. 11. Maximum safe operating area (TO-220F/TO-220SF)

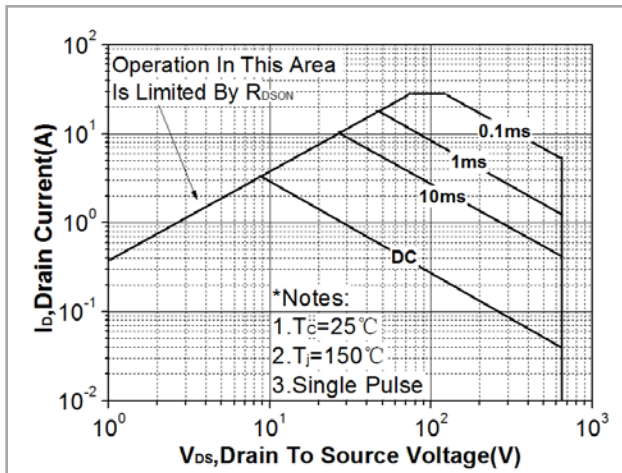

Fig. 12. Maximum safe operating area(TO-262N)

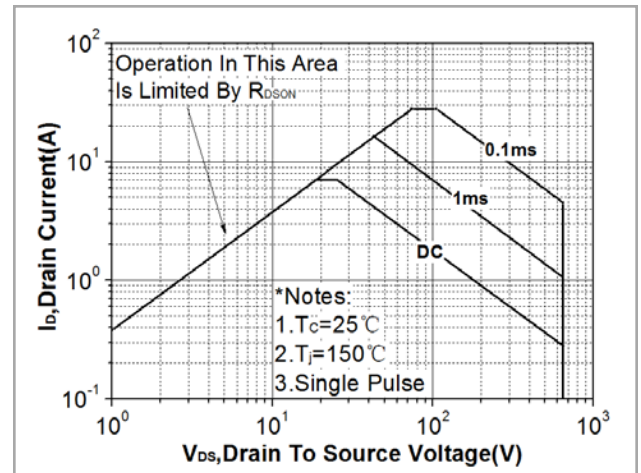

Fig. 13. Maximum safe operating area(DFN5\*6)

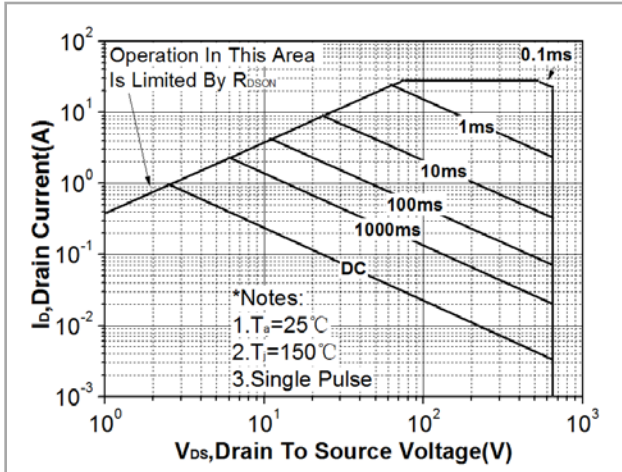

Fig. 14. Transient thermal response curve(TO-220)

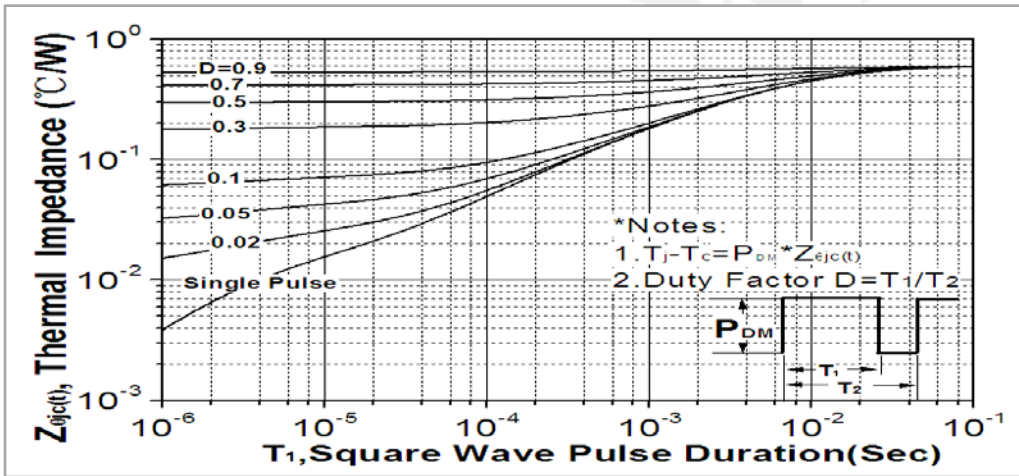

Fig. 15. Transient thermal response curve (TO-251/TO-251N/TO-252)

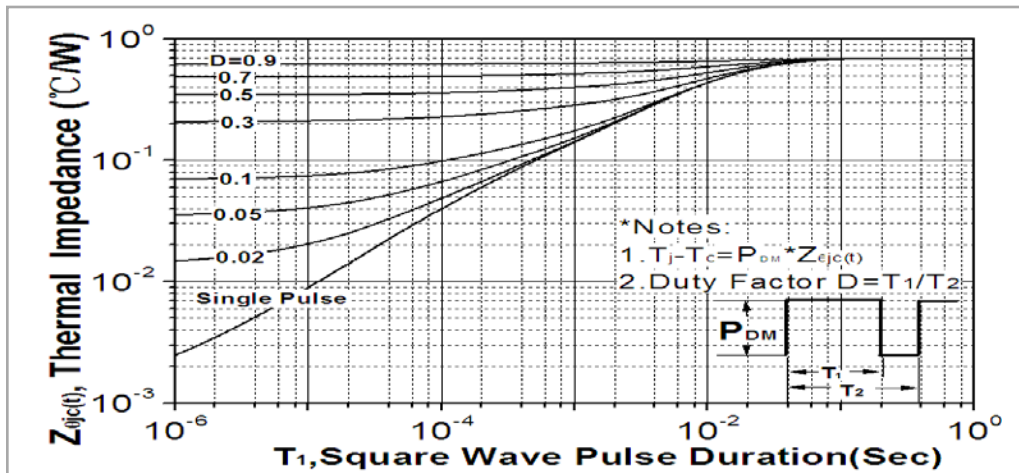



Fig. 16. Transient thermal response curve(TO-220F/TO-220SF)

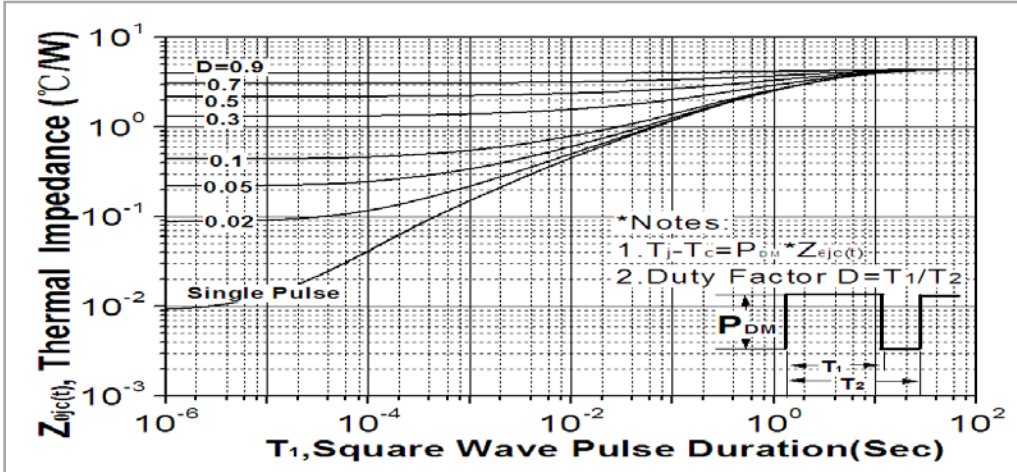

Fig. 17. Transient thermal response curve(TO-262N)

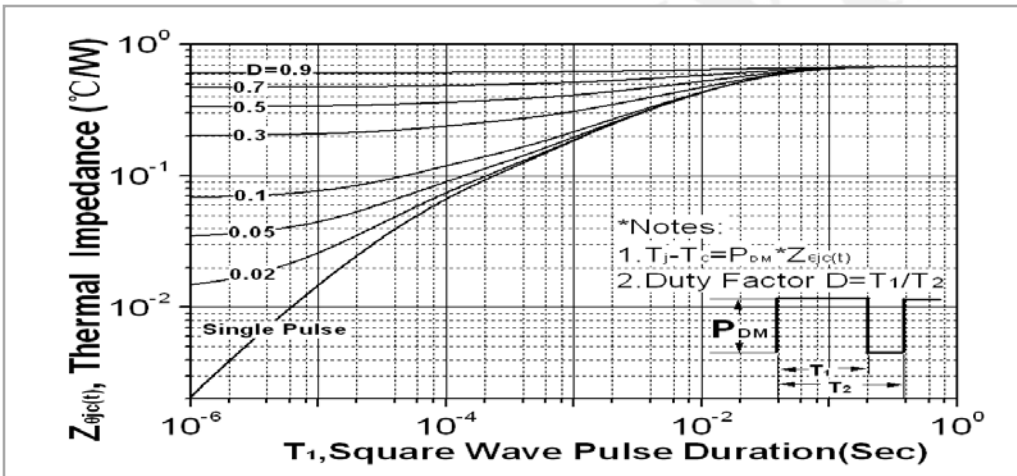
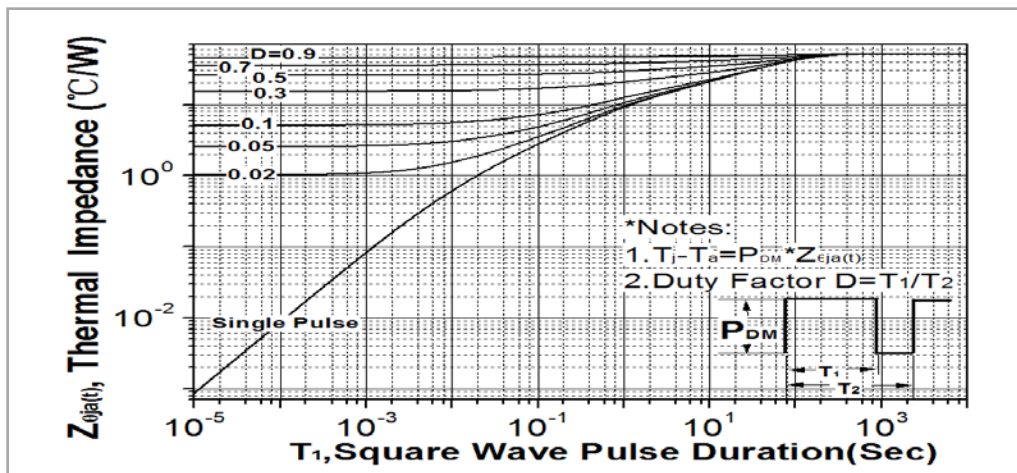
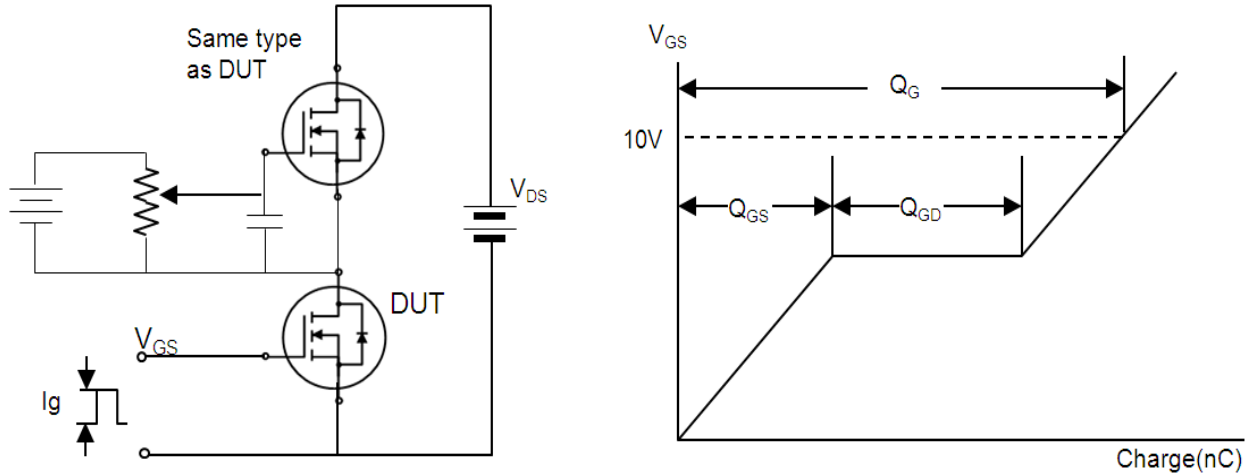

Fig. 18. Transient thermal response curve(DFN5\*6)



**Fig. 19. Gate charge test circuit & waveform**



**Fig. 20. Switching time test circuit & waveform**

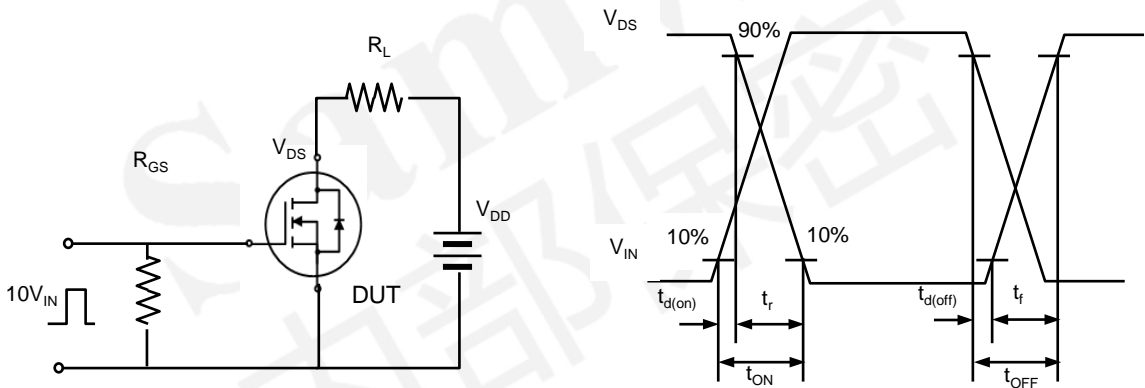

**Fig. 21. Unclamped Inductive switching test circuit & waveform**

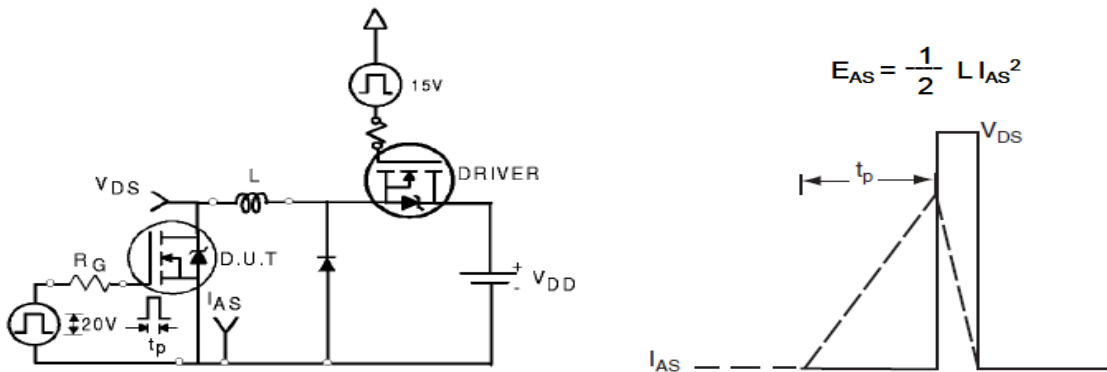
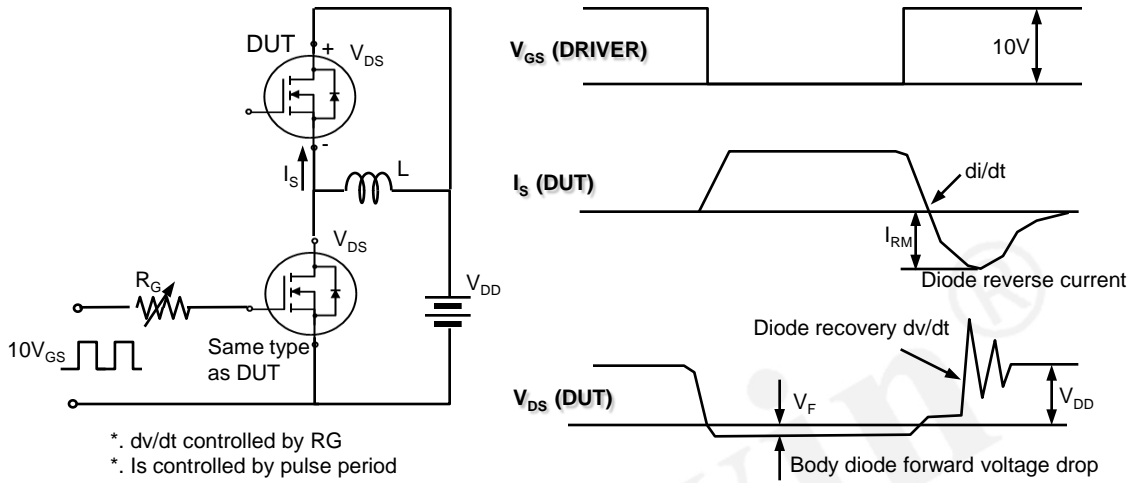

Fig. 22. Peak diode recovery dv/dt test circuit & waveform



## DISCLAIMER

- \* All the data & curve in this document was tested in XI'AN SEMIPOWER TESTING & APPLICATION CENTER.
- \* This product has passed the PCT,TC,HTRB,HTGB,HAST,PC and Solderdunk reliability testing.
- \* Qualification standards can also be found on the Web site (<http://www.semipower.com.cn>)
- \* Suggestions for improvement are appreciated, Please send your suggestions to [samwin@samsemi.com](mailto:samwin@samsemi.com)



## X-ON Electronics

Largest Supplier of Electrical and Electronic Components

*Click to view similar products for [MOSFET](#) category:*

*Click to view products by [Sam&wing](#) manufacturer:*

Other Similar products are found below :

[614233C](#) [648584F](#) [MCH3443-TL-E](#) [MCH6422-TL-E](#) [FDPF9N50NZ](#) [FW216A-TL-2W](#) [FW231A-TL-E](#) [APT5010JVR](#) [NTNS3A92PZT5G](#)  
[IRF100S201](#) [JANTX2N5237](#) [2SK2464-TL-E](#) [2SK3818-DL-E](#) [FCA20N60\\_F109](#) [FDZ595PZ](#) [STD6600NT4G](#) [FSS804-TL-E](#) [2SJ277-DL-E](#)  
[2SK1691-DL-E](#) [2SK2545\(Q,T\)](#) [D2294UK](#) [405094E](#) [423220D](#) [MCH6646-TL-E](#) [TPCC8103,L1Q\(CM](#) [367-8430-0972-503](#) [VN1206L](#)  
[424134F](#) [026935X](#) [051075F](#) [SBVS138LT1G](#) [614234A](#) [715780A](#) [NTNS3166NZT5G](#) [751625C](#) [873612G](#) [IRF7380TRHR](#)  
[IPS70R2K0CEAKMA1](#) [RJK60S3DPP-E0#T2](#) [RJK60S5DPK-M0#T0](#) [APT5010JVFR](#) [APT12031JFLL](#) [APT12040JVR](#) [DMN3404LQ-7](#)  
[NTE6400](#) [JANTX2N6796U](#) [JANTX2N6784U](#) [JANTXV2N5416U4](#) [SQM110N05-06L-GE3](#) [SIHF35N60E-GE3](#)