

描述/Description

- XNS21767基于Trench FS-IGBT技术, 提供紧凑且高性能的变频伺服解决方案, 适合较高功率的消费和工业应用领域。
XNS21767 is an Advanced IPM Based on Trench FS-IGBT Technology as a Compact and High Performance Inverter or Server Solution for Higher Power Consumption and Industrial Applications.
- XNS21767通过优化开关速度和减小寄生电感实现低电磁干扰(EMI)特性。
XNS21767 Features Low Electromagnetic Interference (EMI) Characteristics Through Optimizing Switching Speed and Reducing Parasitic Inductance.
- XNS21767内置优化的保护和驱动电路并与低损耗IGBT匹配, 欠压锁定和短路保护进一步提高了系统可靠性。
XNS21767 Combines Optimized Circuit Protection and Drive Matched to Low-Loss IGBTs. System Reliability is Further Enhanced by the Integrated Under-Voltage Lock-Out and Short-Circuit Protection.
- XNS21767内置高速HVIC, 提供无光耦单电源IGBT栅极驱动能力, 进一步减小了逆变器系统设计的总体尺寸。
XNS21767 Combines High Speed HVIC Provides Opto-Coupler-Less Single-Supply IGBT Gate Driving Capability that Further Reduce the Overall Size of the Inverter System Design.
- 分开的负直流端子使得变频器的每相电流可以单独监视到。
Each Phase Current of Inverter can be Monitored Separately Due to the Divided Negative DC Terminals.

主要特点

- 600V-30 A三相IGBT逆变器, 包含栅极驱动和保护的控制IC
- 低损耗、短路额定的IGBT
- 采用DBC (Al2O3) 基板实现非常低的热阻
- 内置自举二极管和专用的Vs 引脚以简化印刷电路板布局
- 低端IGBT的独立发射极开路引脚用于三相电流感测
- 绝缘级别2500V_{rms}/1min
- 单接地电源供电

Features

- 600V-30A 3-Phase IGBT Inverter Bridge Including Control ICs for Gate Driving and Protection
- Low-Loss, Short-Circuit Rated IGBTs
- Very Low Thermal Resistance Due to Using Al2O3 DBC
- Built-In Bootstrap Diodes and Dedicated Vs Pins Simplify PCB Layout
- Separate Open-Emitter Pins from Low-Side IGBTs for Three-Phase Current Sensing
- Isolation Voltage Rating of 2500 V_{rms} for 1 min.
- Single-Grounded Power Supply Due to Built-In HVIC

应用

- 运动控制 – 家用设备 / 工业电机

Applications

- Motion Control – Home Appliance / Industrial Motor



图1. 封装概览

Figure1. Package Overview

引脚描述 / Pin descriptions

引脚号/Pin Number	引脚名/Pin Name	引脚描述/Pin Description
1	VUFS	High-Side Bias Voltage Ground for U-Phase IGBT Driving 上桥臂U相驱动地端
2	VUFB	High-Side Bias Voltage for U-Phase IGBT Driving 上桥臂U相驱动正端
3	VP1	Common Bias Voltage for IC and IGBTs Driver 控制电源正端
4	UP	Signal Input for High-Side U Phase 上半桥U相逻辑输入端
5	VVFS	High-Side Bias Voltage Ground for V-Phase IGBT Driving 上桥臂V相驱动地端
6	VVFB	High-Side Bias Voltage for V-Phase IGBT Driving 上桥臂V相驱动正端
7	VP1	Common Bias Voltage for IC and IGBTs Driver 控制电源正端
8	VP	Signal Input for High-Side V Phase 上半桥V相逻辑输入端
9	VWFS	High-Side Bias Voltage Ground for W-Phase IGBT Driving 上桥臂W相驱动地端
10	VWFB	High-Side Bias Voltage for W-Phase IGBT Driving 上桥臂W相驱动正端
11	VP1	Common Bias Voltage for IC and IGBTs Driver 控制电源正端
12	WP	Signal Input for High-Side W Phase 上半桥W相逻辑输入端
13	VNO	Common Supply Ground 门极控制参考地端
14	UN	Signal Input for Low-Side U Phase 下桥臂U相逻辑输入端
15	VN	Signal Input for Low-Side V Phase 下桥臂V相逻辑输入端
16	WN	Signal Input for Low-Side W Phase 下桥臂W相逻辑输入端
17	FO	Fault Output 故障信号输出端
18	NC	N.C 空引脚
19	CIN	Capacitor for Short-Circuit Current Detector Input 过流电流跳闸电压检测端
20	VNC	Common Supply Ground 下桥臂参考地端
21	VN1	Common Bias Voltage for IC and IGBTs Driver 控制电源正端
22	NW	Negative DC-Link Input for W-Phase 逆变器直流电源负端（W相）
23	NV	Negative DC-Link Input for V-Phase 逆变器直流电源负端（V相）
24	NU	Negative DC-Link Input for U-Phase 逆变器直流电源负端（U相）
25	W	Output for W-Phase 逆变器W相输出端
26	V	Output for V-Phase 逆变器V相输出端
27	U	Output for U-Phase 逆变器U相输出端
28	P	Positive DC-Link Input 逆变器直流电压正端
29	NC	N.C 空引脚

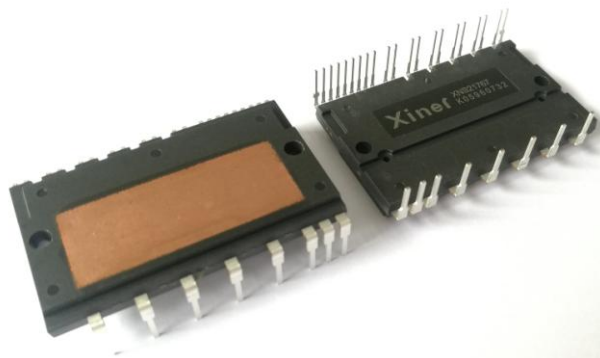
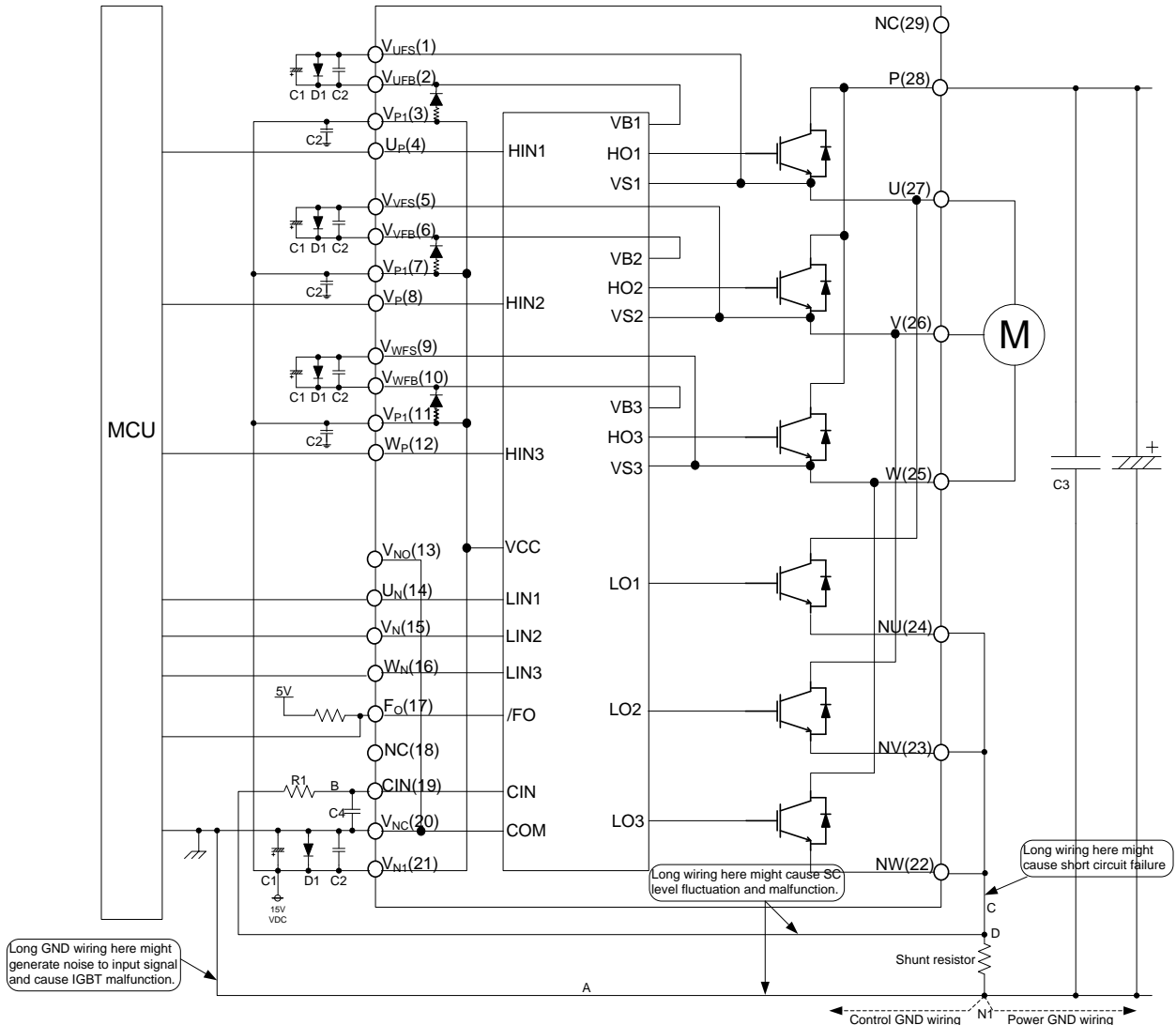

Typical Application Circuit

注/Note:

1. 推荐在电源上加稳压二极管D1 (24V/1W)，防止浪涌电压损坏IPM。
It is recommended to insert a Zener diode D1 (24V/1W) between each pair of control supply terminals to prevent surge destruction.
2. 输入正逻辑，下拉电阻5.4KΩ。为了避免故障，应尽可能缩短每个输入端的连线（小于2-3 cm）。
Input logic is High-active. There is a 5.4KΩ pull down resistor. To avoid malfunction, the wiring of each input should be as short as possible (less than 2-3cm).
3. 为避免保护功能出错，应尽可能缩短R1和C4周围的连线。
To prevent errors of the protection function, the wiring of B, C and D point should be as short as possible.
4. 在短路保护电路中，R1C4的时间常数应在1.5 ~ 2.0 μs 的范围内进行选择。
In the short-circuit protection circuit, please select the R1C4 time constant in the range 1.5 ~ 2.0 μs.
5. 每个电容都应尽可能地靠近产品的引脚安装。(C1: 温度特性好, 频率特性好; C2: 0.22u-2uF, 温度特性好, 频率特性好)
Each capacitor should be mounted as close to the pins of the product as possible. (C1: good temperature, frequency characteristic electrolytic type and C2: 0.22u-2uF, good temperature, frequency and DC bias characteristic ceramic type are recommended.)
6. 为防止浪涌的破坏, 应尽可能缩短滤波电容和P & GND 引脚间的连线。推荐在P & GND 引脚间使用0.1 ~ 0.22 μF 的高频无感电容C3。
To prevent surge destruction, the wiring between the smoothing capacitor and the P & GND pins should be as short as possible. The use of a high-frequency non-inductive C3 capacitor of around 0.1 ~ 0.22 μF between the P & GND pins is recommended.
7. 在各种家用电器设备中, 几乎都用到了继电器。在这些情况下, MCU 和继电器之间应留有足够的距离。
Relays are used at almost every systems of electrical equipments at industrial application. In these cases, there should be sufficient distance between the CPU and the relays.
8. 控制地和功率地应该分开不限, 相交于一点N1。

轮廓封装详图 / Detailed Package Outline Drawings

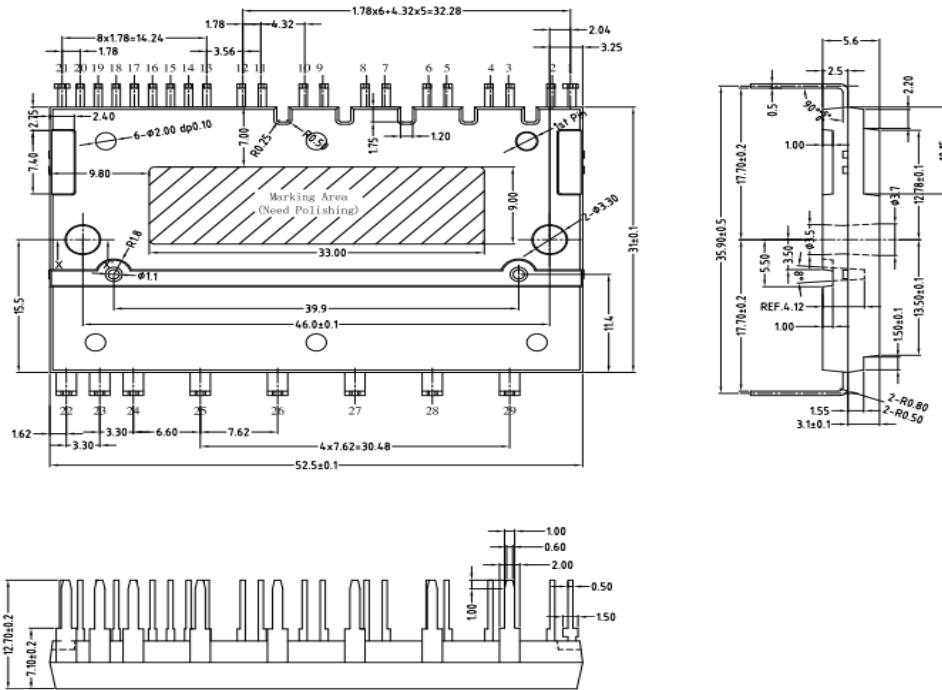

X-ON Electronics

Largest Supplier of Electrical and Electronic Components

Click to view similar products for [Emulators/Simulators](#) category:

Click to view products by [XINER](#) manufacturer:

Other Similar products are found below :

[AC244062](#) [AC244064](#) [SPC563M64CAL144](#) [SPC563M64CAL176](#) [ST7MDT2-EMU2B](#) [IM3316](#) [IM1281B](#) [IM1275](#) [IM1227](#) [IM1259G](#)
[IM1253B](#) [IM1253B\(D\)](#) [MJYS-QKJL-40/380V](#) [MJYS-QKJL-75/380V](#) [MJYD-JL-75/380V](#) [MJYD-JL-40/380V](#) [CI-B02CS01S](#) [CI-B03CS01S](#)
[CI-BO3GS01S](#) [GD10PJX120L2S](#) [HEDS-9730#Q50](#) [HEDS-9700#F50](#) [L-MZ07](#) [L-MZ02](#) [L-MZ021](#) [TXVT4G6M-S](#) [JL_MOD_FH_V1.0](#)
[MKSDSOCKET-Pinboard V1](#) [CY3250-24X33](#) [AC244060](#) [7027-D-350](#) [DS1747WP-120IND+](#) [AC244061](#) [S5U1C31W74T1300](#)
[S5U1C17M13T2100](#) [S5U1C17M13T1100](#) [J-Link ULTRA+](#) [AFM201TI-AY2LED2](#) [AFW121T-EVB](#) [CP2102](#) [CE118M12](#) [ESP32-A1S](#)
[ESP32-CAM](#) [ESP-32S](#) [ADZS-ICE-1000](#) [ADZS-ICE-2000](#) [USB-EA-CONVZ](#) [BH-USB-100v2-ARM](#) [BH-USB-100v2D](#) [BH-USB-200](#)