



36V/5A Over Voltage Protection IC

General Description

The LP5304 is an Over-Voltage-Protection(OVP) device. The device will switch off internal MOSFET to disconnect IN to OUT to protect load when any of input voltage over the threshold. The Over temperature protection (OTP) function monitors chip temperature to protect the device.

The LP5304 is available in DFN-8 package. Standard products are Pb-free and Halogen-free.

Order Information

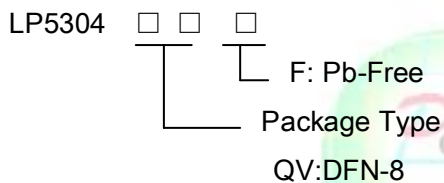

Features

- ◆ Input Voltage Range: 3.5V to 36V
- ◆ Typical Output Power on Time: 9mS
- ◆ OVP Threshold: 6.1V
- ◆ OVP Threshold Time Less Than 1uS
- ◆ Output current:5A
- ◆ Low $R_{(DS(ON))}$ Internal Switches:30mΩ @ 5V
- ◆ Output Discharge
- ◆ Thermal Fault Protection
- ◆ DFN-8 3*3mm Package
- ◆ RoHS Compliant and 100% Lead (Pb)-Free

Applications

- ◇ GPS
- ◇ PMP
- ◇ PAD
- ◇ MID
- ◇ Digital cameras, Digital Videos

Typical Application Circuit

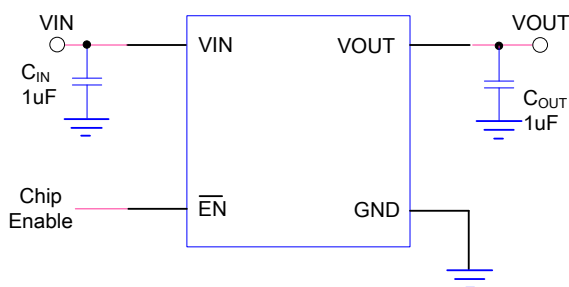

Marking Information

Device	Marking	Package	Shipping
LP5304QVF	LPS LP5304 YWX	DFN-8	5K/REEL
Y: Year code. W: Week code. X: Batch numbers.			



Functional Pin Description

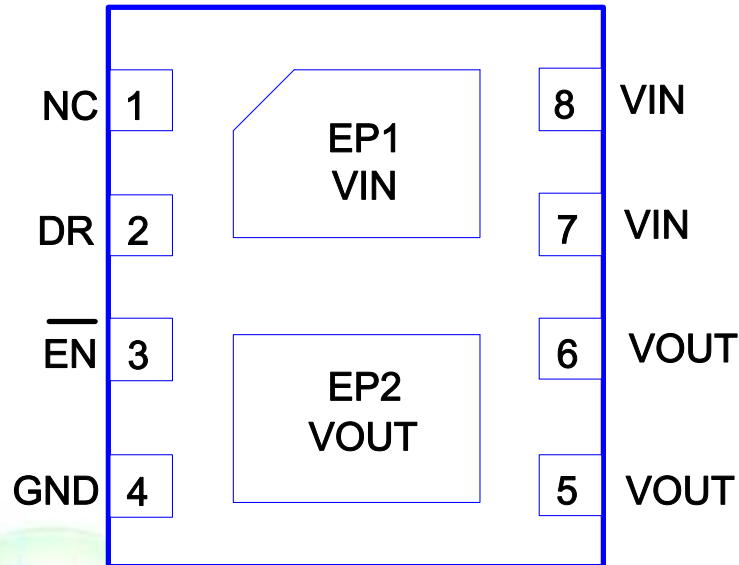

Pin Description

DFN-8	PIN	DESCRIPTION
1	NC	No connector.
2	DR	NMOS gate driver.
3	$\overline{\text{EN}}$	Chip enable pin. Active low.
4	GND	Ground.
5/6/EP2	OUT	Output pin.
7/8/EP1	VIN	Input pin. A 1uF low ESR ceramic capacitor or larger must be connected as close as to this pin. It is recommended to use 50V capacitor or according to application.



Function Block Diagram

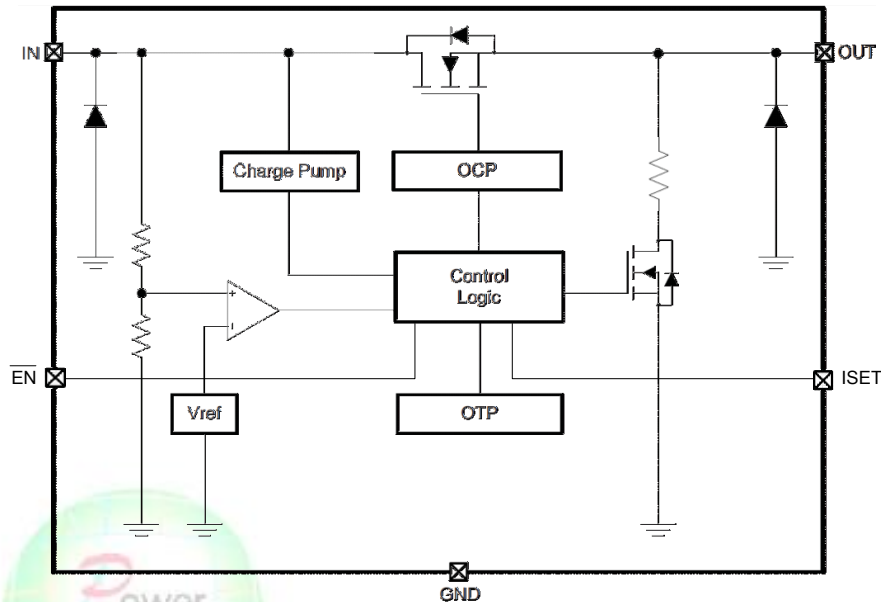

Absolute Maximum Ratings ^{Note 1}

◇ Input to GND	-----	36V
◇ Output Voltage to GND	-----	6.5V
◇ Other Pin to GND	-----	6.5V
◇ Maximum Junction Temperature	-----	150°C
◇ Operating Ambient Temperature Range (Ta)	-----	-40°C to 85°C
◇ Maximum Soldering Temperature (at leads, 10 sec)	-----	260°C

Note 1. Stresses beyond those listed under "Absolute Maximum Ratings" may cause permanent damage to the device. These are stress ratings only, and functional operation of the device at these or any other conditions beyond those indicated in the operational sections of the specifications is not implied. Exposure to absolute maximum rating conditions for extended periods may affect device reliability.

Thermal Information

◇ Maximum Power Dissipation (DFN-8, PD, TA=25°C)	-----	1.5W
◇ Thermal Resistance (DFN-8, JA)	-----	46°C/W

ESD Susceptibility

◇ HBM(Human Body Mode) ^{Note 2}	-----	2KV
◇ MM(Machine Mode) ^{Note 3}	-----	200V

Note 2. The Human body model (HBM) is a 100pF capacitor discharged through a 1.5kΩ resistor into each pin. The testing is done according JEDEC.

Note 3. Machine Model (MM) is a 200pF capacitor discharged through a 500nH inductor with no series resistor into each pin. The testing is done according JEDEC.



Electrical Characteristics

(Typical values are TA=25°C)

Symbol	Parameter	Conditions	LP5304			Unit
			Min.	Typ.	Max.	
DC characteristics and Power-ON-Reset						
V _{IN}	Input Voltage		3.5		36	V
I _Q	Input quiescent current	V _{IN} =5V, EN=LOW, I _{OUT} =0A		110		uA
I _{SD}		V _{IN} =5V, EN=HIGH, I _{OUT} =0A			1	
R _{ON}	IN-to-OUT ON resistance	V _{IN} =5V, I _{OUT} =4A		30		mΩ
R _{DISCHARGE}	Output discharge resistance			4.3		kΩ
V _{EN(L)}	Enable Threshold Low	Chip enable			0.4	V
V _{EN(H)}	Enable Threshold High	Chip shutdown	1.4			V
UVLO	Under voltage lock out threshold	V _{IN} increasing from 0~5V	2.6	2.8	3	V
V _{HYS-UVLO}	Under voltage lock out hysteresis	V _{IN} decreasing from 5~0V		500		mV
T _{ON}	Output power-on time	EN = LOW ,		9		mS
	Turn on through EN	EN = HIGH -> LOW,		9		
Input Over-Voltage-Protection (OVP)						
V _{OVP}	OVP threshold	V _{IN} increasing from 5~7V	5.8	6.1	6.4	V
V _{HYS-OVP}	OVP hysteresis	V _{IN} decreasing from 7~5V		300		mV
T _{OVP}	OVP active time	V _{IN} = 5 -> 10V			1	uS
T _{ON(OVP)}	OVP recovery time	V _{IN} = 10 -> 5V to output ON		9		mS
I _{out}	Output current			5		A
Over-Temperature-Protection (OTP)						
OTP threshold				150		°C
OTP hysteresis				40		°C



Typical Operating Characteristics

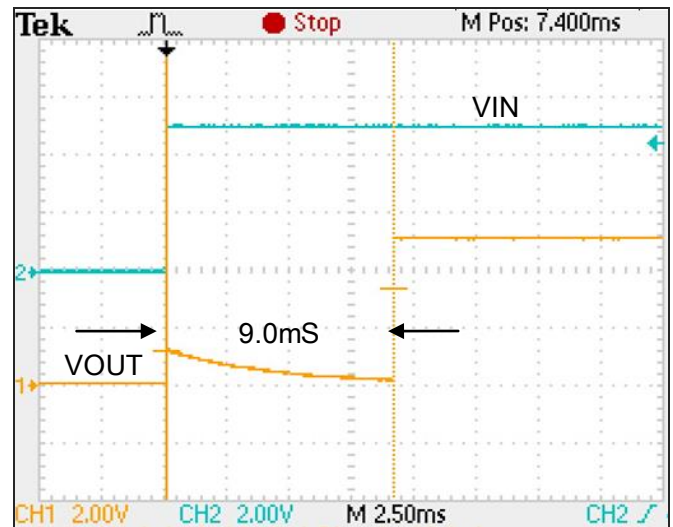
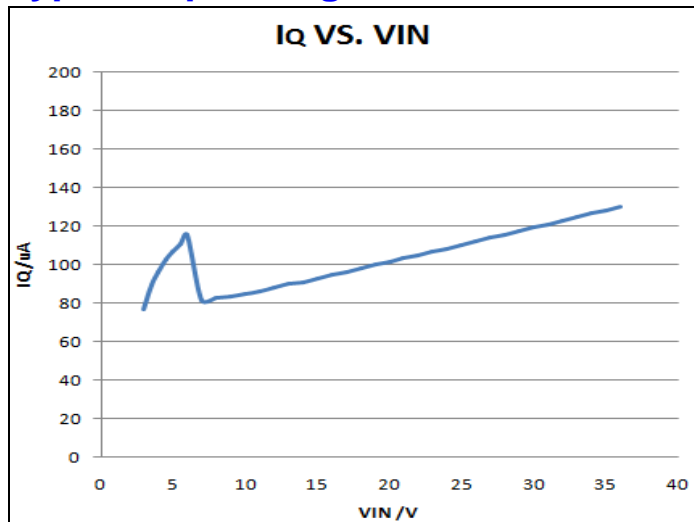

Turn on with EN=0V

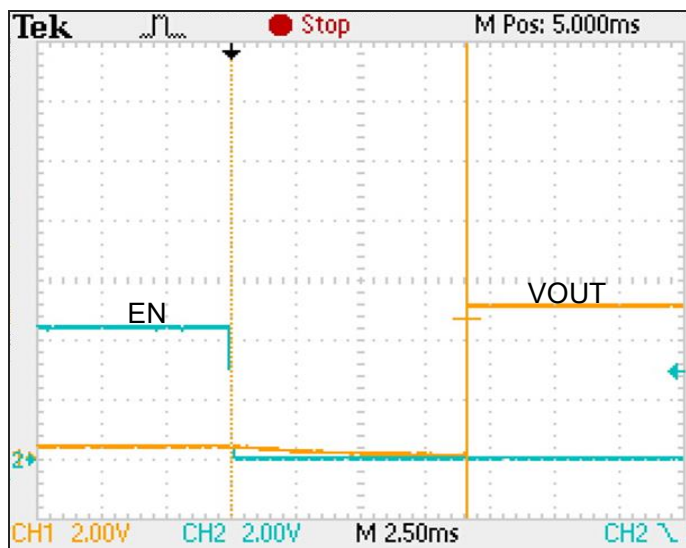

Turn on with VIN=5V

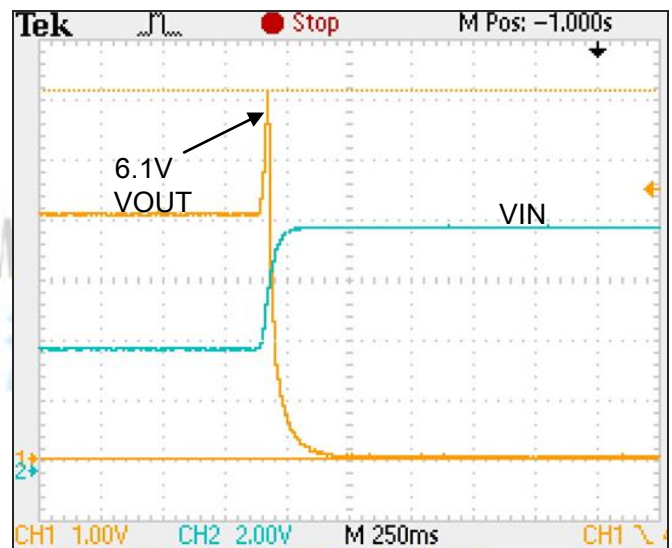

OVP waveform

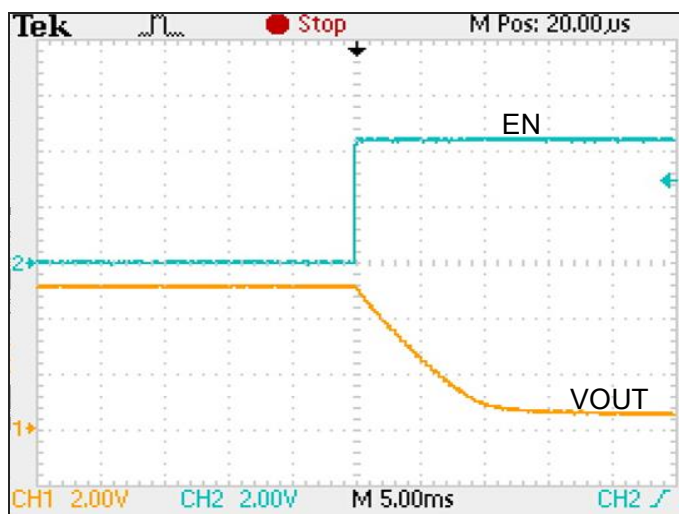

Turn off waveform with Iout=0A

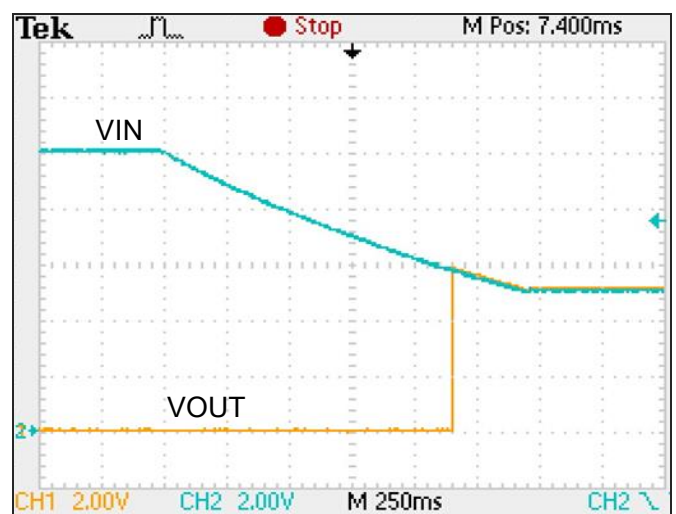

VIN falling waveform



Packaging Information

DFN-8

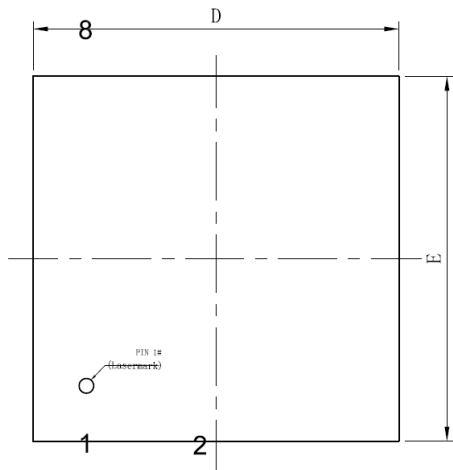

TOP VIEW

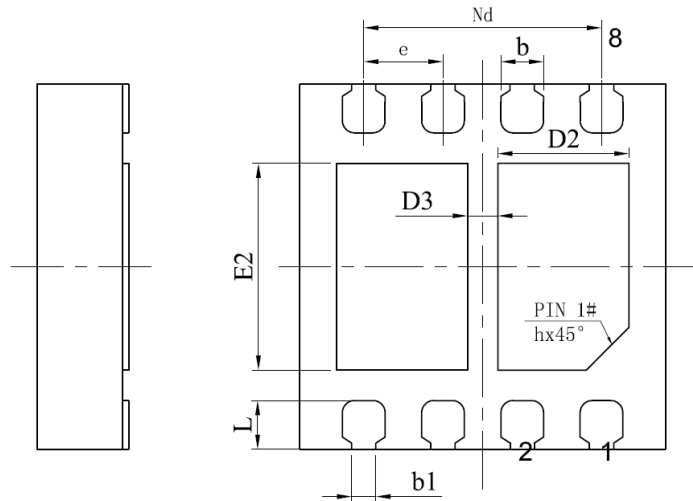

BOTTOM VIEW

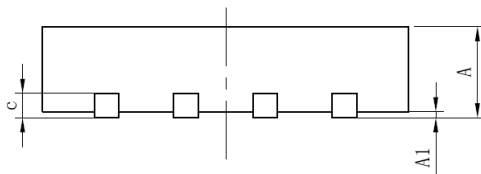

SIDE VIEW

SYMBOL	MILIMETER		
	MIN	NOM	MAX
A	0.70	0.75	0.80
A1	0	0.02	0.05
b	0.30	0.35	0.40
b1	0.20REF		
c	0.18	0.20	0.23
D	2.90	3.00	3.10
D2	0.975	1.075	1.175
D3	0.25REF		
Nd	1.90	1.95	2.00
E	2.90	3.00	3.10
E2	1.60	1.70	1.80
e	0.65BSC		
L	0.35	0.40	0.45
h	0.30	0.35	0.40

X-ON Electronics

Largest Supplier of Electrical and Electronic Components

Click to view similar products for [Power Management Specialised - PMIC category](#):

Click to view products by [LOWPOWER manufacturer](#):

Other Similar products are found below :

[P9145-I0NQGI](#) [SLG7NT4192VTR](#) [AS3729B-BWLM](#) [LNBH25SPQR](#) [ADP5080ACBZ-1-RL](#) [MC32PF3000A6EP](#) [MB39C831QN-G-EFE2](#)
[MAX9959DCCQ+D](#) [MAX1932ETC+T](#) [MAX1856EUB+T](#) [STNRG011TR](#) [IRPS5401MXI03TRP](#) [S6AE102A0DGN1B200](#)
[MMPF0100FDAEP](#) [MCZ33903DS5EK](#) [S6AE101A0DGNAB200](#) [MCZ33903DS3EK](#) [NCP6924CFCHT1G](#) [MAX17117ETJ+](#) [L9916](#) [L9915-](#)
[CB](#) [MCZ33904D5EK](#) [MCZ33905DS3EK](#) [MMPF0100FCANES](#) [MCZ33905DD3EK](#) [MMPF0100FBANES](#) [WM8325GEFL/V](#)
[MCZ33903DP5EK](#) [MCZ33905DS5EK](#) [MCZ33903D3EK](#) [MCZ33903DD5EK](#) [ADN8835ACPZ-R7](#) [MCZ33903DP5EKR2](#) [MCZ33903D5EK](#)
[MCZ33903DD3EK](#) [MMPF0100FAAZES](#) [SLG7NT4198V](#) [MIC5164YMM](#) [P9180-00NHGI](#) [NCP6914AFCAT1G](#) [TLE9261QX](#)
[TEA1998TS/1H](#) [MAX881REUB+T](#) [TLE9262QX](#) [TLE8880TN](#) [MAX8520ETP+T](#) [SLG7NT4083V](#) [ADP1031ACPZ-1-R7](#) [ADP1031ACPZ-2-](#)
[R7](#) [ADP1031ACPZ-3-R7](#)