



## 800mA Linear Li-Ion Battery Charger with Protection of Reverse Connection of Battery

### General Description

The LP4055 is a complete constant-current/constant-voltage linear charger for single cell lithium-ion batteries. Its SOT23-5/TDFN-6 package and low external component count make the LP4055 ideally suited for portable applications. Furthermore, the LP4055 is specifically designed to work within USB power specifications. No external sense resistor is needed, and no blocking diode is required due to the internal MOSFET architecture. Thermal feedback regulates the charge current to limit the die temperature during high power operation or high ambient temperature. The charge voltage is fixed at 4.2V, and the charge current can be programmed externally with a single resistor. The LP4055 automatically terminates the charge cycle when the charge current drops to 1/10th the programmed value after the final float voltage is reached. When the input supply (wall adapter or USB supply) is removed, the LP4055 automatically enters a low current state, dropping the battery drain current to less than 1µA. Other features include charge current monitor, automatic recharge and a status pin to indicate charge termination.

### Order Information

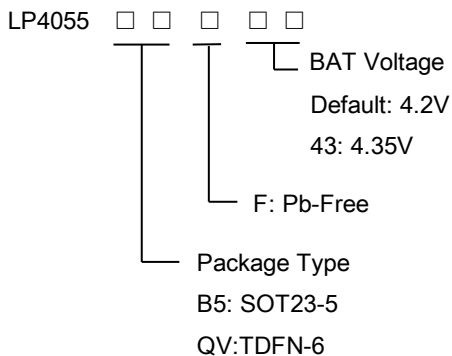

### Features

- ◆ Programmable Charge Current Up to 800mA
- ◆ No MOSFET, Sense Resistor or Blocking Diode Required
- ◆ Protection of Reverse Connection of Battery
- ◆ Constant-Current/Constant-Voltage Operation with Thermal Regulation to Maximize
- ◆ Charge Rate Without Risk of Overheating
- ◆ 4.2V /4.35V Charge Voltage with ± 1% Accuracy
- ◆ Charge Current Monitor Output for Gas Gauging
- ◆ Automatic Recharge
- ◆ 2.9V Trickle Charge Threshold
- ◆ C/10 Charge Termination
- ◆ Output OCP
- ◆ Charging OTP

### Applications

- ◇ Portable Media Players/MP3 players
- ◇ Cellular and Smart mobile phone
- ◇ PDA/DSC
- ◇ Bluetooth Applications

### Marking Information

Part	Marking	Package	Shipping
LP4055B5F	LPS BBYWX	SOT23-5	3K/REEL
LP4055QVF	LPS BBYWX	TDFN-6	4K/REEL

Marking indication:  
Y:Production year W:Production week X:Production batch.



## Typical Application Circuit

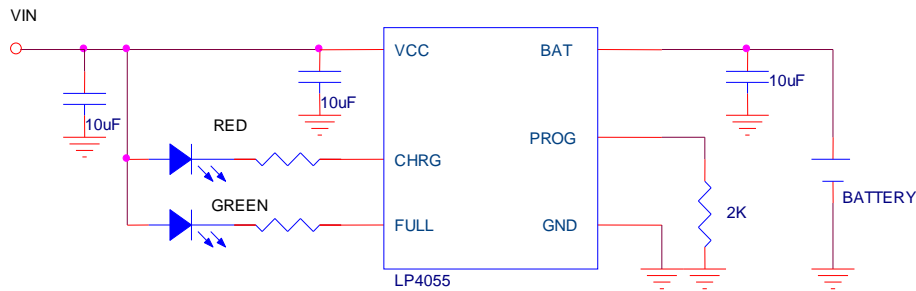

## Functional Pin Description

Package Type	Pin Configurations
SOT23-6 / TDFN-6	<p>TOP VIEW</p> <p>SOT23-5</p> <p>TDFN-6</p>

## Pin Description

Pin		Name	Description
SOT23-5	TDFN-6		
1	6	/CHRG	Open-Drain Charge Status Output. When the battery is charging, the CHRG pin is pulled low by an internal N-channel MOSFET. When the LP4055 detects an under voltage lockout condition or charge complete, CHRG is forced high impedance.
2	5,7	GND	Ground.
3	4	BAT	Charge Current Output. Provides charge current to the battery and regulates the final float voltage to 4.2V. An internal precision resistor divider from this pin sets the float voltage.
4	3	VCC	Positive Input Supply Voltage. Provide power to the charger. VCC can range from 4.5V to 6.5V and should be bypassed with at least a 1 $\mu$ F capacitor. When VCC drops to within 30mV of the BAT pin voltage, the LP4055 enters shutdown mode, dropping I <sub>BAT</sub> to less than 1 $\mu$ A.
5	1	PROG	Charge Current Program and Charge Current Monitor Pin. The charge current is programmed by connecting a 1% resistor, R <sub>PROG</sub> , to ground. When charging in constant-current mode, this pin serves to 1V. In all modes, the voltage on this pin can be used to measure the charge current using the following formula: I <sub>BAT</sub> =1000/R <sub>PROG</sub>
-	2	FULL	Open-Drain Charge Complete Status Output. When the battery charge complete, the FULL pin is pulled low by an internal N-channel MOSFET. When the LP4055 is charging, FULL is forced high impedance.



### Absolute Maximum Ratings <sup>Note 1</sup>

- ✧ Input to GND(VCC) ----- -0.3V to 10V
- ✧ BAT to GND ----- -5V to 8V
- ✧ VCC to BAT ----- 8V
- ✧ Other Pin to GND ----- -0.3V to 6V
- ✧ BAT Pin Current ----- 800mA
- ✧ BAT Short-circuit Duration ----- Continuous
- ✧ Maximum Junction Temperature ----- 150°C
- ✧ Operating Ambient Temperature Range (T<sub>A</sub>) ----- -40°C to 85°C
- ✧ Storage Temperature ----- -65°C to 165°C
- ✧ Maximum Soldering Temperature (at leads, 10 sec) ----- 260°C

**Note 1.** Stresses beyond those listed under “Absolute Maximum Ratings” may cause permanent damage to the device. These are stress ratings only, and functional operation of the device at these or any other conditions beyond those indicated in the operational sections of the specifications is not implied. Exposure to absolute maximum rating conditions for extended periods may affect device reliability.

### Thermal Information

- ✧ Maximum Power Dissipation (SOT23-5, P<sub>D</sub>, T<sub>A</sub>=25°C) ----- 0.45W
- ✧ Thermal Resistance (SOT23-5, θ<sub>JA</sub>) ----- 250°C/W
- ✧ Maximum Power Dissipation (TDFN-6, P<sub>D</sub>, T<sub>A</sub>=25°C) ----- 1.2W
- ✧ Thermal Resistance (TDFN-6, θ<sub>JA</sub>) ----- 95°C/W

### ESD Susceptibility

- ✧ HBM(Human Body Mode) ----- 2KV
- ✧ MM(Machine Mode) ----- 200V



## Electrical Characteristics

( $T_A=25^{\circ}\text{C}$ ,  $V_{CC}=5\text{V}$ , LP4055B5F, the specifications which apply over the full operating temperature range, unless otherwise noted.)

Symbol	Parameter	Condition	Min	Typ	Max	Units
$V_{CC}$	Adapter/USB Voltage Range		4.5	5	6.5	V
$I_{CC}$	Input Supply Current	Charge Mode, $R_{PROG} = 10\text{k}$		300	1000	$\mu\text{A}$
		Standby Mode (Charge Terminated)		50	200	
		Shutdown Mode ( $R_{PROG} \text{ NC}$ , $V_{CC} < V_{BAT}$ , or $V_{CC} < V_{UV}$ )			50	
$V_{FLOAT}$	Regulated Output (Float) Voltage	$0^{\circ}\text{C} \leq T_A \leq 85^{\circ}\text{C}$ , LP4055B5F	4.158	4.2	4.242	V
		$0^{\circ}\text{C} \leq T_A \leq 85^{\circ}\text{C}$ , (LP4055B5F/QVF-43)	4.3	4.35	4.4	V
$I_{BAT}$	BAT Pin Current	$R_{PROG}=10\text{k}$ , Current Mode	80	100	120	mA
		$R_{PROG}=2\text{k}$ , Current Mode	400	500	600	
		Reverse Current, $V_{BAT}=-4.2\text{V}$		-1		
		Standby Mode, $V_{BAT}=4.2\text{V}$ Shutdown Mode ( $R_{PROG} \text{ NC}$ ) Sleep Mode, $V_{CC}=0\text{V}$			-1 $\pm 2$ $\pm 2$	$\mu\text{A}$
$V_{TRIKL}$	Trickle Charge Threshold Voltage	$R_{PROG}=10\text{k}$ , $V_{BAT}$ Rising	2.8	2.9	3.0	V
$V_{TRHYS}$	Trickle Charge Hysteresis Voltage	$R_{PROG}=10\text{k}$	60	80	110	mV
$V_{UV}$	$V_{CC}$ Undervoltage Lockout Threshold	From $V_{CC}$ Low to High	3.7	3.8	3.95	V
$V_{UVHYS}$	$V_{CC}$ Undervoltage Lockout Hysteresis			500		mV
$V_{ASD}$	$V_{CC}-V_{BAT}$ Lockout Threshold Voltage			100		mV
$I_{TERM}$	Termination Current Threshold	$R_{PROG}=10\text{k}$		10		$\%I_{BAT}$
		$R_{PROG}=2\text{k}$		10		
$V_{PROG}$	PROG Pin Voltage	$R_{PROG}=10\text{k}$ , Charge Mode		1		V
$V_{CHRG/FULL}$	CHRG/FULL Pin Output Low Voltage	$I_{CHRG/FULL}=5\text{mA}$		0.35	0.6	V
$I_{CHRG/FULL}$	CHRG/FULL Pin Weak Pull-Down Current	$I_{CHRG/FULL}=5\text{mA}$		0.35	0.6	V
$\Delta V_{RECHRG}$	Recharge Battery Threshold Voltage	$V_{FLOAT}-V_{RECHRG}$	100	150	200	mV
$T_{LIM}$	Junction Temperature in Constant Temperature Mode			150		$^{\circ}\text{C}$
$R_{ON}$	Power FET "ON" Resistance (Between $V_{CC}$ and BAT)			500		m $\Omega$
$t_{SS}$	Soft-Start Time	$I_{BAT}=0$ to $I_{BAT}=1000\text{V}/R_{PROG}$		200		$\mu\text{s}$



## Application Information

The LP4055 is a single cell lithium-ion battery charger using a constant-current/constant-voltage algorithm. It can deliver up to 800mA of charge current (using a good thermal PCB layout) with a final float voltage accuracy of  $\pm 1\%$ . The LP4055 includes an internal P-channel power MOSFET and thermal regulation circuitry. No blocking diode or external current sense resistor is required; thus, the basic charger circuit requires only three external components. Furthermore, the LP4055 is capable of operating from a USB power source.

### Normal Charge Cycle

A charge cycle begins when the voltage at the VCC pin rises above the UVLO threshold level and a 1% program resistor is connected from the PROG pin to ground or when a battery is connected to the charger output. If the BAT pin is less than 2.9V, the charger enters trickle charge mode to bring the battery voltage up to a safe level for full current charging.

When the BAT pin voltage rises above 2.9V, the charger enters constant-current mode, where the programmed charge current is supplied to the battery. When the BAT pin approaches the final float voltage (4.2V), the LP4055 enters constant-voltage mode and the charge current begins to decrease. The charge cycle ends when the charge current drops to 1/10 of the programmed value.

### Programming Charge Current

The charge current is programmed using a single resistor from the PROG pin to ground. The battery charge current is 1000 times the current out of the PROG pin. The program resistor and the charge current are calculated using the following equations:

$$R_{PROG} = 1000V / I_{BAT}$$

$$I_{BAT} = 1000V / R_{PROG}$$

The charge current out of the BAT pin can be determined at any time by monitoring the PROG pin voltage using the following equation:

$$I_{BAT} = V_{PROG} / R_{PROG} \times 1000$$

### Charge Termination

A charge cycle is terminated when the charge current falls to 1/10th the ISET rammed value after the final float voltage is reached. This condition is detected by using an internal, filtered comparator to monitor the ISET pin. When the ISET pin voltage falls below 200mV for longer than  $t_{TERM}$  (typically 1ms), charging is terminated. The charge current is latched off and the LP4055 enters standby mode, where the input supply current drops to 200µA. In this state, all loads on the BAT pin must be supplied by the battery. (Note: C/10 termination is disabled in trickle charging and thermal limiting modes).

### Charge Status Indicator (CHRG&FULL)

The charge status output has two different states: strong pull-down (~5mA) and high impedance. The strong pull-down state indicates that the LP4055 is in a charge cycle. Once the charge cycle has terminated, the pin state is determined by under voltage lockout conditions. High impedance indicates that the charge cycle complete or the LP4055 is in under voltage lockout mode: either  $V_{CC}$  is less than 100mV above the BAT pin voltage or insufficient voltage is applied to the VCC pin. A microprocessor can be used to distinguish between these two states.

Function	CHRG	FULL
Charging	LOW	HIGH
Charge Complete	HIGH	LOW

### Charge Current

An internal thermal feedback loop reduces the programmed charge current if the die temperature attempts to rise above a preset value of approximately 150°C. This feature protects the LP4055 from excessive temperature and allows the user to push the limits of the power handling capability of a given circuit board without risk of damaging the LP4055. The charge current can be set according to typical (not worst-case) ambient temperature with the assurance that the charger will automatically reduce the current in worst-case conditions. SOT power considerations are discussed further in the Applications Information section.



## Stability Considerations

The constant-voltage mode feedback loop is stable without an output capacitor provided a battery is connected to the charger output. With no battery present, an output capacitor is recommended to reduce ripple voltage. When using high value, low ESR ceramic capacitors, it is recommended to add a 1Ω resistor in series with the capacitor. No series resistor is needed if tantalum capacitors are used.

## Manual Shutdown

At any point in the charge cycle, the LP4055 can be put into shutdown mode by removing R<sub>PROG</sub>. This reduces the battery drain current to less than 1μA and the supply current to less than 1μA. A new charge cycle can be initiated by reconnecting the program resistor. The CHRG pin is in a high impedance state if the LP4055 is in under voltage lockout mode: either V<sub>CC</sub> is within 100mV of the BAT pin voltage or insufficient voltage is applied to the VCC pin.

## Automatic Recharge

Once the charge cycle is terminated, the LP4055 continuously monitors the voltage on the BAT pin using a comparator with a 2ms filter time (t<sub>RECHRG</sub>). A charge cycle restarts when the battery voltage falls below 4.05V (which corresponds to approximately 80% to 90% battery capacity). This ensures that the battery is kept at or near a fully charged condition and eliminates the need for periodic charge cycle initiations. CHRG output enters a strong pull-down state during recharge cycles.

## Under voltage Lockout (UVLO)

An internal under voltage lockout circuit monitors the input voltage and keeps the charger in shutdown mode until V<sub>CC</sub> rises above the under voltage lockout threshold. The UVLO circuit has a built-in hysteresis of 500mV. Furthermore, to protect against reverse current in the power MOSFET, the UVLO circuit keeps the charger in shutdown mode if V<sub>CC</sub> falls to within 30mV of the battery voltage. If the UVLO comparator is tripped, the charger will not come out of shutdown mode until V<sub>CC</sub> raises 100mV above the battery voltage.

## Power Dissipation ( SOT23-5 )

The conditions that cause the LP4055 to reduce charge current through thermal feedback can be approximated by considering the power dissipated in the IC. Nearly all of this power dissipation is generated by the internal MOSFET—this is calculated to be approximately:

$$P_D = (V_{CC} - V_{BAT}) \times I_{BAT}$$

Where PD is the power dissipated, VCC is the input supply voltage, VBAT is the battery voltage and IBAT is the charge current. The approximate ambient temperature at which the thermal feedback begins to protect the IC is:

$$T_A = 150^\circ\text{C} - P_D \times \theta_{JA}$$

$$T_A = 150^\circ\text{C} - (V_{CC} - V_{BAT}) \times I_{BAT} \times \theta_{JA}$$

## VCC Bypass Capacitor

Many types of capacitors can be used for input bypassing; however, caution must be exercised when using multilayer ceramic capacitors. Because of the self-resonant and high Q characteristics of some types of ceramic capacitors, high voltage transients can be generated under some start-up conditions, such as connecting the charger input to a live power source. Adding a 1.5Ω resistor in series with an X5R ceramic capacitor will minimize start-up voltage transients.

## Layout Considerations

For the main current paths as indicated in bold lines, keep their traces short and wide.

Put the input and output capacitor as close as possible to the device pins (VCC, BAT and GND).

Connect all analog grounds to a common node and then connect the common node to the power ground behind the output capacitors.



### Packaging Information

#### SOT23-5

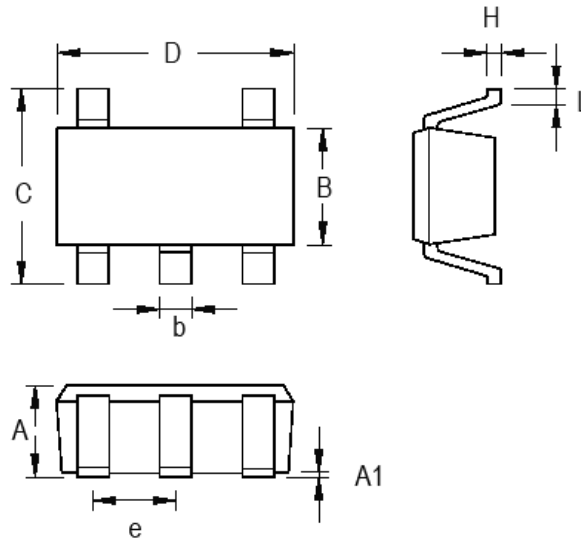

Symbol	Dimensions In Millimeters		Dimensions In Inches	
	Min	Max	Min	Max
A	0.889	1.295	0.035	0.051
A1	0.000	0.152	0.000	0.006
B	1.397	1.803	0.055	0.071
b	0.356	0.559	0.014	0.022
C	2.591	2.997	0.102	0.118
D	2.692	3.099	0.106	0.122
e	0.838	1.041	0.033	0.041
H	0.080	0.254	0.003	0.010
L	0.300	0.610	0.012	0.024

**SOT-23-5 Surface Mount Package**



TDFN-6

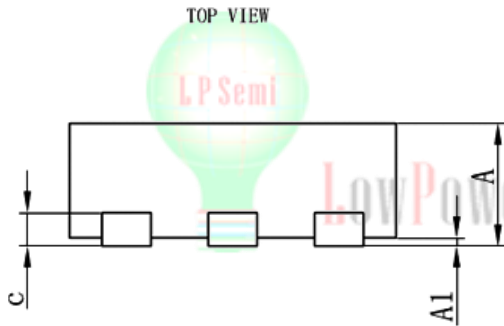
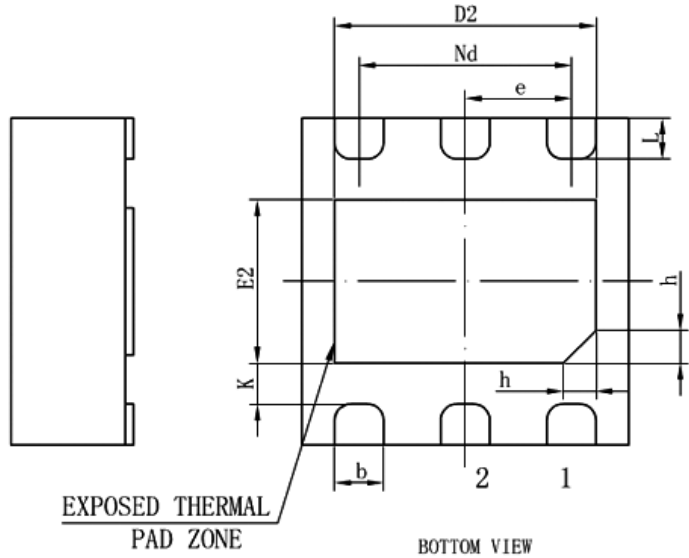
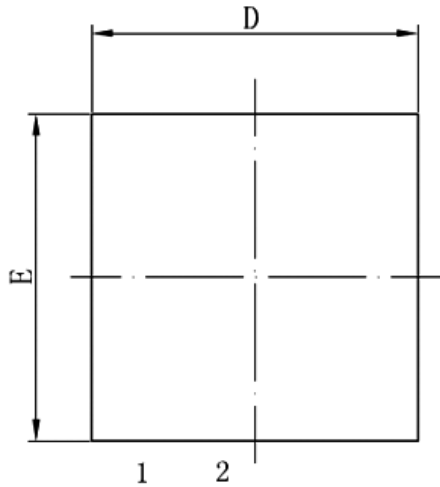

SYMBOL	MILLIMETER		
	MIN	NOM	MAX
A	0.70	0.75	0.80
A1	0	0.02	0.05
b	0.25	0.30	0.35
c	0.18	0.20	0.25
D	1.90	2.00	2.10
D2	1.50	1.60	1.70
e	0.65BSC		
Nd	1.30BSC		
E	1.90	2.00	2.10
E2	0.90	1.00	1.10
K	0.20	-	-
L	0.20	0.25	0.30
h	0.15	0.20	0.25
SIZE OF L/F (MIL)	69X47		



## X-ON Electronics

Largest Supplier of Electrical and Electronic Components

*Click to view similar products for [Battery Management](#) category:*

*Click to view products by [LOWPOWER](#) manufacturer:*

Other Similar products are found below :

[MP2602DQ-LF-P](#) [MP26053DQ-LF-Z](#) [MP2611GL-P](#) [NCP347MTAHTBG](#) [LM3658SD-AEV/NOPB](#) [MP2607DL-LF-P](#) [MP26121DQ-LF-P](#)  
[MP26123DR-LF-P](#) [MP2633GR-P](#) [MP2637GR-P](#) [BQ24212EVM-678](#) [NCP1855FCCT1G](#) [MP2636GR-P](#) [FAN54063UCX](#)  
[MAX14680EWC+T](#) [MAX14634EWC+T](#) [DS2745U+T&R](#) [MAX14578EETE+T](#) [DS2781EVKIT+](#) [DS2781E+T&R](#) [MP2605DQ-LF-P](#)  
[DS2710G+T&R](#) [MAX17040G+T](#) [MAX14525ETA+T](#) [MP2615GQ-P](#) [MAX14578EEWC+T](#) [LC05132C01NMTTGTG](#) [MAX8971EWP+T](#)  
[MAX14630EZK+T](#) [MAX1873TEEE+T](#) [PSC5415A](#) [AUR9811DGD](#) [SN2040DSQR](#) [DS2715BZ+T&R](#) [MAX1508ZETA+T](#)  
[MAX14921ECS+T](#) [MAX77301EWA+T](#) [BD8668GW-E2](#) [MAX16024PTBS+T](#) [DS2715Z+T&R](#) [MAX16024LTBZ18+T](#) [DS2782E+T&R](#)  
[DS2782G+T&R](#) [MAX1908ETI+T](#) [ISL95522IRZ](#) [ISL95522HRZ](#) [ARD00558](#) [NCP4371AAEDR2G](#) [BD8665GW-E2](#) [MAX8934EETI+T](#)