



2.1A Power Switch with Programmable Current Limit

General Description

The LPW5209 is an integrated power switch for self-powered and bus-powered Universal Series Bus (USB) applications. A built-in charge pump is used to drive the N-Channel MOSFET that is free of parasitic body diode to eliminate any reversed current flow across the switch when it is powered off. Its low quiescent current (16µA) and small package (SOT23-5) is particularly suitable in battery-powered portable equipment.

Several protection functions include soft start to limit inrush current during plug-in, current limiting at 2.1A to meet USB power requirement, and thermal shutdown to protect damage under over current conditions.

Features

- ◆ 80mΩ Low $R_{DS(ON)}$, High-side N-MOSFET
- ◆ 2100mA Programmable current limit
- ◆ 2.5V to 6V Input Voltage
- ◆ Low Quiescent Current:30µA
- ◆ Soft Start Function
- ◆ Built-In Short-Circuit Protection
- ◆ Built-in Thermal Protection
- ◆ RoHS Compliant and 100% Lead (Pb)-Free

Typical Application Circuit

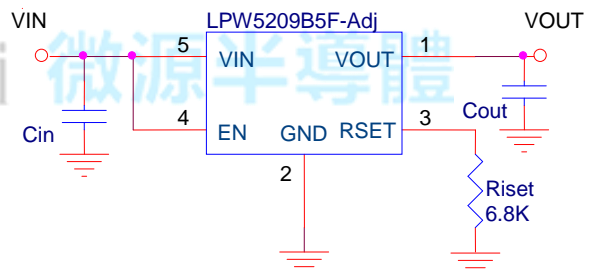

Order Information

Ordering Number	Current	Package
LPW5209AB5F	Adjustable	SOT23-5
LPW5209B5F-21	2.1A	
LPW5209B5F-11	1.1A	
LPW5209B5F-06	600mA	

Applications

- ✧ Power Switch
- ✧ USB Device
- ✧ Battery Charger Circuits

Marking Information

Device	Marking	Shipping
LPW5209AB5F	LPS C0YWX	3K/REEL
LPW5209B5F-21	LPS C1YWX	
LPW5209B5F-11	LPS C2YWX	
LPW5209B5F-06	LPS C3YWX	
Marking indication: Y:Production year W:Production week X:Production batch		



Functional Pin Description

Package Type	Pin Configurations
SOT23-5	<p style="text-align: center;">Top View</p>

Pin Description

Name	Pin		Description
	LPW5209A	LPW5209-21/11/06	
VOUT	1	1	Output to system pin.
GND	2	2	Ground.
ISET	3	3	Connect a resistor to GND for setting current limit.
NC		3	No connector
EN	4	4	Device Enable (active High).
VIN	5	5	Input pin.



Function Block Diagram

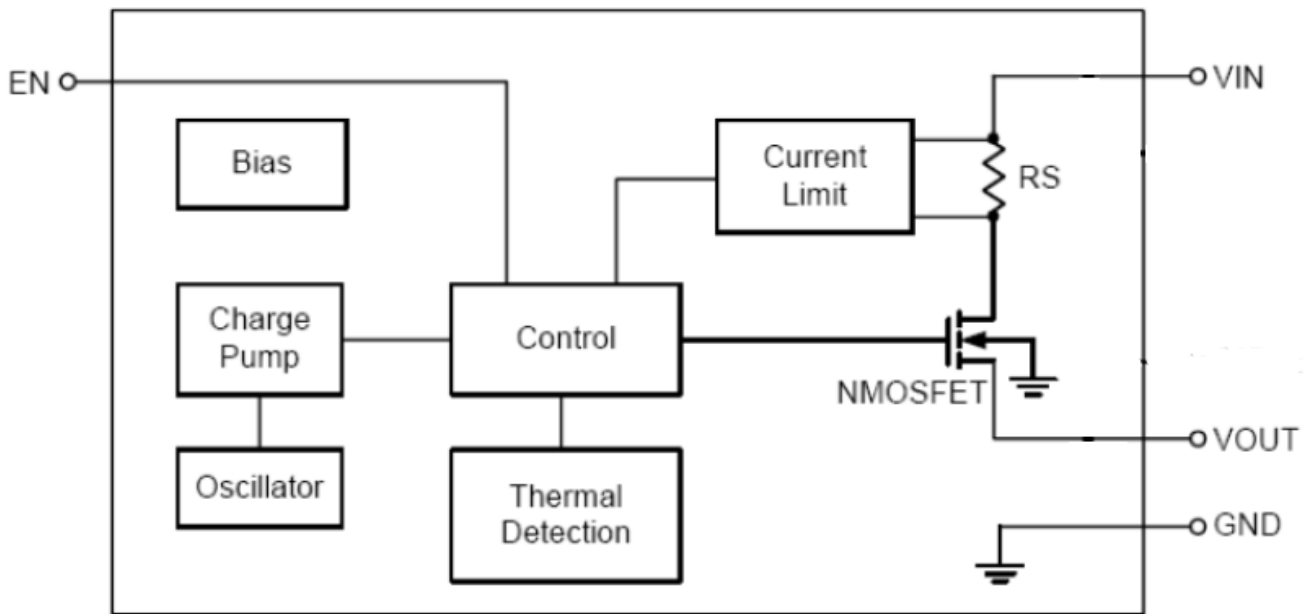

Absolute Maximum Ratings ^{Note 1}

- ✧ Input Voltage to GND ----- 7V
- ✧ Output Voltage to GND ----- 7V
- ✧ Other pin to GND ----- 6V
- ✧ Maximum Junction Temperature ----- 150°C
- ✧ Operating Ambient Temperature Range (T_A) ----- -40°C to 85°C
- ✧ Maximum Soldering Temperature (at leads, 10 sec) ----- 260°C

Note 1. Stresses beyond those listed under “Absolute Maximum Ratings” may cause permanent damage to the device. These are stress ratings only, and functional operation of the device at these or any other conditions beyond those indicated in the operational sections of the specifications is not implied. Exposure to absolute maximum rating conditions for extended periods may affect device reliability.

Thermal Information

- ✧ Maximum Power Dissipation (SOT23-5, P_D, T_A=25°C) ----- 0.45W
- ✧ Thermal Resistance (SOT23-5, θ_{JA}) ----- 250°C/W

ESD Susceptibility

- ✧ HBM(Human Body Mode) ----- 2KV
- ✧ MM(Machine Mode) ----- 200V



Electrical Characteristics

(Over recommended operating conditions unless specified otherwise, $T_A=25^{\circ}\text{C}$)

Symbol	Parameter	Condition	Min	Typ	Max	Units
V_{IN}	Input Voltage		2.5		6	V
I_{OUT}	Output Current Limit	LPW5209B5F-Adj, $R_{ISET}=10\text{K}$		680		mA
		PW5209B5F-Adj, $R_{ISET}=6.8\text{K}$		1000		
		PW5209B5F-Adj, $R_{ISET}=3.4\text{K}$		2000		
		LPW5209B5F-21		2100		
		PW5209B5F-11		1100		
		PW5209B5F-06		600		
$R_{DS(ON)}$	Output N-MOSFET $R_{DS(ON)}$	$I_{out}=1\text{A}$		80	100	m Ω
I_Q	Quiescent Current	$V_{IN}=3\text{V}$		30	50	μA
I_{SHDN}	Shutdown Current	$V_{EN}=\text{GND}$		0.1	1	μA
$V_{EN(L)}$	Enable Threshold Low				0.4	V
$V_{EN(H)}$	Enable Threshold High		1.4			V
I_{EN}	Input High Current	$V_{IN}=V_{EN}=5.0\text{V}$		5		μA
OTP	Over temperature protection			150		$^{\circ}\text{C}$
OTP-HYS	Over temperature hysteresis			20		$^{\circ}\text{C}$



Typical Operating Characteristics

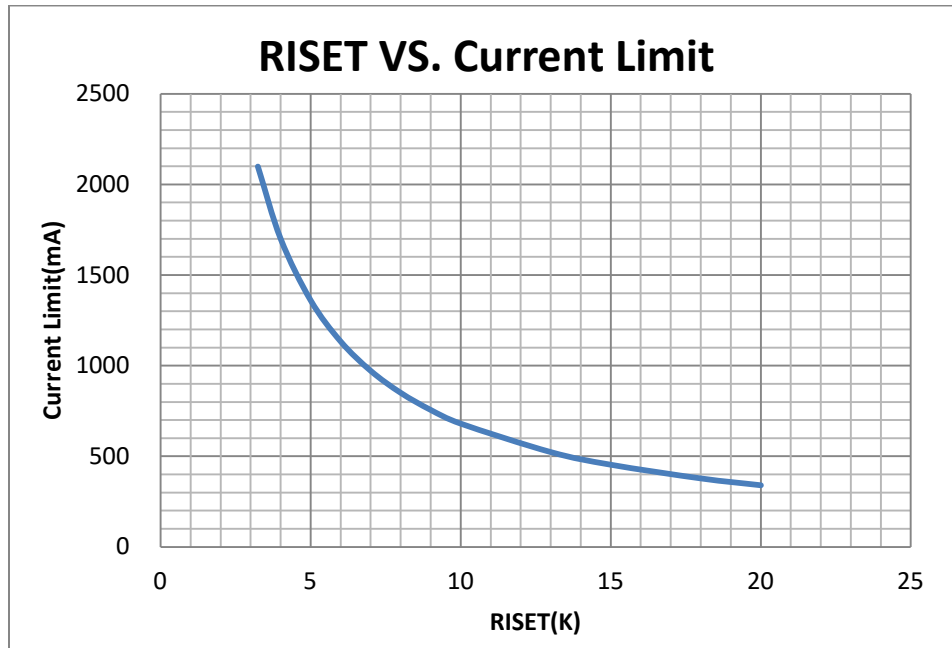



Application Information

The LPW5209 are single N-Channel MOSFET high-side power switches with active-high enable input, optimized for self-powered and bus-powered Universal Serial Bus (USB) applications. The LPW5209 equipped with a charge pump circuitry to drive the internal NMOS switch; the switch's low RDS(ON), 80mΩ, meets USB voltage drop requirements.

Input and Output

VIN (input) is the power source connection to the internal circuitry and the drain of the MOSFET. VOUT (output) is the source of the MOSFET. In a typical application, current flows through the switch from VIN to VOUT toward the load. If VOUT is greater than VIN, current will flow from VOUT to VIN since the MOSFET is bidirectional when on. Unlike a normal MOSFET, there is no a parasitic body diode between drain and source of the MOSFET, the LPW5209 prevents reverse current flow if VOUT being externally forced to a higher voltage than VIN when the output disabled ($V_{EN} < 0.4V$).

Chip Enable Input

The switch will be disabled when the EN pin is in a logic low condition. During this condition, the internal circuit is turned off, reducing the supply current to 0.1μA typical. The maximum guaranteed voltage for a logic low at the EN pin is 0.4V. A minimum guaranteed voltage of 1.4V at the EN pin will turn the LPW5209 back on. Floating the input may cause unpredictable operation. EN should not be allowed to go negative with respect to GND. The EN pin may be directly tied to VIN to keep the part on.

Soft Start for Hot Plug-In Applications

In order to eliminate the upstream voltage droop caused by the large inrush current during hot-plug events, the “soft-start” feature effectively isolates the power source from extremely large capacitive loads, satisfying the USB voltage droop requirements.

Thermal Shutdown

Thermal shutdown is employed to protect the device from damage if the die temperature exceeds approximately 150°C. If enabled, the switch automatically restarts when the die temperature falls 20°C. The output will continue to cycle on and off until the device is disabled or the fault is removed.



Packaging Information

SOT23-5

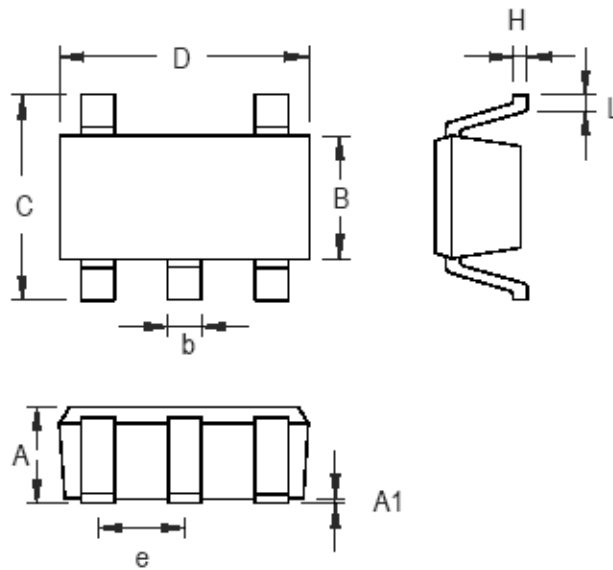

Symbol	Dimensions In Millimeters		Dimensions In Inches	
	Min	Max	Min	Max
A	0.889	1.295	0.035	0.051
A1	0.000	0.152	0.000	0.006
B	1.397	1.803	0.055	0.071
b	0.356	0.559	0.014	0.022
C	2.591	2.997	0.102	0.118
D	2.692	3.099	0.106	0.122
e	0.838	1.041	0.033	0.041
H	0.080	0.254	0.003	0.010
L	0.300	0.610	0.012	0.024

SOT-23-5 Surface Mount Package

X-ON Electronics

Largest Supplier of Electrical and Electronic Components

Click to view similar products for [Power Switch ICs - Power Distribution](#) category:

Click to view products by [LOWPOWER](#) manufacturer:

Other Similar products are found below :

[AP22652AW6-7](#) [MAPDCC0001](#) [L9349TR-LF](#) [MAPDCC0005](#) [NCP45520IMNTWG-L](#) [VND5050K-E](#) [MP6205DD-LF-P](#)
[MC15XS3400DHFKR2](#) [FPF1015](#) [FPF1018](#) [DS1222](#) [TCK2065G,LF](#) [SZNCP3712ASNT3G](#) [L9781TR](#) [NCP45520IMNTWG-H](#)
[MC17XS6500BEK](#) [SP2526A-1EN-L/TR](#) [SP2526A-2EN-L/TR](#) [MAX4999ETJ+T](#) [MC22XS4200BEK](#) [MAX14575BETA+T](#) [VN1160C-1-E](#)
[VN750PEP-E](#) [TLE7244SL](#) [BTS50060-1EGA](#) [MAX1693HEUB+T](#) [MC07XSG517EK](#) [TLE7237SL](#) [MIC2033-05BYMT-T5](#) [MIC2033-](#)
[12AYMT-T5](#) [MIC2033-05BYM6-T5](#) [MP6513LGJ-P](#) [NCP3902FCCTBG](#) [AP22811BW5-7](#) [SLG5NT1437VTR](#) [SZNCP3712ASNT1G](#)
[NCV330MUTBG](#) [DML1008LDS-7](#) [MAX4987AEETA+T](#) [KTS1670EDA-TR](#) [MAX1694EUB+T](#) [KTS1640QGDV-TR](#) [KTS1641QGDV-TR](#)
[IPS160HTR](#) [BTS500251TADATMA2](#) [NCV451AMNWTBG](#) [MC07XS6517BEKR2](#) [SIP43101DQ-T1-E3](#) [DML10M8LDS-13](#)
[MAX1922ESA+C71073](#)