



USB DCP Control IC

General Description

The LP102 is a USB Dedicated Charging Port controller. The feature monitors USB D+/D- data line's signal, and automatically adjusts output voltage of power source output to optimize charge time.

The LP102 was supported USB Battery Charging Specification Revision 1.2(BC1.2), DCP apply the 2.7V operation function for Divider 3 mode.

Other features include under-voltage lockout (UVLO). The LP102 is available in a space saving SOT23-6 package.

Order Information

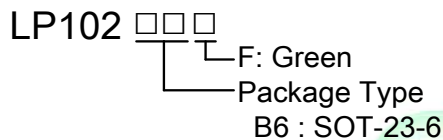

Features

- ◆ Power consumption below 1mW@5 V
- ◆ Support USB BC1.2
- ◆ Support Short Mode per Chinese Telecommunication Industry Standard YD/T 1591-2009
- ◆ Divide3 DCP, apply D+/D- is 2.7V/2.7V
- ◆ Support USB DCP 1.2V on Data Line
- ◆ Under-Voltage Protection
- ◆ Available in SOT23-6
- ◆ RoHS Compliant and Halogen Free

Applications

- ◆ Battery Charge Port
- ◆ USB Dedicated Charging Port
- ◆ Wall-Adapter

Marking Information

Device	Marking	Package	Shipping
LP102	LP102 YWX	SOT23-6	3K/REEL
Y: Y is year code. W: W is week code. X: X is series number.			



Typical Application Circuit

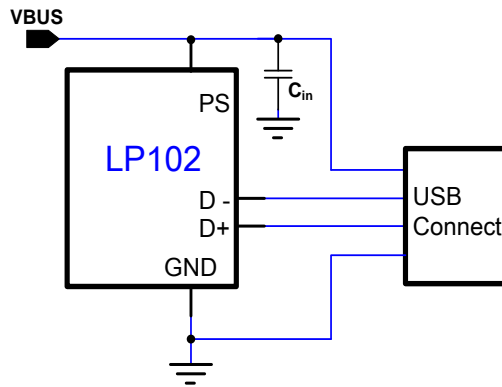

Figure 1. Typical Application Circuit of LP102 with SOT23-6 Package Type.

Pin Configuration

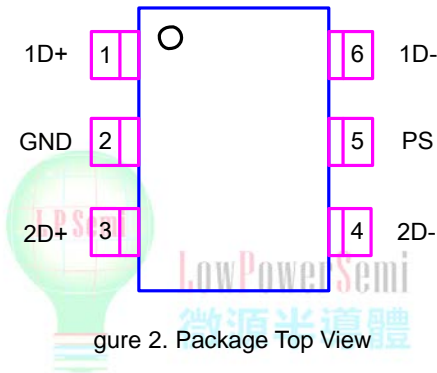

Figure 2. Package Top View



Function Block Diagram

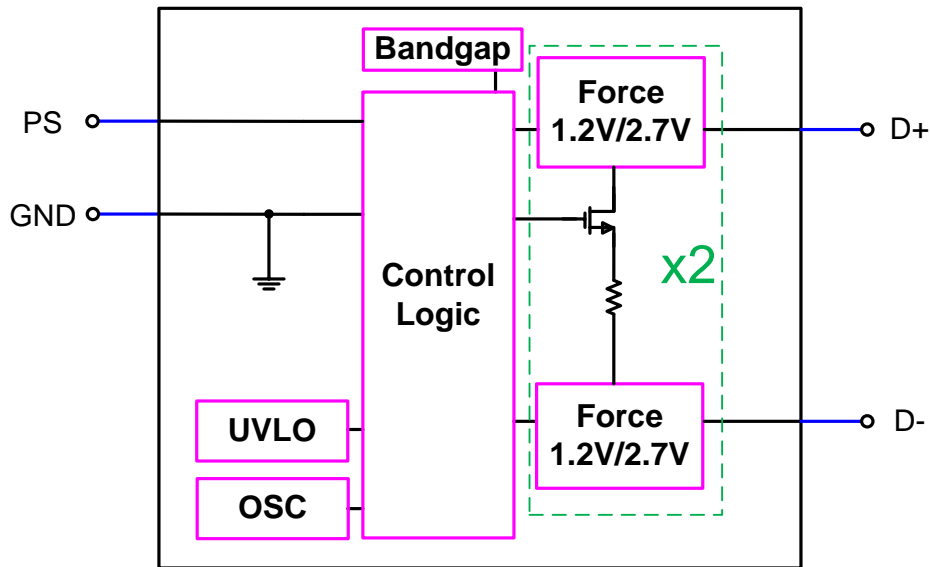

Figure 3. Function Block Diagram

Functional Pin Description

Pin NO.	SOT23-6	Description
1D+	1	USB D+ data line port 1.
GND	2	Ground.
2D+	3	USB D+ data line port 2.
2D-	4	USB D- data line port 2.
PS	5	Power Source. Connection point for an external bypass capacitor for the internally generated supply voltage.
1D-	6	USB D- data line port 1.



Absolute Maximum Ratings ^{Note2}

◇ PS to GND	-----	-0.3V to +6.5V
◇ 1D+, 1D-, 2D+, 2D- to GND	-----	-0.3V to +6.5V
◇ Operating Junction Temperature Range (T _J)	-----	-40°C to 150°C
◇ Operation Ambient Temperature Range	-----	-40°C to +105°C
◇ Storage Temperature Range	-----	-65°C to +150°C
◇ Maximum Soldering Temperature (at leads, 10sec)	-----	+260°C

Note2. Stresses beyond those listed under "Absolute Maximum Ratings" may cause permanent damage to the device. These are stress ratings only, and functional operation of the device at these or any other conditions beyond those indicated in the operational sections of the specifications is not implied. Exposure to absolute maximum rating conditions for extended periods may affect device reliability.

Thermal Information

◇ Thermal Resistance		
SOT23-6, θ_{JA}	-----	99.1°C/W
SOT23-6, θ_{JC}	-----	67°C/W





Electrical Characteristics

($V_{BUS} = 5V$, $T_A = 25^\circ C$ (Unless Otherwise Specified))

Parameter	Symbol	Test Conditions	Min	Typ	Max	Units
Supply and Reference Function						
Power Source UVLO Threshold	V_{UVLO}		3.9	4.1	4.3	V
UVLO Threshold Hysteresis	V_{UVLO_Hys}			0.1		V
Power Source Current	I_{PS}			150	200	μA
Battery Charging Specification Revision 1.2 (BC 1.2)						
D+ and D- Shorting Resistance	R_{BC_SHORTx}	$V_{D+}=0.8V$		150	200	Ω
Resistance between D+/D- and GND	R_{BC_DISx}		350	656	1150	k Ω
D+ Low Voltage Detach	V_{D+L_DETx}		310	330	350	mV
D+ Low Voltage Detach Hysteresis	$V_{D+_DETx_Hys}$			50		mV
Dedicated Charging Port Divide Mode(DCP Divide 3 mode)						
DCP2.7V Data Line Output Voltage	$V_{DCP2.7V}$		2.57	2.7	2.84	V
DCP2.7V Data Line Output Resistance	$R_{DCP2.7V}$		24	30	36	k Ω
Dedicated Charging Port 1.2V Mode(DCP 1.2V mode)						
DCP1.2V Data Line Output Voltage	$V_{DCP1.2V}$		1.12	1.2	1.28	V
DCP1.2V Data Line Output Resistance	$R_{DCP1.2V}$		80	100	120	k Ω



Application Information

The LP102 is a USB Dedicated Charging Port controller. It monitors USB D+/D- data line's signal, and automatically adjusts output voltage of power source output to optimize charge time.

Under Voltage Lockout (UVLO)

The LP102 had an UVLO internal circuit that enable the device once the voltage on the V_{PS} voltage exceeds the UVLO threshold voltage.

DCP Mode

A dedicated charging port (DCP) is a downstream port on a device that outputs power through a USB connector, which generally allows portable devices to fast charge at their maximum rated current. A USB charger is a device with a DCP, such as a power bank or car charger. A DCP is identified by the electrical characteristics of its data lines. The following DCP identification circuits are usually used to meet the handshaking detections of different portable devices.

Data Line		LP102
D+	D-	DCP Mode
2.7V	2.7V	Divider 3
1.2V	1.2V	DCP 1.2V Mode
Short		BC1.2 and YD/T1591-2009

The LP102 integrate an auto-detect feature to support divider mode, short mode and 1.2V modes. The device operated D+/D- driver 2.7V output normally. If a BC1.2 compliant device is attached, the LP102 will switches into short mode automatically. If a device compliant with the 1.2V charging scheme is attached, 1.2V is applied on both the D+ pin and the D- pin. DCP auto-detect feature is cost effective, it doesn't need external element.

Battery Charging Specification Revision 1.2(BC1.2)

The BC1.2 Specification defines the protocol necessary to allow portable equipment to determine what type of port it is connected to so that it can allot its maximum allowable current drawn.

Simply put, the portable device outputs a nominal 0.6V output to one data line, and detected the other one data line.

DCP 1.2V Mode

The LP102 have the auto-detect feature that monitors the D+ and D- line voltages of the USB connector, providing the correct voltage data on the D+ and D- pins for support portable devices to fast charge.

Divider Mode

There are three charging schemes for divider DCP. They are named after Divider1, Divider2, and Divider3. The Divider 3 charging scheme is used for 12-W adapters, and applies 2.7 V on D+ and D- lines.

Layout Consideration

The proper PCB layout and component placement are critical for all circuit. Here are some suggestions to the layout of LP102 design.

1. Connected all ground together with one uninterrupted ground plane, which include power ground and analog ground.
2. The input capacitor should be located as closed as possible to the VPS and ground plane.

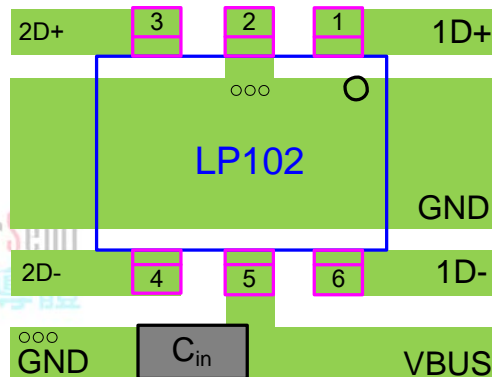
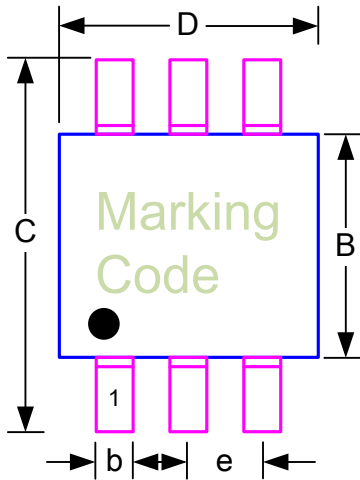

Figure 4. Recommended PCB Layout Diagram



Outline Information

SOT23-6 Package (Unit: mm)



SYMBOLS UNIT	DIMENSION IN MILLIMETER	
	MIN	MAX
A	0.700	1.000
A1	0.000	0.100
B	1.397	1.803
b	0.300	0.559
C	2.591	3.000
D	2.692	3.099
e	0.838	1.041
H	0.080	0.254
L	0.300	0.610

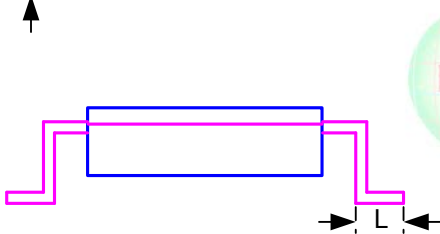
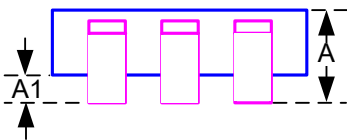

X-ON Electronics

Largest Supplier of Electrical and Electronic Components

Click to view similar products for [USB Interface IC](#) category:

Click to view products by [LOWPOWER](#) manufacturer:

Other Similar products are found below :

[TUSB1146RNQT](#) [TUSB1146IRNQT](#) [CY7C65210-24LTXI](#) [CY7C69356-48LTXC](#) [CYUSB2304-68LTXI](#) [CY7C65642-48AXCT](#) [CYPD2119-24LQXI](#) [CYUSB3328-88LTXI](#) [USB2227-NU-11](#) [USB2251-NU-06](#) [USB3319C-GJ-TR](#) [USB3370B-EZK-TR](#) [USB5537B-4100AKZE](#) [USB3347-CP](#) [USB2230-NU-02](#) [USB2229-NU-02](#) [CG7648AM](#) [W83627HG-AW](#) [CY7C64225-28PVXCT](#) [CY7C65215A-32LTXI](#) [CYPD2120-24LQXI](#) [CYWB0164BB-BZXI](#) [CYWB0224ABS-BZXI](#) [CY7C65211A-24LTXI](#) [USB5807T-I/KD](#) [USB5742-I/2G](#) [USB3331E-GL-TR](#) [USB3321C-GL-TR](#) [USB1T1103MHX](#) [USB1T1103MPX](#) [USB5742/2G](#) [MAX3301EETJ+T](#) [CYPD2122-20FNXIT](#) [CYPD2122-24LQXIT](#) [LIF-UC120-SWG36ITR50](#) [MAX3456EETE+T](#) [LIF-UC120-CM36ITR50](#) [UPD360-C/6HX](#) [USB2228-NU-11](#) [UPD360-B/6HX](#) [PI3EQX7841ZDEX](#) [CYPD4225-40LQXI](#) [LAN7800-I/VSX](#) [UPD360T-B/6HX](#) [UPD360-A/6HX](#) [LAN7800/VSX](#) [MAX20037ATIB/V+](#) [MP5030CGQH-P](#) [USB7056/KDX](#) [STUSBCD01BJR](#)