



## 1.2A Single-chip Li-ion Charge with Protection of Reverse Connection of Battery

### General Description

The LP28057 is a complete constant-current/constant-voltage linear charger for single cell lithium-ion batteries. Its ESOP-8 package and low external component count make the LP28057 ideally suited for portable applications. No external sense resistor is needed, and no blocking diode is required due to the internal MOSFET architecture. Thermal feedback regulates the charge current to limit the die temperature during high power operation or high ambient temperature. The charge voltage is fixed at 4.2V, and the charge current can be ISET rammmed externally with a single resistor. The LP28057 automatically terminates the charge cycle when the charge current drops to 1/10th the ISET rammmed value after the final float voltage is reached. When the input supply is removed, the LP28057 automatically enters a low current state, dropping the battery drain current to less than 1µA. The LP28057 can be put into shutdown mode, reducing the supply current to 1µA.

Other features include charge current monitor, under voltage lockout, automatic recharge and a status pin to indicate charge termination and the presence of an input voltage.

### Order Information

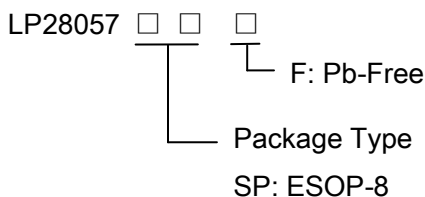

### Features

- ◆ Protection of Reverse Connection of Battery
- ◆ Programmable Charge Current Up to 1200mA
- ◆ No MOSFET, Sense Resistor or Blocking Diode Required
- ◆ Constant-Current/Constant-Voltage Operation with Thermal Regulation to Maximize Charge Rate Without Risk of Overheating
- ◆ 4.2V Charge Voltage with ± 1% Accuracy
- ◆ Short-circuit protection
- ◆ 1µA Supply Current in Shutdown
- ◆ Consumption Available in ESOP-8 Package
- ◆ RoHS Compliant and 100% Lead (Pb)-Free

### Applications

- ✧ Portable Media Players/MP3 players
- ✧ Cellular and Smart mobile phone
- ✧ PDA/DSC
- ✧ Bluetooth Applications

### Marking Information

Device	Marking	Package	Shipping
LP28057SPF	LPS LP28057 YWX	SP:ESOP-8	2.5K/REEL
Marking indication: Y:Production year W:Production week X:Production batch.			



## Typical Application Circuit

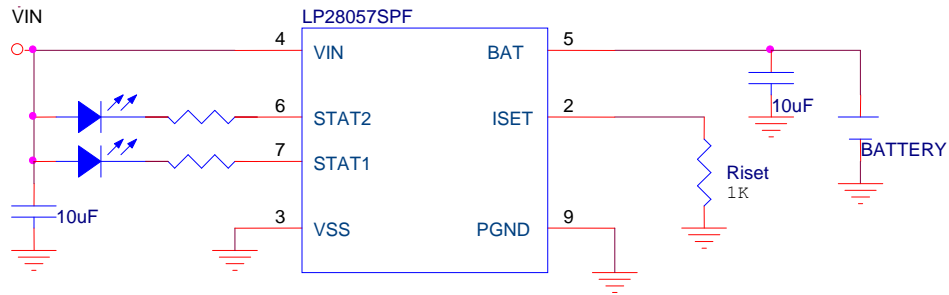

## Functional Pin Description

Package Type	Pin Configurations
ESOP-8	

## Pin Description

Pin	Name	Description
1	NC	No Connector.
2	ISET	Charge Current Program, Charge Current Monitor and Shutdown Pin.
3	VSS	VSS is the connection to system ground.
4	VIN	VIN is the input power source. Connect to a wall adapter.
5	BAT	BAT is the connection to the battery. Typically a 10 $\mu$ F Tantalum capacitor is needed for stability when there is no battery attached. When a battery is attached, only a 0.1 $\mu$ F ceramic capacitor is required.
6	STAT2	Open-Drain Charge Status Output. When the battery is charging, the STAT pin could be pulled High by an external pull high resistor. When the charge cycle is completed, the pin is pulled Low by an internal N-channel MOSFET.
7	STAT1	Open-Drain Charge Status Output. When the battery is charging, the STAT pin is pulled low by an internal N-channel MOSFET. When the charge cycle is completed, the pin could be pulled High by an external pull high resistor.
8	NC	No Connector.
9	PGND	Ground.



### Function Block Diagram

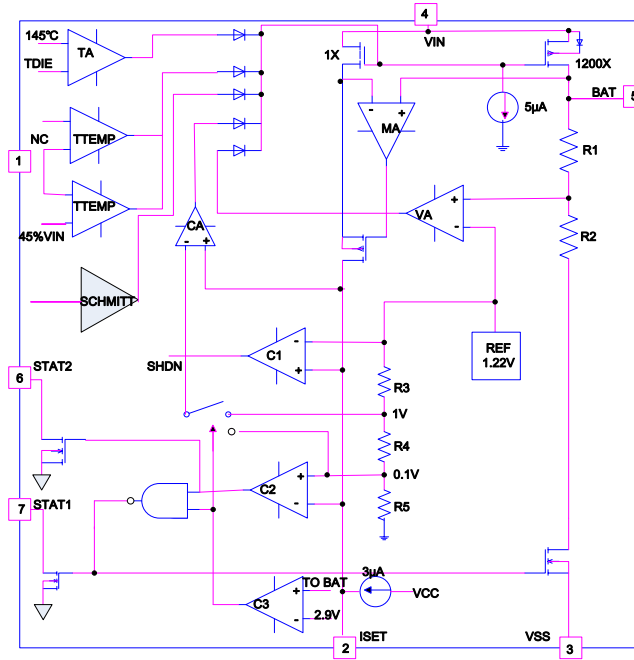

### Absolute Maximum Ratings Note 1

- ✧ Input to GND(VIN) ----- -0.3V to 8V
- ✧ BAT to GND ----- -5V to 8V
- ✧ VIN to BAT ----- 8V
- ✧ Other Pin to GND ----- -0.3V to 6V
- ✧ BAT Short-circuit Duration ----- Continuous
- ✧ Maximum Junction Temperature ----- 150°C
- ✧ Storage Temperature ----- -45°C to 165°C
- ✧ Operating Ambient Temperature Range (TA) ----- -40°C to 85°C
- ✧ Maximum Soldering Temperature (at leads, 10 sec) ----- 260°C

**Note 1.** Stresses beyond those listed under "Absolute Maximum Ratings" may cause permanent damage to the device. These are stress ratings only, and functional operation of the device at these or any other conditions beyond those indicated in the operational sections of the specifications is not implied. Exposure to absolute maximum rating conditions for extended periods may affect device reliability.

### Thermal Information

- ✧ Maximum Power Dissipation (  $P_D, T_A=25^\circ\text{C}$  ) ----- 2W
- ✧ Thermal Resistance ( $\theta_{JA}$ ) ----- 50°C/W

### ESD Susceptibility

- ✧ HBM(Human Body Mode) ----- 2KV
- ✧ MM(Machine Mode) ----- 200V



## Electrical Characteristics

( $T_A=25^{\circ}\text{C}$ .  $V_{IN}=5\text{V}$ , unless otherwise noted.)

Symbol	Parameter	Condition	Min	Typ	Max	Units
$V_{IN}$	Adapter/USB Voltage Range		4.5	5	6.5	V
$I_{CC}$	Input Supply Current	Charge Mode, $R_{ISET}=10\text{k}$		300	2000	$\mu\text{A}$
		Standby Mode (Charge Terminated)		300	500	$\mu\text{A}$
		Shutdown Mode ( $R_{ISET}$ NC)			50	$\mu\text{A}$
$V_{FLOAT}$	Regulated Output (Float) Voltage	$I_{BAT}=40\text{mA}$	4.158	4.2	4.242	V
$I_{BAT}$	BAT Pin Current	$R_{ISET}=1\text{k}$	850	1000	1150	mA
		$R_{ISET}=2\text{k}$	430	500	570	mA
		Reverse Current, $V_{BAT}=-4.2\text{V}$		-1		mA
		Standby Mode, $V_{BAT}=4.2\text{V}$	0	0.1	1	$\mu\text{A}$
		Shutdown Mode ( $R_{ISET}$ NC)	0	0.1	1	$\mu\text{A}$
$I_{TRIKL}$	Trickle Charge Current	$V_{BAT}<V_{TRIKL}$		10		$\%I_{BAT}$
$V_{TRIKL}$	Trickle Charge Threshold Voltage	$R_{ISET}=10\text{k}$ , $V_{BAT}$ Rising	2.8	2.9	3.0	V
$V_{TR-HYS}$	Trickle Charge Hysteresis Voltage	$R_{ISET}=10\text{k}$	60	80	110	mV
$V_{UV}$	$V_{IN}$ Under voltage Lockout Threshold	From $V_{IN}$ Low to High	3.7	3.8	3.95	V
$V_{UV-HYS}$	$V_{IN}$ Under voltage Lockout Hysteresis			500		mV
$V_{ASD}$	$V_{IN}$ - $V_{BAT}$ Lockout Threshold Voltage	$V_{IN}$ from Low to High	70	100	140	mV
$V_{ASD-HYS}$	$V_{ASD}$ Hysteresis Voltage			20		mV
$I_{TERM}$	Termination Current Threshold	$R_{ISET}=10\text{k}$		10		$\%I_{BAT}$
		$R_{ISET}=2\text{k}$		10		$\%I_{BAT}$
$V_{ISET}$	ISET Pin Voltage	$R_{ISET}=10\text{k}$ , Current Mode		1		V
$V_{STAT}$	STAT Pin Output Low Voltage	$I_{STAT}=5\text{mA}$		0.35	0.6	V
$I_{STAT}$	STAT Pin Weak Pull-Down Current	$V_{STAT}=5\text{V}$			5	$\mu\text{A}$
$\Delta V_{RECHRG}$	Recharge Battery Threshold Voltage	$V_{FLOAT}-V_{RECHRG}$	100	150	200	mV
$T_{LIM}$	Junction Temperature in Constant Temperature Mode			150		$^{\circ}\text{C}$
$R_{ON}$	Power FET "ON" Resistance (Between $V_{IN}$ and BAT)			300		m $\Omega$

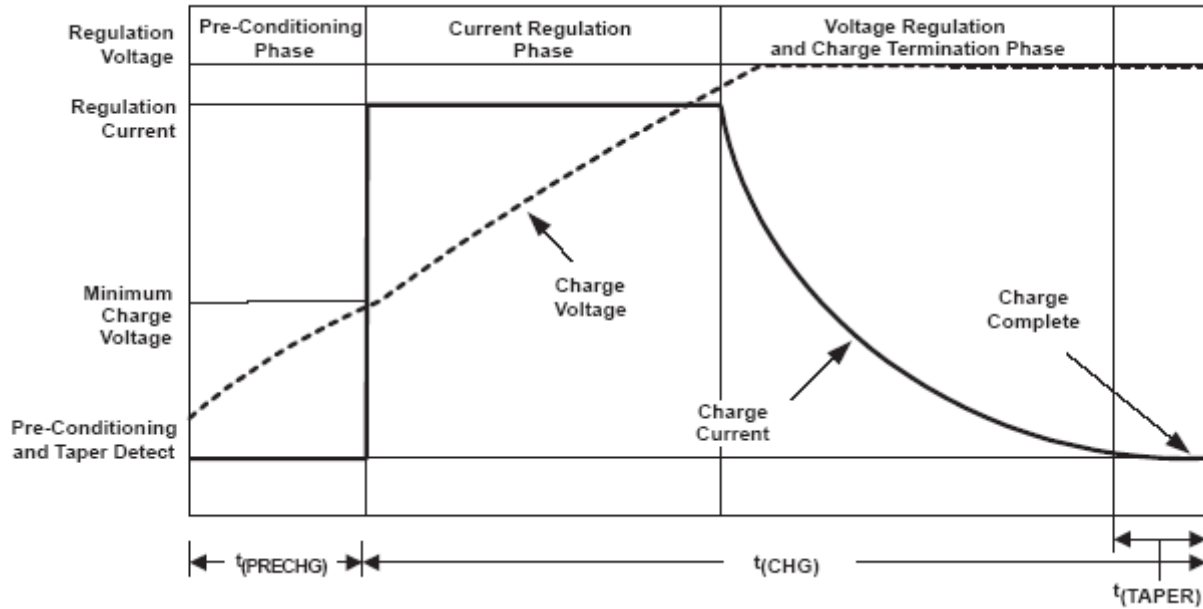



## Application Information

The LP28057 is a single cell lithium-ion battery charger using a constant-current/constant-voltage algorithm. It can deliver up to 1200mA of charge current (using a good thermal PCB layout) with a final float voltage accuracy of ±1%(4.2V). The LP28057 includes an internal P-channel power MOSFET and thermal regulation circuitry. No blocking diode or external current sense resistor is required; thus, the basic charger circuit requires only two external components. Furthermore, the LP28057 is capable of operating from a USB power source.

### Normal Charge Cycle

A charge cycle begins when the voltage at the VIN pin rises above the UVLO threshold level and a 1% ISET ram resistor is connected from the ISET pin to ground or when a battery is connected to the charger output. If the BAT pin is less than 2.9V, the charger enters trickle charge mode. In this mode, the LP28057 supplies approximately 1/10 the R<sub>ISET</sub> programmed charge current. When the BAT pin voltage rises above 2.9V, the charger enters constant-current mode, where the R<sub>ISET</sub> rammed charge current is supplied to the battery. When the BAT pin approaches the final float voltage, the LP28057 enters constant-voltage mode and the charge current begins to decrease. The charge cycle ends when the charge current drops to 1/10 of the R<sub>ISET</sub> rammed value.

### ISET ramming Charge Current

The charge current is R<sub>ISET</sub> rammed using a single resistor from the ISET pin to ground. The battery charge current is 500 times the current out of the ISET pin. The ISET ram resistor and the charge current are calculated using the following equations:

$$R_{ISET}=1000V/I_{BAT} \quad I_{BAT}=1000V/R_{ISET}$$

The charge current out of the BAT pin can be determined at any time by monitoring the ISET pin voltage using the following equation:

$$I_{BAT}=V_{ISET} \times 1000/R_{ISET}$$

### Charge Termination

A charge cycle is terminated when the charge current falls to 1/10th the ISET rammed value after the final float voltage is reached. This condition is detected by using an internal, filtered comparator to monitor the ISET pin. When the ISET pin voltage falls below 200mV for longer than t<sub>TERM</sub>(typically 1ms), charging is terminated. The charge current is latched off and the LP28056S enters standby mode, where the input supply current drops to 200µA. In this state, all loads on the BAT pin must be supplied by the battery. (Note: C/10 termination is disabled in trickle charging and thermal limiting modes).

### Charge Status Indicator (STAT)

The charge status output has two different states: strong pull-down (~5mA) and high impedance. The strong pull-down state indicates that the LP28057 is in a charge cycle. Once the charge cycle has terminated, the pin state is determined by under voltage lockout conditions. High impedance indicates that the LP28057 is in under voltage lockout mode: either VIN is less than 100mV above the BAT pin voltage or insufficient voltage is applied to the VIN pin.

A microprocessor can be used to distinguish between these two states—this method is discussed in the Applications Information section.

Function	STAT1(pin7)	STAT2(pin6)
Charging	Low	High
Charge Complete	High	Low

### Thermal Limiting

An internal thermal feedback loop reduces the I<sub>SET</sub> rammed charge current if the die temperature attempts to rise above a preset value of approximately 150°C. This feature protects the LP28057 from excessive temperature and allows the user to push the limits of the power handling capability of a given circuit board without risk of damaging the LP28057.

The charge current can be set according to typical (not worst-case) ambient temperature with the assurance that the charger will automatically reduce the current in worst-case conditions.



### Under voltage Lockout (UVLO)

An internal under voltage lockout circuit monitors the input voltage and keeps the charger in shutdown mode until  $V_{IN}$  rises above the under voltage lockout threshold. The UVLO circuit has a built-in hysteresis of 200mV. Furthermore, to protect against reverse current in the power MOSFET, the UVLO circuit keeps the charger in shutdown mode if  $V_{IN}$  falls to within 80mV of the battery voltage. If the UVLO comparator is tripped, the charger will not come out of shutdown mode until  $V_{IN}$  rises to 100mV above the battery voltage.

### Power Dissipation

The conditions that cause the LP28057 to reduce charge current through thermal feedback can be approximated by considering the power dissipated in the IC. Nearly all of this power dissipation is generated by the internal MOSFET this is calculated to be approximately:

$$P_D = (V_{IN} - V_{BAT}) \times I_{BAT}$$

Where  $P_D$  is the power dissipated,  $V_{IN}$  is the input supply voltage,  $V_{BAT}$  is the battery voltage and  $I_{BAT}$  is the charge current. The approximate ambient temperature at which the thermal feedback begins to protect the IC is:

$$T_A = 150^\circ\text{C} - P_D \times \theta_{JA}$$

$$T_A = 150^\circ\text{C} - (V_{IN} - V_{BAT}) \times I_{BAT} \times \theta_{JA}$$





### Packaging Information

### ESOP-8

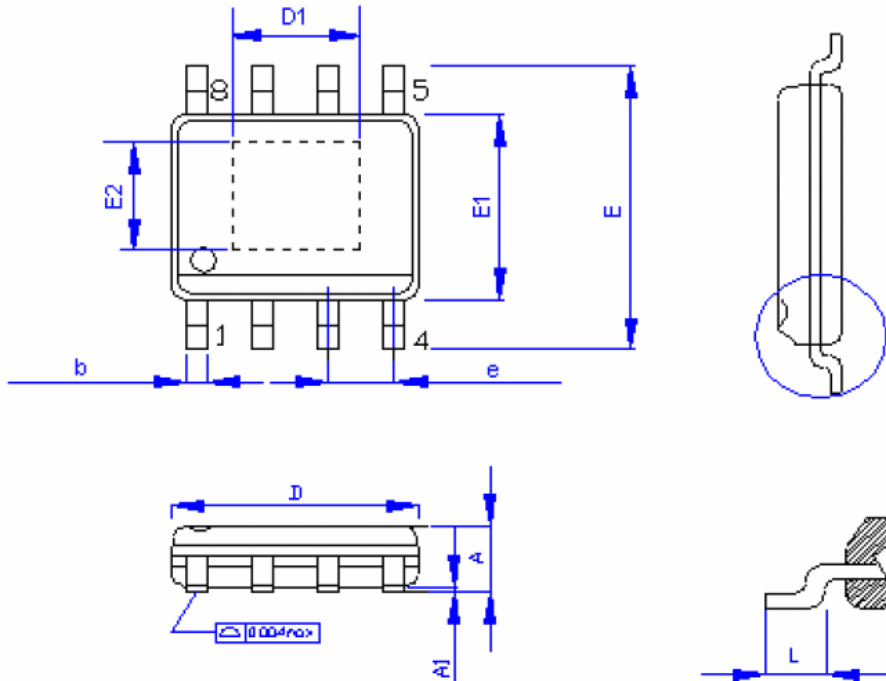

SYMBOLS	MILLIMETERS		INCHES	
	MIN.	MAX.	MIN.	MAX.
A	1.35	1.75	0.053	0.069
A1	0.05	0.25	0.002	0.010
D	4.90		0.193	
E1	3.90		0.153	
E	5.80	6.20	0.228	0.244
L	0.40	1.27	0.016	0.050
b	0.33	0.51	0.013	0.020
e	1.27		0.500	
D1	2.06		0.081	
E2	2.06		0.081	



## X-ON Electronics

Largest Supplier of Electrical and Electronic Components

*Click to view similar products for [Battery Management](#) category:*

*Click to view products by [LOWPOWER](#) manufacturer:*

Other Similar products are found below :

[MP2602DQ-LF-P](#) [MP26053DQ-LF-Z](#) [MP2611GL-P](#) [NCP347MTAHTBG](#) [LM3658SD-AEV/NOPB](#) [MP2607DL-LF-P](#) [MP26121DQ-LF-P](#)  
[MP26123DR-LF-P](#) [MP2633GR-P](#) [MP2637GR-P](#) [BQ24212EVM-678](#) [NCP1855FCCT1G](#) [MP2636GR-P](#) [FAN54063UCX](#)  
[MAX14680EWC+T](#) [MAX14634EWC+T](#) [DS2745U+T&R](#) [MAX14578EETE+T](#) [DS2781EVKIT+](#) [DS2781E+T&R](#) [MP2605DQ-LF-P](#)  
[DS2710G+T&R](#) [MAX17040G+T](#) [MAX14525ETA+T](#) [MP2615GQ-P](#) [MAX14578EEWC+T](#) [LC05132C01NMTTGTG](#) [MAX8971EWP+T](#)  
[MAX14630EZK+T](#) [MAX1873TEEE+T](#) [PSC5415A](#) [AUR9811DGD](#) [SN2040DSQR](#) [DS2715BZ+T&R](#) [MAX1508ZETA+T](#)  
[MAX14921ECS+T](#) [MAX77301EWA+T](#) [BD8668GW-E2](#) [MAX16024PTBS+T](#) [DS2715Z+T&R](#) [MAX16024LTBZ18+T](#) [DS2782E+T&R](#)  
[DS2782G+T&R](#) [MAX1908ETI+T](#) [ISL95522IRZ](#) [ISL95522HRZ](#) [ARD00558](#) [NCP4371AAEDR2G](#) [BD8665GW-E2](#) [MAX8934EETI+T](#)