

Features

- 7A,650V, $R_{DS(on)}$ (TYP:1.0 Ω)@ $V_{GS}=10V$
- Ultra-low Gate Charge(Typical 21nC)
- Fast Switching Capability
- 100%Avalanche Tested
- Improved dv/dt capability

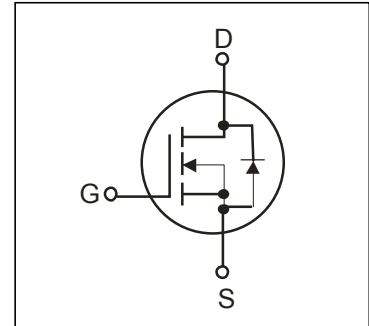

General Description

This Power MOSFET is produced using advanced planar stripe,VDMOS technology. This technology has been especially designed to minimize on-state resistance,have a high rugged avalanche characteristics. This devices is specially well suited for high efficiency switch mode power supplies , power factor correction, UPS and a electronic lamp ballast base on half bridge.

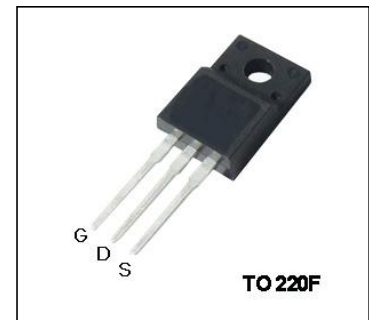

Absolute Maximum Ratings

| Symbol | Parameter | Value | Units |
|----------------|---|----------|-------------|
| V_{DSS} | Drain Source Voltage | 650 | V |
| I_D | Continuous Drain Current(@ $T_c=25^{\circ}C$) | 7 | A |
| | Continuous Drain Current(@ $T_c=100^{\circ}C$) | 3.2 | A |
| I_{DM} | Drain Current Pulsed (Note1) | 28 | A |
| V_{GS} | Gate to Source Voltage | ± 30 | V |
| E_{AS} | Single Pulsed Avalanche Energy (Note2) | 232 | mJ |
| E_{AR} | Repetitive Avalanche Energy (Note1) | 12 | mJ |
| I_{AR} | Avalanche Current (Note1) | 7.5 | A |
| dv/dt | Peak Diode Recovery dv /dt (Note3) | 10 | V/ ns |
| P_D | Total Power Dissipation(@ $T_c=25^{\circ}C$) | 40 | W |
| T_J, T_{stg} | Junction and Storage Temperature | -55~150 | $^{\circ}C$ |
| T_L | Channel Temperature | 300 | $^{\circ}C$ |

*Drain current limited by maximum junction temperature

Thermal Characteristics

| Symbol | Parameter | Value | | | Units |
|-----------|---|-------|-----|------|---------------|
| | | Min | Typ | Max | |
| R_{QJC} | Thermal Resistance , Junction -to -Case | - | - | 3.1 | $^{\circ}C/W$ |
| R_{QJA} | Thermal Resistance , Junction-to -Ambient | - | - | 62.5 | $^{\circ}C/W$ |

Electrical Characteristics(Tc=25°C)

| Characteristics | | Symbol | Test Condition | Min | Type | Max | Unit |
|--|---------------------|-------------------------------------|---|-----|------|------|------|
| Gate leakage current | | I _{GSS} | V _{GS} =±30V,V _{DS} =0V | - | - | ±100 | nA |
| Gate-source breakdown voltage | | V _{(BR)GSS} | I _G =±10 μA,V _{DS} =0V | ±30 | - | - | V |
| Breakdown voltage Temperature Coefficient | | ΔBV _{DSS} /ΔT _J | I _D =250μA,Referenced to 25°C | - | 0.8 | - | V/°C |
| Drain cut -off current | | I _{DSS} | V _{DS} =650V,V _{GS} =0V | - | - | 10 | μA |
| | | | V _{DS} =520V, T _C =125°C | | | 100 | |
| Drain -source breakdown voltage | | V _{(BR)DSS} | I _D =250 μA,V _{GS} =0V | 650 | - | - | V |
| Gate threshold voltage | | V _{GS(th)} | V _{DS} = V _{GS} ,I _D =250 μA | 2 | - | 4 | V |
| Drain -source ON resistance | | R _{DS(ON)} | V _{GS} =10V,I _D =3.5A | - | 1.0 | 1.45 | Ω |
| Forward Transconductance | | g _{fs} | V _{DS} =40V,I _D =7A | - | 3 | - | S |
| Input capacitance | | C _{iss} | V _{DS} =25V, | - | 1052 | - | pF |
| Reverse transfer capacitance | | C _{rss} | V _{GS} =0V, | - | 12 | - | |
| Output capacitance | | C _{oss} | f=1MHz | - | 85 | - | |
| Switching time | Turn-On rise time | t _r | V _{DD} =300V, | - | 34 | - | ns |
| | Turn-On delay time | t _{d(on)} | I _D =7A, | - | 12 | - | |
| | Turn-Off Fall time | t _f | R _G =25Ω, | - | 41 | - | |
| | Turn-Off delay time | t _{d(off)} | (Note4,5) | - | 46 | - | |
| Total gate charge(gate-source plus gate-drain) | | Q _g | V _{DD} =480V, V _{GS} =10V, | - | 21 | - | nC |
| Gate-source charge | | Q _{gs} | I _D =7.5A | - | 4.9 | - | |
| Gate-drain("miller") Charge | | Q _{gd} | (Note4,5) | - | 6.6 | - | |

Source-Drain Ratings and Characteristics(Ta=25°C)

| Characteristics | Symbol | Test Condition | Min | Type | Max | Unit |
|----------------------------------|------------------|--|-----|------|-----|------|
| Continuous drain reverse current | I _{DR} | - | - | - | 7.5 | A |
| Pulse drain reverse current | I _{DRP} | - | - | - | 40 | A |
| Forward voltage(diode) | V _{DSF} | I _{DR} =7A,V _{GS} =0V | - | - | 1.4 | V |
| Reverse recovery time | t _{rr} | I _{DR} =7A,V _{GS} =0V, | - | 366 | - | ns |
| Reverse recovery charge | Q _{rr} | dI _{DR} / dt =100 A / μs | - | 3.5 | - | μC |

Note 1.Repeativity rating :pulse width limited by junction temperature

2.L=10mH I_{AS}=7.5A,V_{DD}=50V,R_G=25Ω ,Starting T_J=25°C

3.I_{SD}≤10A,di/dt≤300A/us,V_{DD}<BV_{DSS},STARTING T_J=25°C

4.Pulse Test:Pulse Width≤300us,Duty Cycle≤2%

5. Essentially independent of operating temperature.

This transistor is an electrostatic sensitive device

Please handle with caution

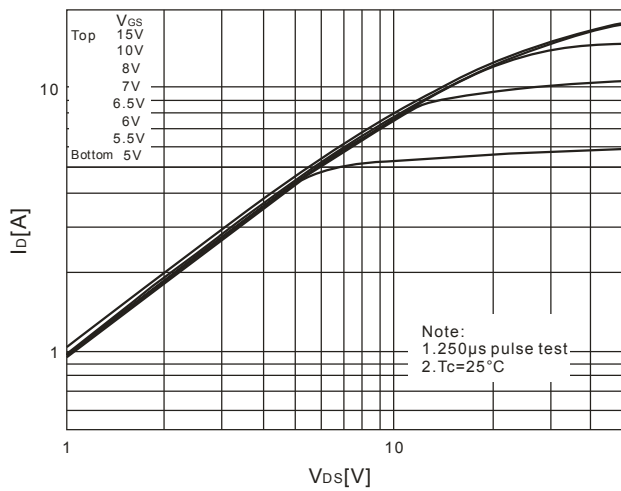

Fig.1 On-Region Characteristics

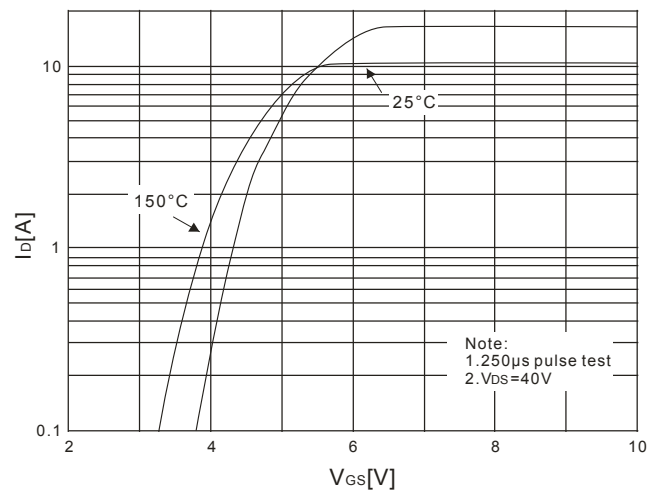

Fig.2 Transfer characteristics

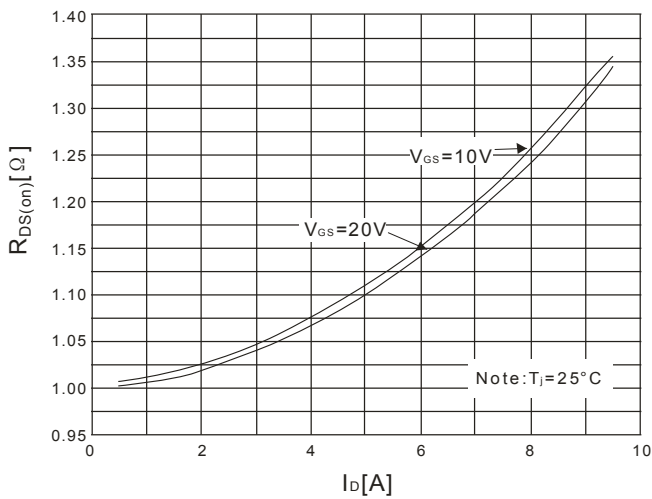

Fig.3 On-Resistance variation vs Drain Current and Gate Voltage

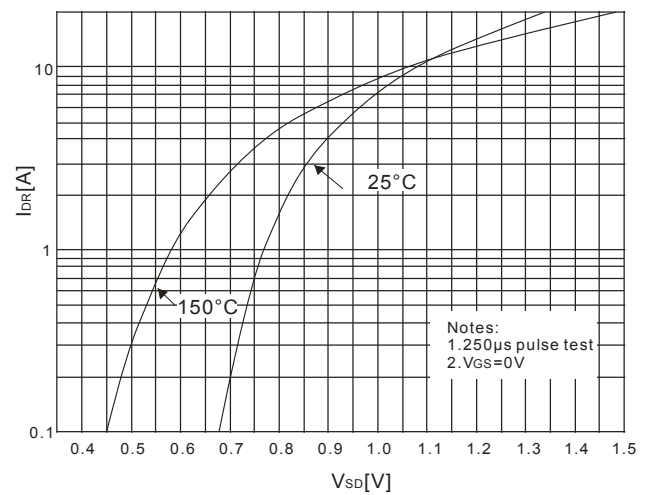

Fig.4 Body Diode Forward Voltage Variation with Source Current and Temperature

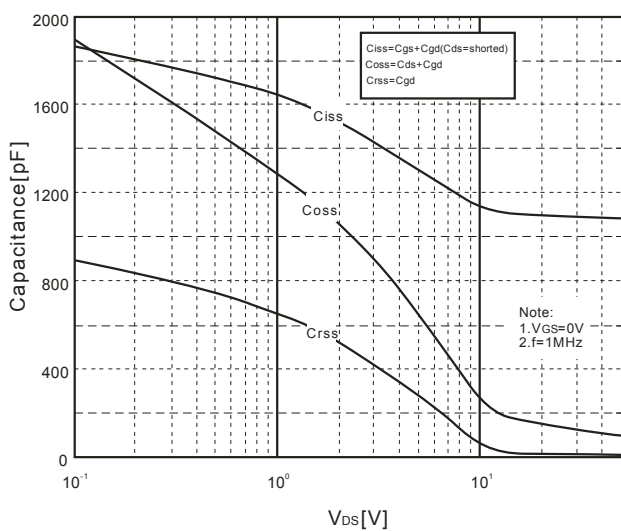

Fig.5 Capacitance Characteristics

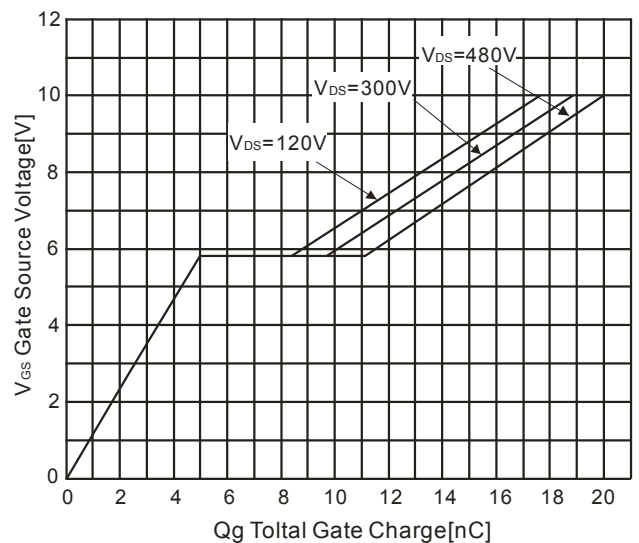

Fig.6 Gate Charge Characteristics

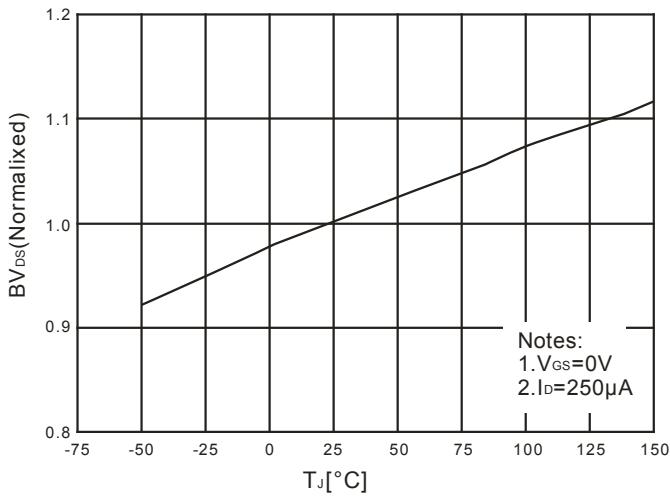

Fig.7 Breakdown Voltage Variation vs. Temperature

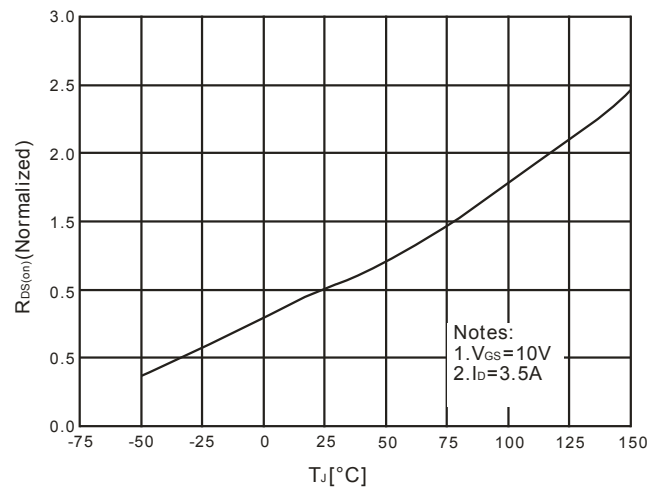

Fig.8 On-Resistance Variation vs. Temperature

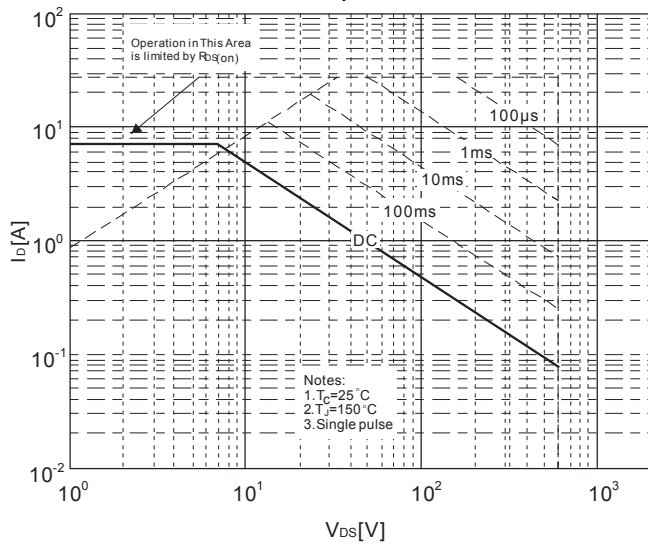

Fig.9 Maximum Safe Operation Area

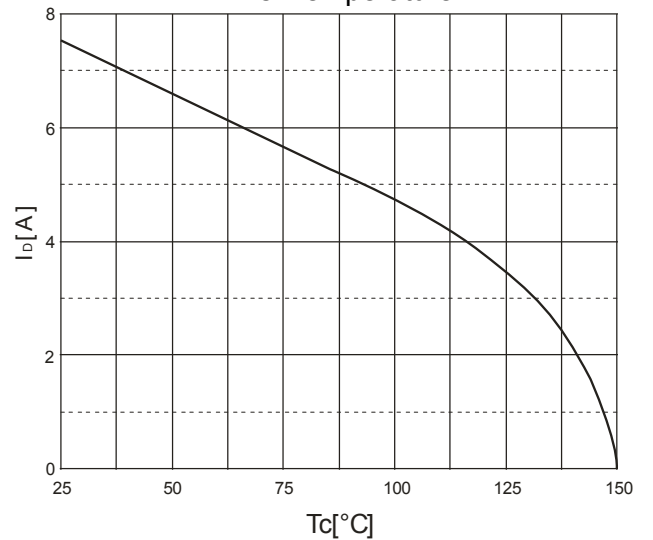

Fig.10 Maximum Drain Current vs Case Temperature

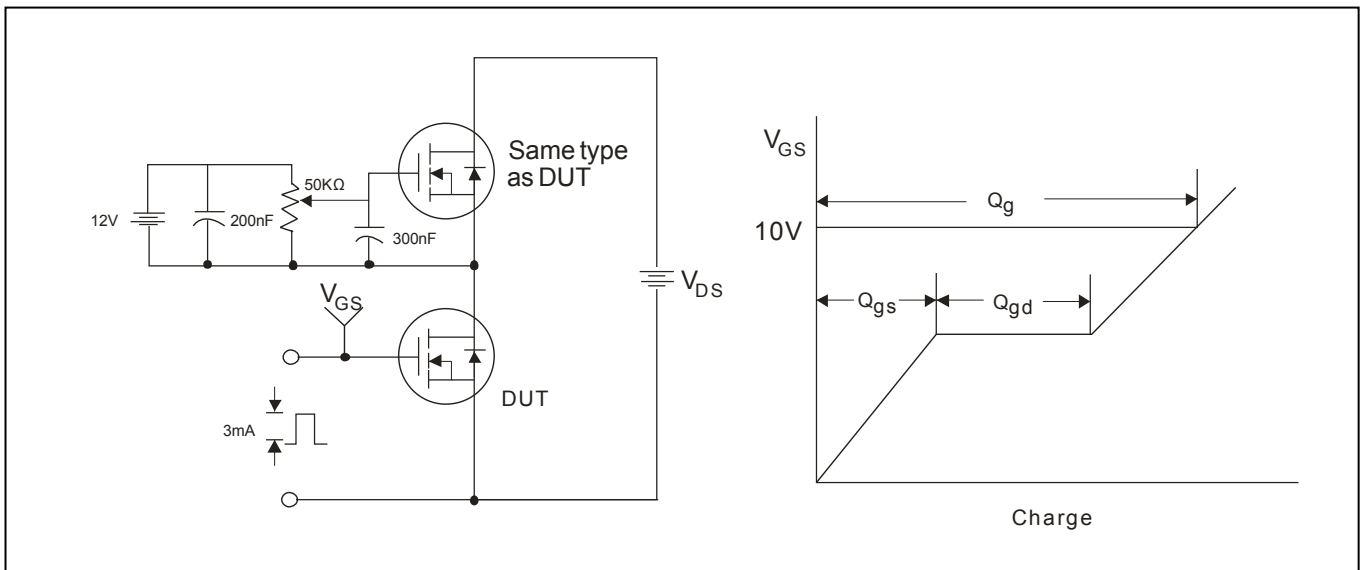

Fig.11 Gate Test circuit & Waveform

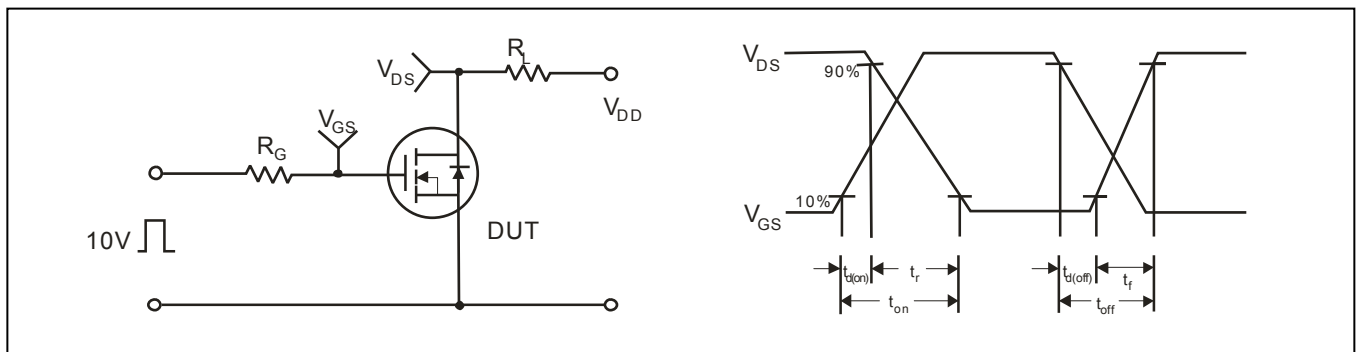

Fig.12 Resistive Switching Test Circuit & Waveform

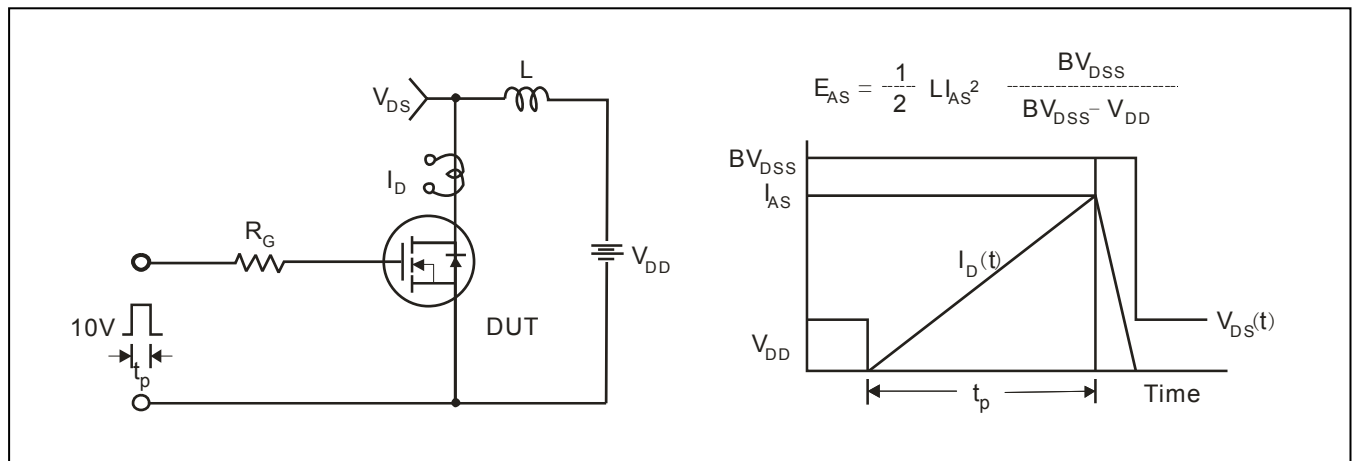

Fig.13 Uncamped Inductive Switching Test Circuit & Waveform

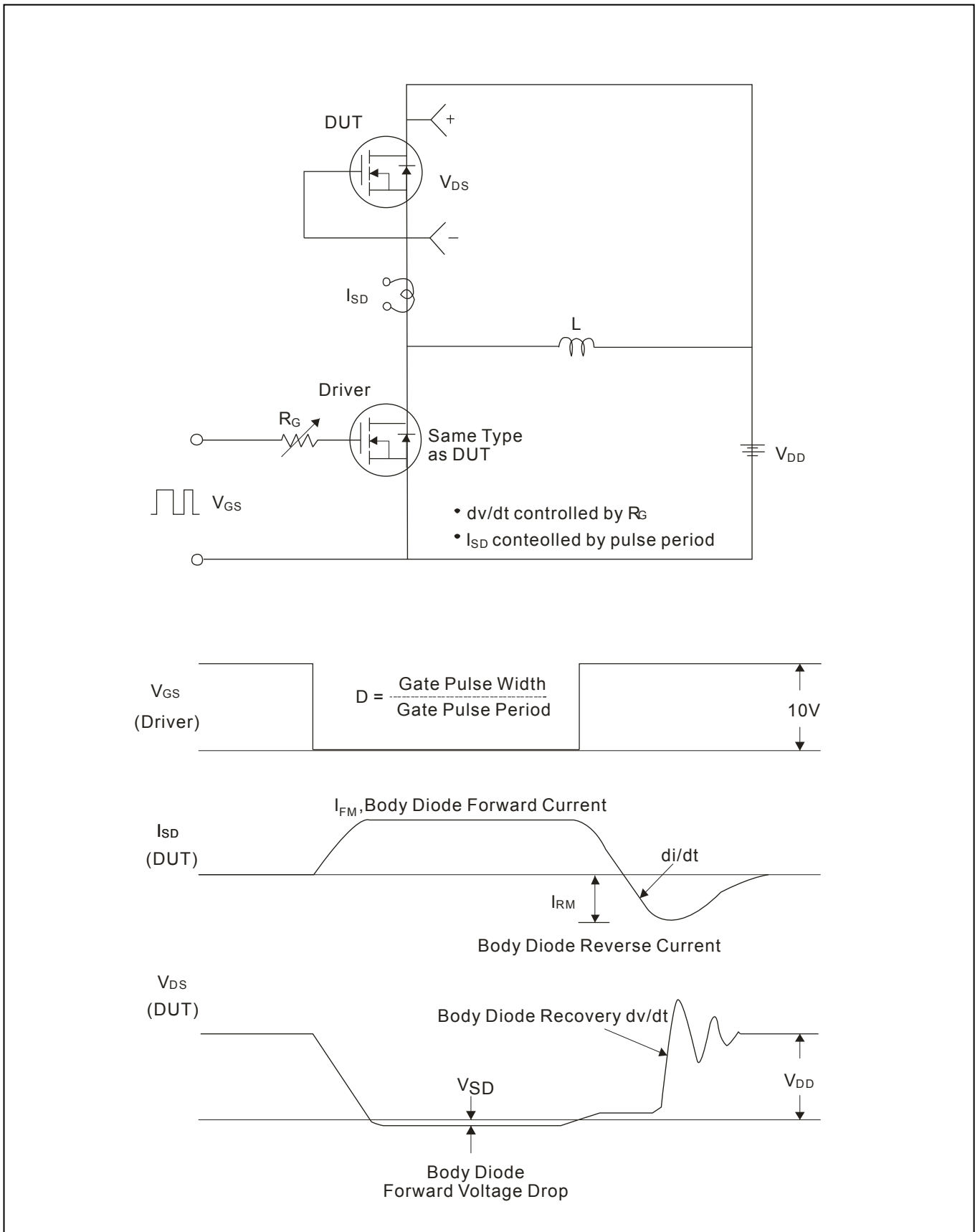
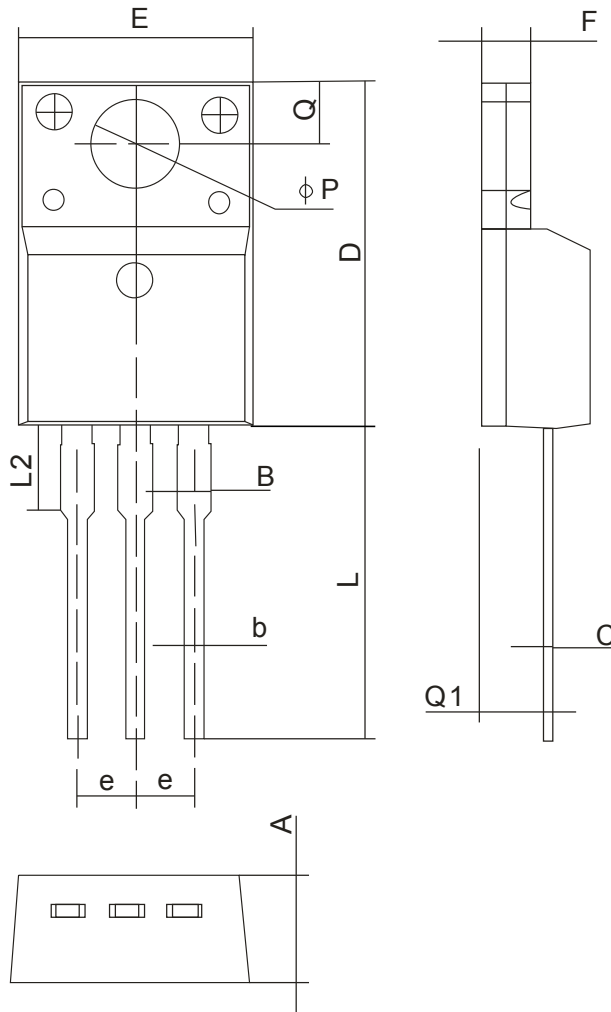

Fig.15 Peak Diode Recovery dv/dt Test Circuit & Waveform

TO-220F Package Dimension

Unit:mm



| 符号 Symbol | MIN | MAX |
|--------------|----------|-------|
| A | 4.5 | 4.9 |
| B | - | 1.47 |
| b | 0.7 | 0.9 |
| c | 0.45 | 0.6 |
| D | 15.67 | 16.07 |
| E | 9.96 | 10.36 |
| e | 2.54TYPE | |
| F | 2.34 | 2.74 |
| L | 12.58 | 13.38 |
| L2 | 3.13 | 3.33 |
| ΦP | 3.08 | 3.28 |
| Q | 3.2 | 3.4 |
| Q1 | 2.56 | 2.96 |

NOTE:

- 1.We strongly recommend customers check carefully on the trademark when buying our product, if there is any question, please don't be hesitate to contact us.
- 2.Please do not exceed the absolute maximum ratings of the device when circuit designing.
- 3.Winsemi Microelectronics Co., Ltd reserved the right to make changes in this specification sheet and is subject to change without prior notice.

CONTACT:

Winsemi Microelectronics Co., Ltd.

ADD:Room 1002, East, Phase 2, HighTech Plaza,Tian-An Cyber Park,Che gong miao, FuTian, Shenzhen, P.R. China.

Post Code : 518040

Tel : +86-755-8250 6288

FAX : +86-755-8250 6299

Web Site : www.winsemi.com

X-ON Electronics

Largest Supplier of Electrical and Electronic Components

Click to view similar products for [MOSFET](#) category:

Click to view products by [Winsemi](#) manufacturer:

Other Similar products are found below :

[614233C](#) [648584F](#) [MCH3443-TL-E](#) [MCH6422-TL-E](#) [FDPF9N50NZ](#) [FW216A-TL-2W](#) [FW231A-TL-E](#) [APT5010JVR](#) [NTNS3A92PZT5G](#)
[IRF100S201](#) [JANTX2N5237](#) [2SK2464-TL-E](#) [2SK3818-DL-E](#) [FCA20N60_F109](#) [FDZ595PZ](#) [STD6600NT4G](#) [FSS804-TL-E](#) [2SJ277-DL-E](#)
[2SK1691-DL-E](#) [2SK2545\(Q,T\)](#) [D2294UK](#) [405094E](#) [423220D](#) [MCH6646-TL-E](#) [TPCC8103,L1Q\(CM](#) [367-8430-0972-503](#) [VN1206L](#)
[424134F](#) [026935X](#) [051075F](#) [SBVS138LT1G](#) [614234A](#) [715780A](#) [NTNS3166NZT5G](#) [751625C](#) [873612G](#) [IRF7380TRHR](#)
[IPS70R2K0CEAKMA1](#) [RJK60S3DPP-E0#T2](#) [RJK60S5DPK-M0#T0](#) [APT5010JVFR](#) [APT12031JFLL](#) [APT12040JVR](#) [DMN3404LQ-7](#)
[NTE6400](#) [JANTX2N6796U](#) [JANTX2N6784U](#) [JANTXV2N5416U4](#) [SQM110N05-06L-GE3](#) [SIHF35N60E-GE3](#)