



Features

- ESD Protect for 1 Line with Bi-directional
- Provide ESD protection for the protected line to IEC 61000-4-2 (ESD) $\pm 20\text{kV}$ (air), $\pm 20\text{kV}$ (contact)
IEC 61000-4-4 (EFT) 50A (5/50ns)
IEC 61000-4-5 (Lightning) 3A (8/20 μs)
Cable Discharge Event (CDE)
- **0201 small DFN package** saves board space
- Protect one I/O line or one power line
- Fast turn-on and Low clamping voltage
- For operating voltage of **12V and below**
- Solid-state silicon-avalanche and active circuit triggering technology
- Green Part

Applications

- Mobile Phones
- Hand Held Portable Applications
- Computer Interfaces Protection
- Microprocessors Protection
- Serial and Parallel Ports Protection
- Control Signal Lines Protection
- Power lines on PCB Protection
- Latchup Protection

Description

AZ4A12-01F is a design which includes one Bi-directional ESD rated clamping cell to protect one power line, or one control line, or one low speed data line in an electronic systems. The AZ4A12-01F has been specifically designed to protect sensitive components which are connected to power and control lines from over-voltage damage and latch-up caused by Electrostatic Discharging (ESD), Electrical Fast Transients (EFT), and Cable Discharge Event (CDE).

AZ4A12-01F is a unique design which includes proprietary clamping cell in a single package. During transient conditions, the proprietary clamping cell prevents over-voltage on the power line or control/data lines, protecting any downstream components.

AZ4A12-01F may be used to meet the ESD immunity requirements of IEC 61000-4-2, Level 4 ($\pm 15\text{kV}$ air, $\pm 8\text{kV}$ contact discharge)

Circuit Diagram / Pin Configuration

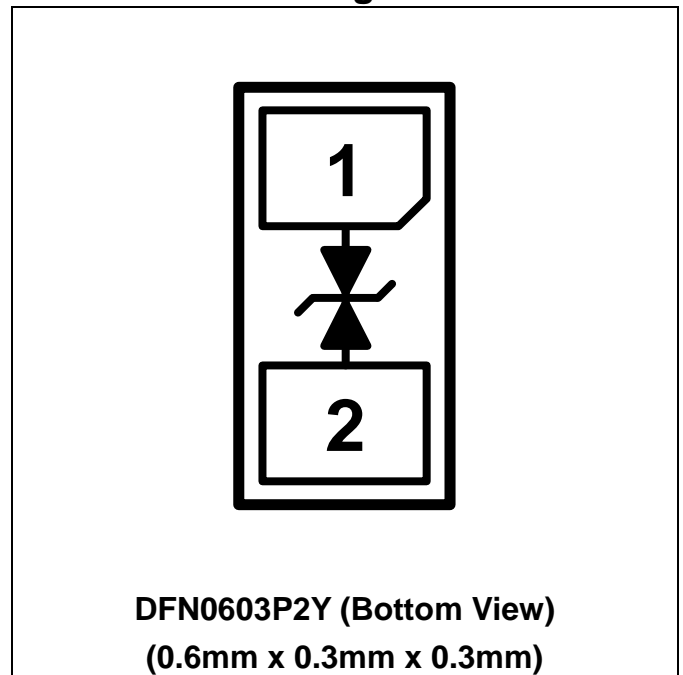



SPECIFICATIONS

ABSOLUTE MAXIMUM RATINGS			
PARAMETER	SYMBOL	RATING	UNITS
Peak Pulse Current (tp=8/20μs)	I _{PP}	3	A
Operating Supply Voltage	V _{DC}	±13.2	V
ESD per IEC 61000-4-2 (Air)	V _{ESD}	±20	kV
ESD per IEC 61000-4-2 (Contact)		±20	
Lead Soldering Temperature	T _{SOL}	260 (10 sec.)	°C
Operating Temperature	T _{OP}	-55 to +85	°C
Storage Temperature	T _{STO}	-55 to +150	°C

ELECTRICAL CHARACTERISTICS						
PARAMETER	SYMBOL	CONDITIONS	MINI	TYP	MAX	UNITS
Stand-Off Voltage	V _{RWM}	T=25 °C.	-12		12	V
Leakage Current	I _{Leak}	V _{RWM} = ±12V, T=25 °C.			0.1	μA
Breakdown Voltage	V _{BV}	I _{BV} = 1mA, T=25 °C.	13.5		16	V
ESD Clamping Voltage (Note 1)	V _{ESD_CL}	IEC 61000-4-2 +8kV (I _{TLP} = 16A), T=25 °C, Contact mode.		18		V
ESD Dynamic Turn-on Resistance	R _{dynamic}	IEC 61000-4-2, 0~+8kV, T=25 °C, Contact mode.		0.3		Ω
Channel Input Capacitance	C _{IN}	V _R = 0V, f = 1MHz, T=25 °C.		3.5	5	pF

Note 1: ESD Clamping Voltage was measured by Transmission Line Pulsing (TLP) System.

TLP conditions: Z₀= 50Ω, t_p= 100ns, t_r= 1ns.



Typical Characteristics

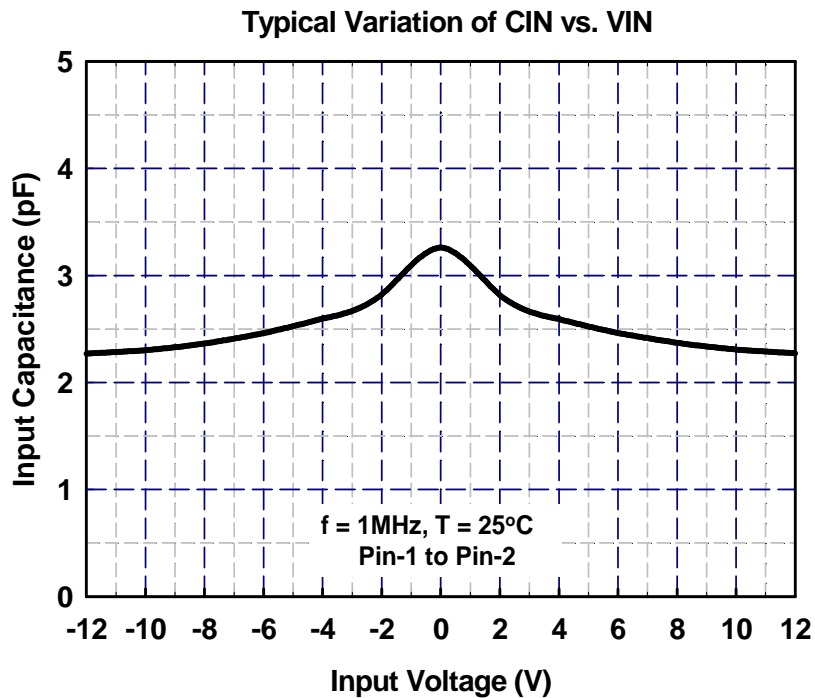
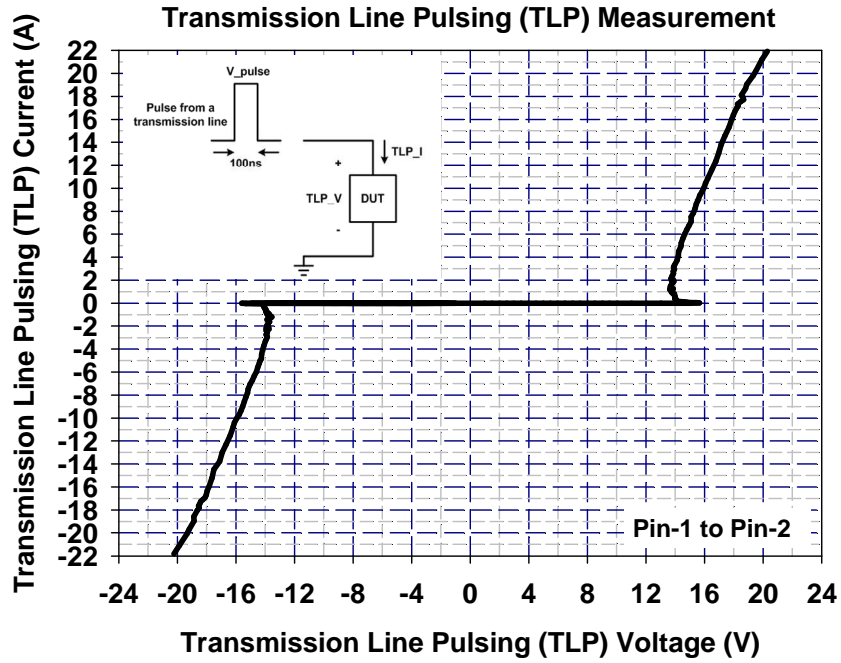



Applications Information

The AZ4A12-01F is designed to protect one line against System ESD/EFT/Cable-Discharge pulses by clamping it to an acceptable reference. It provides bi-directional protection.

The usage of the AZ4A12-01F is shown in Fig. 1. Protected line, such as data line, control line, or power line, is connected at pin 1. The pin 2 is connected to a ground plane on the board. In order to minimize parasitic inductance in the board traces, all path lengths connected to the pins of AZ4A12-01F should be kept as short as possible.

In order to obtain enough suppression of ESD induced transient, good circuit board is critical. Thus, the following guidelines are recommended:

- Minimize the path length between the protected lines and the AZ4A12-01F.
- Place the AZ4A12-01F near the input terminals or connectors to restrict transient coupling.
- The ESD current return path to ground should be kept as short as possible.
- Use ground planes whenever possible.
- NEVER route critical signals near board edges and near the lines which the ESD transient easily injects to.

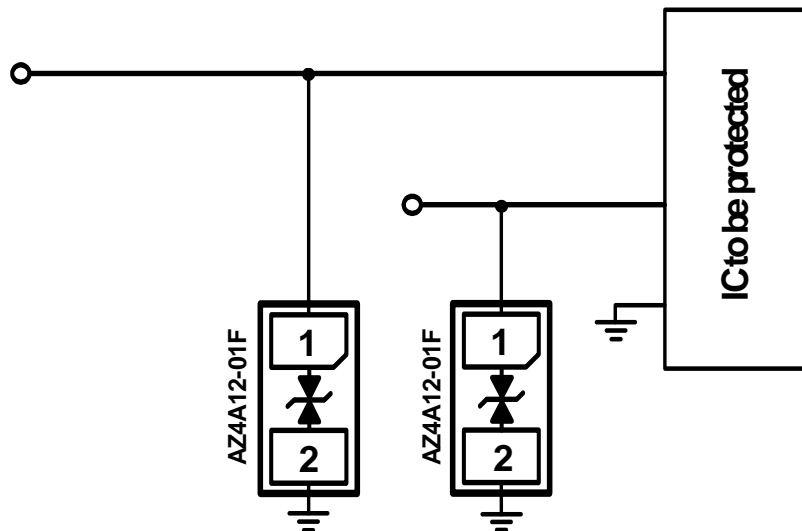
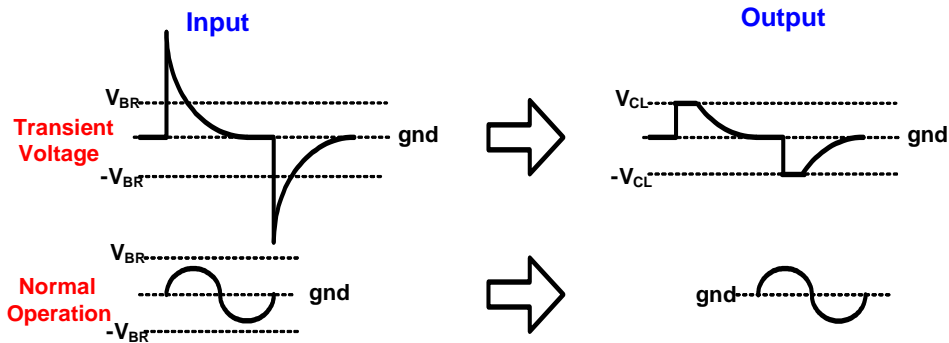

Fig. 1



Fig. 2 shows another simplified example of using AZ4A12-01F to protect the control line, low speed data line, and power line from ESD transient stress.

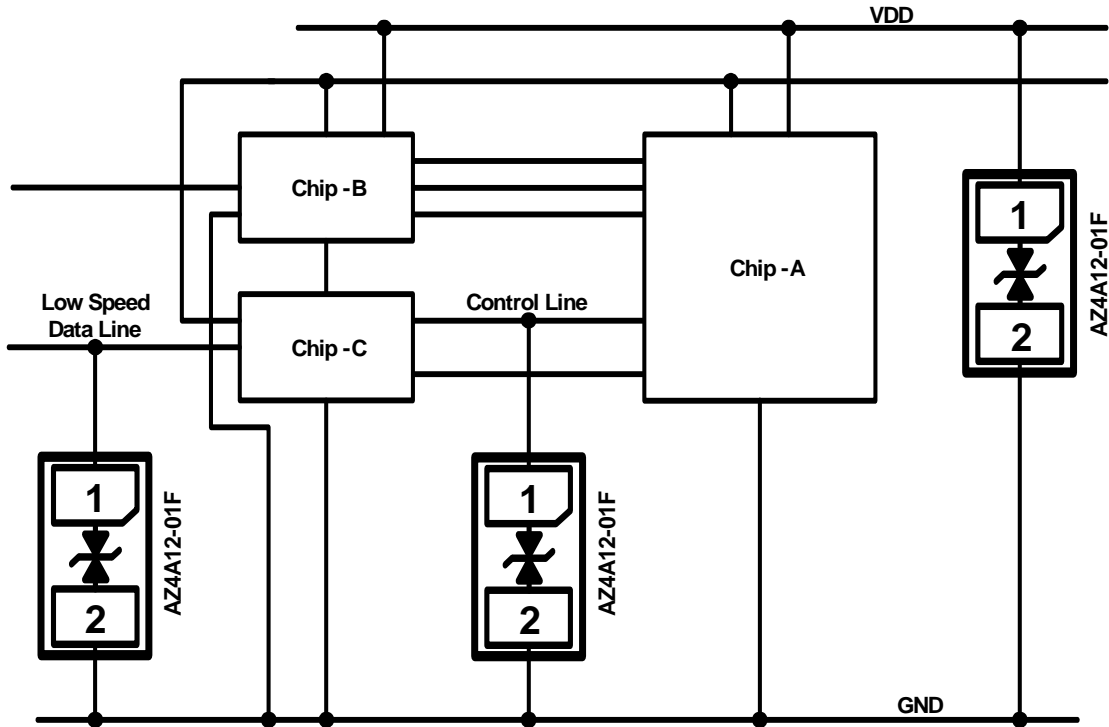
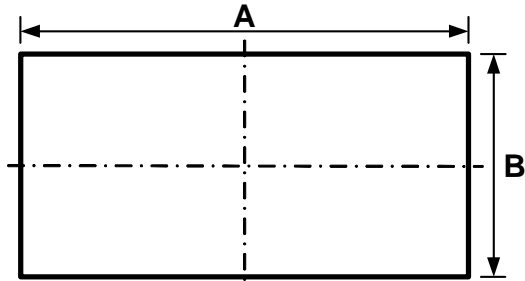

Fig. 2



Mechanical Details

DFN0603P2Y PACKAGE DIAGRAMS



TOP VIEW

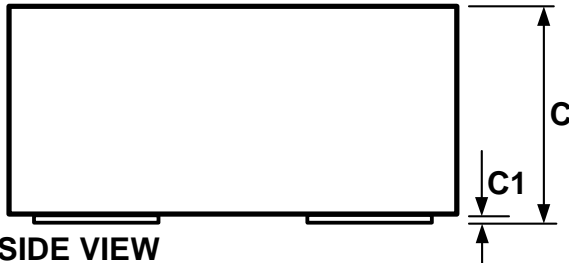

SIDE VIEW

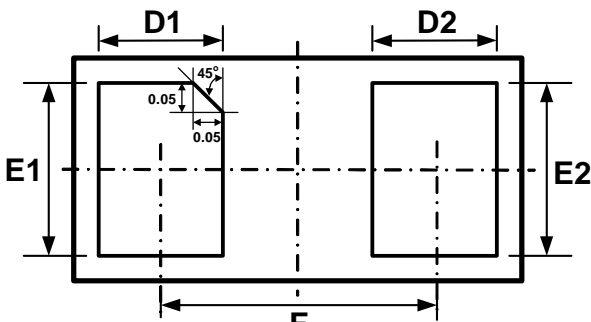

BOTTOM VIEW

SYMBOL	Millimeters		
	MIN.	NOM.	MAX.
A	0.55	0.60	0.65
B	0.25	0.30	0.35
C	0.28	0.30	0.32
C1	0.00	0.02	0.05
D1	0.13	0.18	0.23
D2	0.14	0.19	0.24
E1/E2	0.20	0.25	0.30
F	0.35		

LAND LAYOUT

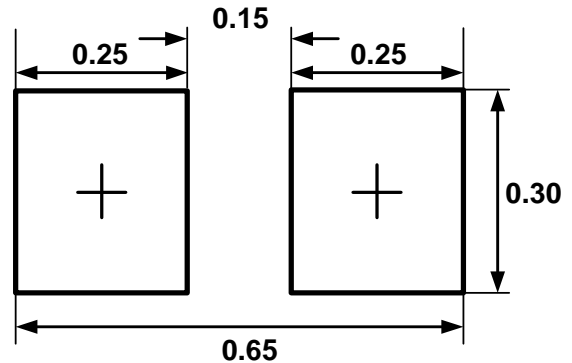

(Unit: mm)

Notes:

This LAND LAYOUT is for reference purposes only. Please consult your manufacturing partners to ensure your company's PCB design guidelines are met.

MARKING CODE

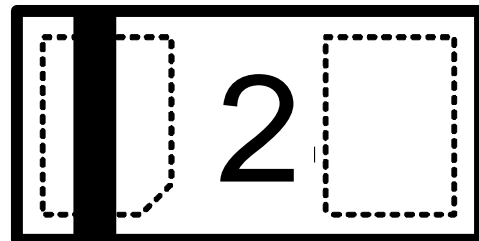

Part Number	Marking Code
AZ4A12-01F (Green Part)	2

Note : Green means Pb-free, RoHS, and Halogen free compliant.



Ordering Information

PN#	Material	Type	Reel size	MOQ	MOQ/internal box	MOQ/carton
AZ4A12-01F.R7G	Green	T/R	7 inch	12,000/reel	4 reel= 48,000/box	6 box =288,000/carton

Revision History

Revision	Modification Description
Revision 2015/05/06	Preliminary Release.
Revision 2016/02/25	Formal Release.

X-ON Electronics

Largest Supplier of Electrical and Electronic Components

Click to view similar products for [ESD Suppressors / TVS Diodes](#) category:

Click to view products by [AMAZING](#) manufacturer:

Other Similar products are found below :

[NTE4902](#) [P4SMAJ15A](#) [P4SMAJ26A](#) [SMAJ400CA-TP](#) [TGL34-47CA](#) [ESDAULC45-1BF4](#) [SM1605E3/TR13](#) [SMF20A-TP](#) [P4SMAJ12A](#)
[CPDUR24V-HF](#) [CPDQC5V0USP-HF](#) [CPDQC5V0-HF](#) [MPLAD30KP45CAE3](#) [MMBZ27VCLQ-7-F](#) [MMAD1108/TR13](#) [MPLAD30KP24A](#)
[ACPDQC5V0R-HF](#) [DFLT170A-7](#) [NTE4900](#) [NTE4926](#) [NTE4938](#) [SMF22A-TP](#) [SMF12A-TP](#) [SLVU2.8-TP](#) [SMLJ6.5CA-TP](#) [SMAJ6.5CA-](#)
[TP](#) [MMAD1108E3/TR13](#) [D5V0M1U2LP3-7](#) [SMAJ400A-TP](#) [AOZ8811DT-03](#) [AOZ8831DI-05](#) [AOZ8831DT-03](#) [SMAJ188CA](#) [3SMC33CA](#)
[BK](#) [CPDQC3V3C-HF](#) [CPDQC12VE-HF](#) [MPLAD30KP170CA](#) [82357120100](#) [5.0SMLJ15CA-TP](#) [5KP18A-TP](#) [P6KE8.2A-TP](#)
[MPLAD30KP43CAE3](#) [SMAJ43A-TP](#) [D5V0F6U8LP33-7](#) [TVS5501V10MUT5G](#) [5.0SMLJ24CA-TP](#) [SMAJ110CA-TP](#) [MPLAD15KP75CAE3](#)
[MMAD1103e3/TR13](#) [DFLT40AQ-7](#)