

## High Sensitivity Hall IC for FAN Driver

### Features

- On-Chip Hall Sensor
- Low Operating Supply Voltage: 2.7V
- High Sensitivity Hall Effect Sensor IC:  $\pm 20G$  (Type.)
- Soft-Switch to Reduce Phase-Switching Noise
- Built-In Output Protection Clamping Circuit
- Lock Protection and Auto Restart Function
- Built-In Thermal Protection Circuit
- 4 Pin TO-92M4 and 5 Pin TSOT-23-5F Packages
- Lead Free and Green Devices Available (RoHS Compliant)

### Pin Description

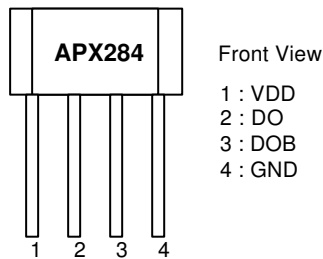

### General Description

The APX284 is an integrated Hall Effect Sensor IC designed for electric commutation of two-phase DC brushless motor applications. The device is built-in lock protection. When the fan is locked, the device will enter the lock protection mode. The APX284 is available in a low cost TO-92M4 package.

### Applications

- Brushless DC Fans
- Brushless DC Motors

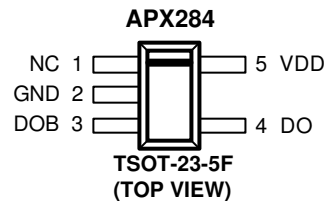

### Ordering and Marking Information

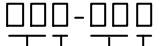
APX284		<ul style="list-style-type: none"> <li>Assembly Material</li> <li>Handling Code</li> <li>Temperature Range</li> <li>Package Code</li> </ul>
		<p>Package Code E : TO-92M4 BE : TSOT-23-5F</p> <p>Temperature Range I : -40 to 105 °C</p> <p>Handling Code PB : Plastic Bag TR : Tape &amp; Reel</p> <p>Assembly Material G : Halogen and Lead Free Device</p>
APX284 E :	<div style="border: 1px solid black; padding: 2px; display: inline-block;">                 APX 284 XXXXX             </div>	XXXXXX - Date Code
APX284 BE :	<div style="border: 1px solid black; padding: 2px; display: inline-block;">                 284X             </div>	The last X is referred to as Date Code.

Note: ANPEC lead-free products contain molding compounds/die attach materials and 100% matte tin plate termination finish; which are fully compliant with RoHS. ANPEC lead-free products meet or exceed the lead-free requirements of IPC/JEDEC J-STD-020D for MSL classification at lead-free peak reflow temperature. ANPEC defines "Green" to mean lead-free (RoHS compliant) and halogen free (Br or Cl does not exceed 900ppm by weight in homogeneous material and total of Br and Cl does not exceed 1500ppm by weight).

ANPEC reserves the right to make changes to improve reliability or manufacturability without notice, and advise customers to obtain the latest version of relevant information to verify before placing orders.

## Absolute Maximum Ratings ( $T_A=25^\circ\text{C}$ unless otherwise noted) (Note 1)

Symbol	Parameter	Rating	Unit
$V_{DD}$	VDD Pin Supply Voltage	-0.3 to 20	V
$V_{DO, DOB}$	Output Pin (DO, DOB) Output Voltage	-0.3 to $V_{OUT-CLAMP}$	V
$I_{OUT}$	Maximum Output Pin (DO, DOB) Sink Current – Continuous <sup>(Note 2)</sup> Hold Peak (<100 $\mu\text{s}$ )	600 900 1200	mA
$T_J$	Maximum Junction Temperature	150	$^\circ\text{C}$
$T_{STG}$	Storage Temperature	-65 to 150	$^\circ\text{C}$
$T_{SOR}$	Maximum Lead Soldering Temperature, 10 Seconds	260	$^\circ\text{C}$

Note 1: Absolute Maximum Ratings are those values beyond which the life of a device may be impaired. Exposure to absolute maximum rating conditions for extended periods may affect device reliability.

Note 2: The maximum continuous current rating should refer recommend operating conditions ( $V_{DD}$ ,  $T_A$ ,  $T_J$ ) to guarantee reliability.

## Thermal Characteristics

Symbol	Parameter	Typical Value	Unit
$\theta_{JA}$	Thermal Resistance-Junction to Ambient <sup>(Note 3)</sup> TO-92M4 TSOT-23-5F	131 250	$^\circ\text{C/W}$
$P_D$	Power Dissipation, $T_A = 25^\circ\text{C}$ TO-92M4 TSOT-23-5F	950 500	mW

Note 3: The maximum allowable power dissipation at any  $T_A$  (ambient temperature) is calculated using:  $P_D(\text{max})=(T_J - T_A) / \theta_{JA}$ ;  $T_J=150^\circ\text{C}$ . Exceeding the maximum allowable power dissipation will result in excessive die temperature.

## Recommended Operating Conditions

Symbol	Parameter	Range	Unit
$V_{DD}$	VDD Supply Voltage	2.7 to 16	V
$T_A$	Operating Ambient Temperature	-40 to 105	$^\circ\text{C}$
$T_J$	Junction Temperature	-40 to 125	$^\circ\text{C}$

## Electrical Characteristics ( $T_A=25^\circ\text{C}$ , $V_{DD}=12\text{V}$ unless otherwise noted)

Symbol	Parameter	Test Conditions	APX284			Unit
			Min.	Typ.	Max.	
$I_{DD1}$	VDD Supply Current	$V_{DD} = 3\text{V}$ , Output Open	-	2	4	mA
$I_{DD2}$		$V_{DD} = 20\text{V}$ , Output Open	-	2	4	mA
$V_{SAT}$	Output Saturation Voltage	$V_{DD} = 12\text{V}$ , $I_{OUT} = 300\text{mA}$	-	210	300	mV
$V_{OUT-CLAMP}$	DO, DOB Output Clamp Voltage	DO, DOB Pin Off	20	24	28	V
$I_{DOH}$	DO Pin High Input Current	$V_{DD} = 12\text{V}$ , $B < B_{rp}$	-	120	200	$\mu\text{A}$
$I_{DOBH}$	DOB Pin High Input Current	$V_{DOB} = 12\text{V}$ , $B > B_{op}$	-	120	200	$\mu\text{A}$
$T_{ON}$	Lock Detection On Time		-	0.4	-	sec
$T_{OFF}$	Lock Detection Off Time		-	2.8	-	sec
$T_{OTS}$	Over-Temperature Shutdown Threshold		-	165	-	$^\circ\text{C}$
	Over-Temperature Shutdown Hysteresis		-	30	-	$^\circ\text{C}$

**Magnetic Characteristics** ( $T_A=25^{\circ}\text{C}$ ,  $V_{DD}=12\text{V}$  unless otherwise noted)

Symbol	Parameter	Test Conditions	APX284			Unit
			Min.	Typ.	Max.	
Bop	Magnetic Operation Point		5	20	40	Gauss
Brp	Magnetic Release Point		-40	-20	-5	Gauss
Bhys	Magnetic Hysteresis		30	40	50	Gauss

Typical Operating Characteristics

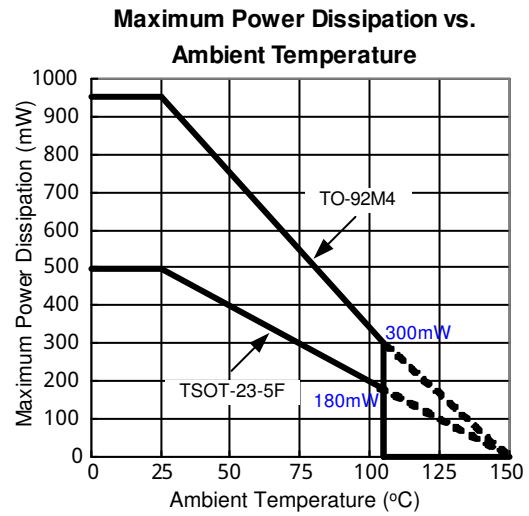
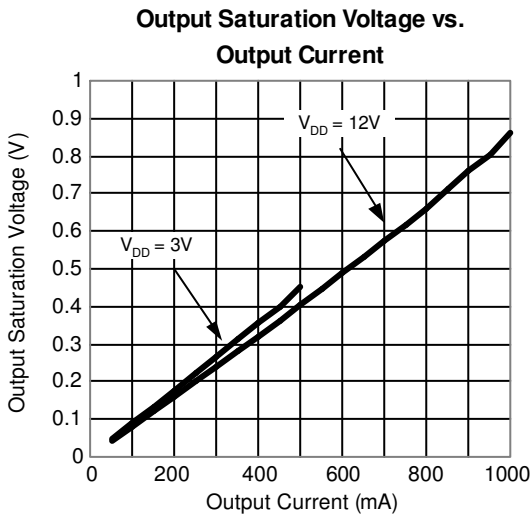
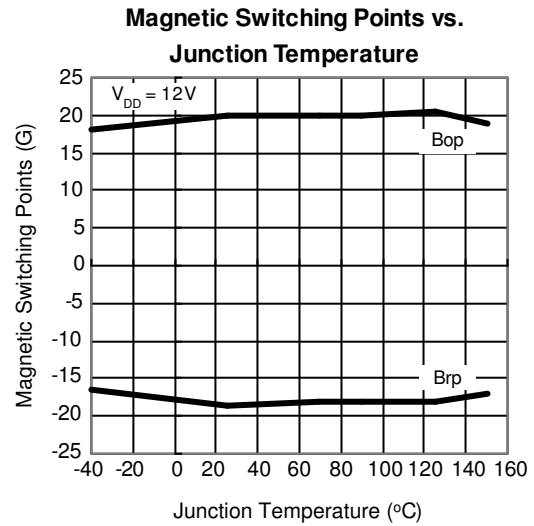
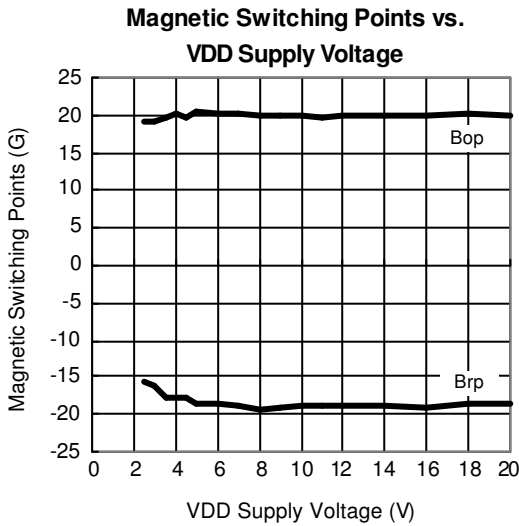
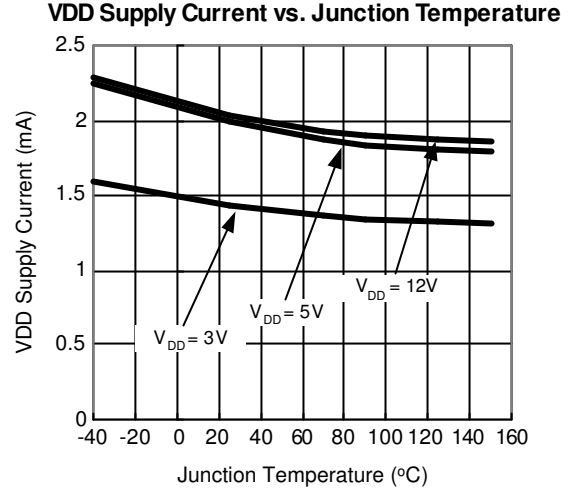
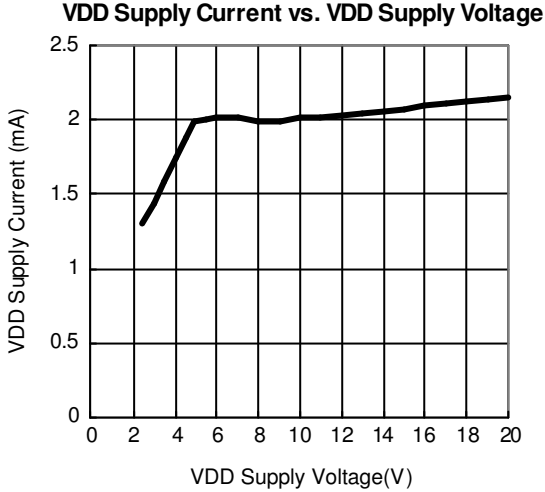

## Operating Waveforms

Rotation Mode Waveform (VIN=14V)

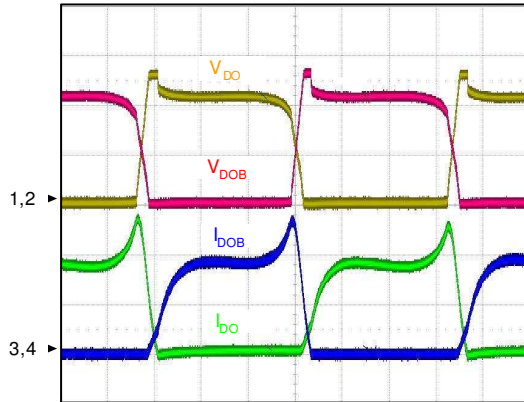

CH1:  $V_{DO}$ , 10V/div, DC  
 CH2:  $V_{DOB}$ , 10V/div, DC  
 CH3:  $I_{DOB}$ , 200mA/div, DC  
 CH4:  $I_{DO}$ , 200mA/div, DC  
 Time: 1ms/div

Lock Mode Waveform (VIN=14V)

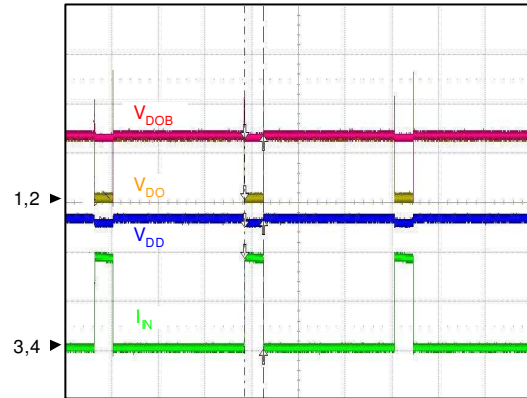

CH1:  $V_{DO}$ , 10V/div, DC  
 CH2:  $V_{DOB}$ , 10V/div, DC  
 CH3:  $V_{DD}$ , 5V/div, DC  
 CH4:  $I_{IN}$ , 500mA/div, DC  
 Time: 1s/div

## Pin Description

TO-92M4

PIN		FUNCTION
NO.	NAME	
1	VDD	Supply Voltage Input.
2	DO	Open Drain Output. Controlled by magnetic field input.
3	DOB	Open Drain Output. Controlled by magnetic field input.
4	GND	Ground of the IC.

TSOT-23-5F

PIN		FUNCTION
NO.	NAME	
1	NC	No connection.
2	GND	Ground of the IC.
3	DOB	Open Drain Output. Controlled by magnetic field input.
4	DO	Open Drain Output. Controlled by magnetic field input.
5	VDD	Supply Voltage Input.

Block Diagram

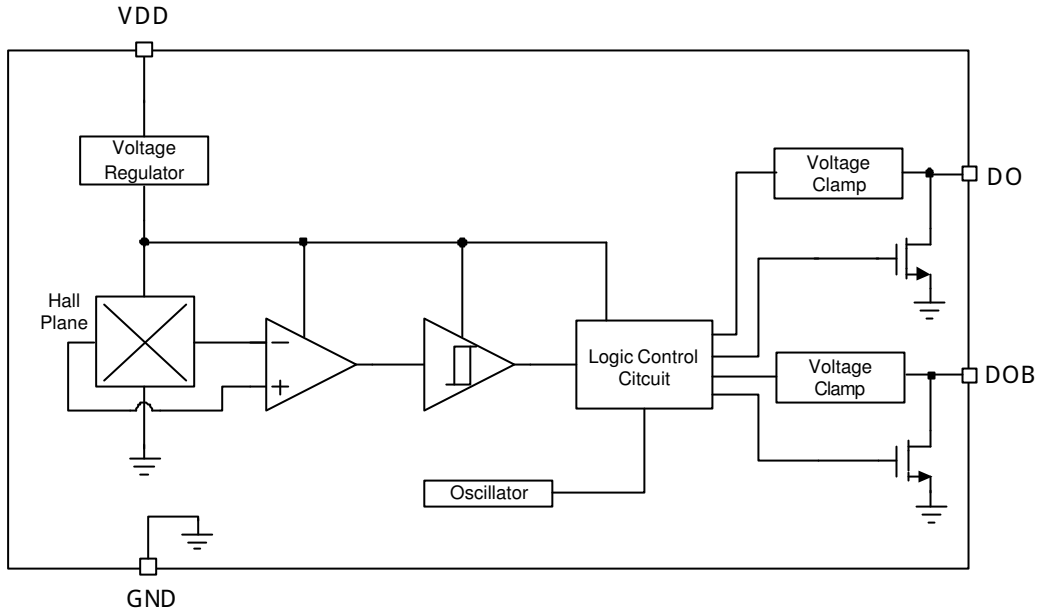

Typical Application Circuit

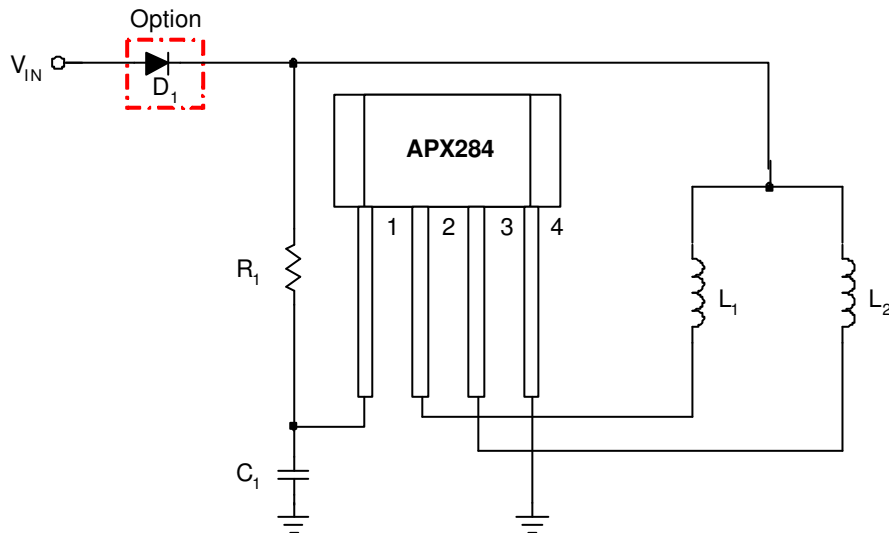

Notes:  $D_1$  is to protect IC and coils when reverse power input.  
 $C_1$ : typical  $1\mu\text{F}/25\text{V}$  capacitor recommended.  
 $R_1$ : typical  $5.1\Omega$  resistor recommended.  
 The  $R_1$  and  $C_1$  are to avoid inrush current to damage IC at hot plug ON/OFF moments and the  $R_1$  and  $C_1$  values need to be selected base on coils design.

## Function Description

### Output Switch Principle

The APX284 builds in a Hall-effect sensor plane to sense the vertical magnetic flux density (B). There are two output drivers in APX284 to drive two-phase DC brushless motor. When the South pole magnetic field is close to the IC marking surface and the magnetic flux density higher than operate point (Bop), the DO pin output will turn ON and the DOB pin output will turn OFF. When the South pole magnetic field far away the IC marking surface and North pole magnetic field close to the IC marking surface until the magnetic flux density higher than release point (Brp), the DO pin output will turn OFF and the DOB pin output will turn ON.

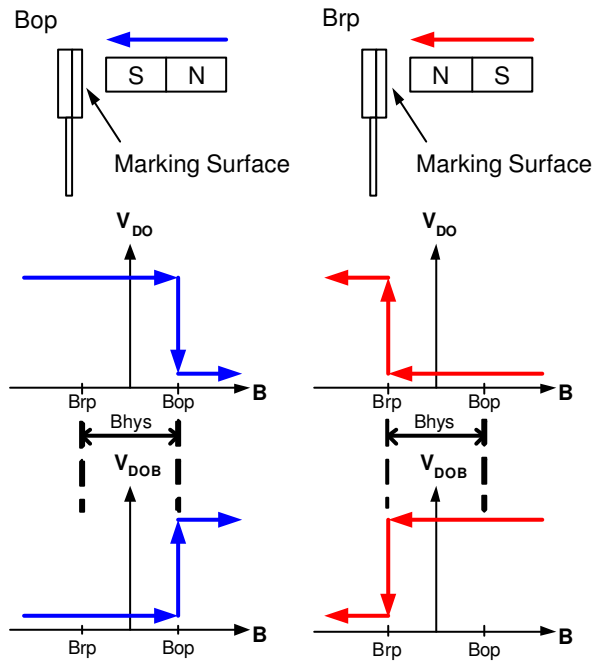

### Lockup Protection and Automatic Restart

The APX284 detects the rotation of the motor by internal hall sensor signal, and adjusts lock detection ON time (T<sub>ON</sub>) and lock detection OFF time (T<sub>OFF</sub>) by internal counter.

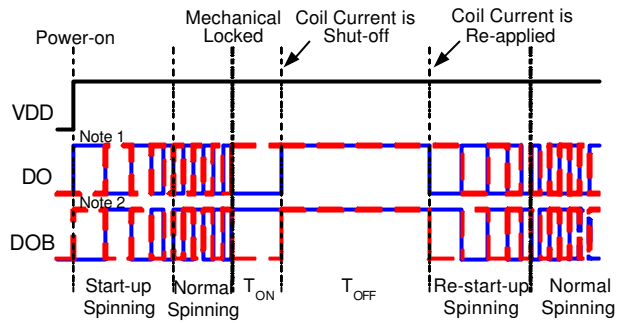

### Thermal Protection

The APX284 has a thermal protection. When the internal junction temperature reaches 165°C, the output devices will be switched off. When the IC's junction temperature cools by 30°C, the thermal sensor will turn the output devices on again, resulting in a pulsed output during continuous thermal protection.

Package Information

TO-92M4

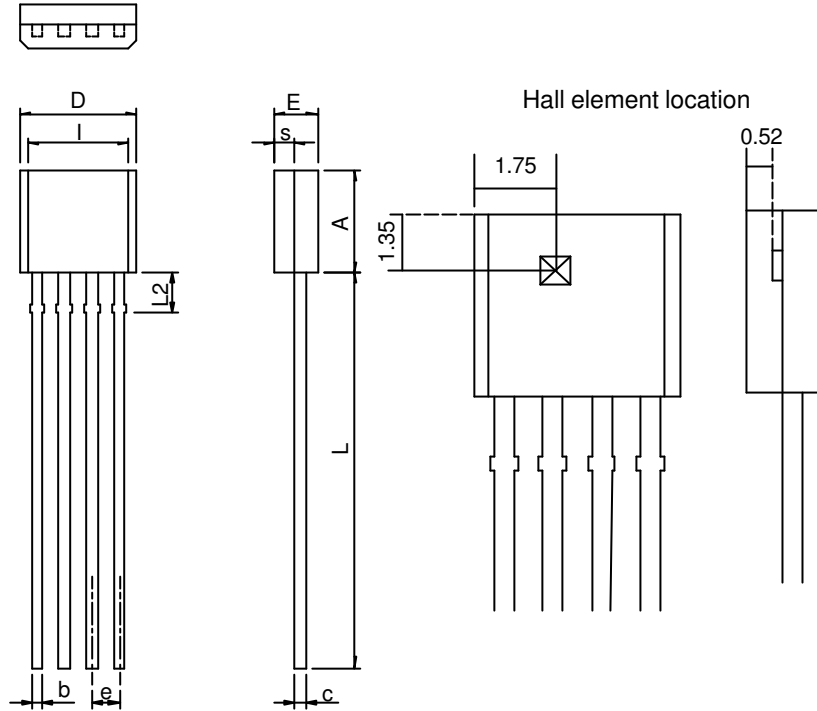

Sensitive Area (0.286x0.286mm<sup>2</sup>)  
 Position of Hall Sensor  
 reference to the top-left of package  
 x= 1.35±0.1mm  
 y= 1.75±0.1mm

SYMBOL	TO-92M4			
	MILLIMETERS		INCHES	
	MIN.	MAX.	MIN.	MAX.
A	3.45	3.75	0.136	0.148
b	0.31	0.56	0.012	0.022
c	0.35	0.51	0.014	0.020
D	4.98	5.32	0.196	0.209
e	1.27 BSC		0.050 BSC	
E	1.40	1.80	0.055	0.071
I	3.78	4.67	0.149	0.184
L	13.50	15.80	0.531	0.622
L2	1.34	1.65	0.053	0.065
s	0.50	0.90	0.020	0.035



Package Information

TSOT-23-5F

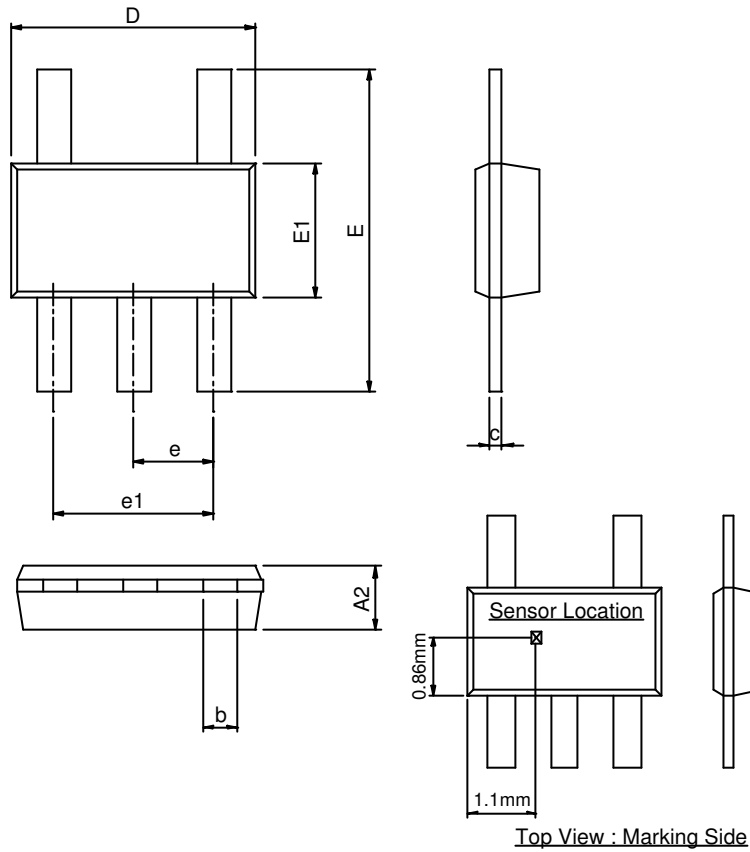

SYMBOL	TSOT-23-5F			
	MILLIMETERS		INCHES	
	MIN.	MAX.	MIN.	MAX.
A2	0.70	0.775	0.028	0.031
b	0.30	0.50	0.012	0.020
c	0.08	0.22	0.003	0.009
D	2.80	3.00	0.110	0.118
E	3.70	3.90	0.146	0.154
E1	1.50	1.70	0.059	0.067
e	0.95 BSC		0.037 BSC	
e1	1.90 BSC		0.075 BSC	

Note : 1. Dimension D and E1 do not include mold flash, protrusions or gate burrs. Mold flash, protrusion or gate burrs shall not exceed 10 mil per side.

Carrier Tape & Reel Dimensions

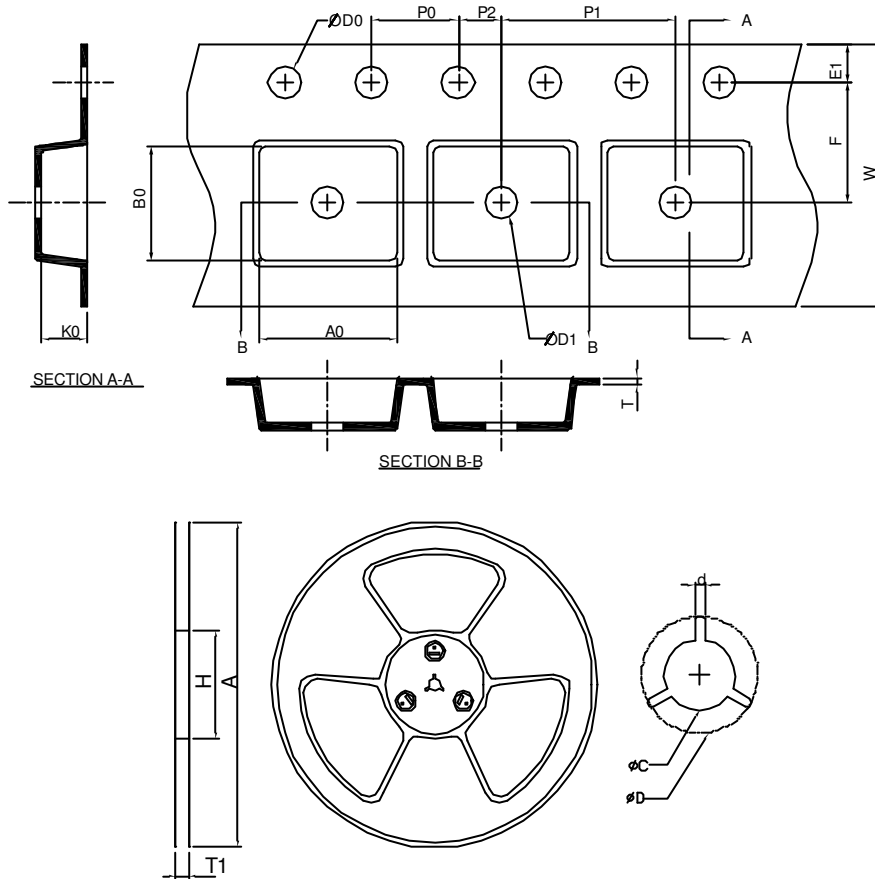

Application	A	H	T1	C	d	D	W	E1	F
TSOT-23-5F	178.0±2.00	50 MIN.	16.4+2.00 -0.00	13.0+0.50 -0.20	1.5 MIN.	20.2 MIN.	12.0±0.30	1.75±0.10	5.50±0.10
	P0	P1	P2	D0	D1	T	A0	B0	K0
	4.0±0.10	4.0±0.10	2.0±0.05	1.5+0.10 -0.00	1.0 MIN.	0.6+0.00 -0.40	3.10±0.20	4.00±0.20	1.30±0.20

(mm)

Devices Per Unit

Package Type	Unit	Quantity
TSOT-23-5F	Tape & Reel	3000

### Taping Direction Information

TSOT-23-5F

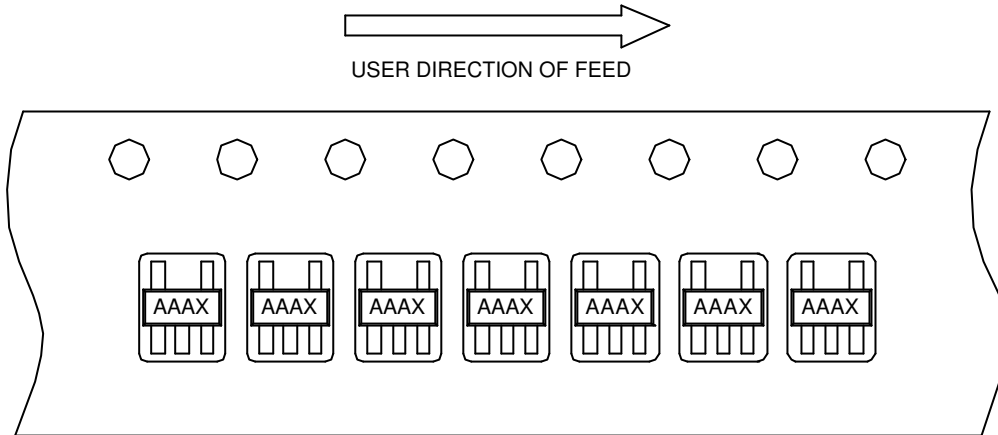

### Classification Profile

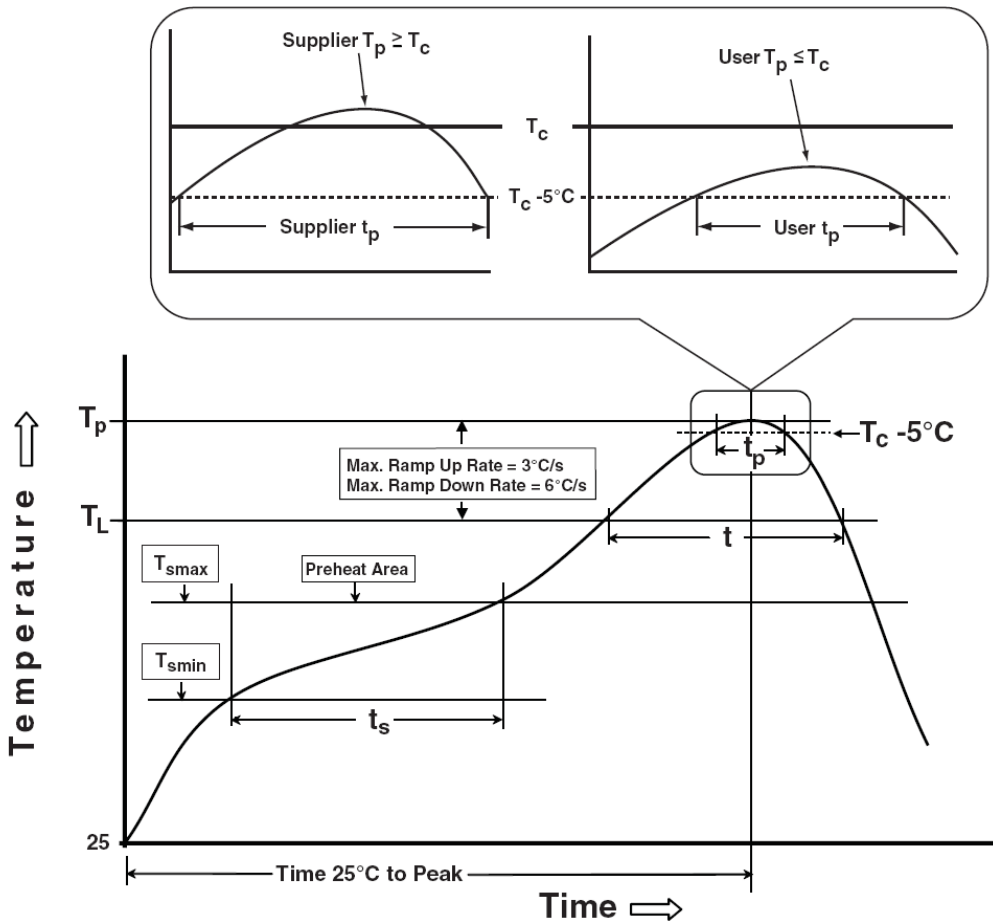

### Classification Reflow Profiles

Profile Feature	Sn-Pb Eutectic Assembly	Pb-Free Assembly
<b>Preheat &amp; Soak</b>		
Temperature min ( $T_{smin}$ )	100 °C	150 °C
Temperature max ( $T_{smax}$ )	150 °C	200 °C
Time ( $T_{smin}$ to $T_{smax}$ ) ( $t_s$ )	60-120 seconds	60-120 seconds
Average ramp-up rate ( $T_{smax}$ to $T_p$ )	3 °C/second max.	3 °C/second max.
Liquidous temperature ( $T_L$ )	183 °C	217 °C
Time at liquidous ( $t_L$ )	60-150 seconds	60-150 seconds
Peak package body Temperature ( $T_p$ )*	See Classification Temp in table 1	See Classification Temp in table 2
Time ( $t_p$ )** within 5°C of the specified classification temperature ( $T_c$ )	20** seconds	30** seconds
Average ramp-down rate ( $T_p$ to $T_{smax}$ )	6 °C/second max.	6 °C/second max.
Time 25°C to peak temperature	6 minutes max.	8 minutes max.
* Tolerance for peak profile Temperature ( $T_p$ ) is defined as a supplier minimum and a user maximum.		
** Tolerance for time at peak profile temperature ( $t_p$ ) is defined as a supplier minimum and a user maximum.		

Table 1. SnPb Eutectic Process – Classification Temperatures ( $T_c$ )

Package Thickness	Volume mm <sup>3</sup> <350	Volume mm <sup>3</sup> ≥350
<2.5 mm	235 °C	220 °C
≥2.5 mm	220 °C	220 °C

Table 2. Pb-free Process – Classification Temperatures ( $T_c$ )

Package Thickness	Volume mm <sup>3</sup> <350	Volume mm <sup>3</sup> 350-2000	Volume mm <sup>3</sup> >2000
<1.6 mm	260 °C	260 °C	260 °C
1.6 mm – 2.5 mm	260 °C	250 °C	245 °C
≥2.5 mm	250 °C	245 °C	245 °C

### Reliability Test Program

Test item	Method	Description
SOLDERABILITY	JESD-22, B102	5 Sec, 245°C
HOLT	JESD-22, A108	1000 Hrs. Bias @ $T_r=125^\circ\text{C}$
PCT	JESD-22, A102	168 Hrs, 100%RH, 2atm, 121°C
TCT	JESD-22, A104	500 Cycles, -65°C~150°C
HBM	MIL-STD-883-3015.7	VHBM ≥ 2KV
MM	JESD-22, A115	VMM ≥ 200V
Latch-Up	JESD 78	10ms, $1_{tr} \geq 100\text{mA}$

**Customer Service**

**Anpec Electronics Corp.**

Head Office :

No.6, Dusing 1st Road, SBIP,  
Hsin-Chu, Taiwan  
Tel : 886-3-5642000  
Fax : 886-3-5642050

Taipei Branch :

2F, No. 11, Lane 218, Sec 2 Jhongsing Rd.,  
Sindian City, Taipei County 23146, Taiwan  
Tel : 886-2-2910-3838  
Fax : 886-2-2917-3838

## X-ON Electronics

Largest Supplier of Electrical and Electronic Components

*Click to view similar products for [Motor/Motion/Ignition Controllers & Drivers](#) category:*

*Click to view products by [Anpec](#) manufacturer:*

Other Similar products are found below :

[LV8133JA-ZH](#) [LV8169MUTBG](#) [LV8774Q-AH](#) [LV8860PV-TLM-H](#) [MC33931EKR2](#) [MC34GD3000EP](#) [FSB50250UTD](#) [FSB50550TB2](#)  
[FSBF15CH60BTH](#) [FSBS10CH60T](#) [MP6507GR-P](#) [MP6508GF](#) [MSVCPM2-63-12](#) [MSVGW45-14-2](#) [MSVGW54-14-5](#) [NTE7043](#)  
[CAT3211MUTAG](#) [LA6245P-CL-TLM-E](#) [LA6245P-TLM-E](#) [LA6565VR-TLM-E](#) [LB11650-E](#) [LB1694N-E](#) [LB1837M-TLM-E](#) [LB1845DAZ-](#)  
[XE](#) [LC898111AXB-MH](#) [LC898300XA-MH](#) [SS30-TE-L-E](#) [STK531-345A-E](#) [STK581U3A0D-E](#) [STK58AUNP0D-E](#) [STK621-068C-E](#)  
[STK621-140C](#) [STK621-728S-E](#) [STK625-728-E](#) [STK672-400B-E](#) [STK672-432AN-E](#) [STK672-432BN-E](#) [STK672-440AN-E](#) [STK672-](#)  
[442AN-E](#) [AMIS30621AUA](#) [FSB50550ASE](#) [26700](#) [LV8161MUTAG](#) [LV8281VR-TLM-H](#) [LV8702V-TLM-H](#) [LV8734VZ-TLM-H](#)  
[LV8773Z-E](#) [LV8807QA-MH](#) [MC33932EK](#) [MCP8024T-H/MP](#)