

Single-Phase Full-Wave Motor Driver with Built-in Hall Sensor

Features

- **On-Chip Hall Sensor**
- **Silent Driver**
- **High Sensitivity Hall Effect Sensor IC: ±15G(Type.)**
- **Built-in Lock Protection and Auto Restart Function**
- **Built-In Thermal Protection Circuit**
- **4 Pin TO92-M4 Package**
- **Lead Free and Green Devices Available (RoHS Compliant)**

General Description

The APX9166 is an integrated Hall Effect Sensor IC designed for electric commutation of single-phase DC brushless motor applications. The device is built-in lock protection. When fan is locked, the device will enter the lock protection mode. It is also with thermal shutdown function. The APX9166 is available in a low cost TO92-M4 package.

Pin Description

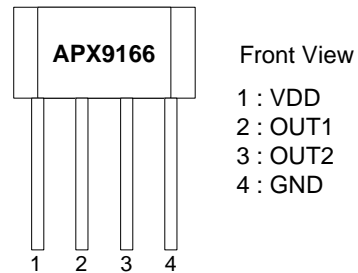

Applications

- **Brushless DC Fans**
- **Brushless DC Motors**

Ordering and Marking Information

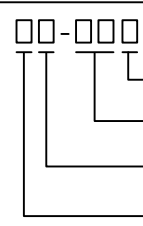
APX9166	 <ul style="list-style-type: none"> — Assembly Material — Handling Code — Temperature Range — Package Code 	Package Code E : TO - 92M4 Temperature Range I : -40 to 105 °C Handling Code PB : Plastic Bag Assembly Material G : Halogen and Lead Free Device
APX9166 E :	<div style="border: 1px solid black; padding: 2px; display: inline-block;"> APX 9166 XXXXX </div>	XXXXXX - Date Code

Note: ANPEC lead-free products contain molding compounds/die attach materials and 100% matte tin plate termination finish; which are fully compliant with RoHS. ANPEC lead-free products meet or exceed the lead-free requirements of IPC/JEDEC J-STD-020D for MSL classification at lead-free peak reflow temperature. ANPEC defines "Green" to mean lead-free (RoHS compliant) and halogen free (Br or Cl does not exceed 900ppm by weight in homogeneous material and total of Br and Cl does not exceed 1500ppm by weight).

ANPEC reserves the right to make changes to improve reliability or manufacturability without notice, and advise customers to obtain the latest version of relevant information to verify before placing orders.

Absolute Maximum Ratings ($T_A=25^{\circ}\text{C}$ unless otherwise noted) (Note 1)

Symbol	Parameter	Rating	Unit
V_{DD}	VDD Pin Supply Voltage (VDD to GND)	-0.3 to 20	V
V_{OUT}	Output Pin (OUT1, OUT2) Output Voltage	-0.3 to 20	V
I_{OUT}	Output Pin (OUT1, OUT2) Maximum Output Current – Continuous	450	mA
	Hold	1000	
	Peak	1200	
T_J	Maximum Junction Temperature	150	$^{\circ}\text{C}$
T_{STG}	Storage Temperature	-65 to 150	$^{\circ}\text{C}$
T_{SOR}	Maximum Lead Soldering Temperature, 10 Seconds	260	$^{\circ}\text{C}$

Note1: Stresses beyond those listed under "absolute maximum ratings" may cause permanent damage to the device. These are stress ratings only and functional operation of the device at these or any other conditions beyond those indicated under "recommended operating conditions" is not implied. Exposure to absolute maximum rating conditions for extended periods may affect device reliability.

Thermal Characteristics

Symbol	Parameter	Typical Value	Unit
R_{THJA}	Thermal Resistance-Junction to Ambient (Note 2) TO-92M4	131	$^{\circ}\text{C}/\text{W}$
P_D	Power Dissipation, $T_A = 25^{\circ}\text{C}$ TO-92M4	950	mW

Note 3 : The maximum allowable power dissipation at any T_A (ambient temperature) is calculated using: $P_D (\text{max}) = (T_J - T_A) / \theta_{JA}$; $T_J = 150^{\circ}\text{C}$. Exceeding the maximum allowable power dissipation will result in excessive die temperature.

Recommended Operating Conditions

Symbol	Parameter	Range	Unit
V_{DD}	VDD Supply Voltage	2.2 to 17	V
T_A	Operating Ambient Temperature	-40 to 105	$^{\circ}\text{C}$
T_J	Junction Temperature	-40 to 125	$^{\circ}\text{C}$

Electrical Characteristics ($T_A=25^{\circ}\text{C}$, $V_{DD}=12\text{V}$ unless otherwise noted)

Symbol	Parameter	Test Conditions	APX9166			Unit
			Min.	Typ.	Max.	
I_{DD}	VDD Supply Current	$V_{DD}=17\text{V}$, no load		5.5	6.5	mA
V_O	Output Driver Saturation Voltage	$I_{OUT}=400\text{mA}$, Upper and Lower total	-	0.65	0.8	V
T_{ON}	Lock Detection On Time		0.28	0.4	0.52	sec
T_{OFF}	Lock Detection Off Time		2.8	4	5.2	sec
R_{TLK}	T_{OFF}/T_{ON} Ratio		8	10	12	-
I_{LIM}	Internal Current Limit (50% Output)		-	1100	-	mA
OTS	Over Temperature Shutdown Threshold		-	165	-	$^{\circ}\text{C}$
	Over Temperature Shutdown Hysteresis		-	30	-	$^{\circ}\text{C}$

Magnetic Characteristics ($T_A=25^{\circ}\text{C}$, $V_{DD}=12\text{V}$ unless otherwise noted)

Symbol	Parameter	Test Conditions	APX9166			Unit
			Min.	Typ.	Max.	
Bop	Magnetic Operation Point		5	15	30	Gauss
Brp	Magnetic Release Point		-30	-15	-5	Gauss
Bhys	Magnetic Hysteresis		-	30	-	Gauss

Typical Operating Characteristics

VDD Supply Current vs. VDD Supply Voltage

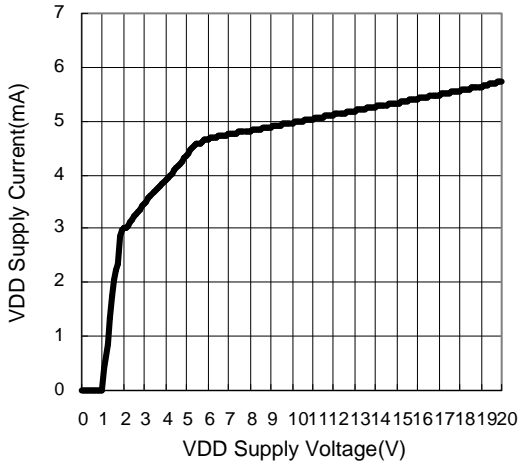

Output Saturation Voltage vs. Output Current

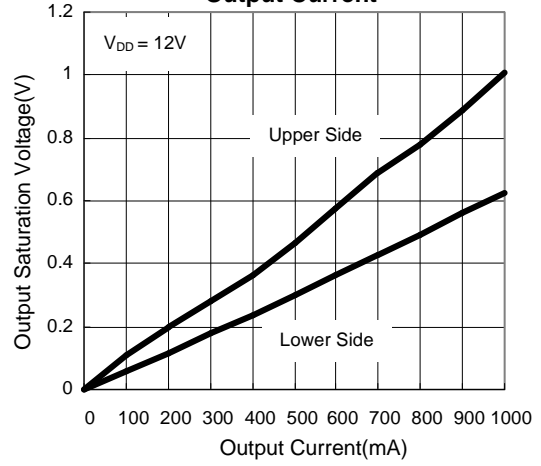

Magnetic Switching Points vs. VDD Supply Voltage

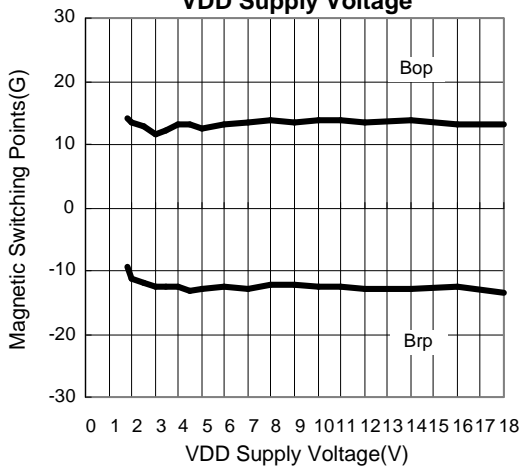

Magnetic Switching Points vs. Junction Temperature

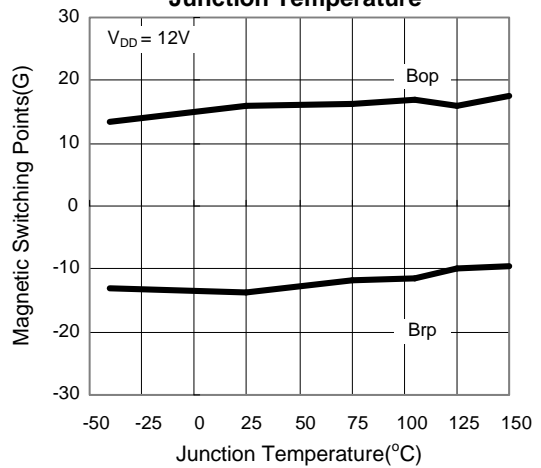

Maximum Power Dissipation vs. Ambient Temperature

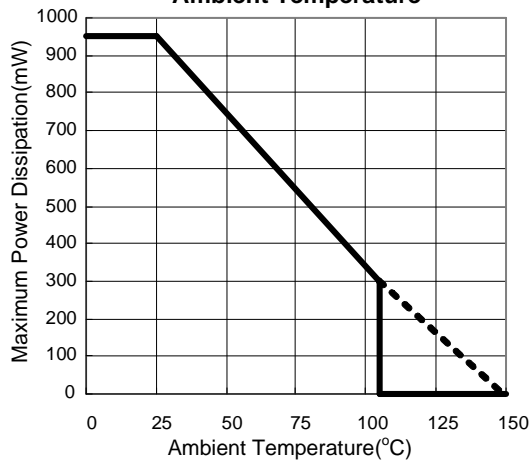

Pin Description

PIN		FUNCTION
NO.	NAME	
1	VDD	Supply Voltage Input.
2	OUT1	H-bridge output connection.
3	OUT2	H-bridge output connection.
4	GND	Ground of the IC.

Block Diagram

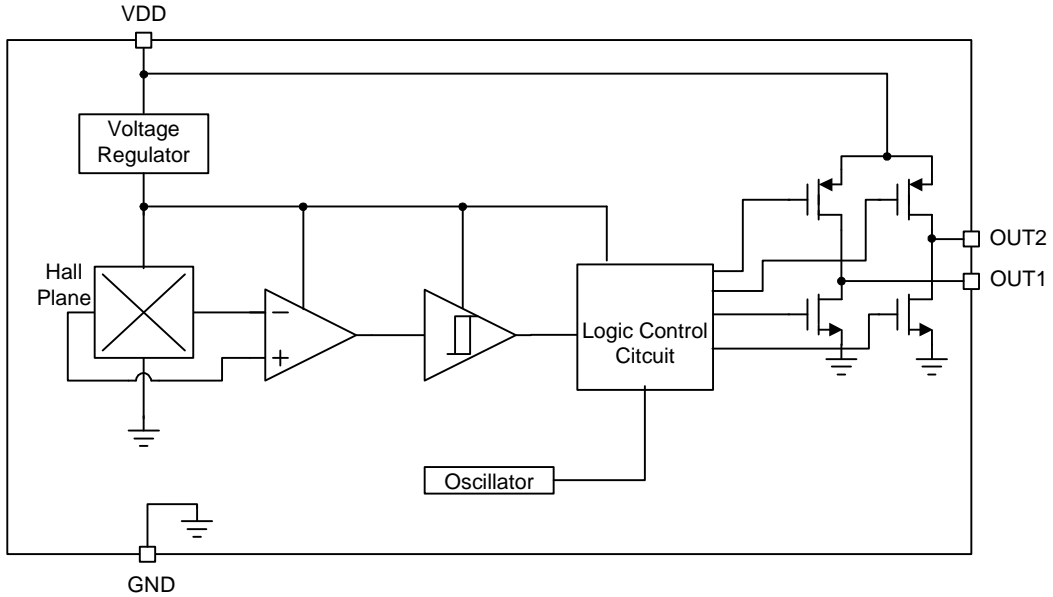

Typical Application Circuit

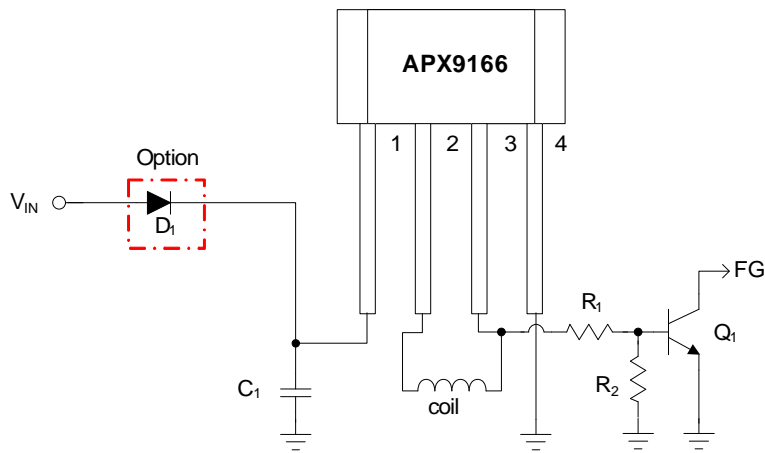

Notes: D₁ is to protect IC when reverse power input
 C₁ must use at least 1μF/25V capacitor and place as close to IC as possible .
 R₁, R₂ and Q₁ are for FG function application circuit (by OUT2 only).

Function Description

Output Switch Principle

The APX9166 built in a Hall-effect sensor plane to sense the vertical magnetic flux density (B). There are two output drivers in APX9166 to drive single-phase DC brushless motor. When the S pole magnetic field close to the IC marking surface and the magnetic flux density higher than operate point (Bop), the OUT1 pin output will turn to LOW and the OUT2 pin output will turn to HIGH. When the S pole magnetic field far away the IC marking surface and N pole magnetic field close to the IC marking surface until the magnetic flux density higher than release point (Brp), the OUT1 pin output will turn HIGH and the OUT2 pin output will turn LOW.

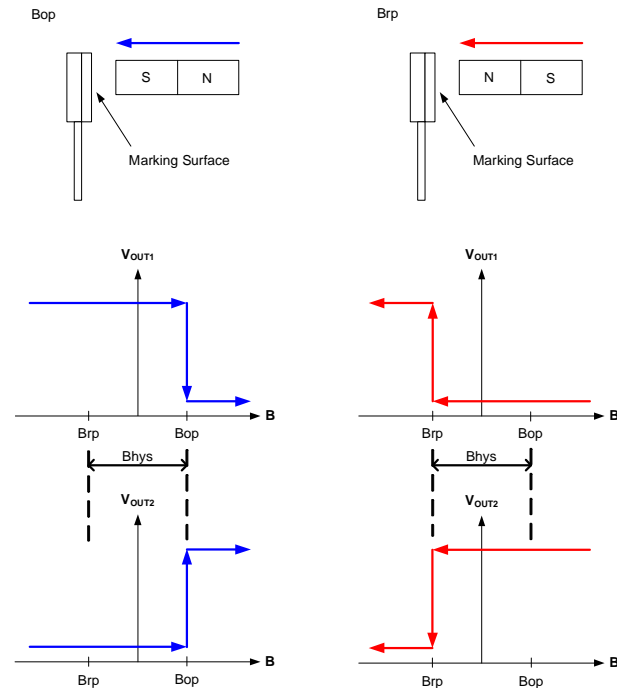

Lockup Protection and Automatic Restart

The APX9166 detects the rotation of the motor by internal hall sensor signal, and adjusts lock detection ON time (T_{ON}) and lock detection OFF time (T_{OFF}) by internal counter.

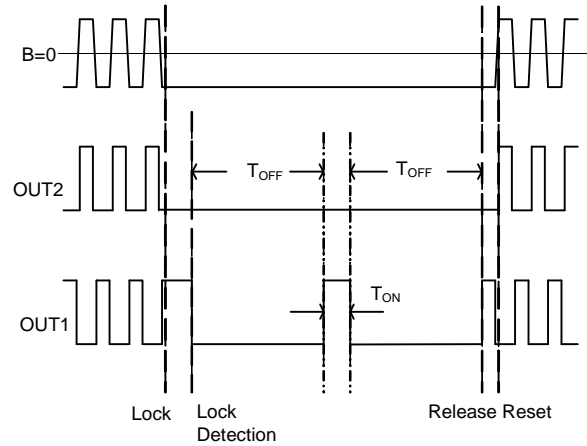

Thermal Protection

The APX9166 has a thermal protection. When the internal junction temperature reaches 165°C, the output devices will be switched off. When the IC's junction temperature cools by 30°C, the thermal sensor will turn the output devices on again, resulting in a pulsed output during continuous thermal protection.

Package Information

TO-92M4

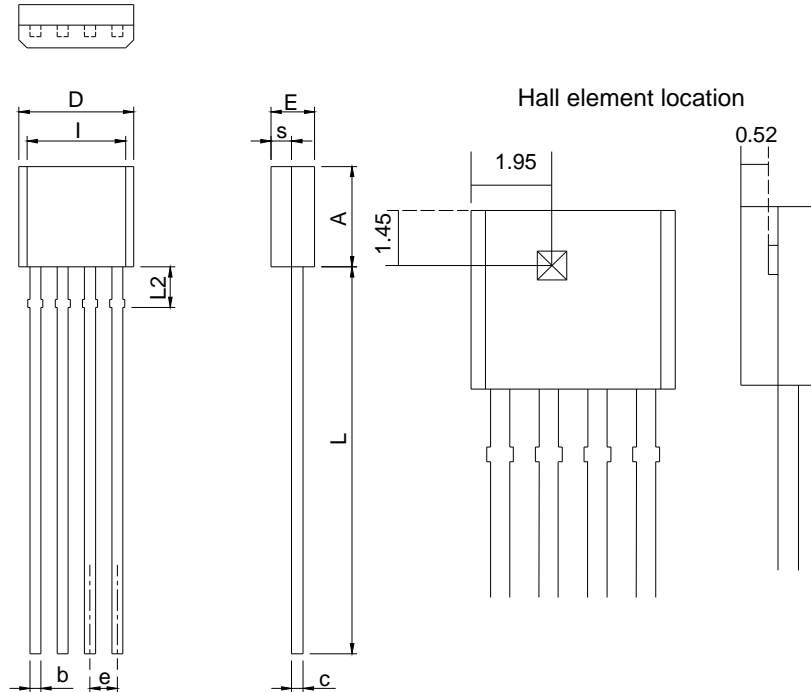

Sensitive Area (0.286x0.286mm²)
 Position of Hall Sensor
 reference to the top-left of package
 x= 1.45±0.1mm
 y= 1.95±0.1mm

SYMBOL	TO-92M4			
	MILLIMETERS		INCHES	
	MIN.	MAX.	MIN.	MAX.
A	3.45	3.75	0.136	0.148
b	0.31	0.56	0.012	0.022
c	0.35	0.51	0.014	0.020
D	4.98	5.32	0.196	0.209
e	1.27 BSC		0.050 BSC	
E	1.40	1.80	0.055	0.071
I	3.78	4.67	0.149	0.184
L	13.50	15.80	0.531	0.622
L2	1.34	1.65	0.053	0.065
s	0.50	0.90	0.020	0.035

Classification Profile

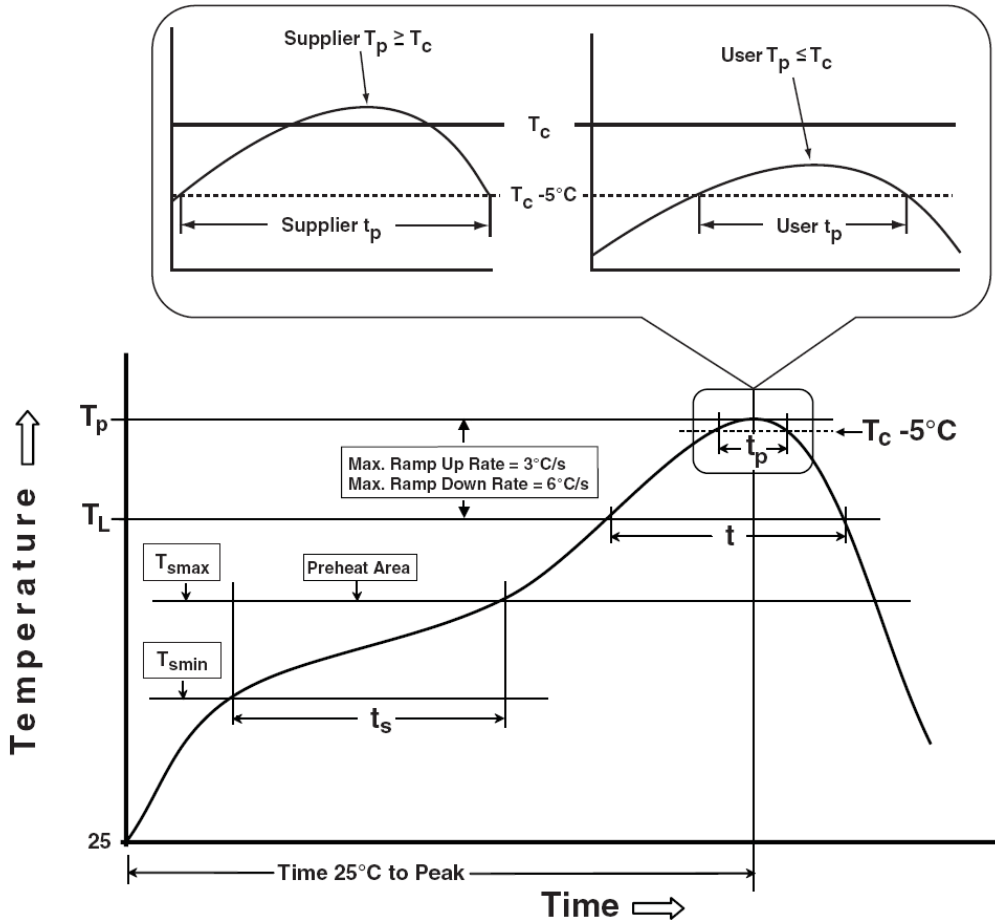

Classification Reflow Profiles

Profile Feature	Sn-Pb Eutectic Assembly	Pb-Free Assembly
Preheat & Soak		
Temperature min (T_{smin})	100 °C	150 °C
Temperature max (T_{smax})	150 °C	200 °C
Time (T_{smin} to T_{smax}) (t_s)	60-120 seconds	60-120 seconds
Average ramp-up rate (T_{smax} to T_p)	3 °C/second max.	3°C/second max.
Liquidous temperature (T_L)	183 °C	217 °C
Time at liquidous (t_l)	60-150 seconds	60-150 seconds
Peak package body Temperature (T_p)*	See Classification Temp in table 1	See Classification Temp in table 2
Time (t_p)** within 5°C of the specified classification temperature (T_c)	20** seconds	30** seconds
Average ramp-down rate (T_p to T_{smax})	6 °C/second max.	6 °C/second max.
Time 25°C to peak temperature	6 minutes max.	8 minutes max.

* Tolerance for peak profile Temperature (T_p) is defined as a supplier minimum and a user maximum.
 ** Tolerance for time at peak profile temperature (t_p) is defined as a supplier minimum and a user maximum.

Classification Reflow Profiles (Cont.)

Table 1. SnPb Eutectic Process – Classification Temperatures (Tc)

Package Thickness	Volume mm ³ <350	Volume mm ³ ≥350
<2.5 mm	235 °C	220 °C
≥2.5 mm	220 °C	220 °C

Table 2. Pb-free Process – Classification Temperatures (Tc)

Package Thickness	Volume mm ³ <350	Volume mm ³ 350-2000	Volume mm ³ >2000
<1.6 mm	260 °C	260 °C	260 °C
1.6 mm – 2.5 mm	260 °C	250 °C	245 °C
≥2.5 mm	250 °C	245 °C	245 °C

Reliability Test Program

Test item	Method	Description
SOLDERABILITY	JESD-22, B102	5 Sec, 245°C
HOLT	JESD-22, A108	1000 Hrs, Bias @ T _j =125°C
PCT	JESD-22, A102	168 Hrs, 100%RH, 2atm, 121°C
TCT	JESD-22, A104	500 Cycles, -65°C~150°C
HBM	MIL-STD-883-3015.7	VHBM ≥ 2KV
MM	JESD-22, A115	VMM ≥ 200V
Latch-Up	JESD 78	10ms, 1 _{tr} ≥ 100mA

Customer Service

Anpec Electronics Corp.

Head Office :

No.6, Dusing 1st Road, SBIP,
Hsin-Chu, Taiwan
Tel : 886-3-5642000
Fax : 886-3-5642050

Taipei Branch :

2F, No. 11, Lane 218, Sec 2 Jhongsing Rd.,
Sindian City, Taipei County 23146, Taiwan
Tel : 886-2-2910-3838
Fax : 886-2-2917-3838

X-ON Electronics

Largest Supplier of Electrical and Electronic Components

Click to view similar products for [Motor/Motion/Ignition Controllers & Drivers](#) category:

Click to view products by [Anpec](#) manufacturer:

Other Similar products are found below :

[LV8133JA-ZH](#) [LV8169MUTBG](#) [LV8774Q-AH](#) [LV8860PV-TLM-H](#) [MC33931EKR2](#) [MC34GD3000EP](#) [FSB50250UTD](#) [FSB50550TB2](#)
[FSBF15CH60BTH](#) [FSBS10CH60T](#) [MP6507GR-P](#) [MP6508GF](#) [MSVCPM2-63-12](#) [MSVGW45-14-2](#) [MSVGW54-14-5](#) [NTE7043](#)
[CAT3211MUTAG](#) [LA6245P-CL-TLM-E](#) [LA6245P-TLM-E](#) [LA6565VR-TLM-E](#) [LB11650-E](#) [LB1694N-E](#) [LB1837M-TLM-E](#) [LB1845DAZ-](#)
[XE](#) [LC898111AXB-MH](#) [LC898300XA-MH](#) [SS30-TE-L-E](#) [STK531-345A-E](#) [STK581U3A0D-E](#) [STK58AUNP0D-E](#) [STK621-068C-E](#)
[STK621-140C](#) [STK621-728S-E](#) [STK625-728-E](#) [STK672-400B-E](#) [STK672-432AN-E](#) [STK672-432BN-E](#) [STK672-440AN-E](#) [STK672-](#)
[442AN-E](#) [AMIS30621AUA](#) [FSB50550ASE](#) [26700](#) [LV8161MUTAG](#) [LV8281VR-TLM-H](#) [LV8702V-TLM-H](#) [LV8734VZ-TLM-H](#)
[LV8773Z-E](#) [LV8807QA-MH](#) [MC33932EK](#) [MCP8024T-H/MP](#)