

High-Efficiency, 1-Cell and 2-Cell Boost Converter

Description

The FP6714 is a high efficiency, fixed frequency 1.0MHz, current mode PWM boost DC/DC converter which could operate from single/dual-cell NiCd, NiMH or alkaline battery such as input voltage below 1V. The converter output voltage can be adjusted from 1.8V to a maximum of 3.8V by an external resistor divider. Besides the converter includes a 0.25Ω N-channel MOSFET switch and 0.35Ω P-channel synchronous rectifier. So no external Schottky diode is required and could get better efficiency near 94%.

The converter is based on a fixed frequency, current mode, pulse-width-modulation PWM controller that goes automatically into PSM mode at light load which quiescent current is only 25μA in this mode operation.

When converter operation into discontinuous mode, the internal anti-ringing switch will reduce interference and radiated electromagnetic energy. The FP6714 is available in a space-saving SOT-23-6 & TSOT-23-6 packages for portable application.

Pin Assignments

S6 Package (SOT-23-6)

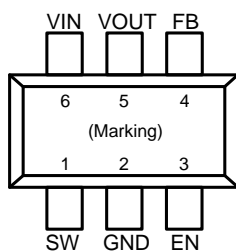

S9 Package (TSOT-23-6)

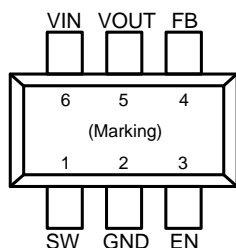

Figure 1. Pin Assignment of FP6714

Features

- Synchronous Rectification: 94% Efficiency
- Very Low Start-up Voltage at 0.85V
- Automatically Switch to PSM Mode for Improving Efficiency at Light Load
- Internal Anti-Ringing Switch Across Inductor
- Fixed Frequency Operation at 1.0MHz
- Very Low Shutdown Current at 1μA
- Small SOT-23-6 & TSOT-23-6 Packages
- RoHS Compliant

Applications

- Handheld Instrument
- Cordless Phone
- Wireless Handset
- GPS Receiver
- MP3

Ordering Information

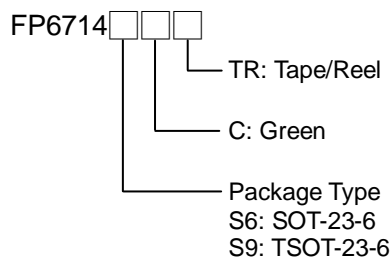

SOT-23-6 Marking

| Part Number | Product Code |
|-------------|--------------|
| FP6714S6C | FB3 |

TSOT-23-6 Marking

| Part Number | Product Code |
|-------------|--------------|
| FP6714S9C | FL7 |

Typical Application Circuit

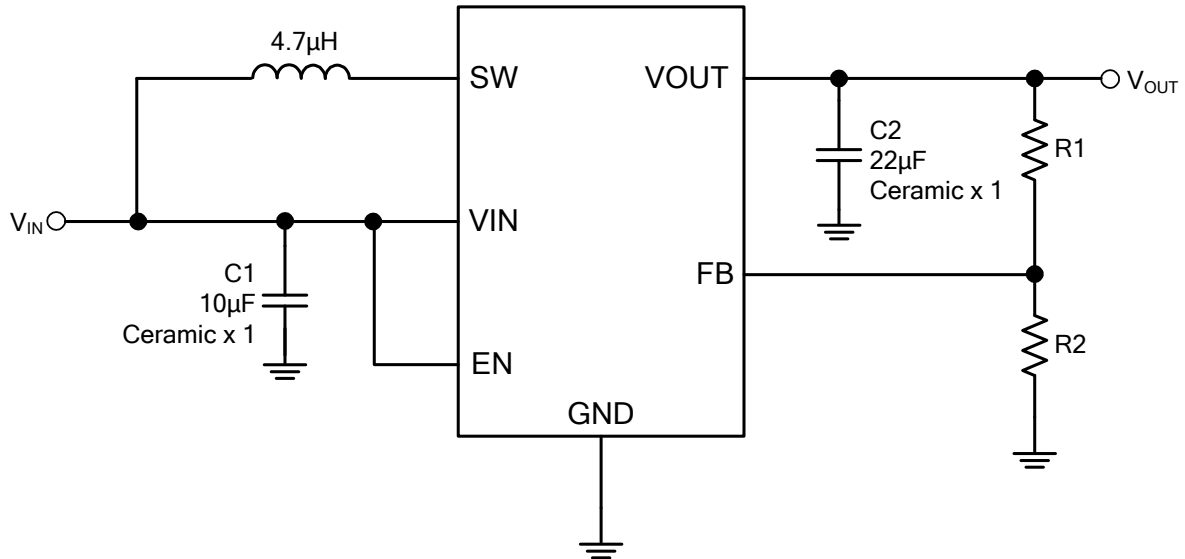

Figure 2. Typical Application Circuit of FP6714

Functional Pin Description

| Pin Name | Pin No. | Pin Function |
|----------|---------|---|
| EN | 3 | Chip-enable input. The converter will work when this pin is connected to logic high. It will shut off when this pin is connected to logic low. |
| FB | 4 | The feedback input for adjusting output voltage. This pin connects resistor divider that output voltage could be adjusted from 1.8V to 3.8V. The feedback voltage is typical at 0.5V. |
| GND | 2 | Ground pin |
| VOUT | 5 | Output voltage pin |
| VIN | 6 | Input voltage pin |
| SW | 1 | Switch node pin which is connected to inductor. |

Block Diagram

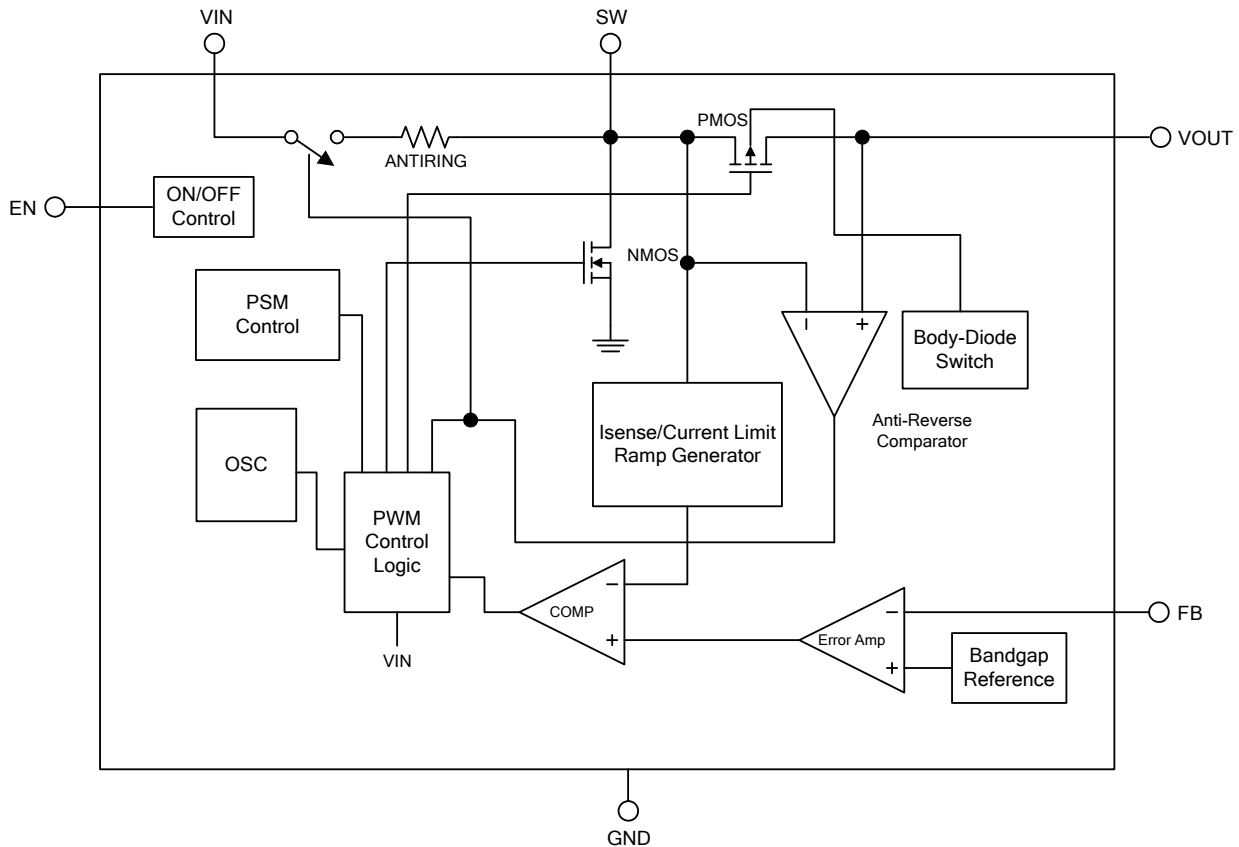

Figure 3. Block Diagram of FP6714

Absolute Maximum Ratings

- Supply Input Voltage (VIN ,VOUT, EN, FB) ----- -0.3V to +4V
- SW Voltage (SW) ----- -0.3V to +4V
- Power Dissipation @T_A=25°C, SOT-23-6/TSOT-23-6 (P_D) ----- +0.50W
- Package Thermal Resistance, SOT-23-6/TSOT-23-6 (θ_{JA}) ----- +250°C/W
- Maximum Junction Temperature (T_J) ----- +150°C
- Storage Temperature Range (T_S) ----- -65°C to +150°C
- Lead Temperature (Soldering, 10 sec.) (T_{LEAD}) ----- +260°C

Note 1 : Stresses beyond those listed under "Absolute Maximum Ratings" may cause permanent damage to the device.

Recommended Operating Conditions

- Input Voltage (V_{IN}) ----- +0.85V to V_{OUT}
- Operating Temperature Range (T_{OPR}) ----- -40°C to +85°C

Electrical Characteristics

($V_{IN}=1.2V$, $EN=V_{IN}$, $T_A=25^{\circ}C$, unless otherwise specified)

| Parameter | Symbol | Conditions | Min | Typ | Max | Unit |
|--------------------------------------|-------------------|---|---------------------|------|---------------------|-------------|
| Start-up Voltage | V_{ST} | $I_{OUT}=1mA$ | | 0.85 | | V |
| Output Voltage Range | V_{OUT} | $I_{OUT}=1mA$ | 1.8 | | 3.8 | V |
| Quiescent Current (No Switching) | I_Q | $V_{FB}>0.7V$ | | 25 | 40 | μA |
| Switch Current Limit (Note 2) | I_{LIM} | $V_{OUT}=3.3V$ | | 0.75 | | A |
| Feedback Voltage | V_{FB} | | 490 | 500 | 510 | mV |
| Oscillation Frequency | f_{OSC} | | 800 | 1000 | 1250 | kHz |
| Maximum Duty Cycle | D_{MAX} | | | 85 | | % |
| NMOS Switch ON Resistance (Note 2) | $R_{DS(ON)}$ | $V_{OUT}=3.3V$ | | 0.25 | | Ω |
| PMOS Switch ON Resistance (Note 2) | $R_{DS(ON)}$ | $V_{OUT}=3.3V$ | | 0.35 | | Ω |
| Line Regulation | ΔV_{LINE} | $V_{IN}=1.8V$ to $2.4V$, $I_{OUT}=100mA$ | | 0.2 | | % |
| Load Regulation | ΔV_{LOAD} | $V_{IN}=1.8V$, $I_{OUT}=50\sim 100mA$ | | 0.35 | | % |
| FB Input Bias Current | $I_{(FB)}$ | | | 0.1 | 1 | μA |
| EN Input Low Voltage | V_{IL} | $0.8V < V_{IN} < 4V$ | | | $V_{IN} \times 0.1$ | V |
| EN Input High Voltage | V_{IH} | $0.8V < V_{IN} < 4V$ | $V_{IN} \times 0.9$ | | | V |
| EN Input Current | | $EN=GND$ or V_{IN} | | 0.1 | 1 | μA |
| Under Voltage Lockout Voltage | V_{UVLO} | V_{IN} Falling | | 0.52 | | V |
| Shutdown Current from Power Source | I_{OFF} | $EN=0V$ | | 1 | 5 | μA |
| Over-Temperature Protection (Note 2) | T_{SD} | | | 160 | | $^{\circ}C$ |
| | ΔT_{SD} | Hysteresis | | 20 | | $^{\circ}C$ |

Note 2 : The specification is guaranteed by design, not production tested.

Typical Performance Curves

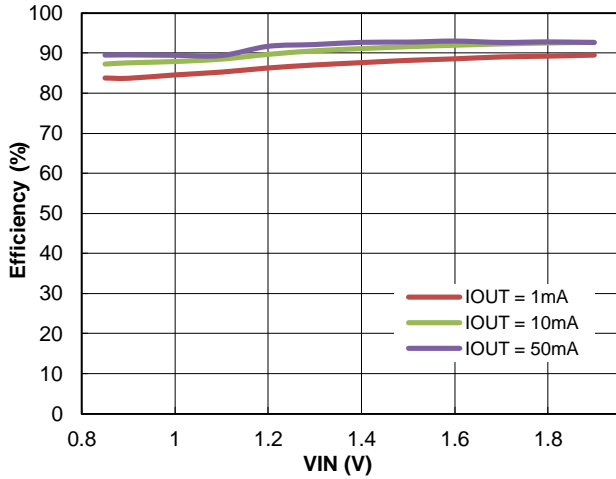

Figure 4. Efficiency vs. Input Voltage ($V_{OUT}=2.2V$)

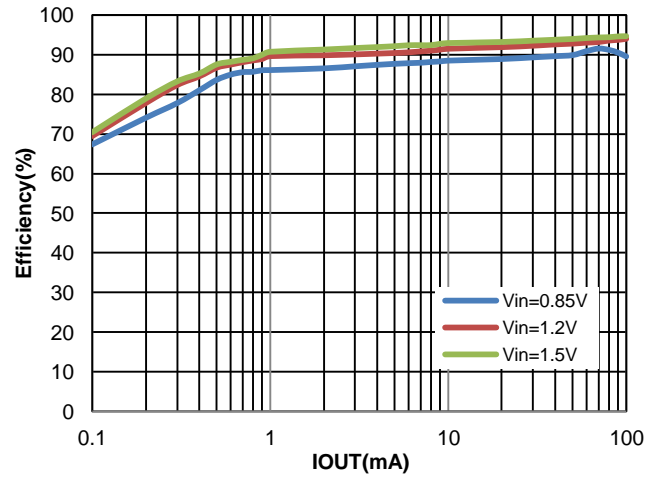

Figure 5. Efficiency vs. Output Current ($V_{OUT}=2.2V$)

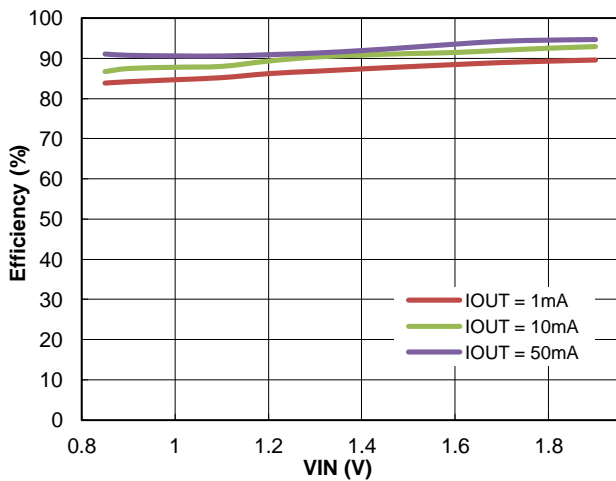

Figure 6. Efficiency vs. Input Voltage ($V_{OUT}=2.8V$)

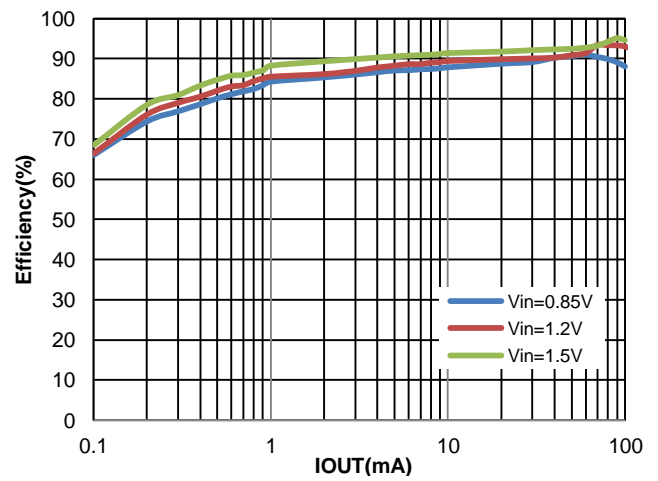

Figure 7. Efficiency vs. Output Current ($V_{OUT}=2.8V$)

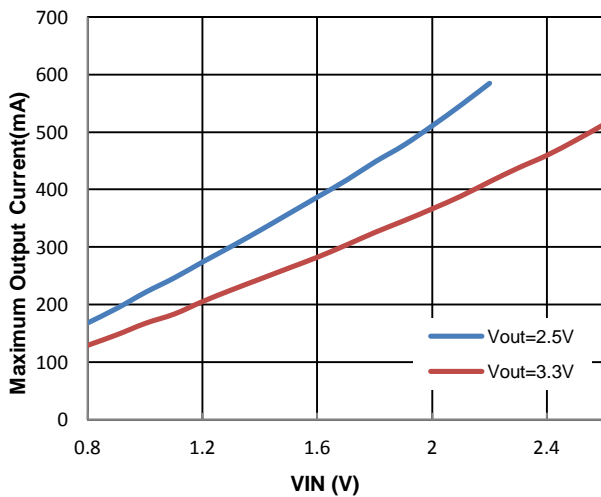

Figure 8. Maximum Output Current vs. Input Voltage

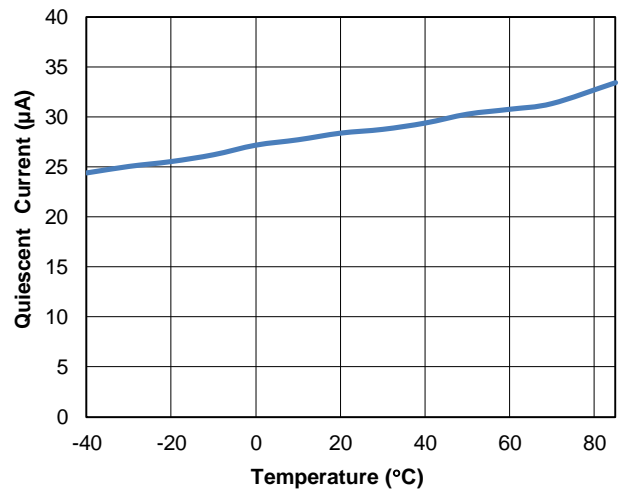

Figure 9. Quiescent Current vs. Temperature

Typical Performance Curves (Continued)

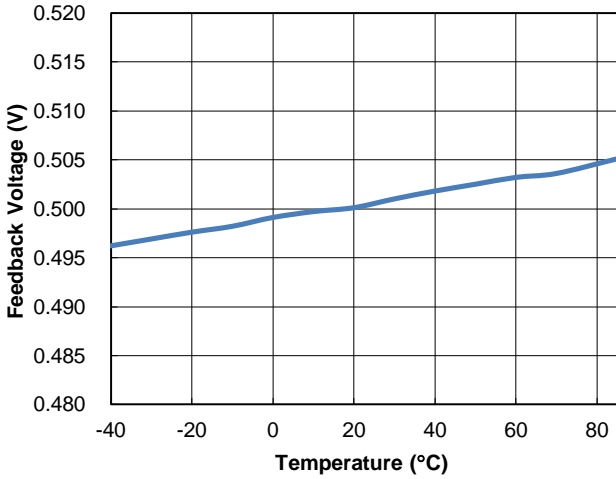

Figure 10. Feedback Voltage vs. Temperature

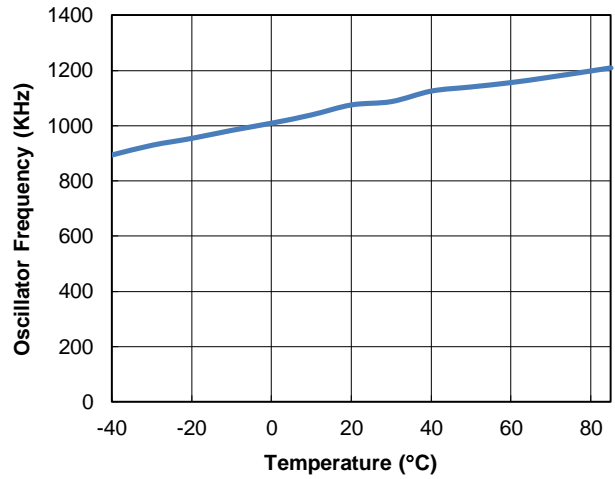

Figure 11. Oscillator Frequency vs. Temperature

$V_{IN}=2.5V, V_{OUT}=3.3V, I_{OUT}=60mA$

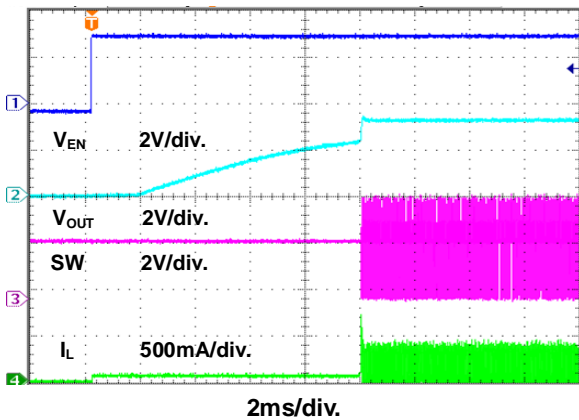

Figure 12. Power On through EN Waveform

$V_{IN}=2.5V, V_{OUT}=3.3V, I_{OUT}=60mA$

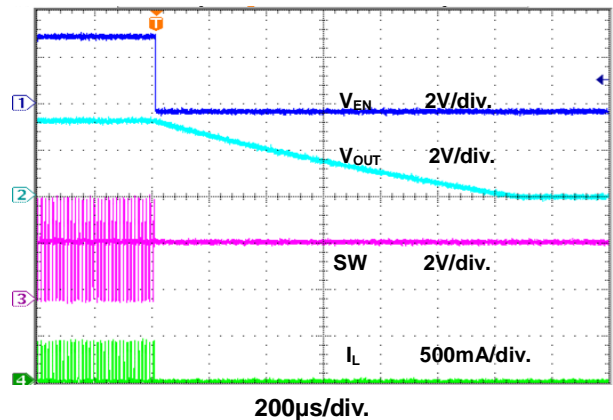

Figure 13. Power Off through EN Waveform

$V_{IN}=1.2V, V_{OUT}=3.3V, I_{OUT}=100mA$

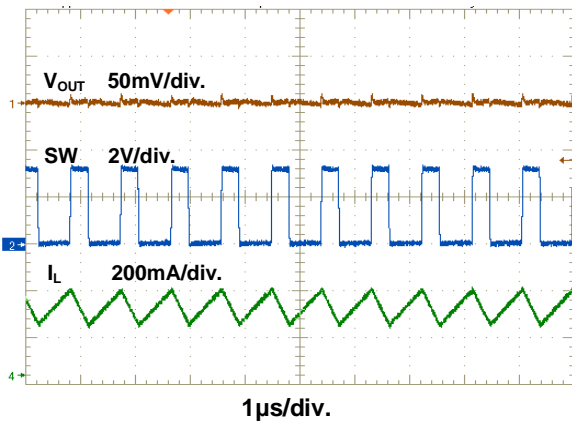

Figure 14. Switching Waveform

$V_{IN}=1.8V, V_{OUT}=3.3V, I_{OUT}=80mA$

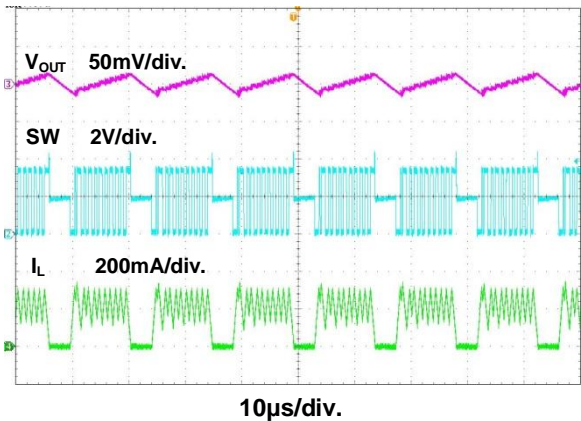

Figure 15. Switching Waveform

Typical Performance Curves (Continued)

$V_{IN}=1.5V$, $V_{OUT}=3.3V$, $I_{OUT}=100mA \rightarrow 150mA$

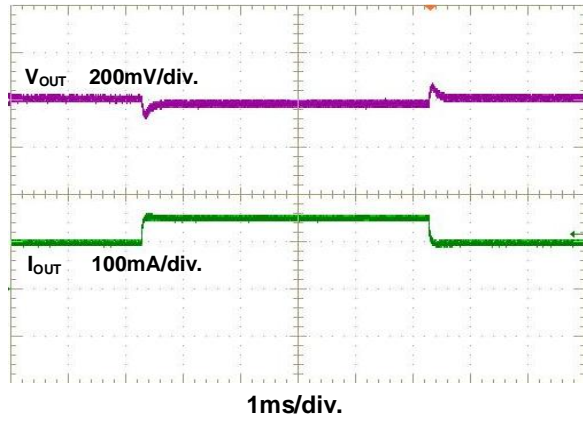

Figure 16. Load Transient Response

$V_{IN}=1.2V$, $V_{OUT}=3.3V$, $I_{OUT}=10mA \rightarrow 100mA$, PSM \rightarrow PWM

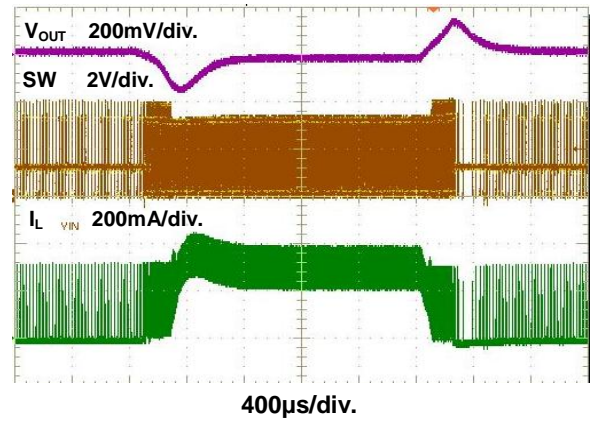

Figure 17. Load Transient Response

Application Information

Controller Circuit

The device is based on a current-mode control topology and uses a constant frequency pulse-width modulator to regulate the output voltage. The controller limits the current through the power switch on a pulse by pulse basis. The current sensing circuit is integrated in the device; therefore, no additional components are required. Due to the nature of the boost converter topology used here, the peak switch current is the same as the peak inductor current, which will be limited by the integrated current limiting circuits under normal operating conditions.

Synchronous Rectifier

The device integrates an N-channel and a P-channel MOSFET transistor to realize a synchronous rectifier. There is no additional Schottky diode required. Because the device uses an integrated low $R_{DS(ON)}$ PMOS switch for rectification, the power conversion efficiency reaches 94%.

A special circuit is applied to disconnect the load from the input during shutdown of the converter. In conventional synchronous rectifier circuits, the backgate diode of the high-side PMOS is forward biased in shutdown and allows current flowing from the battery to the output. This device, however, uses a special circuit to disconnect the backgate diode of the high-side PMOS and so, disconnects the output circuitry from the source when the regulator is not enabled (EN = low).

PSM Mode

The FP6714 is designed for high efficiency over wide output current range. Even at light load, the efficiency stays high because the switching losses of the converter are minimized by effectively reducing the switching frequency. The controller will enter a power saving mode if certain conditions are met. In this mode, the controller only switches on the transistor if the output voltage trips below a set threshold voltage. It ramps up the output voltage with one or several pulses, and goes again into PSM mode once the output voltage exceeds a set threshold voltage.

Device Enable

The device will be shut down when EN is set to GND. In this mode, the regulator stops switching, all internal control circuitry including the low-battery comparator will be switched off, and the load will be disconnected from the input (as described in above synchronous rectifier section). This also means that the output voltage may drop below the input voltage during shutdown.

The device is put into operation when EN is set high. During start-up of the converter, the duty cycle is limited in order to avoid high peak currents drawn from the battery. The limit is set internally by the current limit circuit.

Anti-Ringing Switch

The device integrates a circuit which removes the ringing that typically appears on the SW node when the converter enters the discontinuous current mode. In this case, the current through the inductor ramps to zero and the integrated PMOS switch turns off to prevent a reverse current from the output capacitors back to the battery. Due to remaining energy that is stored in parasitic components of the semiconductors and the inductor, a ringing on the SW pin is induced. The integrated anti-ringing switch clamps this voltage internally to V_{IN} ; therefore, dampens this ringing.

Adjustable Output Voltage

The accuracy of the output voltage is determined by the accuracy of the internal voltage reference, the controller topology, and the accuracy of the external resistor. The reference voltage has an accuracy of $\pm 2\%$. The controller switches between fixed frequency and PSM mode, depending on load current. The tolerance of the resistors in the feedback divider determines the total system accuracy.

Design Procedure

The FP6714 boost converter family is intended for systems that are powered by a single-cell NiCd or NiMH battery with a typical terminal voltage between 0.9V to 1.6V. It can also be used in systems that are powered by two-cell NiCd or NiMH batteries with a typical stack voltage between 1.8V to 3.2V. Additionally, single or dual-cell, primary and secondary alkaline battery cells can be the power source in systems where the FP6714 is used.

Application Information (Continued)

(1) Programming the Output Voltage

The output voltage of the FP6714 can be adjusted with an external resistor divider. The typical value of the voltage on the FB pin is 500mV in fixed frequency operation. The maximum allowed value for the output voltage is 3.8V. The current through the resistive divider should be about 100 times greater than the current into the FB pin. The typical current into the FB pin is 0.01μA, and the voltage across R2 is typically 500mV. Based on those two values, the recommended value for R2 is in the range of 500kΩ in order to set the divider current at 1μA. From that, the value of resistor R1, depending on the needed output voltage (V_o), can be calculated using Equation 1.

$$R1=R2 \times \left(\frac{V_{OUT}}{V_{FB}} - 1 \right) = 500k\Omega \times \left(\frac{V_{OUT}}{500mV} - 1 \right) \dots\dots(1)$$

(2) Inductor Selection

A boost converter normally requires two main passive components for storing energy during the conversion. A boost inductor is required and a storage capacitor at the output. To select the boost inductor, it is recommended to keep the possible peak inductor current below the current limit threshold of the power switch in the chosen configuration.

The second parameter for choosing the inductor is the desired current ripple in the inductor. Normally, it is advisable to work with a ripple of less than 20% of the average inductor current. A smaller ripple reduces the magnetic hysteresis losses in the inductor, as well as output voltage ripple and EMI. But in the same way, regulation time at load changes rises. In addition, a larger inductor increases the total system cost. With those parameters, it is possible to calculate the value for the inductor by using Equation 2.

$$L = \frac{V_{IN} \times (V_{OUT} - V_{IN})}{\Delta I_L \times f \times V_{OUT}} \dots\dots(2)$$

Parameter f is the switching frequency and ΔI_L is the ripple current in the inductor, i.e., 20% x I_L . With this calculated value and currents, it is possible to choose a suitable inductor. Care must be taken that load transients and losses in the circuit can lead to higher currents. Also, the losses in the inductor caused by magnetic hysteresis losses and copper losses are a major parameter for total circuit efficiency.

(3) Capacitor Selection

The major parameter necessary to define the output capacitor is the maximum allowed output voltage ripple of the converter. This ripple is determined by two parameters of the capacitor, the capacitance and the ESR. It is possible to calculate the minimum capacitance needed for the defined ripple, supposing that the ESR is zero, by using Equation 3.

$$C_{MIN} = \frac{I_{OUT} \times (V_{OUT} - V_{IN})}{f \times \Delta V \times V_{OUT}} \dots\dots(3)$$

Parameter f is the switching frequency and ΔV is the maximum allowed ripple.

The total ripple is larger due to the ESR of the output capacitor. This additional component of the ripple can be calculated using Equation 4.

$$\Delta V_{ESR} = I_{OUT} \times R_{ESR} \dots\dots(4)$$

The total ripple is the sum of the ripple caused by the capacitance and the ripple caused by the ESR of the capacitor. It is possible to improve the design by enlarging the capacitor or using smaller capacitors in parallel to reduce the ESR or by using better capacitors with lower ESR, like ceramics. Tradeoffs must be made between performance and costs of the converter circuit.

A 10μF input capacitor is recommended to improve transient behavior of the regulator. A ceramic or tantalum capacitor with a 100nF in parallel placed close to the IC is recommended.

Thermal Information

The maximum junction temperature (T_J) of the FP6714 devices is recommended to 150°C. The thermal resistance of the SOT-23-6/TSOT-23-6 package is $\theta_{JA} = 250^\circ\text{C/W}$. Specified regulator operations are assured to ambient temperature (T_A) of 25°C. Therefore, the maximum power dissipation is about 500mW. More power can be dissipated if the maximum ambient temperature of the application is lower.

$$P_{D(MAX)} = \frac{T_{J(MAX)} - T_A}{\theta_{JA}} = \frac{150^\circ\text{C} - 25^\circ\text{C}}{250^\circ\text{C/W}} = 500\text{mW}$$

Application Information (Continued)

Layout Considerations

As for all switching power supplies, the layout is an important step in the design, especially at high peak currents and high switching frequencies. If the layout is not carefully done, the regulator could show stability problems as well as EMI problems. Therefore, use wide and short traces for the main current path as indicated in bold in Figure 18. The input capacitor, output capacitor and the inductor should be placed as close to the IC as possible. Use a common ground node as shown in Figure 18 to minimize the effects of ground noise. The feedback divider should be placed as close to the IC as possible.

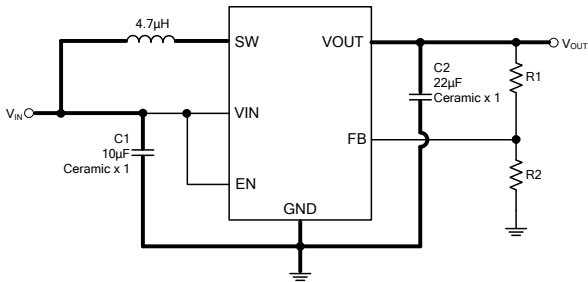
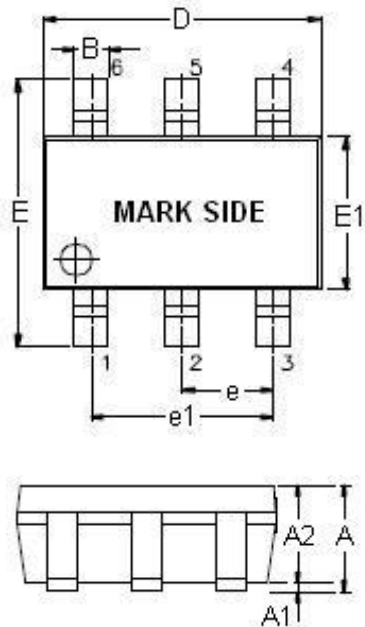

Figure 18. Layout Diagram

Outline Information

SOT-23-6 Package (Unit: mm)



| SYMBOLS UNIT | DIMENSION IN MILLIMETER | |
|-----------------|-------------------------|------|
| | MIN | MAX |
| A | 0.90 | 1.45 |
| A1 | 0.00 | 0.15 |
| A2 | 0.90 | 1.30 |
| B | 0.30 | 0.50 |
| D | 2.80 | 3.00 |
| E | 2.60 | 3.00 |
| E1 | 1.50 | 1.70 |
| e | 0.90 | 1.00 |
| e1 | 1.80 | 2.00 |
| L | 0.30 | 0.60 |

Note : Followed From JEDEC MO-178-C.

Carrier Dimensions

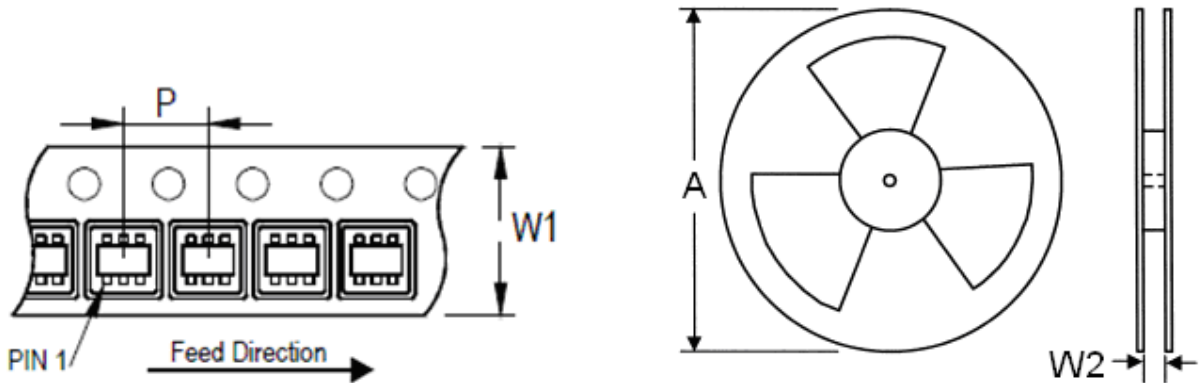

| Tape Size (W1) mm | Pocket Pitch (P) mm | Reel Size (A) | | Reel Width (W2) mm | Empty Cavity Length mm | Units per Reel |
|----------------------|------------------------|---------------|-----|-----------------------|---------------------------|----------------|
| | | in | mm | | | |
| 8 | 4 | 7 | 180 | 8.4 | 300~1000 | 3,000 |

Outline Information (Continued)

TSOT-23-6 Package (Unit: mm)

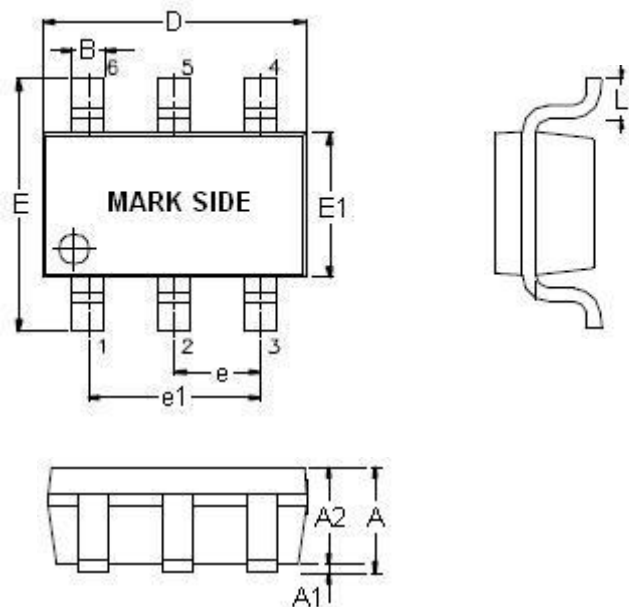

| SYMBOLS UNIT | DIMENSION IN MILLIMETER | |
|-----------------|-------------------------|------|
| | MIN | MAX |
| A | 0.70 | 0.90 |
| A1 | 0.00 | 0.10 |
| A2 | 0.70 | 1.00 |
| B | 0.30 | 0.50 |
| D | 2.80 | 3.00 |
| E | 2.60 | 3.00 |
| E1 | 1.50 | 1.70 |
| e | 0.90 | 1.00 |
| e1 | 1.80 | 2.00 |
| L | 0.30 | 0.60 |

Carrier Dimensions

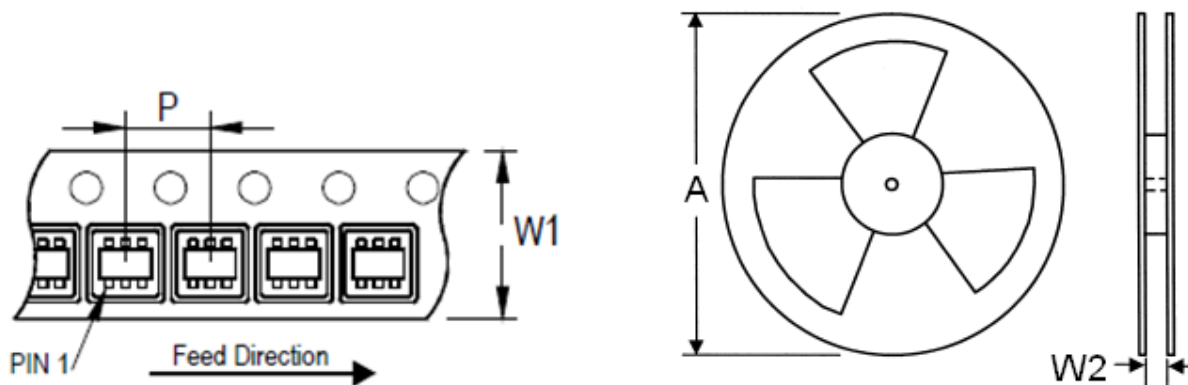

| Tape Size (W1) mm | Pocket Pitch (P) mm | Reel Size (A) | | Reel Width (W2) mm | Empty Cavity Length mm | Units per Reel |
|----------------------|------------------------|---------------|-----|-----------------------|---------------------------|----------------|
| | | in | mm | | | |
| 8 | 4 | 7 | 180 | 8.4 | 300~1000 | 3,000 |

Life Support Policy

Fitipower's products are not authorized for use as critical components in life support devices or other medical systems.

X-ON Electronics

Largest Supplier of Electrical and Electronic Components

Click to view similar products for [Isolated DC/DC Converters](#) category:

Click to view products by [Fitipower](#) manufacturer:

Other Similar products are found below :

[ESM6D044440C05AAQ](#) [FMD15.24G](#) [PSL486-7LR](#) [PSR152.5-7IR](#) [Q48T30020-NBB0](#) [AVO240-48S12B-6L](#) [AVO250-48S28B-6L](#) [NAN-0505](#) [HW-L16D](#) [JAHW100Y1](#) [217-1617-001](#) [22827](#) [SPB05C-12](#) [SQ24S15033-PS0S](#) [18952](#) [19-130041](#) [CE-1003](#) [CE-1004](#) [GQ2541-7R](#) [PSE1000DCDC-12V](#) [RDS180245](#) [MAU228](#) [419-2065-201](#) [449-2075-101](#) [TME 0303S](#) [TME 0505S](#) [TME 1205S](#) [TME 1212S](#) [TME 2405S](#) [TME 2412S](#) [J80-0041NL](#) [V300C24C150BG](#) [419-2062-200](#) [419-2063-401](#) [419-2067-101](#) [419-2067-501](#) [419-2068-001](#) [DCG40-5G](#) [DFC15U48D15](#) [449-2067-000](#) [XGS-0512](#) [XGS-1205](#) [XGS-1212](#) [XGS-2412](#) [XGS-2415](#) [XKS-1215](#) [033456](#) [NCT1000N040R050B](#) [SPB05B-15](#) [SPB05C-15](#)