

## 350KHZ Zero-Drift CMOS Rail-to-Rail IO Opamp with RF Filter

### Features

- Single-Supply Operation from +1.8V ~ +5.5V
- Rail-to-Rail Input / Output
- Gain-Bandwidth Product: 350KHz (Typ. @25°C)
- Low Input Bias Current: 20pA (Typ. @25°C)
- Low Offset Voltage: 10uV (Max. @25°C)
- Quiescent Current: 25µA per Amplifier (Typ)
- Operating Temperature: -45°C ~ +125°C
- Zero Drift: 0.05µV/°C (Typ)
- Embedded RF Anti-EMI Filter
- Small Package:  
OPA317 Available in SOT23-5, SC70-5 and SOP-8 Packages  
OPA2317 Available in SOP-8, MSOP-8 and DFN-8 Packages  
OPA4317 Available in SOP-14 and TSSOP-14 Packages

### General Description

The OPAX317 amplifier is single/dual/quad supply, micro-power, zero-drift CMOS operational amplifiers, the amplifiers offer bandwidth of 350 kHz, rail-to-rail inputs and outputs, and single-supply operation from 1.8V to 5.5V. OPAX317 uses chopper stabilized technique to provide very low offset voltage (less than 10µV maximum) and near zero drift over temperature. Low quiescent supply current of 25µA per amplifier and very low input bias current of 20pA make the devices an ideal choice for low offset, low power consumption and high impedance applications.

The OPA317 is available in SOT23-5, SC70-5 and SOP8 packages. And the OPA2317 is available in SOP8, MSOP8 and DFN-8 packages. The OPA4317 Quad is available in Green SOP-14 and TSSOP-14 packages. The extended temperature range of -45°C to +125°C over all supply voltages offers additional design flexibility.

### Applications

- Transducer Application
- Temperature Measurements
- Electronics Scales
- Handheld Test Equipment
- Battery-Powered Instrumentation

### Pin Configuration

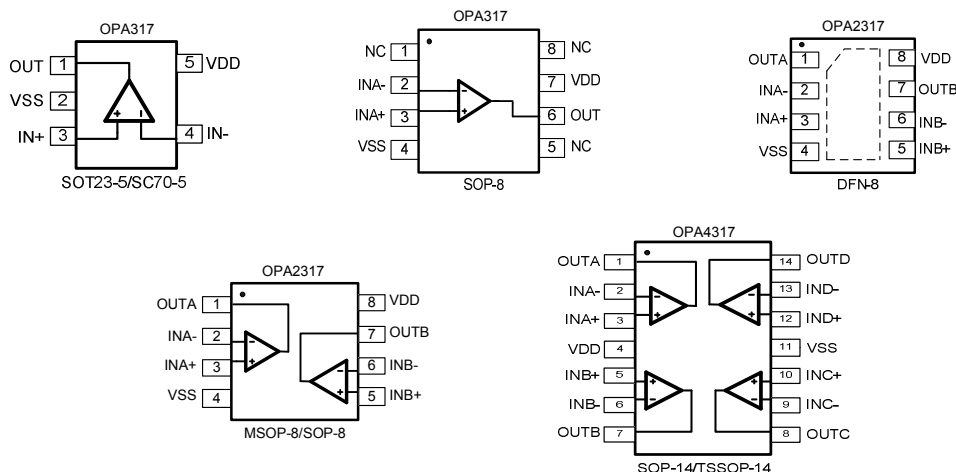

Figure 1. Pin Assignment Diagram

**Absolute Maximum Ratings**

Condition	Min	Max
Power Supply Voltage ( $V_{DD}$ to $V_{SS}$ )	-0.5V	+7.5V
Analog Input Voltage (IN+ or IN-)	$V_{SS}-0.5V$	$V_{DD}+0.5V$
PDB Input Voltage	$V_{SS}-0.5V$	+7V
Operating Temperature Range	-45°C	+125°C
Junction Temperature	+160°C	
Storage Temperature Range	-55°C	+150°C
Lead Temperature (soldering, 10sec)	+260°C	
<b>Package Thermal Resistance (<math>T_A=+25^\circ\text{C}</math>)</b>		
SOP-8, $\theta_{JA}$	125°C/W	
MSOP-8, $\theta_{JA}$	216°C/W	
SOT23-5, $\theta_{JA}$	190°C/W	
<b>ESD Susceptibility</b>		
HBM	6KV	
MM	400V	

**Note:** Stress greater than those listed under Absolute Maximum Ratings may cause permanent damage to the device. This is a stress rating only and functional operation of the device at these or any other conditions outside those indicated in the operational sections of this specification are not implied. Exposure to absolute maximum rating conditions for extended periods may affect reliability.

## Electrical Characteristics

(At  $V_S=5V$ ,  $T_A = +25^\circ C$ ,  $V_{CM} = V_S/2$ ,  $R_L = 10k\Omega$ , unless otherwise noted.)

PARAMETER	CONDITIONS	MIN	TYP	MAX	UNITS
<b>INPUT CHARACTERISTICS</b>					
Input Offset Voltage ( $V_{OS}$ )			2	10	$\mu V$
Input Bias Current ( $I_B$ )			20		pA
Input Offset Current ( $I_{OS}$ )			10		pA
Common-Mode Rejection Ratio (CMRR)	$V_{CM} = 0V$ to $5V$		110		dB
Large Signal Voltage Gain ( $A_{VO}$ )	$R_L = 10k\Omega$ , $V_O = 0.3V$ to $4.7V$		145		dB
Input Offset Voltage Drift ( $\Delta V_{OS}/\Delta T$ )			50		nV/ $^\circ C$
<b>OUTPUT CHARACTERISTICS</b>					
Output Voltage High ( $V_{OH}$ )	$R_L = 100k\Omega$ to $-V_S$		4.998		V
	$R_L = 10k\Omega$ to $-V_S$		4.994		V
Output Voltage Low ( $V_{OL}$ )	$R_L = 100k\Omega$ to $+V_S$		5		mV
	$R_L = 10k\Omega$ to $+V_S$		20		mV
Short Circuit Limit ( $I_{SC}$ )	$R_L = 10\Omega$ to $-V_S$		20		mA
Output Current ( $I_O$ )			30		mA
<b>POWER SUPPLY</b>					
Power Supply Rejection Ratio (PSRR)	$V_S = 2.5V$ to $5.5V$		115		dB
Quiescent Current ( $I_Q$ )	$V_O = 0V$ , $R_L = 0\Omega$		25		$\mu A$
<b>DYNAMIC PERFORMANCE</b>					
Gain-Bandwidth Product (GBP)	$G = +100$		350		KHz
Slew Rate (SR)	$R_L = 10k\Omega$		0.2		V/ $\mu s$
<b>NOISE PERFORMANCE</b>					
Voltage Noise ( $e_n$ p-p)	0Hz to 10Hz		1.1		$\mu V_{P-P}$
Voltage Noise Density ( $e_n$ )	$f = 1kHz$		70		nV/ $\sqrt{Hz}$

## Typical Performance characteristics

( $T_A=+25^\circ\text{C}$ ,  $V_S=5\text{V}$ ,  $R_L=10\text{ k}\Omega$  connected to  $V_S/2$  and  $V_{OUT}=V_S/2$ , unless otherwise noted.)

Large Signal Transient Response

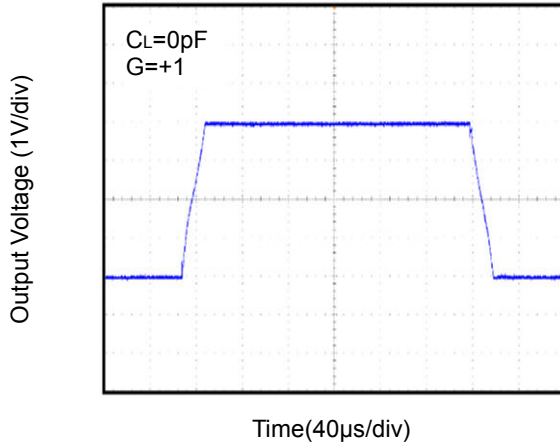

Large Signal Transient Response

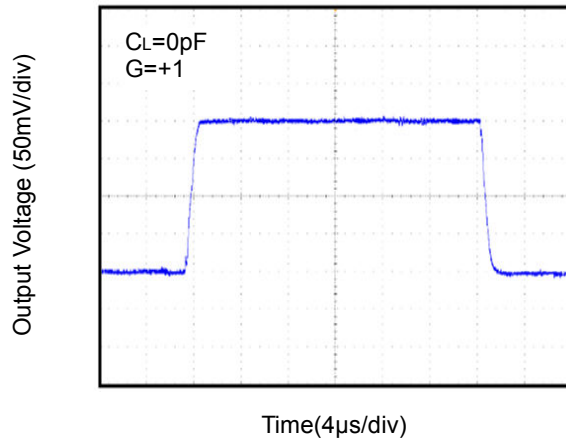

Positive Overvoltage Recovery

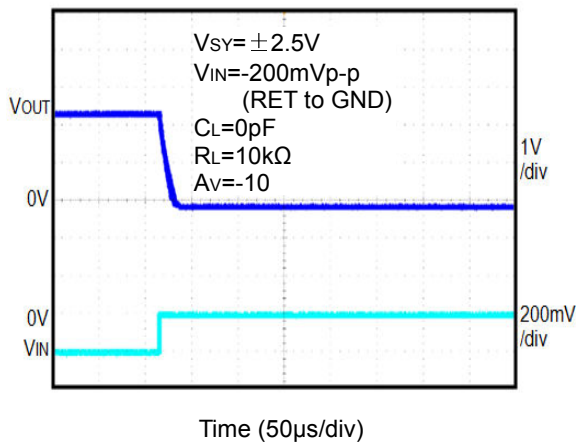

Negative Overvoltage Recovery

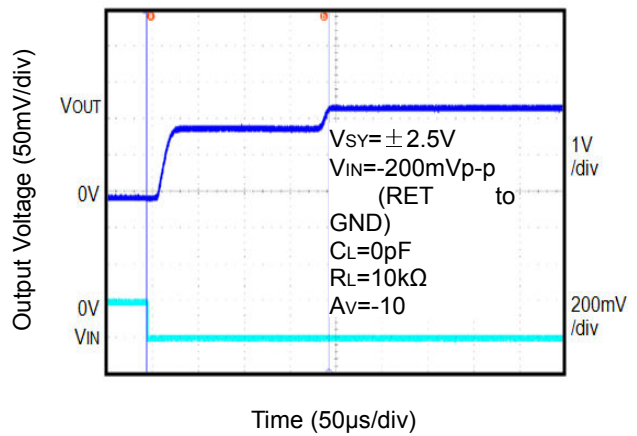

Open Loop Gain, Phase Shift vs. Frequency

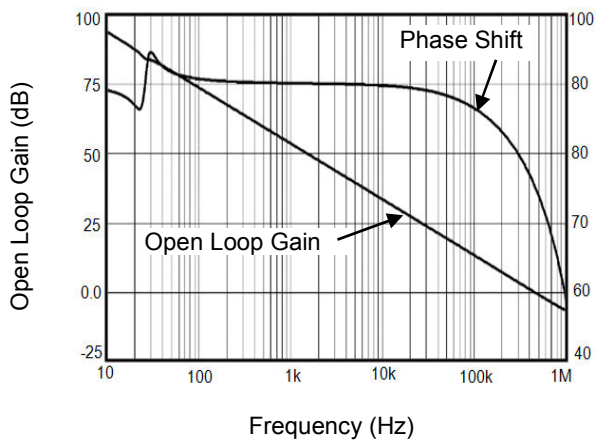

Supply Current vs. Temperature

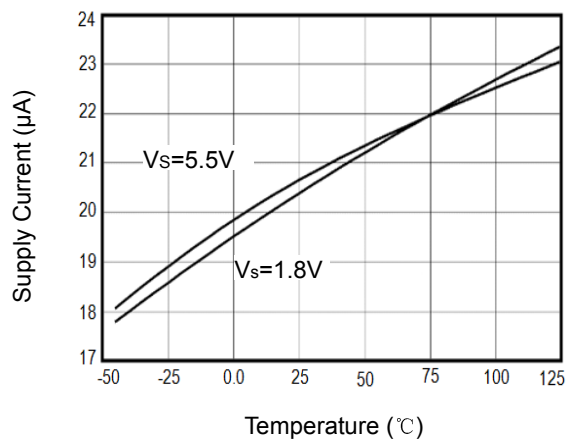

**Typical Performance characteristics**

( $T_A=+25^\circ\text{C}$ ,  $V_S=5\text{V}$ ,  $R_L=10\text{ k}\Omega$  connected to  $V_S/2$  and  $V_{OUT}=V_S/2$ , unless otherwise noted.)

Output Voltage Swing vs. Output Current at +3V

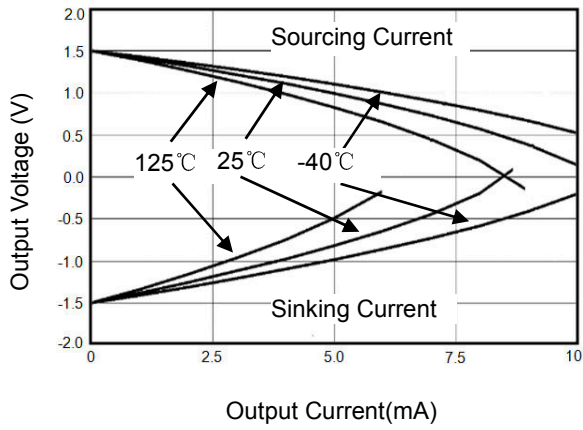

Output Voltage Swing vs. Output Current at +5V

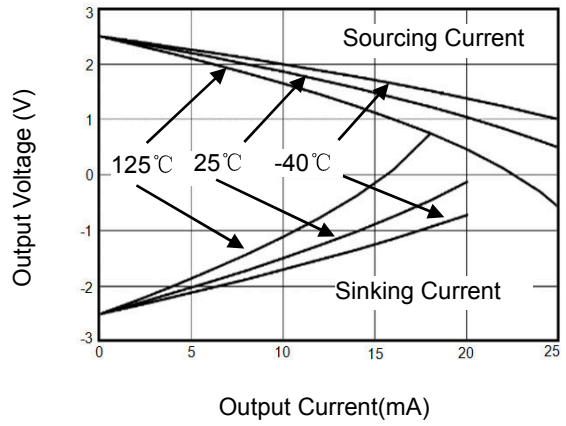

## Application Note

### Size

OPAx317 series op amps are unity-gain stable and suitable for a wide range of general-purpose applications. The small footprints of the OPAx317 series packages save space on printed circuit boards and enable the design of smaller electronic products.

### Power Supply Bypassing and Board Layout

OPAx317 series operates from a single 1.8V to 5.5V supply or dual  $\pm 0.9V$  to  $\pm 2.75V$  supplies. For best performance, a  $0.1\mu F$  ceramic capacitor should be placed close to the  $V_{DD}$  pin in single supply operation. For dual supply operation, both  $V_{DD}$  and  $V_{SS}$  supplies should be bypassed to ground with separate  $0.1\mu F$  ceramic capacitors.

### Low Supply Current

The low supply current (typical 25uA per channel) of OPAx317 series will help to maximize battery life. They are ideal for battery powered systems

### Operating Voltage

OPAx317 series operate under wide input supply voltage (1.8V to 5.5V). In addition, all temperature specifications apply from  $-45^{\circ}C$  to  $+125^{\circ}C$ . Most behavior remains unchanged throughout the full operating voltage range. These guarantees ensure operation throughout the single Li-Ion battery lifetime

### Rail-to-Rail Input

The input common-mode range of OPAx317 series extends 100mV beyond the supply rails ( $V_{SS}-0.1V$  to  $V_{DD}+0.1V$ ). This is achieved by using complementary input stage. For normal operation, inputs should be limited to this range.

### Rail-to-Rail Output

Rail-to-Rail output swing provides maximum possible dynamic range at the output. This is particularly important when operating in low supply voltages. The output voltage of OPAx317 series can typically swing to less than 5mV from supply rail in light resistive loads ( $>100k\Omega$ ), and 100mV of supply rail in moderate resistive loads (10k $\Omega$ ).

### Capacitive Load Tolerance

The OPAx317 family is optimized for bandwidth and speed, not for driving capacitive loads. Output capacitance will create a pole in the amplifier's feedback path, leading to excessive peaking and potential oscillation. If dealing with load capacitance is a requirement of the application, the two strategies to consider are (1) using a small resistor in series with the amplifier's output and the load capacitance and (2) reducing the bandwidth of the amplifier's feedback loop by increasing the overall noise gain. Figure 2. shows a unity gain follower using the series resistor strategy. The resistor isolates the output from the capacitance and, more importantly, creates a zero in the feedback path that compensates for the pole created by the output capacitance.

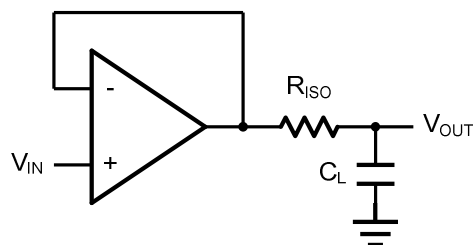

Figure 2. Indirectly Driving a Capacitive Load Using Isolation Resistor

The bigger the  $R_{ISO}$  resistor value, the more stable  $V_{OUT}$  will be. However, if there is a resistive load  $R_L$  in parallel with the capacitive load, a voltage divider (proportional to  $R_{ISO}/R_L$ ) is formed, this will result in a gain error.

The circuit in Figure 3 is an improvement to the one in Figure 2.  $R_F$  provides the DC accuracy by feed-forward the  $V_{IN}$  to  $R_L$ .  $C_F$

and  $R_{ISO}$  serve to counteract the loss of phase margin by feeding the high frequency component of the output signal back to the amplifier's inverting input, thereby preserving the phase margin in the overall feedback loop. Capacitive drive can be increased by increasing the value of  $C_F$ . This in turn will slow down the pulse response.

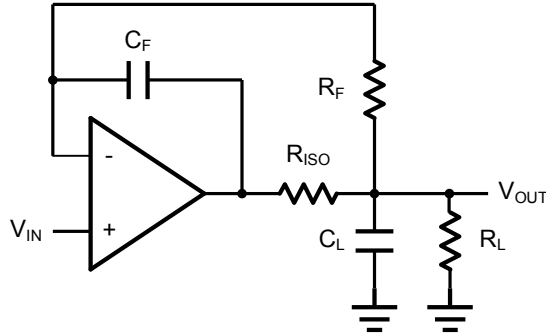

Figure 3. Indirectly Driving a Capacitive Load with DC Accuracy

## Typical Application Circuits

### Differential amplifier

The differential amplifier allows the subtraction of two input voltages or cancellation of a signal common to the two inputs. It is useful as a computational amplifier in making a differential to single-end conversion or in rejecting a common mode signal. Figure 4. shows the differential amplifier using OPAx317.

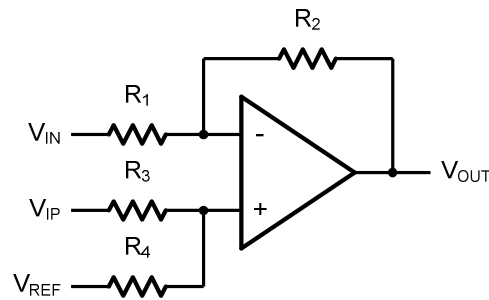

Figure 4. Differential Amplifier

$$V_{OUT} = \left(\frac{R_1+R_2}{R_3+R_4}\right) \frac{R_4}{R_1} V_{IN} - \frac{R_2}{R_1} V_{IP} + \left(\frac{R_1+R_2}{R_3+R_4}\right) \frac{R_3}{R_1} V_{REF}$$

If the resistor ratios are equal (i.e.  $R_1=R_3$  and  $R_2=R_4$ ), then

$$V_{OUT} = \frac{R_2}{R_1} (V_{IP} - V_{IN}) + V_{REF}$$

### Low Pass Active Filter

The low pass active filter is shown in Figure 5. The DC gain is defined by  $-R_2/R_1$ . The filter has a -20dB/decade roll-off after its corner frequency  $f_c=1/(2\pi R_3 C_1)$ .

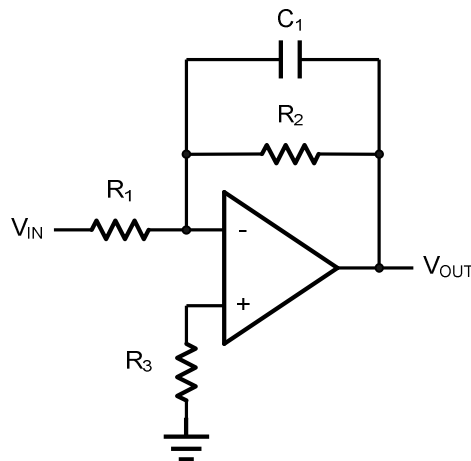

Figure 5. Low Pass Active Filter



### Instrumentation Amplifier

The triple OPAX317 can be used to build a three-op-amp instrumentation amplifier as shown in Figure 6. The amplifier in Figure 6 is a high input impedance differential amplifier with gain of  $R_2/R_1$ . The two differential voltage followers assure the high input impedance of the amplifier.

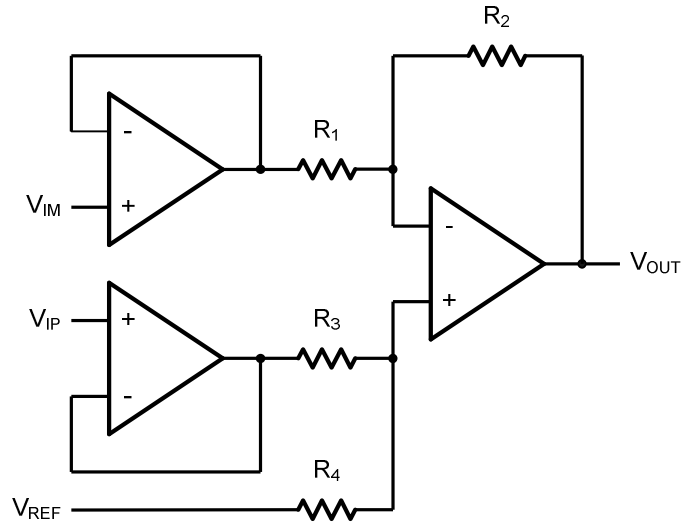

Figure 6. Instrument Amplifier

## X-ON Electronics

Largest Supplier of Electrical and Electronic Components

*Click to view similar products for [Precision Amplifiers](#) category:*

*Click to view products by [HGSEMI](#) manufacturer:*

Other Similar products are found below :

[OPA4187IRUMT](#) [OPA202IDGKT](#) [514327X](#) [561681F](#) [647876R](#) [5962-9080901MCA\\*](#) [MAX410CPA](#) [MAX44241AUK+T](#) [LT6230IS6#TR](#)  
[LT1112S8#TR](#) [OP227GN#PBF](#) [LT6020IDD-1#PBF](#) [LT6023IDD#PBF](#) [LT6013AIDD#PBF](#) [LT6237IMS8#PBF](#) [LT1124CS8#TR](#)  
[LT1215CS8#TRPBF](#) [ADA4622-1ARZ-R7](#) [NCS21871SQ3T2G](#) [NCS21871SN2T1G](#) [NCV21871SQ3T2G](#) [NCV21871SN2T1G](#)  
[AD8538WAUJZ-R7](#) [NCS21912DMR2G](#) [MCP6V82-EMS](#) [MCP6V92-EMS](#) [TLC27L7CP](#) [TLE2022MD](#) [TLV2473CDR](#) [MCP6V34-E/ST](#)  
[MCP6V84-EST](#) [MCP6V94-EST](#) [LT1014DDWR](#) [5962-89641012A](#) [5962-8859301M2A](#) [5962-89801012A](#) [5962-9452101M2A](#) [LMC6064IN](#)  
[LT1013DDR](#) [TL034ACDR](#) [TLC2201AMDG4](#) [TLC274MDRG4](#) [TLE2021QDRG4Q1](#) [TLE2024BMDWG4](#) [AD8691WAUJZ-R7](#)  
[AD8629TRZ-EP-R7](#) [AD8604ARQZ](#) [TS507IYLT](#) [MAX4239ATT+T](#) [MAX4238AUT+T](#)