



General Description

The SE5220 series of adjustable output ultra low dropout linear regulators are designed for portable battery powered applications, which require low power consumption and low dropout voltage. Each device contains a bandgap voltage reference, an error amplifier, a PMOS power transistor, and current limit and temperature limit protection circuits. The output voltage can be adjusted via the external resistor network, based on the internal reference voltage of 0.8V

The SE5220 is designed to work with low cost electrolytic and ceramic capacitors and requires a minimum output capacitor of 1µF.

Features

- Typical 150mV Dropout Voltage at 500mA.
- Fast Enable Turn-On Time of 20µs (Typ.)
- Excellent Line and Load Regulation.
- High Accuracy Output Voltage of 2%.
- Ultra-Low Ground Current at 78µA(Typ)
- Disable Current Less than 1µA (Typ.)
- Thermal and Over-Current Protection.
- Short Circuit Protection
- Standard SOT23-5 Package.

Applications

- USB removable devices
- MPEG4 devices
- Wireless LAN's
- Hand-Held Instrumentation.
- Portable DVD players
- Digital camera

Typical Application

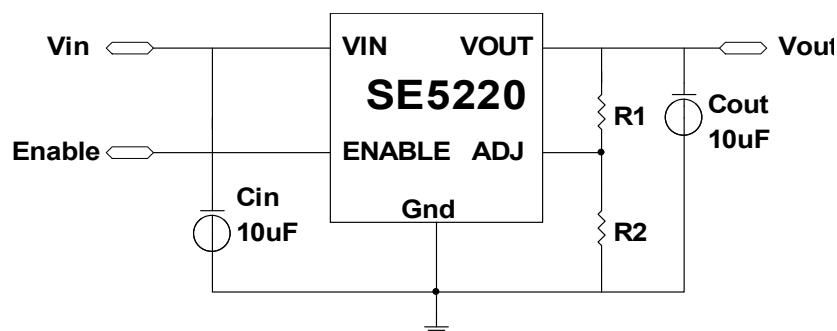

$$V_{out} = 0.8 * (1 + R1/R2) \text{ Volts}$$

Figure 2. ADJ Vout Typical Application Circuit (Minimum Cout 1uF)



Pin Configuration

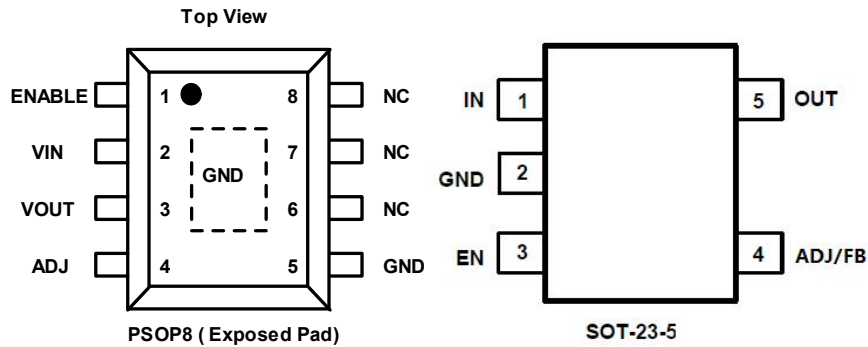

Pin Description

NO.	Pin Name	Pin Function Description
1	ENABLE	Enable Pin
2	VIN	Input Voltage
3	VOUT	Output Voltage
4	ADJ	Adjust Pin
5	GND	Ground

Functional Block Diagram

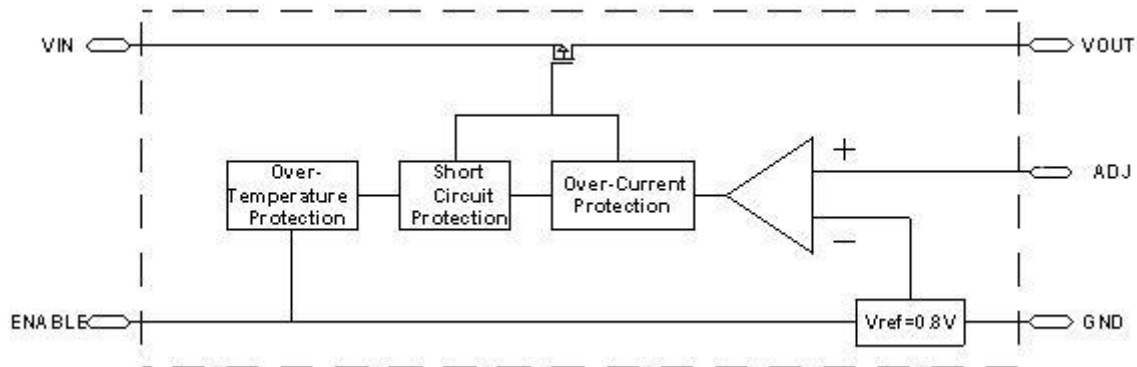

Ordering Information

Part Number	Marking Information	Package	Remarks
SE5220-LF-ADJ	5220X	SOT23-5	Adjustable output voltage X means Production batch.
SE5220-HF-XXV	5220X	SOT23-5	Fixed output voltage 1.0~4.3V X means Production batch.
SE5220-HF-ADJ	SE5220-ADJ YYWW-HF	PSOP8	Adjustable output voltage YYWW means Production batch.



Absolute Maximum Ratings⁽¹⁾

Parameter	Symbol	Value	Units
Input Voltage	V_{IN}	6.5	V
Enable Voltage Range	V_{EN}	-0.3 to V_{IN}	V
Output Voltage Range	V_{OUT}	-0.3 to V_{IN}	V
Power Dissipation	P_D	SOT23-5: 0.7 PSOP8: 1.45	W
Thermal Resistance, Junction-to-Ambient	Θ_{JA}	SOT23-5: 150	°C/W
		PSOP8: 30	
	Θ_{JC}	SOT23-5: 33	
		PSOP8: 20	
Lead Temperature (Soldering, 5 sec.)		260	°C
Junction Temperature Range	T_J	-40 to +150	°C
Storage Temperature Range	T_S	-40 to +150	°C

Test condition for all packages: Device mounted on FR-4 substrate PC board, 1oz copper, with minimum recommended pad layout.

MIL-STD-202G 210F

Recommended Operating Conditions⁽²⁾

Parameter	Symbol	Value	Units
Supply Input Voltage Range	V_{IN}	2~6	V
Junction Temperature Range	T_J	-40 to +125	°C
Ambient Temperature	T_A	-40 to 85	°C

Electrical Characteristics

($V_{IN} = V_{out} + 1.0V$); $C_{IN} = 10\mu F$; $C_{OUT} = 10\mu F$; $I_{OUT} = 10mA$; $T_J = 25^\circ C$; unless otherwise noted)

Symbol	Parameter	Conditions	Min	Typ	Max	Unit
V_{OUT}	Output Voltage Accuracy		-2%		2%	V
V_{REF}	ADJ Pin Voltage	SE5220 – ADJ	-2%	0.8	2%	V
$\Delta V_{OUT}/V_{OUT}$	Line Regulation	$V_{IN} = (V_{OUT} + 0.7)V$ to 6V	--	0.05	0.2	%/V
$\Delta V_{OUT}/V_{OUT}$	Load Regulation ⁽⁵⁾	$V_{IN} = (V_{OUT} + 0.7)V$ $I_{OUT} = 10mA$ to 500mA	--	0.12	1	%
$\Delta V_{OUT}/\Delta T$	Output Voltage Temperature Coefficient	Note 4	--	0.1	--	mV/°C



$V_{IN} - V_{OUT}$	Dropout Voltage (6)	$V_{out} < 2.5V, I_{out} = 600mA$	--	306	550	mV
		$V_{out} \geq 2.5V, I_{out} = 600mA$	--	240	350	
$T_{PROTECTION}$	Thermal Protection	Thermal Protect Threshold	--	150	--	°C
		Hysterisys		30		
I_Q	Quiescent Current	$V_{EN} = V_{IN}; I_{OUT} = 0mA$	--	78	100	μA
		$V_{EN} = 0.4V; I_{OUT} = 0mA$	--	0.1	1	
$V_{TH(EN)}$	Enable Input Threshold Voltage	Voltage Increasing, Output Turns On, Logic High	1.6	--	--	V
		Voltage Decreasing, Output Turns Off, Logic Low	--	--	0.4	V
I_{LIMIT}	Current Limit		1	1.7	--	A
I_{short}	Short Circuit Current	$V_{IN} = V_{out} + 1V; V_{out} < 0.4V$	--	0.32	--	A
PSRR	Ripple Rejection	$f = 100Hz, V_{IN} = 4.5V$ $V_{p-p} = 1V, I_{Load} = 50mA$		53.6		dB

Note 1: Exceeding the absolute maximum rating may damage the device.

Note 2: The device is not guaranteed to function outside its operating rating.

Note 3: The maximum allowable power dissipation at any T_A (ambient temperature) is calculated using: $P_{D(MAX)} = (T_{J(MAX)} - T_A) / \theta_{JA}$. Exceeding the maximum allowable power dissipation will result in excessive die temperature, and the regulator will go into thermal shutdown. See "Thermal Consideration" section for details

Note 4: Output voltage temperature coefficient is the worst case voltage change divided by the total temperature range.

Note 5: Regulation is measured at constant junction temperature using low duty cycle pulse testing. Parts are tested for load regulation in the load range from 10mA to 600mA. Changes in output voltage due to heating effects are covered by the thermal regulation specification.

Note 6: Dropout voltage is defined as the input to output differential at which the output voltage drops 2% below its nominal value measured at 1V differential. Input voltage above minimum $V_{in} = 2V$.



Typical Performance Characteristics

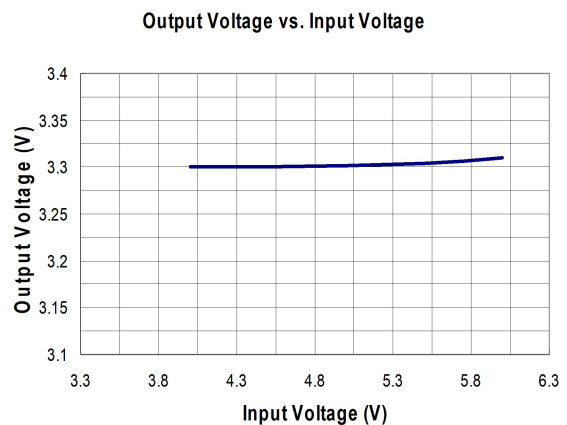
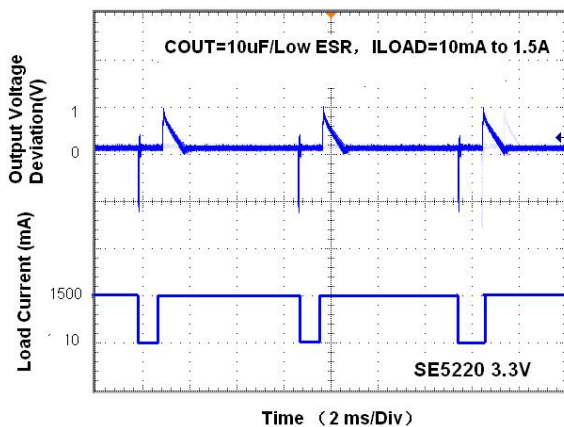
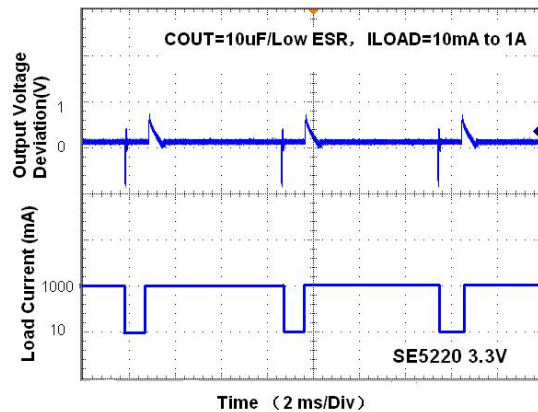
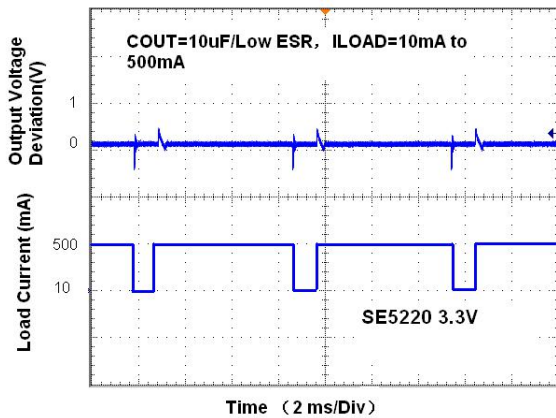
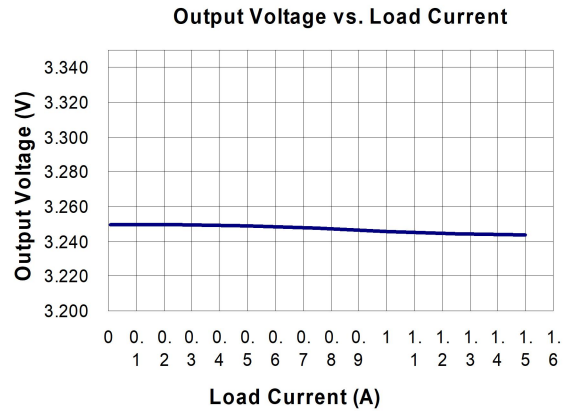
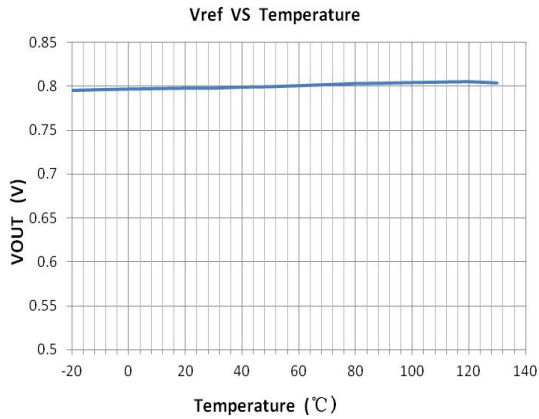

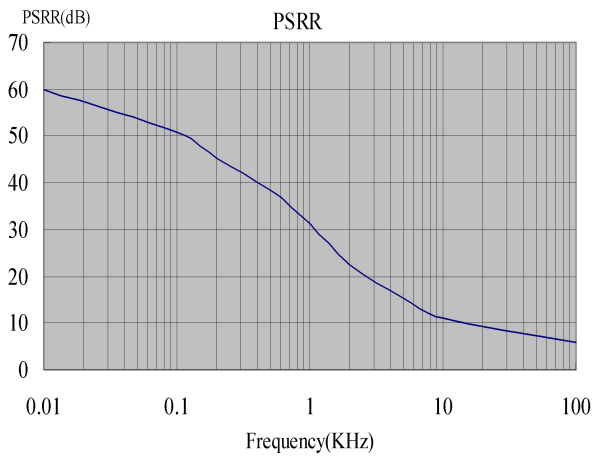



Applications Information

Application Hints

Like any low dropout regulator, SE5220 requires external capacitors to ensure stability. The external capacitors must be carefully selected to ensure performance.

Input Capacitor

An input capacitor of at least 10 μ F is required. Ceramic or Tantalum can be used. The value can be increased without upper limit.

Output Capacitor

An output capacitor is required for stability. It must be placed no more than 1 cm away from the V_{OUT} pin, and connected directly between V_{OUT} and GND pins. The minimum value is 10 μ F but may be increased without limit.

Thermal Considerations

It is important that the thermal limit of the package is not exceeded. The SE5220 has built-in thermal protection. When the thermal limit is exceeded, the IC will enter protection, and V_{OUT} will be pulled to ground. The power dissipation for a given application can be calculated as following:

The power dissipation (P_D) is

$$P_D = I_{OUT} * [V_{IN} - V_{OUT}]$$

The thermal limit of the package is then limited to $P_{D(MAX)} = [T_J - T_A] / \Theta_{JA}$ where T_J is the junction temperature, T_A is the ambient temperature, and Θ_{JA} is around 150°C/W (SOT23-5) for SE5220. SE5220 is designed to enter thermal protection at 150°C. For example, if T_A is 25°C then the maximum P_D is limited to about 0.7W. In other words, if I_{OUT(MAX)} = 300mA, then [V_{IN} - V_{OUT}] cannot exceed 2.33V. (Test condition for all packages: Device mounted on FR-4 substrate PC board, 1oz copper, with minimum recommended pad layout.)



Outline Drawing For SOT23-5

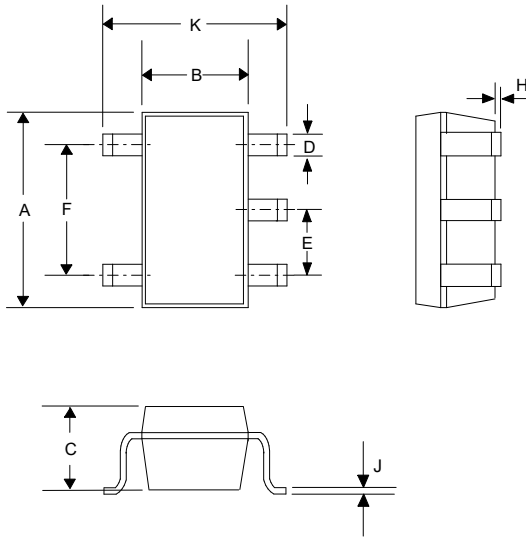

DIMENSIONS				
DIM ^N	INCHES		MM	
	MIN	MAX	MIN	MAX
A	0.110	0.120	2.80	3.05
B	0.059	0.070	1.50	1.75
C	0.036	0.051	0.90	1.30
D	0.014	0.020	0.35	0.50
E	-	0.037	-	0.95
F	-	0.075	-	1.90
H	-	0.006	-	0.15
J	0.0035	0.008	0.090	0.20
K	0.102	0.118	2.60	3.00

Outline Drawing For PSOP8

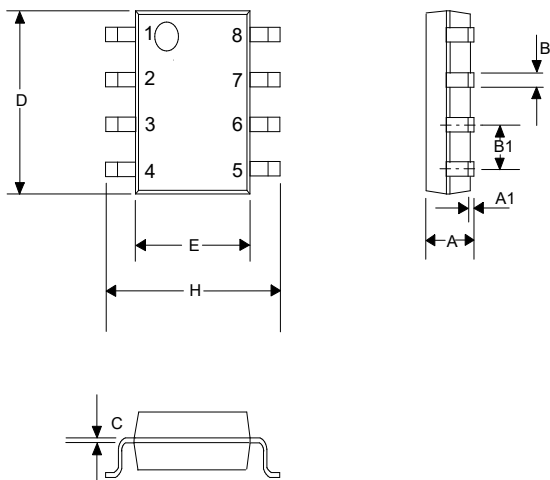

DIMENSIONS				
DIM ^N	INCHES		MM	
	MIN	MAX	MIN	MAX
A	0.0532	0.0688	1.35	1.75
A1	0.0040	0.0098	0.10	0.25
B	0.0130	0.0200	0.33	0.51
B1	0.050 BSC		1.27 BSC	
C	0.0075	0.0098	0.19	0.25
D	0.1890	0.1968	4.80	5.00
H	0.2284	0.2440	5.80	6.20
E	0.1497	0.1574	3.80	4.00



联系方式:

北京思旺电子有限公司-中国总部

地址: 中国北京市海淀区信息路 22 号上地科技综合楼 B 座二层

邮编: 100085

电话:010-82895700/1/5

传真:010-82895706

Seaward Electronics Corporation – 台湾办事处

2F, #181, Sec. 3, Minguan East Rd,

Taipei, Taiwan R.O.C

电话: 886-2-2712-0307

传真: 886-2-2712-0191

Seaward Electronics Incorporated – 北美办事处

1512 Centre Pointe Dr.

Milpitas, CA95035, USA

电话: 1-408-821-6600

X-ON Electronics

Largest Supplier of Electrical and Electronic Components

Click to view similar products for [LDO Voltage Regulators](#) category:

Click to view products by [Seaward](#) manufacturer:

Other Similar products are found below :

[M38D29FFHP#U1](#) [702103A](#) [717726C](#) [742457H](#) [MP20051DN-LF-Z](#) [R5F111PGGFB#30](#) [AP7363-SP-13](#) [NCP103AMX285TCG](#)
[NCV8664CST33T3G](#) [NCV8752AMX28TCG](#) [L9454](#) [AP7362-HA-7](#) [LX13043CLD](#) [TCR3DF185,LM\(CT](#) [TCR3DF24,LM\(CT](#)
[TCR3DF285,LM\(CT](#) [TCR3DF31,LM\(CT](#) [TCR3DF45,LM\(CT](#) [TLF4949EJ](#) [L9708](#) [L970813TR](#) [030014BB](#) [059985X](#) [EAN61387601](#)
[EAN61573601](#) [NCP121AMX173TCG](#) [NCP4687DH15T1G](#) [NCV8703MX30TCG](#) [701326R](#) [702087BB](#) [755078E](#) [TCR2EN28,LF\(S](#)
[LM1117DT-1.8/NO](#) [LT1086CM#TRPBF](#) [AZ1085S2-1.5TRE1](#) [MAX15101EWL+T](#) [NCV8170AXV250T2G](#) [SCD337BTG](#)
[TCR3DF27,LM\(CT](#) [TCR3DF19,LM\(CT](#) [TCR3DF125,LM\(CT](#) [TCR2EN18,LF\(S](#) [MAX15103EWL+T](#) [TS2937CZ-5.0 C0](#) [MAX8878EUK30-](#)
[T](#) [MAX663CPA](#) [NCV4269CPD50R2G](#) [NCV8716MT30TBG](#) [AZ1117IH-1.2TRG1](#) [MP2013GQ-P](#)