



SGM3717

4Ω, 400MHz Bandwidth, Dual, SPDT Negative Signal Handling Analog Switch

GENERAL DESCRIPTION

The SGM3717 is a dual, bidirectional, single-pole/double-throw (SPDT) CMOS analog switch designed to operate from a single +2.5V to +5.0V supply. It features high bandwidth (400MHz) and low on-resistance (4Ω TYP), and the switches can handle negative signal down to -2.0V.

SGM3717 features a guaranteed on-resistance matching of 0.15Ω (TYP) between switches and a guaranteed on-resistance flatness of 1.5Ω (TYP) over the signal range. This ensures excellent linearity and low distortion when switching audio signals.

The SGM3717 is a committed dual single-pole/double-throw (SPDT) switch that consists of two normally open (NO) and two normally closed (NC) switches. This configuration can be used as a dual 2-to-1 multiplexer.

SGM3717 is available in UTQFN-1.8×1.4-10L package.

FEATURES

- **Supply Range: +2.5V to +5.0V**
- **Negative Signal Swing Capability: -2.0V to V₊**
- **On-Resistance: 4Ω (TYP) at +5.0V**
- **High Bandwidth: 400MHz**
- **Fast Switching Times**
 - $t_{ON} = 15\text{ns (TYP)}$
 - $t_{OFF} = 11\text{ns (TYP)}$
- **High Off-Isolation: -49dB at 10MHz**
- **Low Crosstalk: -52dB at 10MHz**
- **1.8V Logic Control**
- **Break-Before-Make Switching**
- **Extended Industrial Temperature Range: -40°C to +85°C**
- **Small Package**
 - Available in Green UTQFN-1.8×1.4-10L Package**

APPLICATIONS

Portable Instrumentation
Battery-Operated Equipment
Computer Peripherals
Cell Phones
PDAs
MP3s

SGM3717

4Ω, 400MHz Bandwidth, Dual, SPDT Negative Signal Handling Analog Switch

PACKAGE/ORDERING INFORMATION

MODEL	ORDERING NUMBER	PIN-PACKAGE	SPECIFIED TEMPERATURE RANGE	PACKAGE MARKING	PACKAGE OPTION
SGM3717	SGM3717YUWQ10G/TR	UTQFN-1.8×1.4-10L	-40°C to +85°C	A3XX	Tape and Reel, 3000

NOTE: Package marking is defined as the follow:

MARKING INFORMATION

A3 X X

Date code - Month ("A" = Jan, "B" = Feb. ... "L" = Dec.)

Date code - Year ("A" = 2010, "B" = 2011 ...)

Chip I.D.

For example: A3BA (2011, January)

ABSOLUTE MAXIMUM RATINGS

V ₊ , IN to GND.....	-0.3V to +6V
Analog, Digital Voltage Range ⁽²⁾ (V ₊) - 6.0V to (V ₊) + 0.3V	
Continuous Current NO, NC, or COM.....	±50mA
Peak Current NO, NC, or COM.....	±80mA
Operating Temperature Range.....	-40°C to +85°C
Junction Temperature.....	150°C
Storage Temperature Range.....	-65°C to +150°C
Lead Temperature (Soldering, 10s).....	260°C
ESD Susceptibility	
HBM.....	6000V
MM.....	400V

NOTES:

1. Stresses beyond those listed under "Absolute Maximum Ratings" may cause permanent damage to the device. These are stress ratings only, and functional operation of the device at these or any other conditions beyond those indicated in the operational sections of the specifications is not implied. Exposure to absolute maximum rating conditions for extended periods may affect device reliability.

2. Signals on NC, NO, or COM or IN exceeding V₊ will be clamped by internal diodes. Limit forward diode current to maximum current ratings.

CAUTION

This integrated circuit can be damaged by ESD if you don't pay attention to ESD protection. SGMICRO recommends that all integrated circuits be handled with appropriate precautions. Failure to observe proper handling and installation procedures can cause damage. ESD damage can range from subtle performance degradation to complete device failure. Precision integrated circuits may be more susceptible to damage because very small parametric changes could cause the device not to meet its published specifications.

SGMICRO reserves the right to make any change in circuit design, specification or other related things if necessary without notice at any time. Please contact SGMICRO sales office to get the latest datasheet.

PIN CONFIGURATION (TOP VIEW)

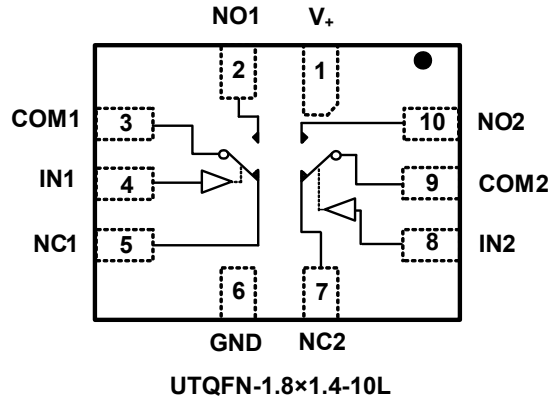

FUNCTION TABLE

LOGIC	NO	NC
0	OFF	ON
1	ON	OFF

NOTE: Switches shown for logic “0” input.

PIN DESCRIPTION

NAME	PIN	FUNCTION
V ₊	1	Power Supply.
GND	6	Ground.
IN1, IN2	4, 8	Digital Control Pin to Connect the COM Terminal to the NO or NC Terminals.
COM1, COM2	3, 9	Common Terminal.
NO1, NO2	2, 10	Normally-Open Terminal.
NC1, NC2	5, 7	Normally-Closed Terminal.

NOTE: NO_x, NC_x and COM_x terminals may be an input or output.

SGM3717

4Ω, 400MHz Bandwidth, Dual, SPDT Negative Signal Handling Analog Switch

ELECTRICAL CHARACTERISTICS

(V₊ = +4.5V to +5.0V, Full = -40°C to +85°C, typical values are at V₊ = +5.0V, T_A = +25°C, unless otherwise noted.)

PARAMETER	SYMBOL	CONDITIONS	TEMP	MIN	TYP	MAX	UNITS
ANALOG SWITCH							
Analog Signal Range	V _{NO} , V _{NC} , V _{COM}	2.5V ≤ V ₊ ≤ 3.5V	Full	-2.0		V ₊	V
		3.5V ≤ V ₊ ≤ 5.0V		(V ₊) - 5.5		V ₊	
On-Resistance	R _{ON}	V ₊ = 4.5V, V _{NO} or V _{NC} = 3.5V, I _{COM} = -10mA, Test Circuit 1	+25°C		4	8	Ω
			Full			8.5	
On-Resistance Match Between Channels	ΔR _{ON}	V ₊ = 4.5V, V _{NO} or V _{NC} = 3.5V, I _{COM} = -10mA, Test Circuit 1	+25°C		0.15	0.6	Ω
			Full			0.8	
On-Resistance Flatness	R _{FLAT(ON)}	V ₊ = 4.5V, 0V ≤ V _{NO} or V _{NC} ≤ V ₊ , I _{COM} = -10mA, Test Circuit 1	+25°C		1.5	3	Ω
			Full			3.5	
Source OFF Leakage Current	I _{NC(OFF)} , I _{NO(OFF)}	V ₊ = 5.0V, V _{NO} or V _{NC} = 1.0V/4.5V, V _{COM} = 4.5V/1.0V	Full			1	μA
Channel ON Leakage Current	I _{NC(ON)} , I _{NO(ON)} , I _{COM(ON)}	V ₊ = 5.0V, V _{COM} = 1.0V/4.5V, V _{NO} or V _{NC} = 1.0V/4.5V or floating	Full			1.2	μA
Power Off Leakage Current	I _{Power Off}	V ₊ = 0V, V _{NO} or V _{NC} = 0V, V _{COM} = 5.0V	Full			10	μA
DIGITAL INPUTS							
Input High Voltage	V _{INH}		Full	1.5			V
Input Low Voltage	V _{INL}		Full			0.6	V
Input Leakage Current	I _{IN}	V ₊ = 5.0V, V _{IN} = 0V or 5.0V	Full			1.5	μA
DYNAMIC CHARACTERISTICS							
Turn-On Time	t _{ON}	V _{NO} or V _{NC} = 3.0V, R _L = 300Ω, C _L = 35pF, Test Circuit 2	+25°C		15		ns
Turn-Off Time	t _{OFF}	V _{NO} or V _{NC} = 3.0V, R _L = 300Ω, C _L = 35pF, Test Circuit 2	+25°C		11		ns
Break-Before-Make Time Delay	t _D	V _{NO1} or V _{NC1} = V _{NO2} or V _{NC2} = 3.0V, R _L = 300Ω, C _L = 35pF, Test Circuit 3	+25°C		6		ns
Skew	t _{SKREW}	R _S = 39Ω, C _L = 50pF, Test Circuit 4	+25°C		1		ns
Off Isolation	O _{ISO}	Signal = 0dBm, R _L = 50Ω, C _L = 5pF, Test Circuit 5	f = 1MHz	+25°C		-70	dB
			f = 10MHz	+25°C		-49	dB
Channel-to-Channel Crosstalk	X _{TALK}	Signal = 0dBm, R _L = 50Ω, C _L = 5pF, Test Circuit 6	f = 1MHz	+25°C		-72	dB
			f = 10MHz	+25°C		-52	dB
-3dB Bandwidth	BW	Signal = 0dBm, R _L = 50Ω, C _L = 5pF, Test Circuit 7	+25°C		400		MHz
Charge Injection	Q	V _G = GND, R _G = 0Ω, C _L = 1.0nF, Test Circuit 8	+25°C		16		pC
Switch ON Capacitance	C _{ON}		+25°C		24		pF
Switch OFF Capacitance	C _{OFF}		+25°C		9		pF
POWER REQUIREMENTS							
Power Supply Current	I ₊	V ₊ = 5.0V, V _{IN} = 0V or V ₊	Full		0.5	6.0	μA

SGM3717

4Ω, 400MHz Bandwidth, Dual, SPDT Negative Signal Handling Analog Switch

ELECTRICAL CHARACTERISTICS

(V₊ = +2.7V to +3.6V, Full = -40°C to +85°C, typical values are at V₊ = +3.0V, T_A = +25°C, unless otherwise noted.)

PARAMETER	SYMBOL	CONDITIONS	TEMP	MIN	TYP	MAX	UNITS
ANALOG SWITCH							
Analog Signal Range	V _{NO} , V _{NC} , V _{COM}	2.5V ≤ V ₊ ≤ 3.5V	Full	-2.0		V ₊	V
		3.5V ≤ V ₊ ≤ 5.0V		(V ₊) - 5.5		V ₊	
On-Resistance	R _{ON}	V ₊ = 2.7V, V _{NO} or V _{NC} = 1.5V, I _{COM} = -10mA, Test Circuit 1	+25°C		6	10	Ω
			Full			10.5	
On-Resistance Match Between Channels	ΔR _{ON}	V ₊ = 2.7V, V _{NO} or V _{NC} = 1.5V, I _{COM} = -10mA, Test Circuit 1	+25°C		0.25	0.85	Ω
			Full			1.0	
On-Resistance Flatness	R _{FLAT(ON)}	V ₊ = 2.7V, 0V ≤ V _{NO} or V _{NC} ≤ V ₊ , I _{COM} = -10mA, Test Circuit 1	+25°C		3	5.1	Ω
			Full			5.4	
Source OFF Leakage Current	I _{NC(OFF)} , I _{NO(OFF)}	V ₊ = 3.6V, V _{NO} or V _{NC} = 0.3V/3.3V, V _{COM} = 3.3V/0.3V	Full			1	μA
Channel ON Leakage Current	I _{NC(ON)} , I _{NO(ON)} , I _{COM(ON)}	V ₊ = 3.6V, V _{COM} = 0.3V/3.3V, V _{NO} or V _{NC} = 0.3V/3.3V or floating	Full			1	μA
Power Off Leakage Current	I _{Power Off}	V ₊ = 0V, V _{NO} or V _{NC} = 0V, V _{COM} = 3.0V	Full			10	μA
DIGITAL INPUTS							
Input High Voltage	V _{INH}		Full	1.3			V
Input Low Voltage	V _{INL}		Full			0.5	V
Input Leakage Current	I _{IN}	V ₊ = 3.6V, V _{IN} = 0V or 3.6V	Full			1	μA
DYNAMIC CHARACTERISTICS							
Turn-On Time	t _{ON}	V _{NO} or V _{NC} = 1.5V, R _L = 300Ω, C _L = 35pF, Test Circuit 2	+25°C		24		ns
Turn-Off Time	t _{OFF}	V _{NO} or V _{NC} = 1.5V, R _L = 300Ω, C _L = 35pF, Test Circuit 2	+25°C		15		ns
Break-Before-Make Time Delay	t _D	V _{NO1} or V _{NC1} = V _{NO2} or V _{NC2} = 1.5V, R _L = 300Ω, C _L = 35pF, Test Circuit 3	+25°C		10		ns
Skew	t _{SKEW}	R _S = 39Ω, C _L = 50pF, Test Circuit 4	+25°C		1		ns
Off Isolation	O _{ISO}	Signal = 0dBm, R _L = 50Ω, C _L = 5pF, Test Circuit 5	f = 1MHz	+25°C		-70	dB
			f = 10MHz	+25°C		-49	dB
Channel-to-Channel Crosstalk	X _{TALK}	Signal = 0dBm, R _L = 50Ω, C _L = 5pF, Test Circuit 6	f = 1MHz	+25°C		-72	dB
			f = 10MHz	+25°C		-52	dB
-3dB Bandwidth	BW	Signal = 0dBm, R _L = 50Ω, C _L = 5pF, Test Circuit 7	+25°C		400		MHz
Charge Injection	Q	V _G = GND, R _G = 0Ω, C _L = 1.0nF, Test Circuit 8	+25°C		10		pC
Switch ON Capacitance	C _{ON}		+25°C		24		pF
Switch OFF Capacitance	C _{OFF}		+25°C		9		pF
Total Harmonic Distortion	THD	V ₊ = 3.3V, V _{NC/NO} = 2.0V _{PP} , R _L = 600Ω f = 20Hz to 20kHz, Test Circuit 9	+25°C		0.025		%
		V ₊ = 3.3V, V _{NC/NO} = 1.0V _{PP} , R _L = 32Ω f = 20Hz to 20kHz, Test Circuit 9	+25°C		0.35		
POWER REQUIREMENTS							
Power Supply Current	I ₊	V ₊ = 3.6V, V _{IN} = 0V or V ₊	Full		0.5	6.0	μA

TYPICAL PERFORMANCE CHARACTERISTICS

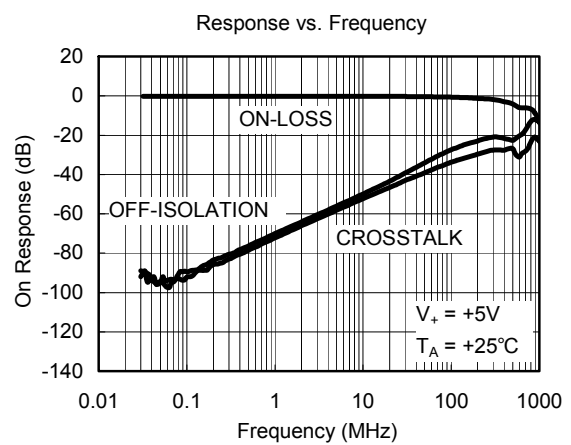
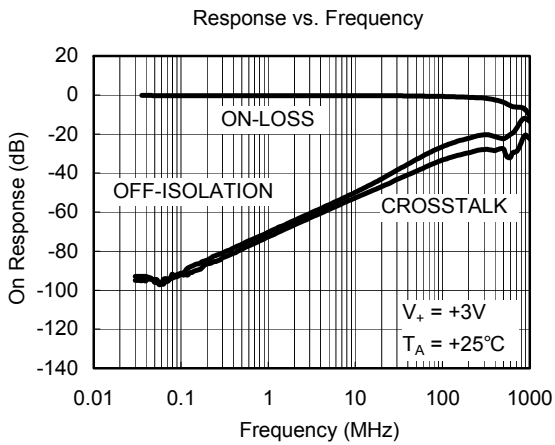
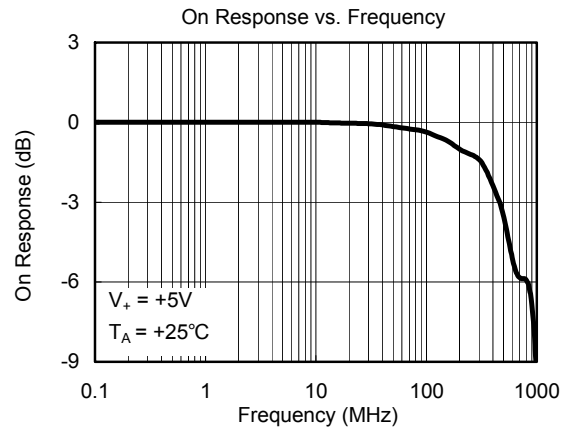
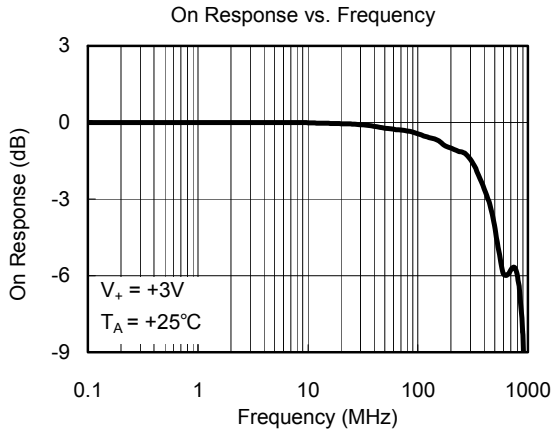

TEST CIRCUITS

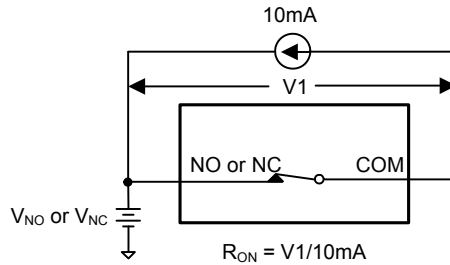

Test Circuit 1. On Resistance

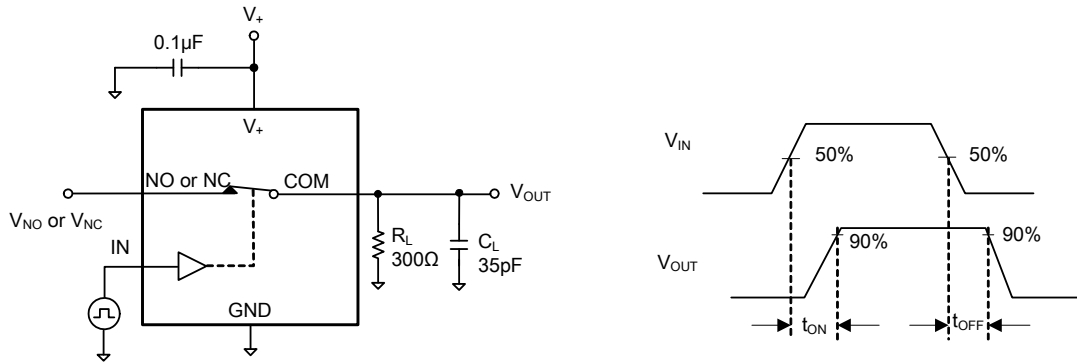

Test Circuit 2. Switching Times

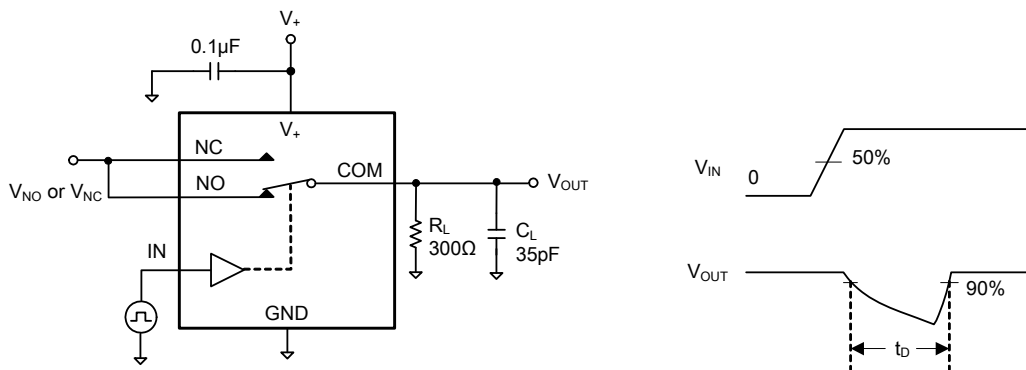

Test Circuit 3. Break-Before-Make Time Delay (t_b)

TEST CIRCUITS (Cont.)

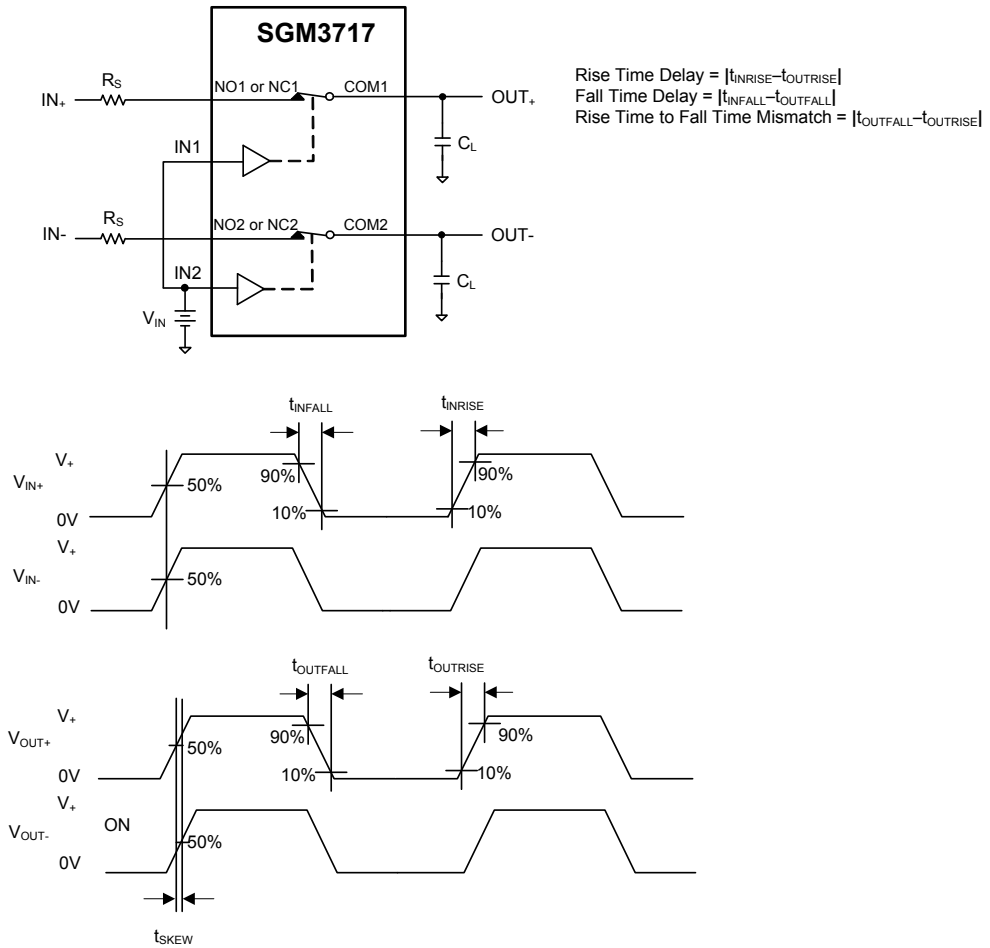

Test Circuit 4. Output Signal Skew (T_{SKEW})

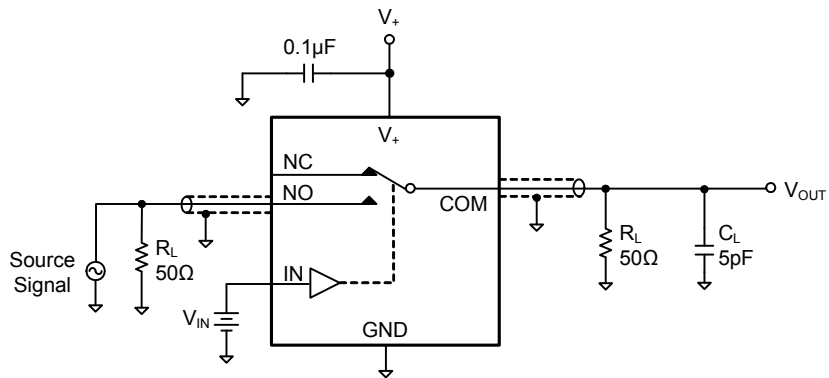

Test Circuit 5. Off Isolation (O_{ISO})

TEST CIRCUITS (Cont.)

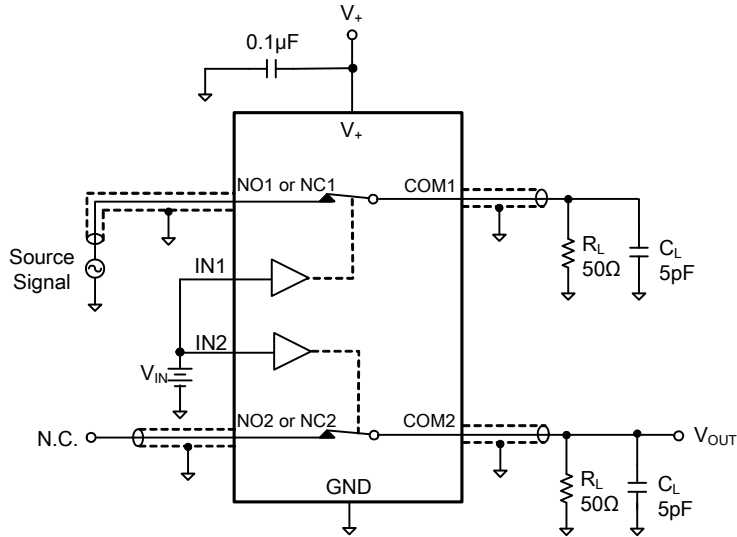

$$\text{Channel to Channel Crosstalk} = 20 \times \log \frac{V_{OUT}}{V_{NO \text{ or } V_{NC}}}$$

Test Circuit 6. Channel-to-Channel Crosstalk (X_{TALK})

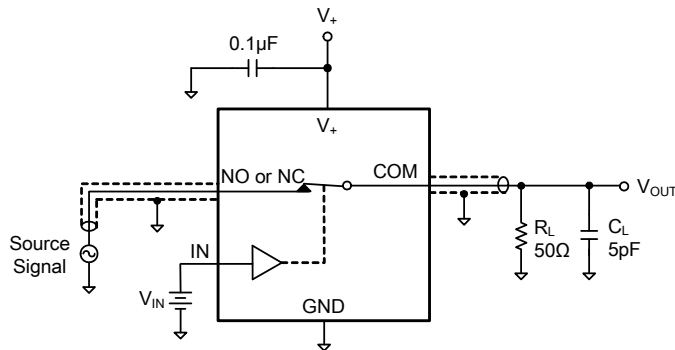

Test Circuit 7. -3dB Bandwidth (BW)

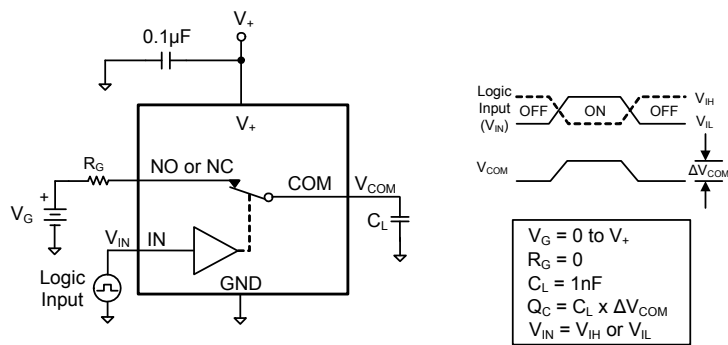

Test Circuit 8. Charge Injection (Q)

TEST CIRCUITS (Cont.)

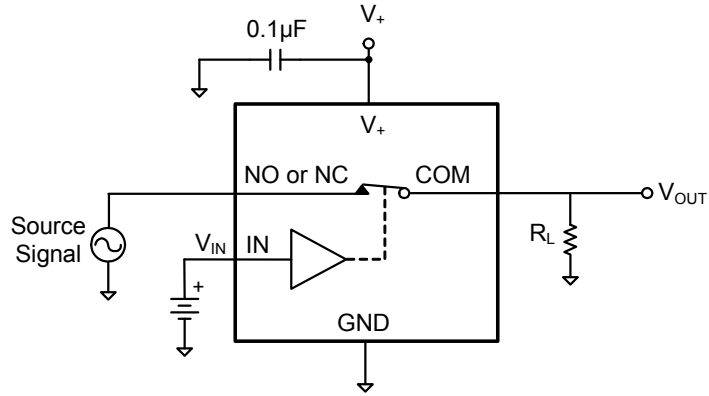

Test Circuit 9. Total Harmonic Distortion (THD)

APPLICATION

In order to enhance the negative signal swing capability of SGM3717, the circuit in Figure 1 is recommended. R1 and R2 will prevent the device from entering into latch-up state when passing negative signal.

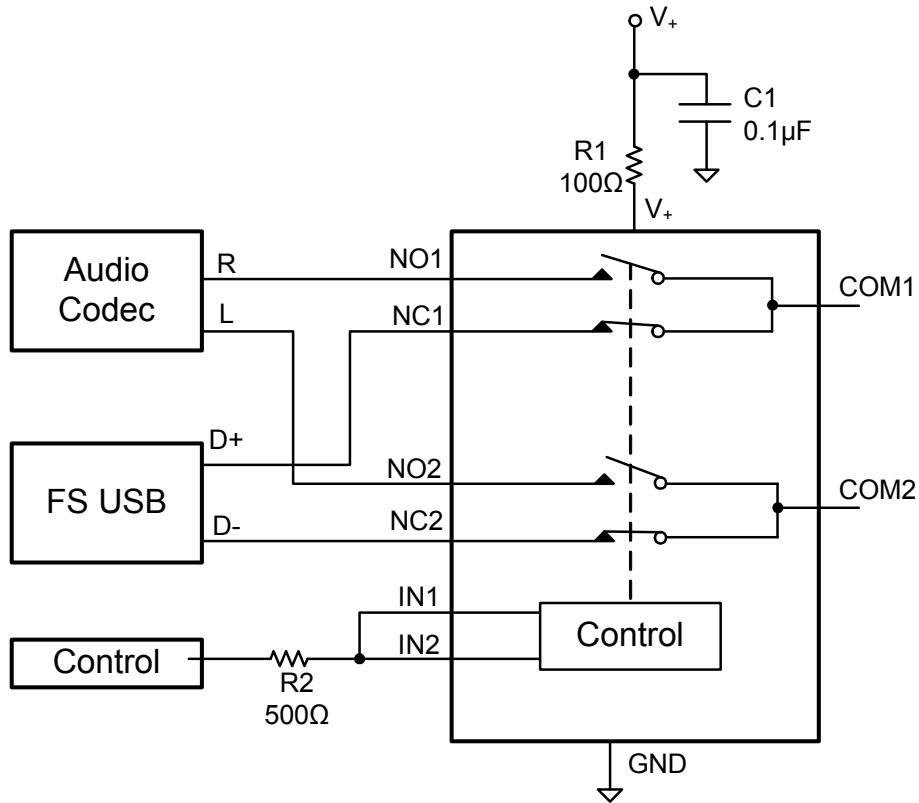

Figure 1. Typical Application Circuit

SGM3717

4Ω, 400MHz Bandwidth, Dual, SPDT
Negative Signal Handling Analog Switch

PACKAGE OUTLINE DIMENSIONS

UTQFN-1.8×1.4-10L

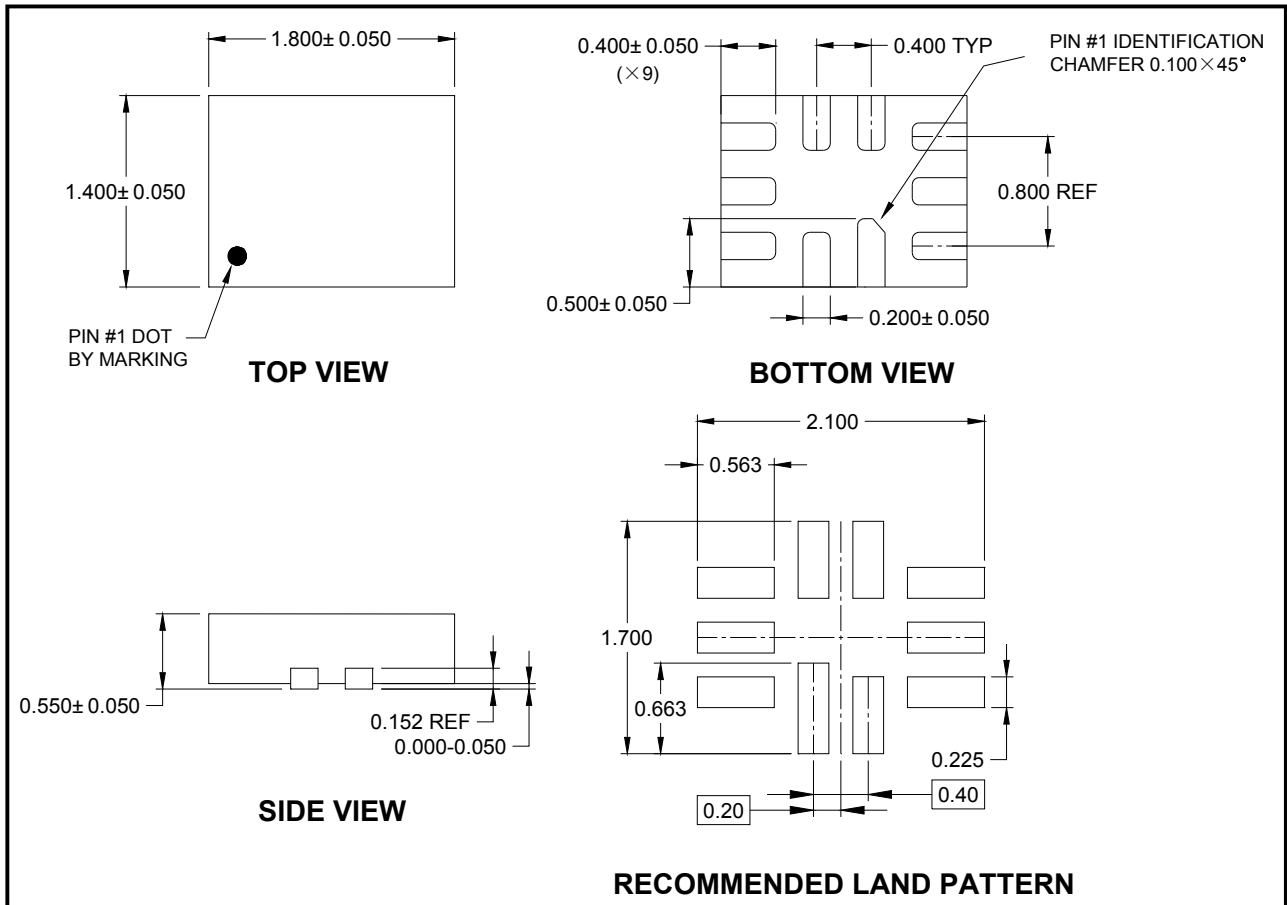

NOTE: All linear dimensions are in millimeters.

TAPE AND REEL INFORMATION

REEL DIMENSIONS

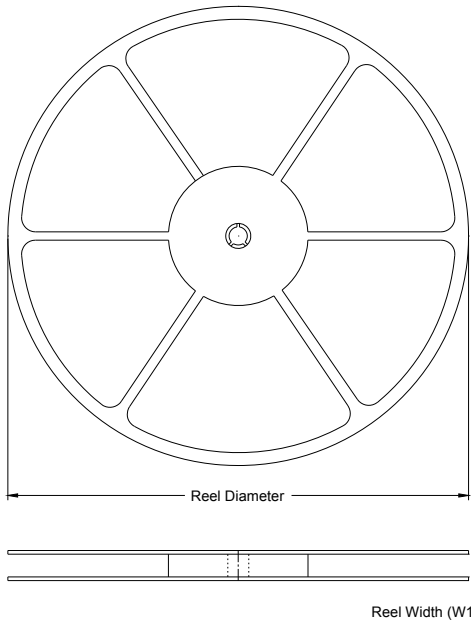

TAPE DIMENSIONS

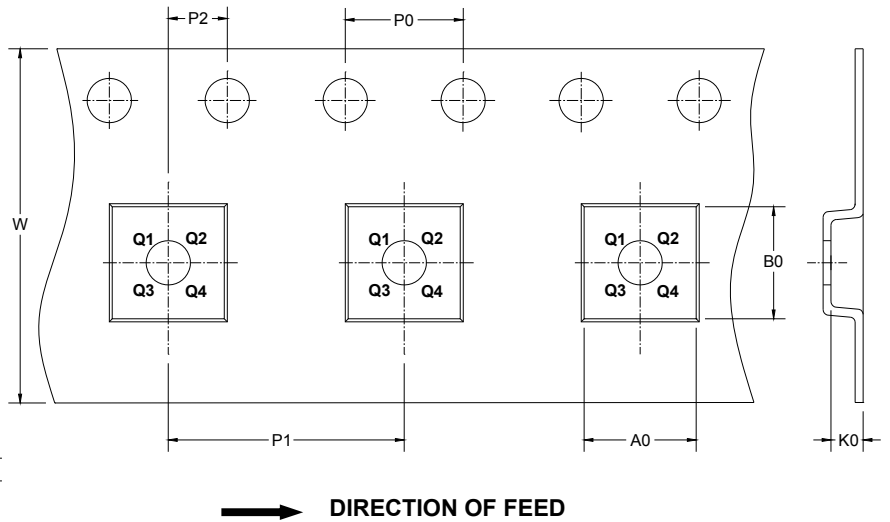

NOTE: The picture is only for reference. Please make the object as the standard.

KEY PARAMETER LIST OF TAPE AND REEL

Package Type	Reel Diameter	Reel Width W1 (mm)	A0 (mm)	B0 (mm)	K0 (mm)	P0 (mm)	P1 (mm)	P2 (mm)	W (mm)	Pin1 Quadrant
UTQFN-1.8×1.4-10L	7"	9.0	1.75	2.10	0.70	4.00	4.00	2.00	8.00	Q1

SGM3717

4Ω, 400MHz Bandwidth, Dual, SPDT Negative Signal Handling Analog Switch

CARTON BOX DIMENSIONS

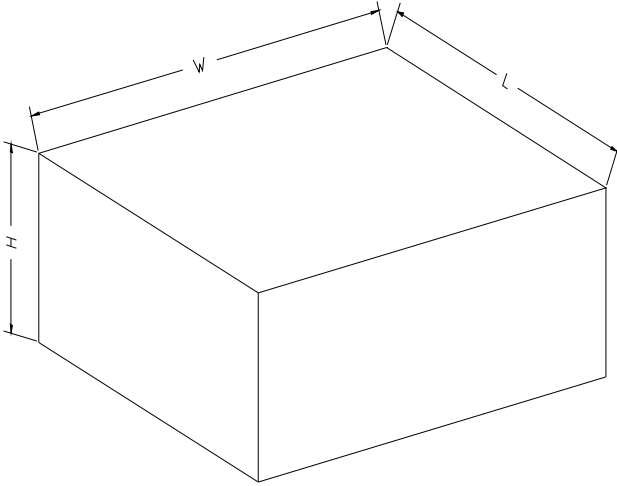

NOTE: The picture is only for reference. Please make the object as the standard.

KEY PARAMETER LIST OF CARTON BOX

Reel Type	Length (mm)	Width (mm)	Height (mm)	Pizza/Carton
7" (Option)	368	227	224	8
7"	442	410	224	18

X-ON Electronics

Largest Supplier of Electrical and Electronic Components

Click to view similar products for [Analogue Switch ICs category](#):

Click to view products by [SGMICRO manufacturer](#):

Other Similar products are found below :

[FSA3051TMX](#) [NLVAS4599DTT1G](#) [MAX4992EVB+T](#) [MAX4684ETB+T](#) [BCM6522IPBG](#) [BCM65300IFSBG](#) [MAX14764ETA+T](#)
[TMUX1113RSVR](#) [TMUX1112RSVR](#) [ADG1436TRUZ-EP](#) [BL4684C](#) [PE423422A](#) [PE42359SCAA](#) [PE42540F](#) [RS550YUCM12](#)
[ADGS1414DBCCZ](#) [ADG658YRUZ-REEL7](#) [RS2117YUTQK10](#) [RS2118YUTQK10](#) [RS2227XUTQK10](#) [SP2526A-1EN-L/TR](#) [FSA4157P6X](#)
[BA7603F-E2](#) [MAX4702EUE+](#) [MAX4617CUE+](#) [MAX4599EUT+T](#) [MAX4066ESD+](#) [MAX4052ACSE+](#) [MAX396CAI+](#) [MAX391CPE+](#)
[MAX4730EXT+T](#) [MAX314CPE+](#) [MAX4051AEEE+](#) [BU4066BCFV-E2](#) [MAX313CPE+](#) [BU4S66G2-TR](#) [TS3A4751PWR](#)
[NCN1154MUTAG](#) [DG444DY-E3](#) [NLAS4157DFT2G](#) [NLAS4599DFT2G](#) [NLAS7242MUTBG](#) [NLASB3157DFT2G](#) [NLAST4599DFT2G](#)
[NLAST4599DTT1G](#) [DG403DY-T1-E3](#) [MAX4714EXTT](#) [MAX392CPE](#) [BGSX22G2A10E6327XTSA1](#) [ADG1611BRUZ-REEL7](#)