



HIRSCHMANN

Automation and Network Solutions

# Measuring Highlights



Edition 1

# Precision and reliability in research and technology

For all types of measuring and testing equipment

## **HiTest** measuring and testing accessories

Whether pole clamps, test probes or banana plugs, Hirschmann measuring and testing accessories have long been indispensable aids for the transmission of measurement data, voltages and currents, hence their use in R&D laboratories, test bays and workshops, service facilities, schools, training centres and institutes.

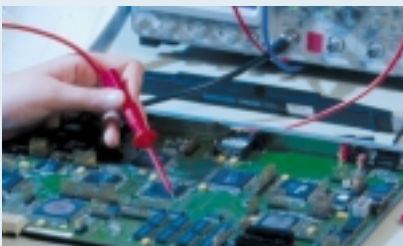

### **A must in research and technology**

Hirschmann **HiTest** measuring and testing products comprise a comprehensive range of shockproof measuring leads and accessories. From miniature connectors for safety extra-low voltage to safety-type products for measuring tasks up to 1.000 V.



The high-quality materials used for the contacts of plug pins and sockets made of tin- or gold-plated brass or copper beryllium, affording outstanding connection, ensure consistent contact quality over prolonged time periods.

For all types of measuring and testing equipment.

To achieve the optimum degree of protection for users of hand-held measuring accessories, the entire product range is provided with double-strength reinforced insulation. Hirschmann attaches considerable importance to ergonomics and design, providing the user with the optimum degree of protection against electric shocks and other hazards.

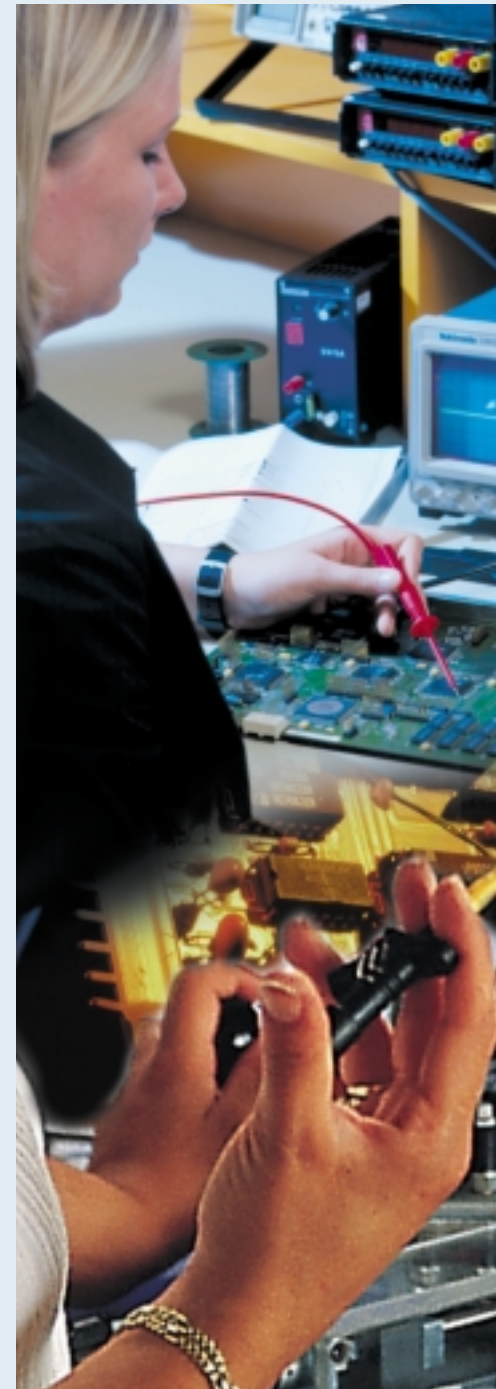

**FULL-SPECTRUM SOLUTIONS  
FROM THE SPECIALIST**

Seeking dialogue, among ourselves and with users. Developing innovative ideas together. Making use of synergies. Establishing productive links. And this via state-of-the-art communication technologies to transmit voice, data and visual information. From modern antenna systems in automobiles, satellite reception and transmission systems to enterprise-wide network solutions. The Hirschmann Group, a subsidiary of

ADITRON AG, employs some 2,700 people around the world who are all committed to achieving this vision.

**AUTOMATION AND  
NETWORK SOLUTIONS  
DIVISION**

With its connectors, fieldbus and fiber optic systems, Hirschmann offers automation solutions in bus, sensor and actuator category. A broad range of connectors for measuring and

testing applications, machine and plant construction as well as building technology are incorporated into the program as well. Industry-specific solutions for company-wide data networks from the workgroup to the backbone, from industrial to office networking, from LAN to WAN complete our range. In all commonly used standards - with a focus on ETHERNET, Fast ETHERNET and Gigabit ETHERNET.

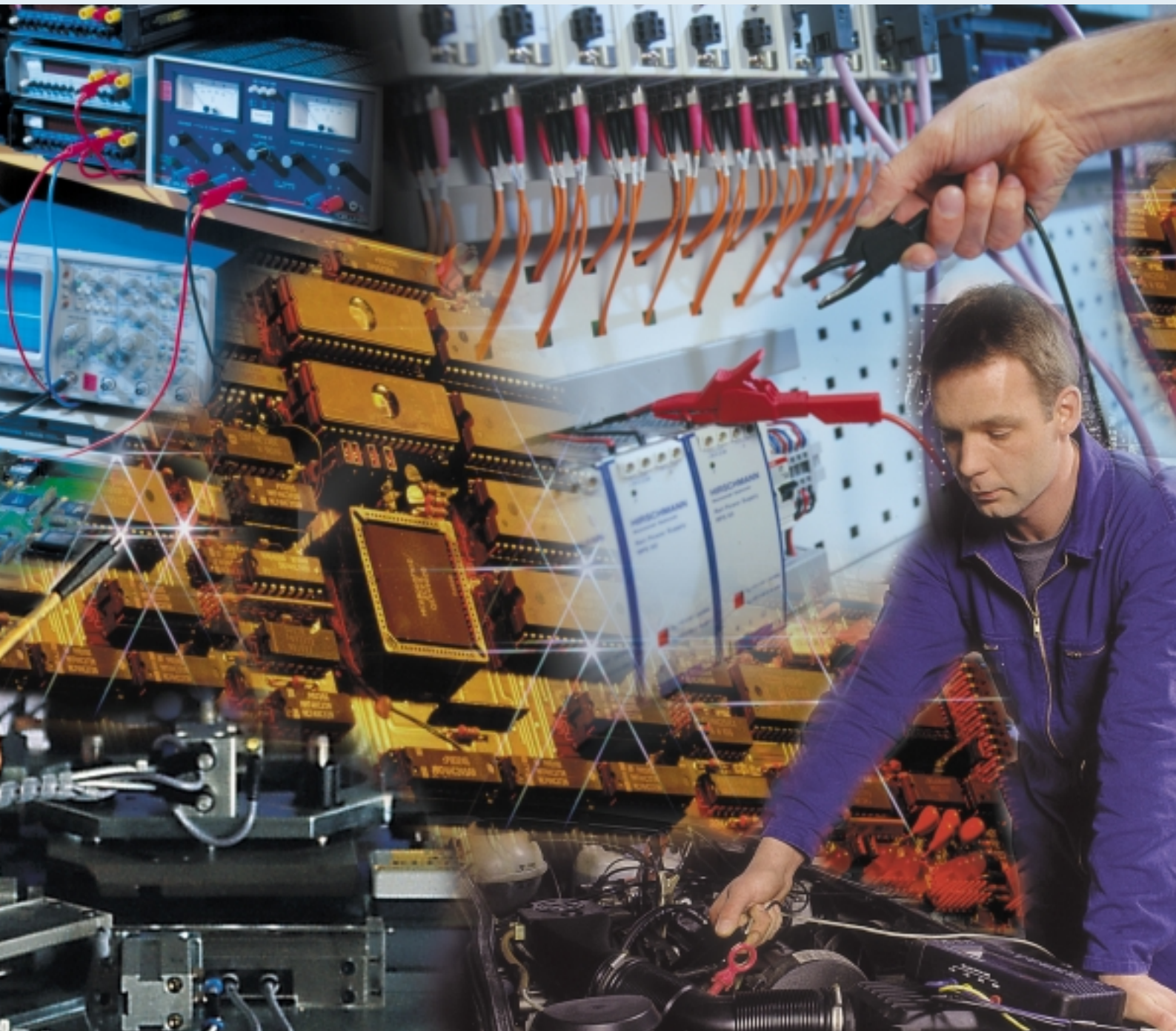

# Table of contents



## Measuring Highlights



Description of systems ..... 6 – 7



Clamp-type test probes ..... 8 – 9



Alligator clips ..... 10 – 11



Test probes ..... 12 – 13



Measuring leads ..... 14 – 19



Plugs ..... 20 – 23



Sockets ..... 24 – 27



IC testers ..... 28



Sets ..... 29 – 30

# HiTest





# Descriptions of systems



The catalogue is subdivided into sections according to applications, e.g. testing with test probes or establishing connections with measuring leads.

All the products are assigned to a system and are fully compatible within that system.

System designations are assigned to the products on the following pages. Unmarked products are unrelated to a system and can be used in combination with any system.

## ⑥ 0.64 mm system

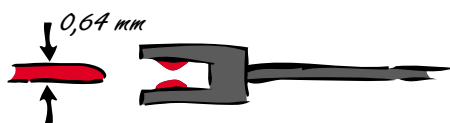

The 0.64 mm system is compatible with standard 0.64 mm printed circuit board plugs. Miniature contacts, fully protected with high-quality contact material ensures efficient connecting and prolonged endurance. With this system, exceptionally small components and measuring points can be tested.

Max. 60 V

## ② 2 mm system

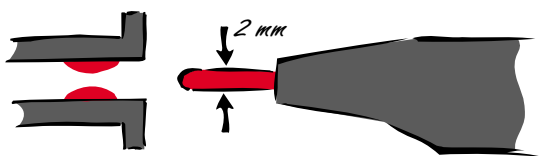

The 2 mm system consists of a solid contact pin and a spring-loaded socket. As a result, the small, high-quality contact pin is protected against mechanical influences.

Max. 60 V

## ④ 4 mm system

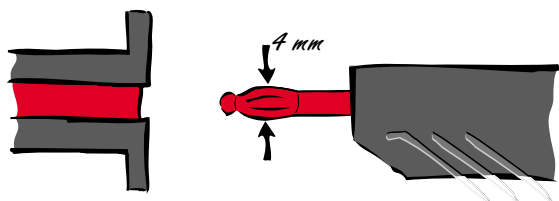

The 4 mm system comprises a spring-loaded contact pin and springless sockets. A variety of compatible contact techniques enable the user to resolve any individual problem. 4 mm plugs can be used in combination with safety sockets, clamp-type test probes, crocodile clips, etc.

Max. 60 V



## ⦿ 4 mm safety system

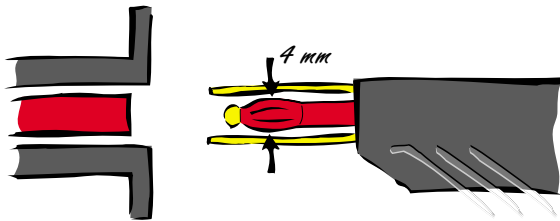

The 4 mm safety system comprises a 4 mm pin with contact spring. The pin is protected against physical contact by a plastic coating and the tip by a plastic cap. The system is completely shockproof and short circuit proof. 4 mm plugs can be plugged into safety sockets (SEB..., KLEPS..., AK...).

The component with the lowest electric strength determines the maximum permissible voltage of the whole system.

The system complies with IEC 1010 (EN 61 010).

Max. 1000 V

## ↔ 4 mm sliding sleeve system

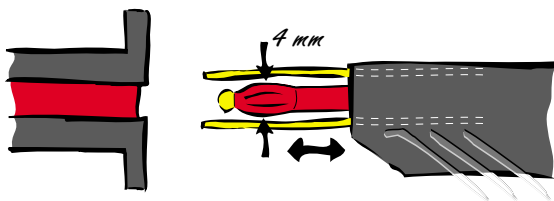

The 4 mm sliding sleeve system is a safety system which provides protection against physical contact by means of a sliding locking spring. The system can be used in combination with any 4 mm system.

Max. 300 V



# Clamp-type test probes

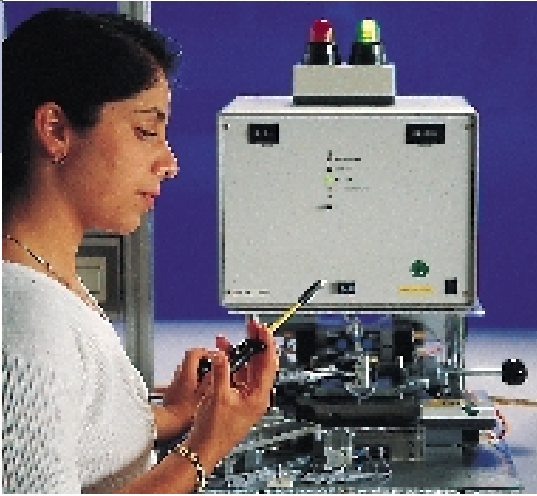

## Product description

Clamp-type test probes provide the simple, rapid measurement of voltages.











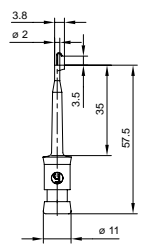

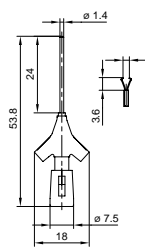

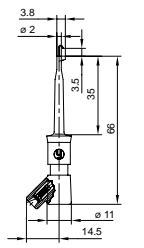
A variety of types and sizes permit the measuring point to be accessed and gripped without difficulty.

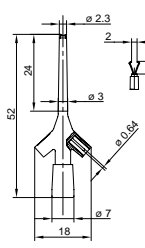
The ergonomic design has been optimised to facilitate handling to the utmost extent.

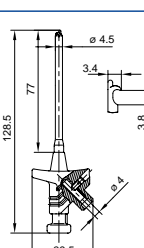
The KLEPS 2700 permits a lead to be tested without the insulation being stripped.

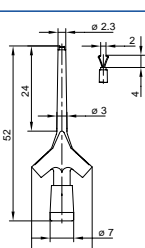
The KLEPS 2800 is provided with claw-type clamps with which large

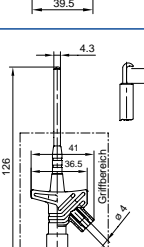
test specimens can be gripped. It is also suitable for testing currents. The classic KLEPS 30, used in millions of applications worldwide, serves as a versatile voltage tap.

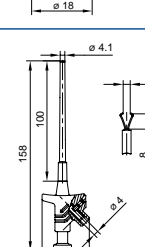







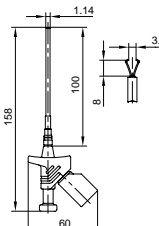

| *System<br>Article type   | Technical<br>Data   | Order no.<br>Colour  | *System<br>Article type   | Technical<br>Data   | Order no.<br>Colour  |
|---|---|--|---|---|--|
| <br>KLEPS 2     |   | Clamping range max. $\varnothing$ 2 mm, contact hook, solder contact<br><b>931 467-100</b> ●<br><b>931 467-101</b> ● | <br>MICRO-KLEPS |   | Very thin wires and densely packed contact points, clamping range $\varnothing$ 2 mm<br><b>973 972-100</b> ●<br><b>973 972-101</b> ●   |
| <br>KLEPS 2-BU |  | Clamping range max. $\varnothing$ 2 mm, contact hook<br><b>973 501-100</b> ●<br><b>973 501-101</b> ●                 | <br>KLEPS 3 ST |  | Very thin wires and densely packed contact points, clamping range $\varnothing$ 3.5 mm<br><b>973 592-100</b> ●<br><b>973 592-101</b> ● |
| <br>KLEPS 10   |  | 20 A clamping range max. $\varnothing$ 2 mm<br><b>930 111-100</b> ●<br><b>930 111-101</b> ●                          | <br>KLEPS 4    |  | Very thin wires and densely packed contact points, clamping range $\varnothing$ 3.5 mm<br><b>973 649-100</b> ●<br><b>973 649-101</b> ● |
| <br>KLEPS 2900 |  | 20 A clamping range 5.5 mm<br><b>972 309-100</b> ●<br><b>972 309-101</b> ●   | <br>KLEPS 30   |  | Clamping range $\varnothing$ 4 mm<br><b>930 113-100</b> ●<br><b>930 113-101</b> ●  |

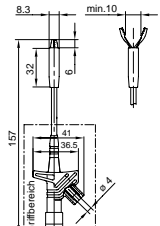
\* System: (64) = 0.64 mm system / (2)  $\hat{=}$  2 mm system / (4)  $\hat{=}$  4 mm system / (●)  $\hat{=}$  4 mm safety system / (↔)  $\hat{=}$  4 mm sliding sleeve system

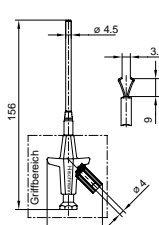

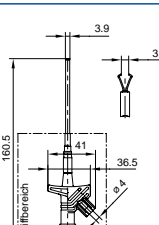
# Clamp-type test probes

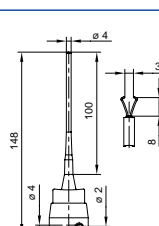

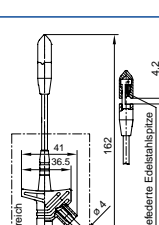
| *System Article type  | Technical Data  | Order no. Colour               | *System Article type  | Technical Data   | Order no. Colour               |
|---|---|--------------------------------|---|--|--------------------------------|
| <br>KLEPS 250    |  <p>300 V = clamping range<br/>                     ø 4 mm</p>   | 973 528-100 ●<br>973 528-101 ● | <br>KLEPS 2800 |  <p>20 A clamping range<br/>                     ø 10 mm, grip claws</p> | 972 308-100 ●<br>972 308-101 ● |
| <br>KLEPS 2000  |  <p>Clamping range<br/>                     ø 4 mm</p>  | 972 378-100 ●<br>972 378-101 ● |   |  |                                |
| <br>KLEPS 2600 |  <p>Clamping range<br/>                     ø 4 mm</p>   | 972 306-100 ●<br>972 306-101 ● |   |  |                                |
| <br>KLEPS 60   |  <p>Clamping range<br/>                     ø 4 mm</p>   | 973 053-100 ●<br>973 053-101 ● |   |  |                                |
| <br>KLEPS 2700 |  <p>0.25 mm<sup>2</sup> up to 1.5 mm<sup>2</sup><br/>                     (ø 3.5 mm) contact without the need to strip them<br/>                     „Piercing Clip“</p> | 972 307-100 ●<br>972 307-101 ● |   |  |                                |

\* System: (64) = 0.64 mm system / (2) = 2 mm system / (4) = 4 mm system / (●) = 4 mm safety system / (↔) = 4 mm sliding sleeve system

# Alligator clips

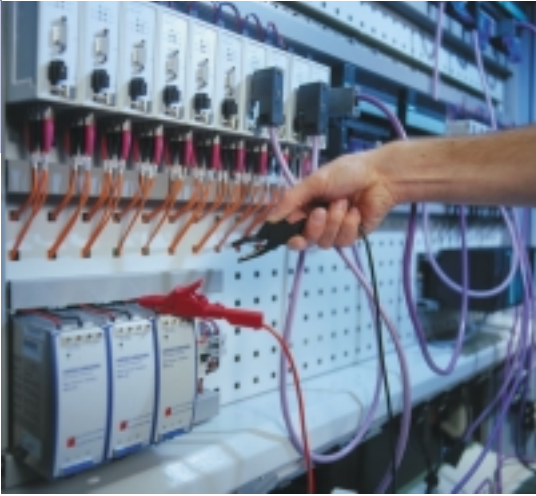

## Product description











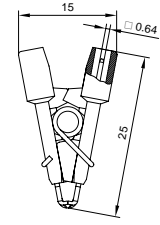

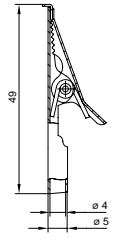

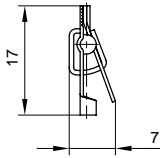
Alligator clips, also known as crocodile clips, are outstandingly suitable for the testing and transfer of currents.

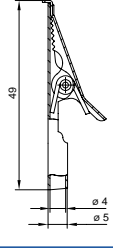
The sharp teeth of the clips bite into the test specimen with little contact resistance.

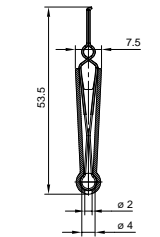
Thanks to their thin wire clamping capability, they are able to make contact with extra finely stranded conductors of minimal cross sections.

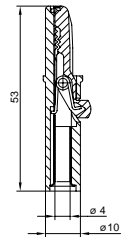
Opening widths up to 30 mm permit large contacts to be securely gripped.

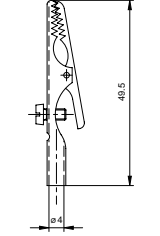

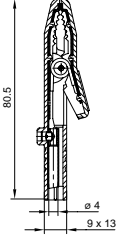



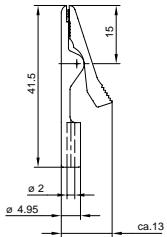

The MICRO-SMD CLIP is used for the two-pole testing of very small SMD components. Crocodile clips are also widely used in non-electrical applications.

| *System Article type   | Technical Data  | Order no. Colour  | *System Article type   | Technical Data  | Order no. Colour   |
|--|---|---|--|---|--|
| (64)<br><br>MICRO-SMD CLIP 1 |   | 2-pole test clip, clamping range 0 up to 8 mm<br><b>972 416-100</b>       | (4)<br><br>AGF 20  |   | <b>930 120-000</b>   |
| <br>AGF 1                   |  | Solder contact<br><b>930 476-001</b>                                      | (4)<br><br>AGF 30 |  | Stainless steel, rust and acid-proof, non-magnetic<br><b>930 122-000</b>   |
| (2) (4)<br><br>AGF 2        |  | Clamping range up to 4 mm<br><b>931 272-100</b> ●<br><b>931 272-101</b> ● | (4)<br><br>AK 10  |  | 6 A clamping range max. 6 mm<br><b>930 126-100</b> ●<br><b>930 126-601</b> ●<br><b>930 126-102</b> ●<br><b>930 126-103</b> ●<br><b>930 126-104</b> ● |
| (4)<br><br>AGS 20           |  | Terminal screw, clamping range max. 5 mm<br><b>603 006-001</b>            | (4)<br><br>AK 2 S |  | 25 A clamping range max. 9.5 mm<br><b>932 146-100</b> ●<br><b>932 146-101</b> ●  |

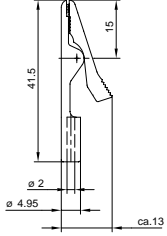
\* System: (64) = 0.64 mm system / (2) ≙ 2 mm system / (4) ≙ 4 mm system / ● ≙ 4 mm safety system / ↔ ≙ 4 mm sliding sleeve system

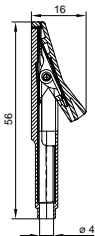
# Alligator clips

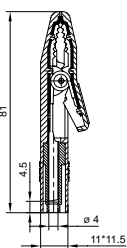

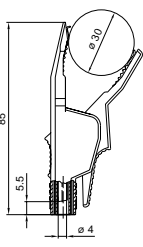
| *System<br>Article type  | Technical<br>Data                              | Order no.<br>Colour            | Notes |
|--|--|--------------------------------|-------|
| (2)<br><br>MA 1<br>              | Clamping range up to 4 mm                      | 930 317-800 ●<br>930 317-801 ● |       |
| (2)<br><br>MA 1 S<br>          | Rust and acid-proof, clamping range up to 4 mm | 973 584-100 ●<br>973 584-101 ● |       |
| (4)<br><br>MA 260 SH<br>     | 15 A 300 V clamping range ø 6 mm               | 973 889-100 ●<br>973 889-101 ● |       |
| (4)<br><br>AK 2 B<br>        | 25 A 300 V clamping range ø 9.5 mm             | 932 435-100 ●<br>932 435-101 ● |       |
| (4)<br><br>AK 2 B 2540 I<br> | 34 A clamping range ø 30 mm                    | 972 405-100 ●<br>972 405-101 ● |       |

\* System: (64) = 0.64 mm system / (2) ≙ 2 mm system / (4) ≙ 4 mm system / (4) ≙ 4 mm safety system / (↔) ≙ 4 mm sliding sleeve system

# Test probes













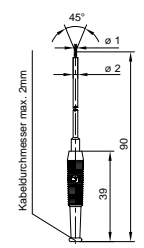

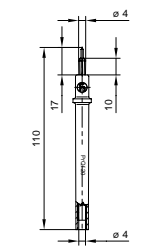

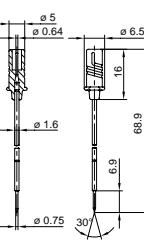
## Product description

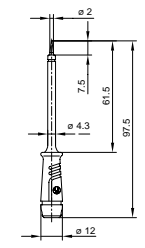
Test probes are used for voltage testing purposes.

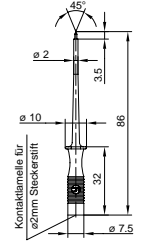
Their needle-like steel tips penetrate oxidation layers, thereby establishing an effective connection with the test specimen.

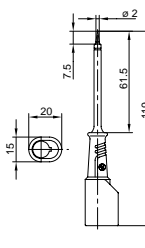

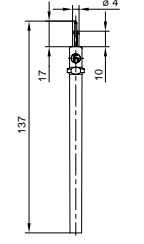

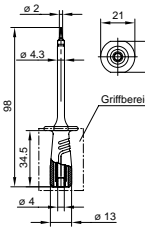
The spring-loaded prods of the MICRO-PRUEF and PRUEF 2610 FT make contact with sensitive components with gently applied spring force. Contact with less vulnerable contact points can be established with the PRUEF 2700, which is

also equipped with a 4 mm pin. The SS 260 prod guard protects the user from injury and ICs from short circuits.

| *System<br>Article type   | Technical<br>Data  | Order no.<br>Colour                                   | *System<br>Article type   | Technical<br>Data   | Order no.<br>Colour            |
|---|--|---|---|---|--------------------------------|
| <br>PRUEF 1                               | <br>Kabeldurchmesser max. 2mm                | Solder contact<br>931 376-100 ●<br>931 376-101 ●      | <br>PRUEF 20          |                   | 973 505-100 ●<br>973 505-101 ● |
| (64)<br><br>MICRO-PRUEF<br>MPS 2/0,64 FT |   | Sprung<br>probe tip<br>973 995-100 ●<br>973 995-101 ● | (4)<br><br>PRUEF 2   |                  | 973 368-100 ●<br>973 368-101 ● |
| (2)<br><br>MPS 1                         | <br>Kontaktstelle für<br>22mm Steckerspitze | 973 531-100 ●<br>973 531-101 ●                        | (4)<br><br>PRUEF 2 S |                  | 973 659-100 ●<br>973 659-100 ● |
| <br>PRUEF 10                             |   | Solder contact<br>930 227-100 ●<br>930 227-101 ●      | <br>PRUEF 2600       | <br>Griffbereich | 972 317-100 ●<br>972 317-101 ● |

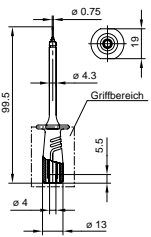
\* System: (64) = 0.64 mm system / (2) ≙ 2 mm system / (4) ≙ 4 mm system / ● ≙ 4 mm safety system / (4) ≙ 4 mm sliding sleeve system

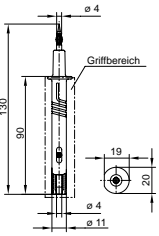

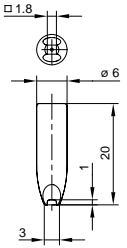
| *System<br>Article type  | Technical<br>Data   | Order no.<br>Colour  | Notes |
|--|---|--|-------|
| <br>PRUEF 2610 FT |    | Sprung<br>stainless<br>steel tip<br><br>972 318-100 ●<br>972 318-101 ● |       |
| <br>PRUEF 2700   |   | 972 319-100 ●<br>972 319-101 ●   |       |
| <br>SS 260      |  | Contact<br>protector,<br>contact<br>help for ICs<br><br>973 865-001    |       |
|  |   |  |       |
|  |   |  |       |

\* System: (64) = 0.64 mm system / (2) ≙ 2 mm system / (4) ≙ 4 mm system / ● ≙ 4 mm safety system / ↔ ≙ 4 mm sliding sleeve system

# Measuring leads



## Product description

Measuring leads connect hardware items such as machines, test equipment, measuring instruments, experimental set-ups, etc. A variety of types permits optimised cable layouts, expansion facilities through stacking and use in differing voltage ranges.

The selection of special-purpose insulating material and cross-sections ensures adaptability and high loading capacities. A special cable configuration incorporates a white tell-tale

mark, indicating possible mechanical damage and a consequential risk to the user. Testing leads, which are typical accessories for multimeters, consist of measuring leads with test probes.

| *System | Article type   | Length "L" in cm | Technical Data                    | Order no. Colour                       |
|---------|----------------|------------------|-----------------------------------|--|
|         | MLS GG 25/1    | 25 cm            | 1 mm <sup>2</sup> , PVC<br>16 A   | <b>934 070-Colour**</b><br>● ● ● ● ●   |
|         | MLS GG 25/2,5  | 25 cm            | 2,5 mm <sup>2</sup> , PVC<br>32 A | <b>934 071-Colour**</b><br>● ● ● ● ● ● |
|         | MLS GG 50/1    | 50 cm            | 1 mm <sup>2</sup> , PVC<br>16 A   | <b>934 072-Colour**</b><br>● ● ● ● ●   |
|         | MLS GG 50/2,5  | 50 cm            | 2,5 mm <sup>2</sup> , PVC<br>32 A | <b>934 073-Colour**</b><br>● ● ● ● ● ● |
|         | MLS GG 100/1   | 100 cm           | 1 mm <sup>2</sup> , PVC<br>16 A   | <b>934 074-Colour**</b><br>● ● ● ● ●   |
|         | MLS GG 100/2,5 | 100 cm           | 2,5 mm <sup>2</sup> , PVC<br>32 A | <b>934 075-Colour**</b><br>● ● ● ● ● ● |
|         | MLS GG 200/1   | 200 cm           | 1 mm <sup>2</sup> , PVC<br>16 A   | <b>934 076-Colour**</b><br>● ● ● ● ●   |
|         | MLS GG 200/2,5 | 200 cm           | 2,5 mm <sup>2</sup> , PVC<br>32 A | <b>934 077-Colour**</b><br>● ● ● ● ● ● |

\* System: (64) = 0.64 mm system / (2) ≙ 2 mm system / (4) ≙ 4 mm system / (●) ≙ 4 mm safety system / (↔) ≙ 4 mm sliding sleeve system

\*\* Colour: ● -100 ● -101 ● -102 ● -103 ● -104 ● -188

# Measuring leads



| *System | Article type   | Length "L" in cm | Technical Data                    | Order no. Colour                       |
|---------|----------------|------------------|-----------------------------------|--|
|         | MLS WG 25/1    | 25 cm            | 1 mm <sup>2</sup> , PVC<br>16 A   | <b>934 078-Colour**</b><br>● ● ● ● ●   |
|         | MLS WG 25/2,5  | 25 cm            | 2,5 mm <sup>2</sup> , PVC<br>32 A | <b>934 079-Colour**</b><br>● ● ● ● ● ● |
|         | MLS WG 50/1    | 50 cm            | 1 mm <sup>2</sup> , PVC<br>16 A   | <b>934 080-Colour**</b><br>● ● ● ● ●   |
|         | MLS WG 50/2,5  | 50 cm            | 2,5 mm <sup>2</sup> , PVC<br>32 A | <b>934 081-Colour**</b><br>● ● ● ● ● ● |
|         | MLS WG 100/1   | 100 cm           | 1 mm <sup>2</sup> , PVC<br>16 A   | <b>934 082-Colour**</b><br>● ● ● ● ●   |
|         | MLS WG 100/2,5 | 100 cm           | 2,5 mm <sup>2</sup> , PVC<br>32 A | <b>934 083-Colour**</b><br>● ● ● ● ● ● |
|         | MLS WG 200/1   | 200 cm           | 1 mm <sup>2</sup> , PVC<br>16 A   | <b>934 084-Colour**</b><br>● ● ● ● ●   |
|         | MLS WG 200/2,5 | 200 cm           | 2,5 mm <sup>2</sup> , PVC<br>32 A | <b>934 085-Colour**</b><br>● ● ● ● ● ● |

\* System: (64) = 0.64 mm system / (2) ≙ 2 mm system / (4) ≙ 4 mm system / (●) ≙ 4 mm safety system / (↔) ≙ 4 mm sliding sleeve system

\*\* Colour: ● -100 ● -101 ● -102 ● -103 ● -104 ● -188

# Measuring leads



| *System | Article type   | Length "L" in cm | Technical Data                    | Order no. Colour                       |
|---------|----------------|------------------|-----------------------------------|--|
|         | MLS WS 25/1    | 25 cm            | 1 mm <sup>2</sup> , PVC<br>16 A   | <b>934 067-Colour**</b><br>● ● ● ● ●   |
|         | MLS WS 25/2,5  | 25 cm            | 2,5 mm <sup>2</sup> , PVC<br>32 A | <b>934 086-Colour**</b><br>● ● ● ● ● ● |
|         | MLS WS 50/1    | 50 cm            | 1 mm <sup>2</sup> , PVC<br>16 A   | <b>934 068-Colour**</b><br>● ● ● ● ●   |
|         | MLS WS 50/2,5  | 50 cm            | 2,5 mm <sup>2</sup> , PVC<br>32 A | <b>934 087-Colour**</b><br>● ● ● ● ● ● |
|         | MLS WS 100/1   | 100 cm           | 1 mm <sup>2</sup> , PVC<br>16 A   | <b>934 095-Colour**</b><br>● ● ● ● ●   |
|         | MLS WS 100/2,5 | 100 cm           | 2,5 mm <sup>2</sup> , PVC<br>32 A | <b>934 088-Colour**</b><br>● ● ● ● ● ● |
|         | MLS WS 200/1   | 200 cm           | 1 mm <sup>2</sup> , PVC<br>16 A   | <b>934 069-Colour**</b><br>● ● ● ● ●   |
|         | MLS WS 200/2,5 | 200 cm           | 2,5 mm <sup>2</sup> , PVC<br>32 A | <b>934 089-Colour**</b><br>● ● ● ● ● ● |

\* System: (64) = 0.64 mm system / (2) ≙ 2 mm system / (4) ≙ 4 mm system / (●) ≙ 4 mm safety system / (↔) ≙ 4 mm sliding sleeve system

\*\* Colour: ● -100 ● -101 ● -102 ● -103 ● -104 ● -188



# Measuring leads

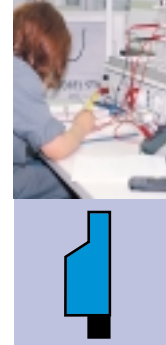

| *System | Article type | Length<br>"L" in cm | Technical<br>Data                 | Order no.<br>Colour                        |
|---------|--------------|---------------------|-----------------------------------|--|
|         | MLN 25/1     | 25 cm               | 1 mm <sup>2</sup> , PVC<br>16 A   | <b>934 058-Colour**</b><br>● ● ● ● ● ●     |
|         | MLN 25/2,5   | 25 cm               | 2,5 mm <sup>2</sup> , PVC<br>32 A | <b>934 059-Colour**</b><br>● ● ● ● ● ● ● ● |
|         | MLN 50/1     | 50 cm               | 1 mm <sup>2</sup> , PVC<br>16 A   | <b>934 060-Colour**</b><br>● ● ● ● ● ●     |
|         | MLN 50/2,5   | 50 cm               | 2,5 mm <sup>2</sup> , PVC<br>32 A | <b>934 061-Colour**</b><br>● ● ● ● ● ● ● ● |
|         | MLN 100/1    | 100 cm              | 1 mm <sup>2</sup> , PVC<br>16 A   | <b>934 062-Colour**</b><br>● ● ● ● ● ●     |
|         | MLN 100/2,5  | 100 cm              | 2,5 mm <sup>2</sup> , PVC<br>32 A | <b>934 063-Colour**</b><br>● ● ● ● ● ● ● ● |
|         | MLN 150/1    | 150 cm              | 1 mm <sup>2</sup> , PVC<br>16 A   | <b>934 064-Colour**</b><br>● ● ● ● ● ●     |
|         | MLN 200/1    | 200 cm              | 1 mm <sup>2</sup> , PVC<br>16 A   | <b>934 065-Colour**</b><br>● ● ● ● ● ●     |
|         | MLN 200/2,5  | 200 cm              | 2,5 mm <sup>2</sup> , PVC<br>32 A | <b>934 066-Colour**</b><br>● ● ● ● ● ● ● ● |

\* System: (64) = 0.64 mm system / (2) ≙ 2 mm system / (4) ≙ 4 mm system / (●) ≙ 4 mm safety system / (↔) ≙ 4 mm sliding sleeve system

\*\* Colour: ● -100 ● -101 ● -102 ● -103 ● -104 ● -188

# Measuring leads

| *System |  | Article type  | Length<br>"L" in cm | Technical<br>Data                                | Order no.<br>Colour                        |
|---------|--|---------------|---------------------|--|--|
| ④       |  | MLN SIL 25/1  | 25 cm               | 1 mm <sup>2</sup> , Silicon<br>16 A              | <b>934 090-Colour**</b><br>● ● ● ● ● ●     |
|         |  | MLN SIL 50/1  | 50 cm               | 1 mm <sup>2</sup> , Silicon<br>16 A              | <b>934 091-Colour**</b><br>● ● ● ● ● ●     |
|         |  | MLN SIL 100/1 | 100 cm              | 1 mm <sup>2</sup> , Silicon<br>16 A              | <b>934 092-Colour**</b><br>● ● ● ● ● ●     |
|         |  | MLN SIL 150/1 | 150 cm              | 1 mm <sup>2</sup> , Silicon<br>16 A              | <b>934 093-Colour**</b><br>● ● ● ● ● ●     |
|         |  | MLN SIL 200/1 | 200 cm              | 1 mm <sup>2</sup> , Silicon<br>16 A              | <b>934 094-Colour**</b><br>● ● ● ● ● ●     |
| ⊕       |  | MLB 25/1 V    | 25 cm               | 1 mm <sup>2</sup> , PVC<br>16 A<br>60 V DC       | <b>973 644-Colour**</b><br>● ● ● ● ● ●     |
|         |  | MLB 50/1 V    | 50 cm               | 1 mm <sup>2</sup> , PVC<br>16 A<br>60 V DC       | <b>973 645-Colour**</b><br>● ● ● ● ● ●     |
|         |  | MLB 100/1 V   | 100 cm              | 1 mm <sup>2</sup> , PVC<br>16 A<br>60 V DC       | <b>973 646-Colour**</b><br>● ● ● ● ● ● ● ● |
|         |  | MLB 200/1 V   | 200 cm              | 1 mm <sup>2</sup> , PVC<br>16 A<br>60 V DC       | <b>973 647-Colour**</b><br>● ● ● ● ● ●     |
| ⊙       |  | PL 2600 S W   | 100 cm              | 1 mm <sup>2</sup> , PVC<br>16 A<br>Angle plug    | <b>934 158-Colour**</b><br>● ●             |
|         |  | PL 2600 S     | 100 cm              | 1 mm <sup>2</sup> , PVC<br>16 A<br>Straight plug | <b>934 159-Colour**</b><br>● ●             |

\* System: ④ = 0.64 mm system / ② ≙ 2 mm system / ④ ≙ 4 mm system / ⊙ ≙ 4 mm safety system / ⊕ ≙ 4 mm sliding sleeve system

\*\* Colour: ● -100 ● -101 ● -102 ● -103 ● -104 ● -188





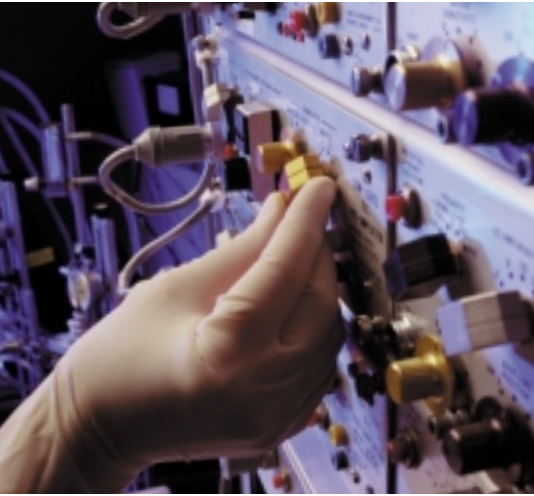







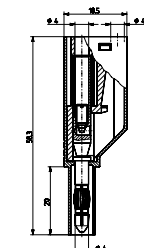

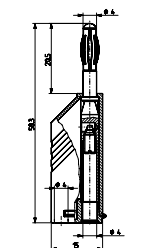

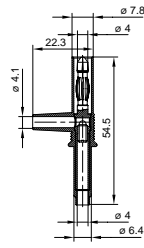
# Plugs

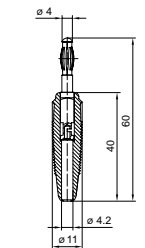

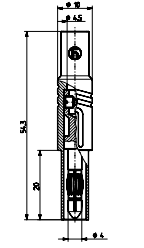
## Product description

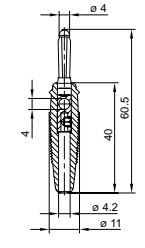

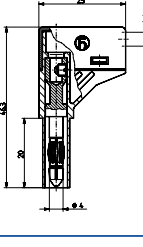

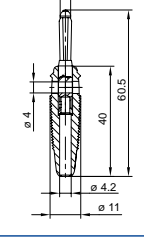





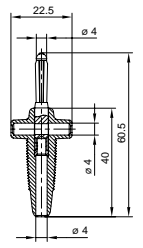

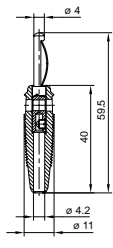

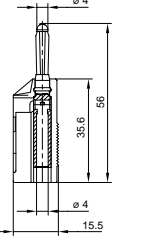

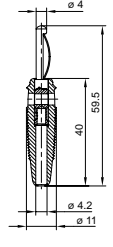

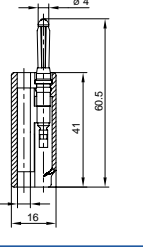
Plugs and connectors permit users to assemble their own measuring and testing leads. A variety of contact-making and connecting systems offer the ideal solution for every application. Safety plugs with screw connectors comply with IEC 1010 and can be used for voltages up to 1000 V. Connectors permit the assembly of extensions and connecting leads. All the products are simply plugged, screwed or soldered

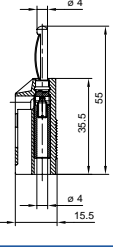
together without the need for specialised tools.

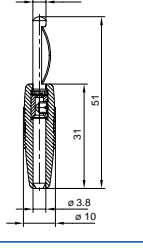
| *System Article type   | Technical Data   | Order no. Colour  | *System Article type  | Technical Data  | Order no. Colour  |
|--|--|---|---|---|---|
| <br>LAS S WS     | <br>20 A screw connection up to 1.5 mm <sup>2</sup>  | 934 099-100 ●<br>934 099-101 ●<br>934 099-102 ●<br>934 099-103 ●<br>934 099-104 ● | <br>LAS N WS    | <br>20 A screw connection up to 1.5 mm <sup>2</sup> | 934 100-100 ●<br>934 100-101 ●<br>934 100-102 ●<br>934 100-103 ●<br>934 100-104 ● |
| <br>SLS 2000 SH | <br>25 A screw connection up to 2.5 mm <sup>2</sup> | 972 320-100 ●<br>972 320-101 ●  | <br>LAS 30     | <br>20 A solder contact up to 1.5 mm <sup>2</sup>  | 972 518-100 ●<br>972 518-101 ●  |
| <br>LAS S G     | <br>20 A screw connection max. 1.5 mm <sup>2</sup>  | 934 097-100 ●<br>934 097-101 ●<br>934 097-102 ●<br>934 097-103 ●<br>934 097-104 ● | <br>BUELA 20 K | <br>16 A screw connection max. 1.5 mm <sup>2</sup> | 930 726-100 ●<br>930 726-101 ●<br>930 726-102 ●<br>930 726-103 ●<br>930 726-104 ● |
| <br>LAS S W     | <br>20 A screw connection up to 1.5 mm <sup>2</sup> | 934 098-100 ●<br>934 098-101 ●<br>934 098-102 ●<br>934 098-103 ●<br>934 098-104 ● | <br>BUELA 30 K | <br>30 A solder contact max. 2.5 mm <sup>2</sup>   | 930 727-100 ●<br>930 727-101 ●<br>930 727-102 ●<br>930 727-103 ●<br>930 727-104 ● |

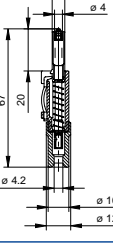
\* System: (64) = 0.64 mm system / (2) ≙ 2 mm system / (4) ≙ 4 mm system / (●) ≙ 4 mm safety system / (↔) ≙ 4 mm sliding sleeve system

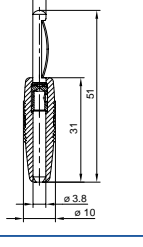

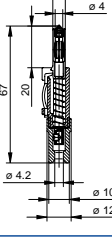







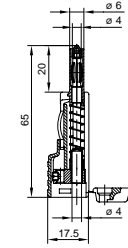

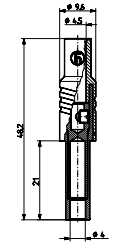

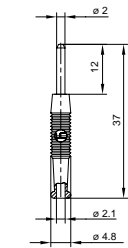

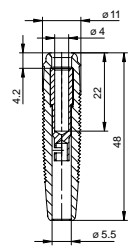

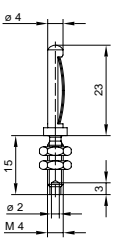

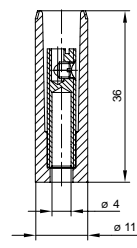
| *System Article type   | Technical Data   | Order no. Colour  | *System Article type  | Technical Data  | Order no. Colour  |
|--|--|---|---|---|---|
| (4) <br>BUELA 300 K |  <p>30 A solder contact max. 2.5 mm<sup>2</sup></p>     | 931 667-100 ●<br>931 667-101 ●<br>931 667-102 ●<br>931 667-103 ●<br>931 667-104 ● | (4) <br>VQ 20      |  <p>16 A screw connection max. 1.5 mm<sup>2</sup></p>          | 930 058-100 ●<br>930 058-101 ●<br>930 058-102 ●<br>930 058-103 ●<br>930 058-104 ● |
| (4) <br>BSB 20 K   |  <p>30 A screw connection max. 2.5 mm<sup>2</sup></p>  | 930 729-100 ●<br>930 729-101 ●<br>930 729-102 ●<br>930 729-103 ●<br>930 729-104 ● | (4) <br>VQ 30     |  <p>30 A solder contact max. 2.5 mm<sup>2</sup></p>           | 930 061-100 ●<br>930 061-101 ●<br>930 061-102 ●<br>930 061-103 ●<br>930 061-104 ● |
| (4) <br>BSB 300   |  <p>16 A solder contact max. 1.5 mm<sup>2</sup></p>   | 931 294-100 ●<br>931 294-101 ●  | (4) <br>VSB 20   |  <p>30 A screw connection max. 2.5 mm<sup>2</sup></p>        | 930 435-100 ●<br>930 435-101 ●<br>930 435-102 ●<br>930 435-103 ●<br>930 435-104 ● |
| (4) <br>VON 20    |  <p>16 A screw connection max. 1.5 mm<sup>2</sup></p> | 930 046-100 ●<br>930 046-101 ●<br>930 046-102 ●<br>930 046-103 ●<br>930 046-104 ● | (↔) <br>SLS 10 B |  <p>30 A 60 V DC</p>   | 931 824-100 ●<br>931 824-101 ●  |
| (4) <br>VON 30    |  <p>30 A solder contact max. 2.5 mm<sup>2</sup></p>   | 930 047-100 ●<br>930 047-101 ●<br>930 047-102 ●<br>930 047-103 ●<br>930 047-104 ● | (↔) <br>SLS 20 B |  <p>16 A 300 V screw connection up to 1.5 mm<sup>2</sup></p> | 931 825-100 ●<br>931 825-101 ●  |

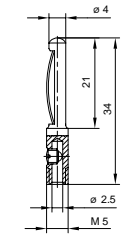
\* System: (64) = 0.64 mm system / (2) ≙ 2 mm system / (4) ≙ 4 mm system / ● ≙ 4 mm safety system / (↔) ≙ 4 mm sliding sleeve system

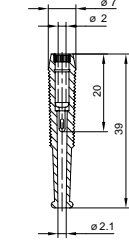

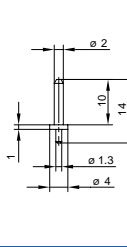

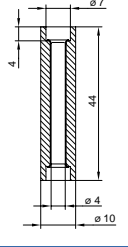



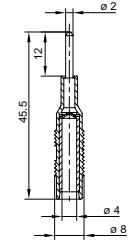

# Plugs

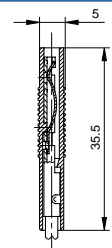

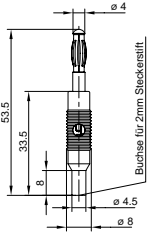
| *System Article type   | Technical Data  | Order no. Colour   | *System Article type  | Technical Data  | Order no. Colour  |
|--|---|--|---|---|---|
| <br>SLS 200   |  <p>30 A<br/>300 V<br/>screw<br/>connection<br/>up to<br/>2.5 mm<sup>2</sup></p> | 932 153-100 ●<br>932 153-101 ●   | <br>KUN S    |    | 934 096-100 ●<br>934 096-101 ●<br>934 096-102 ●<br>934 096-103 ●<br>934 096-104 ● |
| <br>MST 3    |  <p>6 A<br/>solder<br/>contact</p>  | 973 509-100 ●<br>973 509-101 ●<br>973 509-102 ●<br>973 509-103 ●<br>973 509-104 ●<br>973 509-106 ● | <br>KUN 30  |  <p>16 A<br/>solder<br/>contact<br/>up to<br/>2.5 mm<sup>2</sup></p>    | 931 804-100 ●<br>931 804-101 ●<br>931 804-102 ●<br>931 804-103 ●<br>931 804-104 ● |
| <br>VST 20  |  <p>16 A<br/>solder<br/>contact<br/>max.<br/>2 mm<sup>2</sup></p>              | 930 050-000  | <br>KUN 10 |  <p>16 A<br/>screw<br/>connection<br/>up to<br/>1.5 mm<sup>2</sup></p> | 930 189-100 ●<br>930 189-101 ●  |
| <br>VST 100 |  <p>16 A<br/>screw<br/>connection<br/>max.<br/>1.5 mm<sup>2</sup></p>          | 930 581-000  | <br>MKU 1  |  <p>6 A</p>  | 930 320-100 ●<br>930 320-101 ●  |
| <br>MST 201 |    | 931 338-001  | <br>KD 10  |  <p>10 A</p>   | 930 109-100 ●<br>930 109-101 ●  |

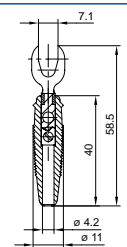
\* System: (64) = 0.64 mm system / (2) ≙ 2 mm system / (4) ≙ 4 mm system / (●) ≙ 4 mm safety system / (↔) ≙ 4 mm sliding sleeve system

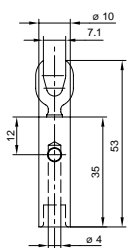

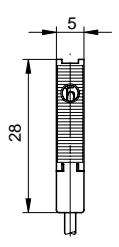
| *System<br>Article type  | Technical<br>Data   | Order no.<br>Colour   | *System<br>Article type   | Technical<br>Data  | Order no.<br>Colour  |
|--|---|---|---|--|--|
| (2) (4)<br><br>MZS 2  |    | 6 A<br>973 600-100 ●<br>973 600-101 ●   | <br>FLAK 6,3 |  | 16 A for tab<br>connectors<br>6.3 x 0.8<br>complying<br>with<br>DIN 46 244<br>crimp<br>connection<br>1.5 mm <sup>2</sup> up<br>to 2.5 mm <sup>2</sup><br>909 004-100 ●<br>909 004-101 ●<br>909 004-107 ○ |
| (4) (2)<br><br>MZS 4 |   | 6 A<br>973 599-100 ●<br>973 599-101 ●   |   |  |  |
| <br>KB 2            |  | 30 A<br>max.<br>2.5 mm <sup>2</sup><br>930 584-100 ●<br>930 584-101 ●   |   |  |  |
| (4)<br><br>KB 20    |  | 30 A<br>930 110-100 ●<br>930 110-101 ●  |   |  |  |
| <br>FLAK 2,8        |  | 12 A for tab<br>connectors<br>2.8 x 0.8 and<br>2.8 x 0.5<br>complying<br>with<br>DIN 46 244<br>crimp<br>connection<br>0.5 mm <sup>2</sup> up<br>to 0.75 mm <sup>2</sup><br>909 009-100 ●<br>909 009-101 ● |   |  |  |

\* System: (64) = 0.64 mm system / (2) ≙ 2 mm system / (4) ≙ 4 mm system / ● ≙ 4 mm safety system / ↔ ≙ 4 mm sliding sleeve system

# Sockets













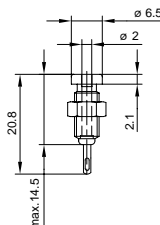

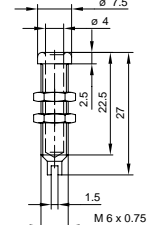

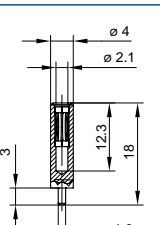
## Product description

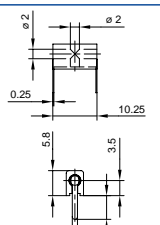
Sockets are built in equipment, housings or panels and permit the rapid, simple connection of measuring leads, plugs or, when configured as pole terminals, the secondary connection of leads and cable lugs.

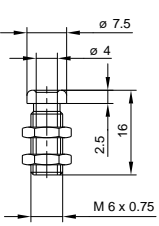
Tin plated and gold plated surfaces, and a choice of connector cross sections, permit the reliable transmission of low-level signals and powerful currents.

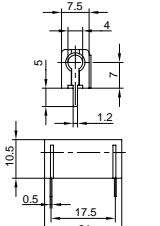
The insulation of the PKI 110 incorporates a spring which

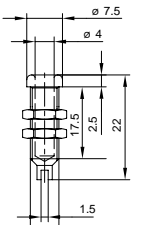

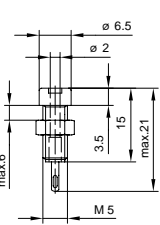







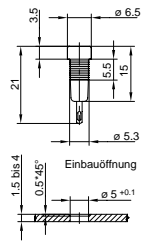

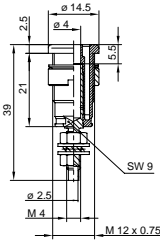

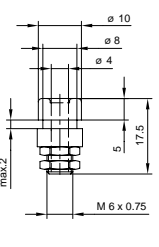

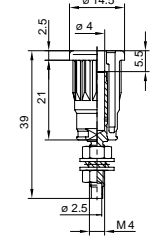

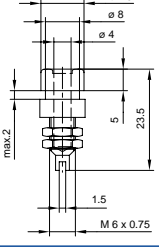
permits leads to be efficiently connected in the minimum of time.

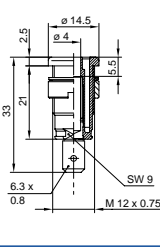
| *System Article type   | Technical Data  | Order no. Colour  | *System Article type   | Technical Data  | Order no. Colour  |
|--|---|---|--|---|---|
| (2) <br>MBU 1  |   | 6 A<br>930 312-000  | (4) <br>BU 20  |   | 16 A opening for installation $\varnothing$ 6 mm<br>930 177-000   |
| (2) <br>MBU 2 |  | 6 A<br>931 337-000  | (2) <br>MPB 1 |  | 6 A<br>930 224-100 ●<br>930 224-101 ●   |
| (4) <br>BO 10 |  | 16 A opening for installation $\varnothing$ 6 mm<br>930 160-000 | (4) <br>PB 4  |  | 16 A<br>973 582-100 ●<br>973 582-101 ●  |
| (4) <br>BU 10 |  | 16 A opening for installation $\varnothing$ 6 mm<br>930 147-000 | (2) <br>MBI 1 |  | 6 A<br>930 308-100 ●<br>930 308-101 ●<br>930 308-102 ●<br>930 308-103 ●<br>930 308-104 ●<br>930 308-106 ● |

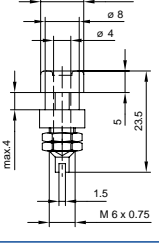
\* System: (64) = 0.64 mm system / (2)  $\hat{=}$  2 mm system / (4)  $\hat{=}$  4 mm system / (●)  $\hat{=}$  4 mm safety system / (↔)  $\hat{=}$  4 mm sliding sleeve system

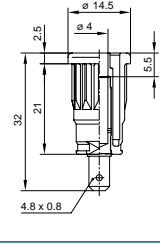

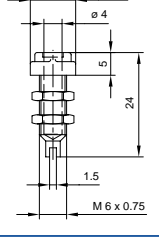

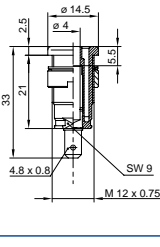







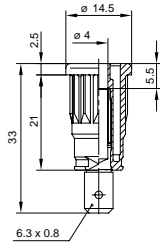

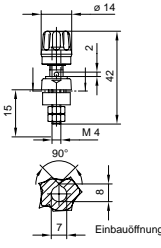

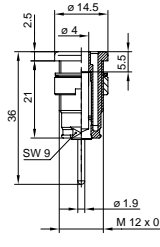

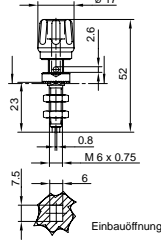

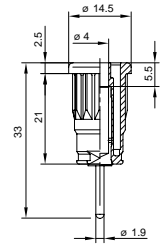

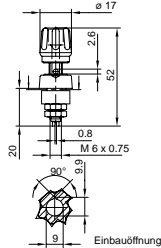
| *System Article type  | Technical Data  | Order no. Colour   | *System Article type   | Technical Data   | Order no. Colour   |
|---|---|--|--|--|--|
| <br>MBI 2    |  <p>6 A press-fit sleeve</p>   | 973 642-100 ●<br>973 642-101 ●   | <br>SEB 2600 G M4   |  <p>32 A screw connection, M4, solder</p>                    | 972 354-100 ●<br>972 354-101 ●<br>972 354-102 ●<br>972 354-103 ●<br>972 354-104 ●<br>972 354-188 ● |
| <br>BI 20   |  <p>max. 32 A opening for installation <math>\varnothing</math> 8 mm</p>  | 930 164-100 ●<br>930 164-101 ●   | <br>SEP 2600-G M4  |  <p>32 A screw connection, M4, solder, press-fit sleeve</p> | 972 360-100 ●<br>972 360-101 ●<br>972 360-102 ●<br>972 360-103 ●<br>972 360-104 ●<br>972 360-188 ● |
| <br>BIL 20 |  <p>max. 32 A opening for installation <math>\varnothing</math> 8 mm</p> | 930 176-100 ●<br>930 176-101 ●<br>930 176-102 ●<br>930 176-103 ●<br>930 176-104 ●<br>930 176-107 ○ | <br>SEB 2610 F4,8 |  <p>24 A 4.8 x 0.8, tab connector</p>                      | 972 355-100 ●<br>972 355-101 ●<br>972 355-102 ●<br>972 355-103 ●<br>972 355-104 ●<br>972 355-188 ● |
| <br>BIL 30 |  <p>max. 32 A opening for installation <math>\varnothing</math> 8 mm</p> | 930 166-100 ●<br>930 166-101 ●   | <br>SEP 2610-F4,8 |  <p>24 A press-fit sleeve, tab connector 4.8 x 0.8</p>     | 972 361-100 ●<br>972 361-101 ●<br>972 361-102 ●<br>972 361-103 ●<br>972 361-104 ●<br>972 361-188 ● |
| <br>BUG 10 |  <p>max. 32 A opening for installation <math>\varnothing</math> 6 mm</p> | 930 175-100 ●<br>930 175-101 ●<br>930 175-102 ●<br>930 175-103 ●<br>930 175-104 ●                  | <br>SEB 2620 F6,3 |  <p>32 A 6.3 x 0.8, tab connector</p>                      | 972 356-100 ●<br>972 356-101 ●<br>972 356-102 ●<br>972 356-103 ●<br>972 356-104 ●<br>972 356-188 ● |

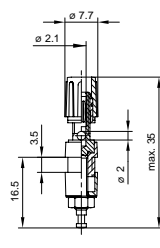
\* System: (64) = 0.64 mm system / (2) = 2 mm system / (4) = 4 mm system / (●) = 4 mm safety system / (↔) = 4 mm sliding sleeve system

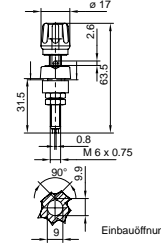

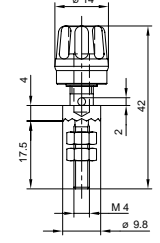

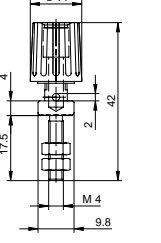

# Sockets

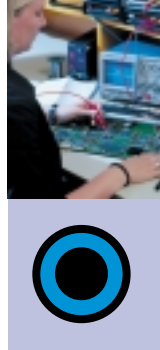

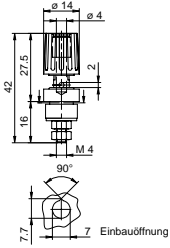
| *System Article type   | Technical Data  | Order no. Colour  | *System Article type   | Technical Data   | Order no. Colour  |
|--|---|---|--|--|---|
|  <p>SEP 2620-F6,3</p>   |  <p>32 A press-in socket, tab connector 6.3 x 0.8</p>  | <p>972 362-100 ●</p> <p>972 362-101 ●</p> <p>972 362-102 ●</p> <p>972 362-103 ●</p> <p>972 362-104 ●</p> <p>972 362-188 ●</p> |  <p>PKI 10 A</p>    |  <p>max. 35 A</p>                                   | <p>930 103-100 ●</p> <p>930 103-101 ●</p> <p>930 103-102 ●</p> <p>930 103-103 ●</p> <p>930 103-104 ●</p> <p>930 103-188 ●</p> |
|  <p>SEB 2630-S1,9</p>  |  <p>24 A soldering spike 1.9 mm</p>                   | <p>972 359-100 ●</p> <p>972 359-101 ●</p> <p>972 359-102 ●</p> <p>972 359-103 ●</p> <p>972 359-104 ●</p> <p>972 359-188 ●</p> |  <p>PKN 10 B</p>   |  <p>63 A</p>                                       | <p>930 117-100 ●</p> <p>930 117-101 ●</p>   |
|  <p>SEP 2630-S1,9</p> |  <p>24 A press-in socket, soldering spike 1.9 mm</p> | <p>972 363-100 ●</p> <p>972 363-101 ●</p> <p>972 363-102 ●</p> <p>972 363-103 ●</p> <p>972 363-104 ●</p> <p>972 363-188 ●</p> |  <p>PKNI 10 B</p> |  <p>63 A</p>                                      | <p>930 136-100 ●</p> <p>930 136-101 ●</p>   |
|  <p>MPK 1</p>         |  <p>6 A</p>  | <p>930 268-100 ●</p> <p>930 268-101 ●</p>   |  <p>PKNI 20 B</p> |  <p>63 A</p>                                      | <p>930 144-100 ●</p> <p>930 144-101 ●</p>   |
|  <p>PK 10 A</p>       |  <p>max. 35 A opening for installation ø 6 mm</p>    | <p>930 099-100 ●</p> <p>930 099-101 ●</p> <p>930 099-102 ●</p> <p>930 099-103 ●</p> <p>930 099-104 ●</p> <p>930 099-188 ●</p> |  <p>PK 110</p>    |  <p>max. 35 A opening for installation ø 6 mm</p> | <p>931 713-100 ●</p> <p>931 713-101 ●</p>   |

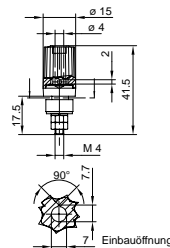
\* System: (64) = 0.64 mm system / (2) ≙ 2 mm system / (4) ≙ 4 mm system / (●) ≙ 4 mm safety system / (↔) ≙ 4 mm sliding sleeve system

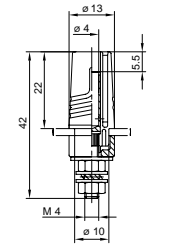

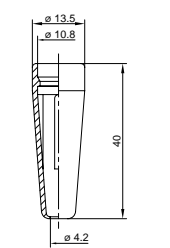
| *System<br>Article type   | Technical<br>Data  | Order no.<br>Colour   | Notes |
|---|--|---|-------|
| <p>④</p>  <p>PKI 110</p>            | max. 35 A  | <p>931 714-100 ●</p> <p>931 714-101 ●</p> <p>931 714-102 ●</p> <p>931 714-103 ●</p> <p>931 714-104 ●</p> <p>931 714-188 ●</p> |       |
| <p>④</p>  <p>PKI 100</p>          | max. 35 A  | <p>930 757-100 ●</p> <p>930 757-101 ●</p> <p>930 757-102 ●</p> <p>930 757-103 ●</p> <p>930 757-104 ●</p> <p>930 757-188 ●</p> |       |
| <p>⊙</p>  <p>SAB 2600 G M4</p>  | 32 A<br>surface-mounted socket,<br>screw connection,<br>M4         | <p>972 357-100 ●</p> <p>972 357-101 ●</p> <p>972 357-102 ●</p> <p>972 357-103 ●</p> <p>972 357-104 ●</p> <p>972 357-188 ●</p> |       |
| <p>⊙</p>  <p>BES 1000</p>       | Contact protection for screw-in and press-in sockets (SEB and SEP) | 973 616-103 ●   |       |
|   |  |   |       |

\* System: ⑥4 = 0.64 mm system / ② ≙ 2 mm system / ④ ≙ 4 mm system / ⊙ ≙ 4 mm safety system / ⊕ ≙ 4 mm sliding sleeve system

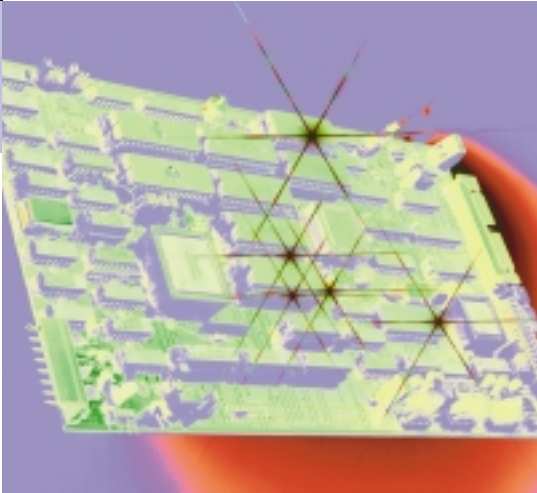

# IC testers



## Product description

IC testers serve as adapters for testing of soldered ICs with SOIC, PLCC and JEDEC type housings.

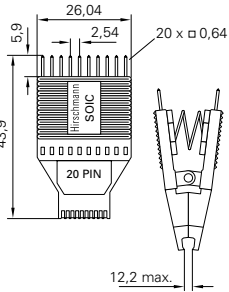
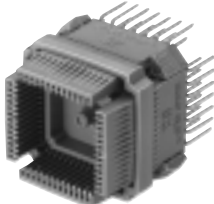
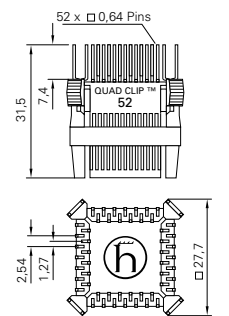
By means of a retaining mechanism, testers can be securely connected to a specimen for testing with a test instrument. A variety numbers of poles cover the most commonly used types. Thanks to the compact size of the testers, even printed circuit boards with densely mounted components can be tested.

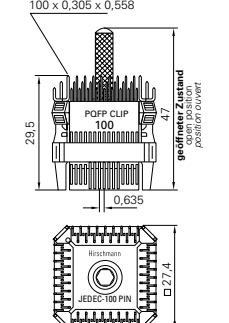
| Type  |   | Number of poles   | Order no.  |
|---|---|---|--|
|   |   | SOIC-T-8<br>SOIC-T-14<br>SOIC-T-16<br>SOIC-T-20<br>SOIC-T-24                            | 8<br>14<br>16<br>20<br>24<br>IC tester (8- to 24-pole)<br>for SMD-SOIC and SOJ<br>with 1.27 mm pin spacing               |
|  |  | PLCC-T-20<br>PLCC-T-28<br>PLCC-T-32<br>PLCC-T-44<br>PLCC-T-52<br>PLCC-T-68<br>PLCC-T-84 | 20<br>28<br>32<br>44<br>52<br>68<br>84<br>IC tester (20- to 84-pole)<br>for SMD-PLCC and PCC<br>with 1.27 mm pin spacing |
|  |  | JEDEC-T-100<br>JEDEC-T-132<br>JEDEC-T-196   | 100<br>132<br>196<br>IC tester (100- to 196-pole)<br>for SMD-JEDEC QFP<br>with 0.635 mm pin spacing                      |

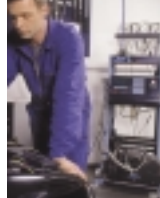

## Product description

Sets are composed of products which serve as the basic equipment for specific applications. A set contains products from a system, e.g. measuring leads, test probes, crocodile clips, etc., coloured red and black in each case. Sets also serve as the basic equipment and provide expansion facilities for multimeters:

- Original electronic equipment (PMS 0.64)
- Vehicle service set (PMS 4 KFZ)
- Safety set for electricians (PMS 2600)



|                        |   |                  |  |
|------------------------|---|------------------|--|
| <p>PL 2600 S W Set</p> | <p><b>Test probe set as accessory for measuring devices</b></p> <ul style="list-style-type: none"> <li>• Test lead with dual function test probe PL 2600 S W; **</li> </ul> <p><b>Order no.: 972 425-002</b></p>  | <p>PMS 2</p>     | <p><b>Test equipment set for 2 mm miniature system</b></p> <ul style="list-style-type: none"> <li>• KLEPS 2 BU clamp-type test probe; **</li> <li>• MPS 1 miniature test probe; **</li> <li>• MA 1 miniature crocodile clip; **</li> <li>• MVL 2/100 measuring lead; **</li> </ul> <p><b>Order no.: 932 961-001</b></p>  |
| <p>PL 2600 S Set</p>   | <p><b>Test probe set as accessory for measuring devices</b></p> <ul style="list-style-type: none"> <li>• Test lead with dual function test probe PL 2600 S; **</li> </ul> <p><b>Order no.: 972 337-002</b></p>  | <p>PMS 4</p>     | <p><b>Test equipment set for 4 mm system</b></p> <ul style="list-style-type: none"> <li>• KLEPS 30 clamp-type test probe; **</li> <li>• PRUEF 2 test probe; **</li> <li>• AK 2 S crocodile clip; **</li> <li>• MLN 100/1 measuring lead; **</li> </ul> <p><b>Order no.: 932 793-001</b></p>  |
| <p>PMS 0,64</p>        | <p><b>Micro test equipment set for SMD components and 0.64 mm miniature system</b></p> <ul style="list-style-type: none"> <li>• MICRO-KLEPS micro clamp-type test probe; **</li> <li>• MICRO-PRUEF MPS 2/0.64 FT sprung micro test probe; **</li> <li>• AGF 1 crocodile clip; *</li> <li>• MALN 4-0.64/100-0.25 measuring lead from 0.64 mm to 4 mm; **</li> </ul> <p><b>Order no.: 932 959-001</b></p> | <p>PMS 4 KFZ</p> | <p><b>Test equipment set for automobile service and workshops, 4 mm system</b></p> <ul style="list-style-type: none"> <li>• KLEPS 2700 piercing clip; **</li> <li>• PRUEF 2610 FT sprung test probe; **</li> <li>• AK 2 B 2540 crocodile clip; **</li> <li>• MLN SIL 150/1 silicon measuring lead; **, lead length 1.5 m</li> </ul> <p><b>Order no.: 933 003-001</b></p> |

\* 1 each blank, \*\* 1 each red and 1 each black



|   |   |  |  |
|---|---|--|--|
|  <p>PMS 250</p>   | <p><b>Sliding sleeve test equipment set for 4 mm system</b></p> <ul style="list-style-type: none"> <li>• KLEPS 250 clamp-type test probe; **</li> <li>• PRUEF 2 S test probe; **</li> <li>• AK 2 B crocodile clip; **</li> <li>• MLB 100/1 V measuring lead; **</li> </ul> <p><b>Order no.: 932 827-001</b></p>               |  <p>MMS 2020</p>  | <p><b>Multimeter set as accessory for measuring devices</b></p> <ul style="list-style-type: none"> <li>• PRUEF 2700 test probe; **</li> <li>• AK 2 B 2540 crocodile clip; **</li> <li>• MLS WG 100/1 contact-protected measuring lead; **</li> </ul> <p><b>Order no.: 972 340-001</b></p>  |
|  <p>PMS 2600</p> | <p><b>Test equipment set for safety applications</b></p> <ul style="list-style-type: none"> <li>• KLEPS 2600 clamp-type test probe; **</li> <li>• PRUEF 2600 test probe; **</li> <li>• AK 2 B crocodile clip; **</li> <li>• MLS GG 100/1 contact-protected measuring lead; **</li> </ul> <p><b>Order no.: 972 338-001</b></p> |  <p>MMS 2030</p> | <p><b>Multimeter set as accessory for measuring devices</b></p> <ul style="list-style-type: none"> <li>• KLEPS 2600 clamp-type test probe; **</li> <li>• PRUEF 2700 test probe; **</li> <li>• MLS WG 100/1 contact-protected measuring lead; **</li> </ul> <p><b>Order no.: 972 341-001</b></p>                                  |
|  <p>MMS 2010</p> | <p><b>Multimeter set as accessory for measuring devices</b></p> <ul style="list-style-type: none"> <li>• KLEPS 2800 clamp-type test probe; **</li> <li>• PRUEF 2700 test probe; **</li> <li>• MLS WG 100/1 contact-protected measuring lead; **</li> </ul> <p><b>Order no.: 972 339-001</b></p>                               |  <p>MMS 2040</p> | <p><b>Multimeter set as accessory for measuring devices</b></p> <ul style="list-style-type: none"> <li>• KLEPS 2600 clamp-type test probe; **</li> <li>• AK 2 B crocodile clip; **</li> <li>• PL 2600 test lead; **</li> <li>• MLS WG 100/1 contact-protected measuring lead; **</li> </ul> <p><b>Order no.: 972 342-001</b></p> |

\*\* 1 each red and 1 each black

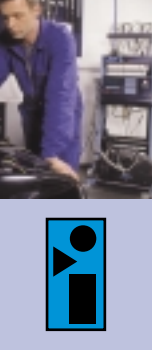

## Warranty clause

Our written and verbal advice in respect of applications is intended to assist you in your work.

It is not binding, even as regards any thirdparty proprietary rights, and does not discharge you from your obligation to carry out corresponding tests determining the suitability of your products for the intended processes and purposes.

Product descriptions do not give any indication as to liability for any damage that may be caused. Should liability arise nevertheless, it is limited to no more than the value of the goods supplied and used, regardless of the damage.

Hirschmann Electronics GmbH & Co.  
Automation and Network Solutions



## Hirschmann. Solutions for communication.

### Germany

Hirschmann Electronics GmbH & Co.  
Automation and Network Solutions  
Stuttgarter Straße 45-51  
D-72654 Neckartenzlingen  
Postfach 1649  
D-72606 Nürtingen  
Tel +49-7127-14-1479/-1480  
Fax +49-7127-14-1495/-1496/-1502  
E-mail: ans-hi-line@nt.hirschmann.de  
<http://www.hirschmann.com>

### Austria

Hirschmann Austria GmbH  
Oberer Paspelsweg 6-8  
A-6830 Rankweil-Brederis  
Tel +43-55 22 307-0  
Fax +43-55 22 307-555  
E-mail: info@rw.hirschmann.at

### Switzerland

Richard Hirschmann GmbH & Co.  
Neckartenzlingen  
Niederlassung Uster  
Seestraße 16  
CH-8610 Uster  
Tel +41-1-905 82 82  
Fax +41-1-905 82 89  
E-mail: ans\_ch@hirschmann.ch

### France

Richard Hirschmann Electronique S.A.  
24, rue du Fer à Cheval, Z.I.  
F-95200 Sarcelles  
Tel +33-1-39 33 02 80  
Fax +33-1-39 90 59 68  
E-mail: ans@hirschmann.fr

### Great Britain

Richard Hirschmann Electronics UK Ltd.  
St. Martins Way  
St. Martins Business Centre  
GB-Bedford MK42 OLF  
Tel +44-1234-34 59 99  
Fax +44-1234-35 22 22  
E-mail: enquiry@hirschmann.co.uk

### Netherlands

Richard Hirschmann  
Electronica Nederland B.V.  
Pampuslaan 170  
NL-1380 AB Weesp  
Tel +31-2944-6 25 55  
Fax +31-2944-8 06 39  
E-mail: ans@hirschmann.nl

### Spain

Hirschmann España S.A.  
Calle Trespaderne, 29  
Edificio Barajas I, 2ª Planta  
E-28042 Madrid  
Tel +34-91-74 617 30  
Fax +34-91-74 617 35  
E-mail: hes@hirschmann.es

### Hungary

Hirschmann Hungária  
Híradástechnikai Kft.  
Rokolya u. 1-13  
H-1131 Budapest  
Tel +36-1-349 41 99  
Fax +36-1-329 84 53  
E-mail: hirh.vez@nap-szam.hu

### USA

Richard Hirschmann of America Inc.  
30 Hook Mountain Road – Unit 201  
Pine Brook, New Jersey 07058, USA  
Tel +1-973-830 2000  
Fax +1-973-830 1470  
E-mail: ans@hirschmann-usa.com

### Singapore

Hirschmann Electronics  
(Asia Pacific) Pte. Ltd.  
3 Toh Tuck Link  
#04-01 German Districentre  
Singapore 596228  
Tel +65-4 63 58 55  
Fax +65-4 63 57 55  
E-mail: hirschmann.ap@pacific.net.sg

### China (PRC)

Hirschmann Electronics  
Shanghai Rep. Office  
Room 518, No. 109 Yangdang Road  
Lu Wan District, 200020  
Shanghai, PRC  
Tel +86-21 63 58 51 19  
Fax +86-21 63 58 51 25  
E-mail: hirschsh@public4.sta.net.cn



## X-ON Electronics

Largest Supplier of Electrical and Electronic Components

*Click to view similar products for [Circuit Board Hardware - PCB category](#):*

*Click to view products by [SKS Kontakttechnik manufacturer](#):*

Other Similar products are found below :

[8919-0-00-15-00-00-03-0](#) [0132-0-15-01-30-27-04-0](#) [0135-0-15-01-30-27-04-0](#) [5970-1-15-01-32-14-04-0](#) [0132-0-15-15-30-27-04-0](#) [0135-0-15-15-30-27-04-0](#) [0149-0-15-15-30-27-04-0](#) [MBI 1 BLUE](#) [7305-0-15-15-47-14-10-0](#) [MKU 1 BLACK](#) [MLN 150/1 BLACK](#) [8579-0-15-80-11-27-10-0](#) [8579-1-15-15-11-27-10-0](#) [8637-0-15-15-21-14-10-0](#) [8830-0-15-01-22-14-10-0](#) [8836-0-00-21-00-00-03-0](#) [PRUEF 2 RED](#) [9976-0-00-00-00-00-03-0](#) [1178-0-01-80-00-00-03-0](#) [PW1616](#) [1215-3-05-00-00-00-01-0](#) [1303-0-15-15-47-14-04-0](#) [1404-3](#) [1404-4](#) [1406-4](#) [1407-3](#) [1406-3](#) [1407-4](#) [1408-3](#) [1424-4](#) [1426-3](#) [1427-3](#) [1427-4](#) [1428-3](#) [1419-4](#) [1424-3](#) [1426-4](#) [1428-4](#) [MPS 1 BLACK](#) [1520150-1](#) [1548-103](#) [1801-0-15-15-30-27-04-0](#) [1938-0-00-00-00-00-03-0](#) [1942-0-00-00-00-00-03-0](#) [2101-3-00-44-00-00-07-0](#) [2104-2-01-44-00-00-07-0](#) [2108-2-00-50-00-00-07-0](#) [2108-3-00-44-00-00-07-0](#) [2109-2-00-44-00-00-07-0](#) [2110-2-00-44-00-00-07-0](#)