

LEGEND:
A - 42440 - * * * *
BASE NUMBER ——— PLATING (SEE NOTE 2.)
CIRCUIT SIZE ——— HOUSING MAT'L. & OPTIONS (SEE NOTE 1.)
(02-24)

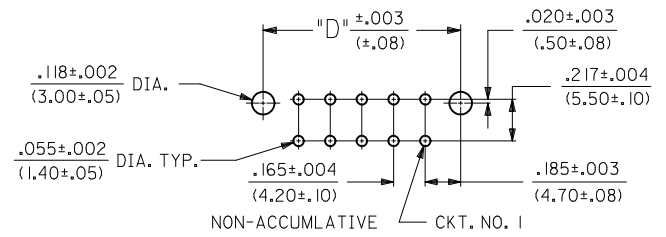

CIRCUIT SIZE	DIM. "A"	DIM. "B"	DIM. "C"	DIM. "D"	DIM. "E"
2	.520 (13.20)	—	.425 (10.80)	.370 (9.40)	.21 (5.4)
4	.685 (17.40)	.17 (4.2)	.590 (15.00)	.535 (13.60)	.38 (9.6)
6	.850 (21.60)	.33 (8.4)	.756 (19.20)	.701 (17.80)	.54 (13.8)
8	1.016 (25.80)	.50 (12.6)	.921 (23.40)	.866 (22.00)	.71 (18.0)
10	1.181 (30.00)	.66 (16.8)	1.087 (27.60)	1.031 (26.20)	.87 (22.2)
12	1.346 (34.20)	.83 (21.0)	1.252 (31.80)	1.197 (30.40)	1.04 (26.4)
14	1.512 (38.40)	.99 (25.2)	1.417 (36.00)	1.362 (34.60)	1.20 (30.6)
16	1.677 (42.60)	1.16 (29.4)	1.583 (40.20)	1.528 (38.80)	1.37 (34.8)
18	1.843 (46.80)	1.32 (33.6)	1.748 (44.40)	1.693 (43.00)	1.54 (39.0)
20	2.008 (51.00)	1.49 (37.8)	1.913 (48.60)	1.858 (47.20)	1.70 (43.2)
22	2.173 (55.20)	1.65 (42.0)	2.079 (52.80)	2.024 (51.40)	1.87 (47.4)
24	2.339 (59.40)	1.82 (46.2)	2.244 (57.00)	2.189 (55.60)	2.03 (51.6)

--*22, --*42	42474--*21, 5556-PBGS*P	94V-0	PHOS. BRZ.	GOLD
--*12, --*32	42474--*11, 5556-PBGS*P	94V-2	PHOS. BRZ.	GOLD
--*22, --*42, --*23, --*43	42474--*21, 5556-GS*P	94V-0	BRASS	GOLD
--*12, --*32, --*13, --*33	42474--*11, 5556-GS*P	94V-2	BRASS	GOLD
--*21, --*41	42474--*21, 5556-PBS*P	94V-0	PHOS. BRZ.	TIN
--*11, --*31	42474--*11, 5556-PBS*P	94V-2	PHOS. BRZ.	TIN
--*21, --*41	42474--*21, 5556-S*P	94V-0	BRASS	TIN
--*11, --*31	42474--*11, 5556-S*P	94V-2	BRASS	TIN
--*22, --*42	A-42385--*D2, --*D4	94V-0	PHOS. BRZ.	GOLD
--*12, --*32	A-42385--*C2, --*C4	94V-2	PHOS. BRZ.	GOLD
--*22, --*42, --*23, --*43	A-42385--*B2, --*B4	94V-0	BRASS	GOLD
--*12, --*32, --*13, --*33	A-42385--*A2, --*A4	94V-2	BRASS	GOLD
--*21, --*41	A-42385--*D1	94V-0	PHOS. BRZ.	TIN
--*11, --*31	A-42385--*C1	94V-2	PHOS. BRZ.	TIN
--*21, --*41	A-42385--*B1	94V-0	BRASS	TIN
--*11, --*31	A-42385--*A1	94V-2	BRASS	TIN
VERT. HEADER A-42440	MATING CONNECTOR	HSG. MAT'L. TERM. MAT'L. PLATING	MATING CONNECTOR FEATURES	

RMV LEAD FREE PN EC NO: UCP2010-1524 DRWN: JAGUILAR CHKD: BELL APPR: FSMITH Q2	DESCRIPTION 2011/01/11 2011/01/11 2011/02/11	QUALITY SYMBOLS	GENERAL TOLERANCES (UNLESS SPECIFIED)	DIMENSION STYLE	SCALE	DESIGN UNITS	THIRD ANGLE PROJECTION
		$\nabla = 0$ $\nabla = 0$ $\nabla = 0$	mm INCH 4 PLACES ± --- ± --- 3 PLACES ± --- ± .010 2 PLACES ± 0.25 ± .015 1 PLACE ± 0.38 ± --- ANGULAR ± 5°	IN/MM DRAWN BY DATE GEP 1989/04/06 CHECKED BY DATE RJF 1989/04/06 APPROVED BY DATE FSMITH 2011/02/11	TITLE MINI-FIT B.M.I. VERTICAL HEADER ASSY WITH DRAIN HOLE OPTION	MOLEX MOLEX INCORPORATED	SHEET NO. 1 OF 5
		DRAFT WHERE APPLICABLE MUST REMAIN WITHIN DIMENSIONS	MATERIAL NO. SEE CHART	DOCUMENT NO. SDA-42440-****	SHEET NO. 1 OF 5		
		THIS DRAWING CONTAINS INFORMATION THAT IS PROPRIETARY TO MOLEX INCORPORATED AND SHOULD NOT BE USED WITHOUT WRITTEN PERMISSION					

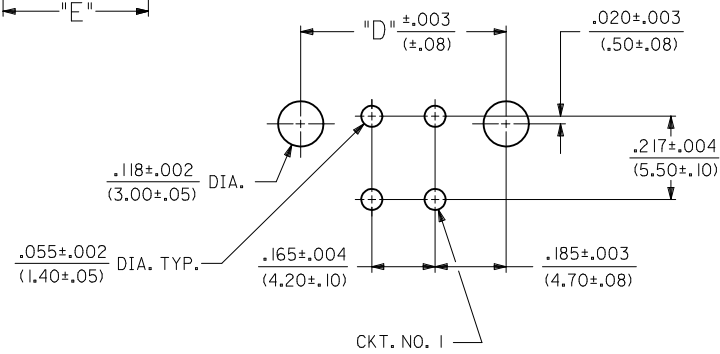
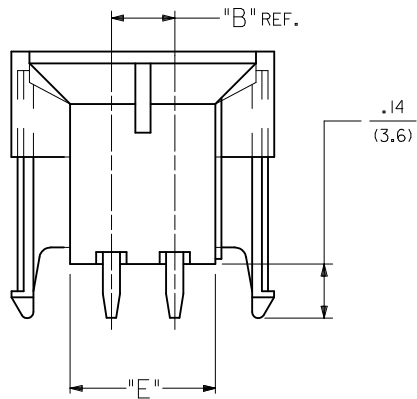
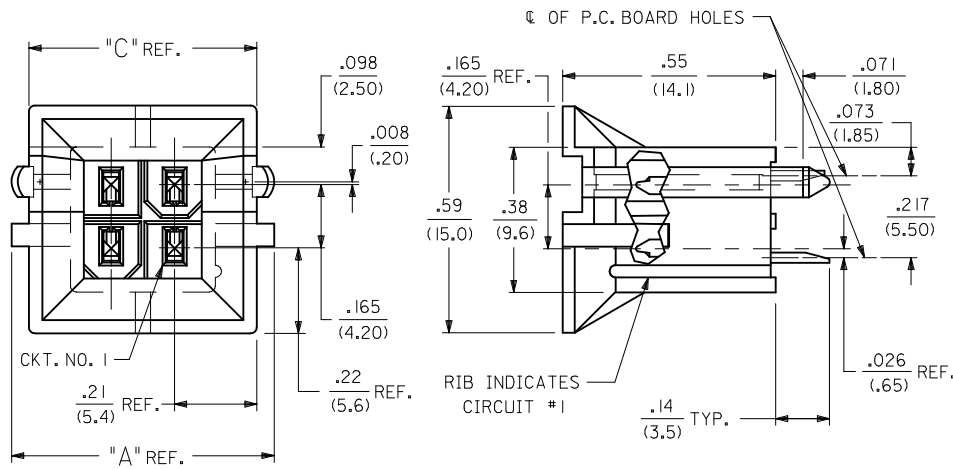

RECOMMENDED HOLE LAYOUT FOR .070/(1.78) MAX. THICK P.C. BOARD

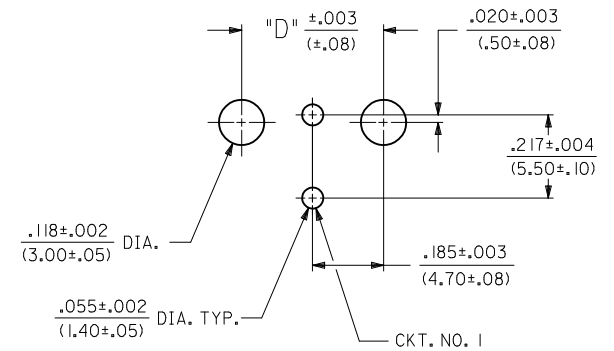
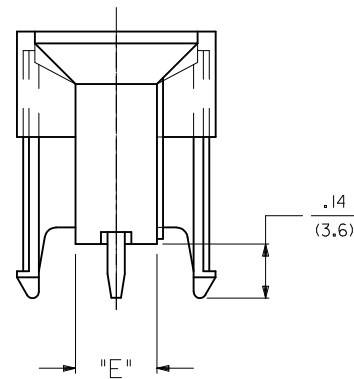
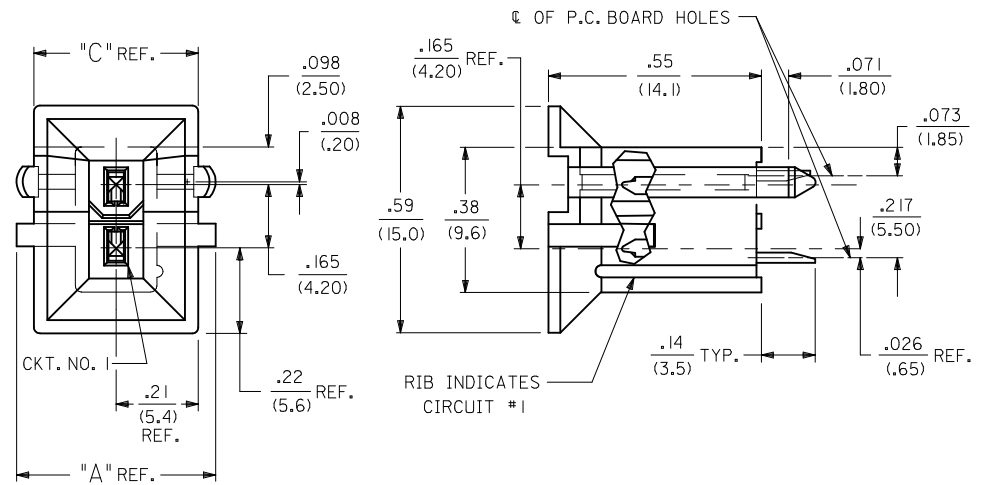





RECOMMENDED HOLE LAYOUT FOR .070/(1.78) MAX. THICK P.C. BOARD

SEE SHEET 1 EC NO: UCP2010-1524 DRWN: JAGUILAR CHKD: J.BELL APPR: FSMITH 2011/01/11 2011/01/11 2011/02/11	QUALITY SYMBOLS	GENERAL TOLERANCES (UNLESS SPECIFIED)	DIMENSION STYLE	SCALE	DESIGN UNITS	THIRD ANGLE PROJECTION															
	$\nabla = 0$ $\nabla = 0$ $\nabla = 0$	<table border="1"> <thead> <tr> <th></th> <th>mm</th> <th>INCH</th> </tr> </thead> <tbody> <tr> <td>4 PLACES</td> <td>± ---</td> <td>± ---</td> </tr> <tr> <td>3 PLACES</td> <td>± ---</td> <td>± .010</td> </tr> <tr> <td>2 PLACES</td> <td>± 0.25</td> <td>± .015</td> </tr> <tr> <td>1 PLACE</td> <td>± 0.38</td> <td>± ---</td> </tr> </tbody> </table>		mm	INCH	4 PLACES	± ---	± ---	3 PLACES	± ---	± .010	2 PLACES	± 0.25	± .015	1 PLACE	± 0.38	± ---	IN/MM	1:1	METRIC	
		mm	INCH																		
	4 PLACES	± ---	± ---																		
3 PLACES	± ---	± .010																			
2 PLACES	± 0.25	± .015																			
1 PLACE	± 0.38	± ---																			
DRAWN BY: GEP CHECKED BY: R.JF APPROVED BY: FSMITH DATE: 1989/04/06 DATE: 1989/04/06 DATE: 2011/02/11	ANGULAR ± 5° DRAFT WHERE APPLICABLE MUST REMAIN WITHIN DIMENSIONS	DRAWN BY: GEP CHECKED BY: R.JF APPROVED BY: FSMITH DATE: 1989/04/06 DATE: 1989/04/06 DATE: 2011/02/11	TITLE: MINI-FIT B.M.I. VERTICAL HEADER ASSY WITH DRAIN HOLE OPTION MOLEX INCORPORATED	DOCUMENT NO.: SDA-42440-**** SHEET NO.: 2 OF 5																	
Q2	REV	SIZE	THIS DRAWING CONTAINS INFORMATION THAT IS PROPRIETARY TO MOLEX INCORPORATED AND SHOULD NOT BE USED WITHOUT WRITTEN PERMISSION																		

NOTES:

- 1) MATERIAL:
 - HOUSING MATERIAL AND OPTIONS:
 - 1 = NYLON 6/6, UL 94V-2, COLOR: NATURAL, WITHOUT DRAIN HOLES
 - 2 = NYLON 6/6, UL 94V-0, COLOR: NATURAL, WITHOUT DRAIN HOLES
 - 3 = NYLON 6/6, UL 94V-2, COLOR: NATURAL, WITH DRAIN HOLES
 - 4 = NYLON 6/6, UL 94V-0, COLOR: NATURAL, WITH DRAIN HOLES
 - TERMINALS: BRASS
- 2) TERMINAL PLATING:
 - S = .000100/(0.00254) MIN. BRIGHT TIN OVER .000050/(0.00127) MIN. NICKEL
 - GS = .000030/(0.00076) MIN. SELECT GOLD AND .000100/(0.00254) MIN. SELECT MATTE TIN OVER .000050/(0.00127) MIN. NICKEL OVERALL
 - GS3 = .000050/(0.00127) MIN. SELECT GOLD AND .000100/(0.00254) MIN. SELECT MATTE TIN OVER .000050/(0.00127) MIN. NICKEL OVERALL
- 3) PRODUCT SPECIFICATION AND PROCESSING PARAMETERS: PS-5556-002
- 4) PACKAGING: SEE CHARTS
- 5) 6-24 CIRCUIT PARTS MATE WITH MINI-FIT JR. RECEPTACLES #5557 AND HEADERS #42385 AND #42474; 2 AND 4 CIRCUIT PARTS MATE WITH 42385 AND 42474 HEADERS ONLY.
- 6) PART ALLOWS FOR UP TO .100/(2.54) MISALIGNMENT WITH MATING RECEPTACLE IN ANY DIRECTION. SEE MATING CONNECTOR DRAWINGS FOR SPECIFIC ALLOWANCES.
- 7) CONNECTOR IS NOT DESIGNED FOR CURRENT SHARING.
- 8) CONNECTOR ASSEMBLIES ARE NOT BE MATED OR UNMATED WHILE CIRCUITS ARE LIVE.
- 9) OPTIONAL RIBS MAY BE FOUND ON PARTS MANUFACTURED AFTER 08/11/1997. RIB LOCATION IS DETERMINED BY MOLD DESIGN FOR MANUFACTURING EASE AND THE LOCATION DOES NOT AFFECT PART FUNCTION OR PERFORMANCE. LOCATION OF RIBS MAY VARY ON PARTS WITHIN MAUFACTURING LOT OR SHIPMENT. THIS DRAWING SHOWS TYPICAL RIB LOCATIONS.
- 10) PARTS MANUFACTURED AFTER 8/15/1997 MAY HAVE REVISED LOCK PEG.
- 11) PART CONFORMS TO CLASS "B" REQUIREMENTS OF COSMETIC SPECIFICATION" PS-45499-002.
- 12)  12 CIRCUIT PARTS HAVE A SLOT BETWEEN CIRCUITS 7 AND 8.

SEE SHEET 1 EC NO: UCP2010-1524 DRWN: JAGUILAR CHKD: J.BELL APPR: FSMITH	2011/01/11 2011/01/11 2011/02/11	DESCRIPTION REV	QUALITY SYMBOLS	GENERAL TOLERANCES (UNLESS SPECIFIED)	DIMENSION STYLE	SCALE	DESIGN UNITS	THIRD ANGLE PROJECTION
			 = 0	mm INCH	IN/MM	1:1	METRIC	MINI-FIT B.M.I. VERTICAL HEADER ASSY WITH DRAIN HOLE OPTION  MOLEX INCORPORATED
			 = 0	4 PLACES ± --- ± ---	DRAWN BY DATE	GEP 1989/04/06 CHECKED BY DATE RJF 1989/04/06 APPROVED BY DATE FSMITH 2011/02/11		
			 = 0	3 PLACES ± --- ± .010	2 PLACES ± 0.25 ± .015			
	1 PLACE ± 0.38 ± ---	ANGULAR ± 5 °						
Q2			DRAFT WHERE APPLICABLE MUST REMAIN WITHIN DIMENSIONS	SEE CHART	MATERIAL NO.	DOCUMENT NO.	SHEET NO.	
						SDA-42440-****	3 OF 5	
				THIS DRAWING CONTAINS INFORMATION THAT IS PROPRIETARY TO MOLEX INCORPORATED AND SHOULD NOT BE USED WITHOUT WRITTEN PERMISSION				

13	12	11	10	9	8	7	6	5	4	3	2	1			
PLATING: TIN (SEE NOTE 2 OPTION 'S')				PLATING: TIN (SEE NOTE 2 OPTION 'S')				PLATING: 30 M.I. SELECT GOLD (SEE NOTE 2 OPTION 'GS')				PLATING: 30 M.I. SELECT GOLD (SEE NOTE 2 OPTION 'GS')			
DRAINS: WITHOUT DRAIN HOLES				DRAINS: WITHOUT DRAIN HOLES				DRAINS: WITHOUT DRAIN HOLES				DRAINS: WITHOUT DRAIN HOLES			
PEGS: WITH PEGS				PEGS: WITH PEGS				PEGS: WITH PEGS				PEGS: WITH PEGS			
MAT'L: 94V-2 [NATURAL]				MAT'L: 94V-0 [NATURAL]				MAT'L: 94V-2 [NATURAL]				MAT'L: 94V-0 [NATURAL]			
PACKAGING: TRAY PER PK-42440-001				PACKAGING: TRAY PER PK-42440-001				PACKAGING: TRAY PER PK-42440-001				PACKAGING: TRAY PER PK-42440-001			
PART NO.	ENG NO.		CKTS	PART NO.	ENG NO.		CKTS	PART NO.	ENG NO.		CKTS	PART NO.	ENG NO.		CKTS
NO EDP	A-42440-021I	-	2	NO EDP	A-42440-022I	-	2	NO EDP	A-42440-0212	-	2	NO EDP	A-42440-0222	-	2
15-24-6041	A-42440-041I	-	4	15-24-6042	A-42440-042I	-	4	15-28-6041	A-42440-0412	-	4	15-28-6042	A-42440-0422	-	4
15-24-6061	A-42440-061I	-	6	NO EDP	A-42440-062I	-	6	15-28-6061	A-42440-0612	-	6	NO EDP	A-42440-0622	-	6
NO EDP	A-42440-081I	-	8	NO EDP	A-42440-082I	-	8	NO EDP	A-42440-0812	-	8	NO EDP	A-42440-0822	-	8
15-24-6101	A-42440-101I	-	10	15-24-6102	A-42440-102I	-	10	15-28-6101	A-42440-1012	-	10	15-28-6102	A-42440-1022	-	10
15-24-6121	A-42440-121I	-	12	15-24-6122	A-42440-122I	-	12	15-28-6121	A-42440-1212	-	12	15-28-6122	A-42440-1222	-	12
15-24-6141	A-42440-141I	-	14	15-24-6142	A-42440-142I	-	14	15-28-6141	A-42440-1412	-	14	15-28-6142	A-42440-1422	-	14
15-24-6161	A-42440-161I	-	16	15-24-6162	A-42440-162I	-	16	15-28-6161	A-42440-1612	-	16	NO EDP	A-42440-1622	-	16
15-24-6181	A-42440-181I	-	18	15-24-6182	A-42440-182I	-	18	15-28-6181	A-42440-1812	-	18	15-28-6182	A-42440-1822	-	18
NO EDP	A-42440-201I	-	20	NO EDP	A-42440-202I	-	20	NO EDP	A-42440-2012	-	20	NO EDP	A-42440-2022	-	20
NO EDP	A-42440-221I	-	22	NO EDP	A-42440-222I	-	22	NO EDP	A-42440-2212	-	22	NO EDP	A-42440-2222	-	22
15-24-6241	A-42440-241I	-	24	15-24-6242	A-42440-242I	-	24	15-28-6241	A-42440-2412	-	24	15-28-6242	A-42440-2422	-	24
	-	-			-	-			-	-			-	-	
	-	-			-	-			-	-			-	-	

PLATING: TIN (SEE NOTE 2 OPTION 'S')				PLATING: TIN (SEE NOTE 2 OPTION 'S')				PLATING: 30 M.I. SELECT GOLD (SEE NOTE 2 OPTION 'GS')				PLATING: 30 M.I. SELECT GOLD (SEE NOTE 2 OPTION 'GS')			
DRAINS: WITH DRAIN HOLES				DRAINS: WITH DRAIN HOLES				DRAINS: WITH DRAIN HOLES				DRAINS: WITH DRAIN HOLES			
PEGS: WITH PEGS				PEGS: WITH PEGS				PEGS: WITH PEGS				PEGS: WITH PEGS			
MAT'L: 94V-2 [NATURAL]				MAT'L: 94V-0 [NATURAL]				MAT'L: 94V-2 [NATURAL]				MAT'L: 94V-0 [NATURAL]			
PACKAGING: TRAY PER PK-42440-001				PACKAGING: TRAY PER PK-42440-001				PACKAGING: TRAY PER PK-42440-001				PACKAGING: TRAY PER PK-42440-001			
PART NO.	ENG NO.		CKTS	PART NO.	ENG NO.		CKTS	PART NO.	ENG NO.		CKTS	PART NO.	ENG NO.		CKTS
NO EDP	A-42440-023I	-	2	NO EDP	A-42440-024I	-	2	NO EDP	A-42440-0232	-	2	NO EDP	A-42440-0242	-	2
15-24-6046	A-42440-043I	-	4	15-24-6047	A-42440-044I	-	4	15-28-6046	A-42440-0432	-	4	15-28-6047	A-42440-0442	-	4
NO EDP	A-42440-063I	-	6	NO EDP	A-42440-064I	-	6	NO EDP	A-42440-0632	-	6	NO EDP	A-42440-0642	-	6
NO EDP	A-42440-083I	-	8	NO EDP	A-42440-084I	-	8	NO EDP	A-42440-0832	-	8	NO EDP	A-42440-0842	-	8
15-24-6106	A-42440-103I	-	10	15-24-6107	A-42440-104I	-	10	15-28-6106	A-42440-1032	-	10	15-28-6107	A-42440-1042	-	10
NO EDP	A-42440-123I	-	12	NO EDP	A-42440-124I	-	12	NO EDP	A-42440-1232	-	12	NO EDP	A-42440-1242	-	12
15-24-6146	A-42440-143I	-	14	15-24-6147	A-42440-144I	-	14	15-28-6146	A-42440-1432	-	14	15-28-6147	A-42440-1442	-	14
NO EDP	A-42440-163I	-	16	NO EDP	A-42440-164I	-	16	NO EDP	A-42440-1632	-	16	NO EDP	A-42440-1642	-	16
15-24-6186	A-42440-183I	-	18	15-24-6187	A-42440-184I	-	18	15-28-6186	A-42440-1832	-	18	15-28-6187	A-42440-1842	-	18
NO EDP	A-42440-203I	-	20	NO EDP	A-42440-204I	-	20	NO EDP	A-42440-2032	-	20	NO EDP	A-42440-2042	-	20
NO EDP	A-42440-223I	-	22	NO EDP	A-42440-224I	-	22	NO EDP	A-42440-2232	-	22	NO EDP	A-42440-2242	-	22
15-24-6246	A-42440-243I	-	24	15-24-6247	A-42440-244I	-	24	15-28-6246	A-42440-2432	-	24	15-28-6247	A-42440-2442	-	24
	-	-			-	-			-	-			-	-	
	-	-			-	-			-	-			-	-	

SEE SHEET 1 EC NO: UCP2010-1524 DRWN: JAGUILAR 2011/01/11 CHKD: JEBEL 2011/01/11 APPR: FSMITH 2011/02/11	QUALITY SYMBOLS ∇=0 ∇=0 ∇=0	GENERAL TOLERANCES (UNLESS SPECIFIED)		DIMENSION STYLE IN/MM		SCALE 1:1	DESIGN UNITS METRIC	THIRD ANGLE PROJECTION		
		4 PLACES ± --- ± ---		DRAWN BY GEP		DATE 1989/04/06		MINI-FIT B.M.I. VERTICAL HEADER ASSY WITH DRAIN HOLE OPTION		
		3 PLACES ± --- ± .010		CHECKED BY RJF		DATE 1989/04/06				
		2 PLACES ± 0.25 ± .015		APPROVED BY FSMITH		DATE 2011/02/11		MOLEX INCORPORATED		
1 PLACE ± 0.38 ± ---		ANGULAR ± 5 °		MATERIAL NO.		DOCUMENT NO.				
DRAFT WHERE APPLICABLE MUST REMAIN WITHIN DIMENSIONS				SEE CHART		SDA-42440-****		4 OF 5		
THIS DRAWING CONTAINS INFORMATION THAT IS PROPRIETARY TO MOLEX INCORPORATED AND SHOULD NOT BE USED WITHOUT WRITTEN PERMISSION										

	13		12		11		10		9		8		7		6		5		4		3		2		1
J	PLATING:	50 M.I. SELECT GOLD (SEE NOTE 2 OPTION *GS3*)				PLATING:	50 M.I. SELECT GOLD (SEE NOTE 2 OPTION *GS3*)				PLATING:					PLATING:									
	DRAINS:	WITHOUT DRAIN HOLES				DRAINS:	WITHOUT DRAIN HOLES				DRAINS:					DRAINS:									
	PEGS:	WITH PEGS				PEGS:	WITH PEGS				PEGS:					PEGS:									
	MAT'L:	94V-2 [NATURAL]				MAT'L:	94V-0 [NATURAL]				MAT'L:					MAT'L:									
	PACKAGING:	TRAY PER PK-42440-001				PACKAGING:	TRAY PER PK-42440-001				PACKAGING:					PACKAGING:									
I	PART NO.	ENG NO.			CKTS	PART NO.	ENG NO.			CKTS	PART NO.	ENG NO.			CKTS	PART NO.	ENG NO.			CKTS					
	NO EDP	A-42440-0213	-		2	NO EDP	A-42440-0223	-		2	NO EDP	-	-		2	NO EDP	-	-		2					
	NO EDP	A-42440-0413	-		4	NO EDP	A-42440-0423	-		4	NO EDP	-	-		4	NO EDP	-	-		4					
	NO EDP	A-42440-0613	-		6	NO EDP	A-42440-0623	-		6	NO EDP	-	-		6	NO EDP	-	-		6					
	NO EDP	A-42440-0813	-		8	NO EDP	A-42440-0823	-		8	NO EDP	-	-		8	NO EDP	-	-		8					
	NO EDP	A-42440-1013	-		10	NO EDP	A-42440-1023	-		10	NO EDP	-	-		10	NO EDP	-	-		10					
	NO EDP	A-42440-1213	-		12	NO EDP	A-42440-1223	-		12	NO EDP	-	-		12	NO EDP	-	-		12					
	NO EDP	A-42440-1413	-		14	NO EDP	A-42440-1423	-		14	NO EDP	-	-		14	NO EDP	-	-		14					
	NO EDP	A-42440-1613	-		16	NO EDP	A-42440-1623	-		16	NO EDP	-	-		16	NO EDP	-	-		16					
H	NO EDP	A-42440-1813	-		18	NO EDP	A-42440-1823	-		18	NO EDP	-	-		18	NO EDP	-	-		18					
	NO EDP	A-42440-2013	-		20	NO EDP	A-42440-2023	-		20	NO EDP	-	-		20	NO EDP	-	-		20					
	NO EDP	A-42440-2213	-		22	NO EDP	A-42440-2223	-		22	NO EDP	-	-		22	NO EDP	-	-		22					
	NO EDP	A-42440-2413	-		24	NO EDP	A-42440-2423	-		24	NO EDP	-	-		24	NO EDP	-	-		24					
		-	-				-	-				-	-				-	-							
		-	-				-	-				-	-				-	-							



SEE SHEET 1 EC NO: UCP2010-1524 DRWN: JAGUILAR CHKD: J.BELL APPR: FSMITH	2011/01/11 2011/01/11 2011/02/11	DESCRIPTION REV	QUALITY SYMBOLS	GENERAL TOLERANCES (UNLESS SPECIFIED)	DIMENSION STYLE	SCALE	DESIGN UNITS	THIRD ANGLE PROJECTION
			▽=0	mm INCH	IN/MM	1:1	METRIC	MINI-FIT B.M.I. VERTICAL HEADER ASSY WITH DRAIN HOLE OPTION MOLEX INCORPORATED
			▽=0	4 PLACES ± --- ± ---	DRAWN BY DATE	GEP 1989/04/06 R.J.F. 1989/04/06 FSMITH 2011/02/11		
			▽=0	3 PLACES ± --- ±.010	CHECKED BY DATE			
	2 PLACES ± 0.25 ±.015	APPROVED BY DATE						
	1 PLACE ± 0.38 ± ---	ANGULAR ± 5 °	MATERIAL NO.	DOCUMENT NO.	SHEET NO.			
Q2			DRAFT WHERE APPLICABLE MUST REMAIN WITHIN DIMENSIONS	SEE CHART	SDA-42440-****	5 OF 5		
				SIZE	THIS DRAWING CONTAINS INFORMATION THAT IS PROPRIETARY TO MOLEX INCORPORATED AND SHOULD NOT BE USED WITHOUT WRITTEN PERMISSION			

	12		11		10		9		8		7		6		5		4		3		2		1
--	----	--	----	--	----	--	---	--	---	--	---	--	---	--	---	--	---	--	---	--	---	--	---

X-ON Electronics

Largest Supplier of Electrical and Electronic Components

Click to view similar products for [Headers & Wire Housings](#) category:

Click to view products by [Molex](#) manufacturer:

Other Similar products are found below :

[95000-104TRLF](#) [10135584-644402LF](#) [DF62W-EP2022PCA](#) [95000-106TRLF](#) [DF62W-2022SCA](#) [DF62W-EP2022PC](#) [2203348](#) [DF62W-2022SC](#) [1084018](#) [1029039](#) [1084017](#) [802-10-012-10-002000](#) [1112640](#) [1112639](#) [891-007-9SS-BST1T](#) [000-34000](#) [0008550134](#) [0009482033](#) [0009507031](#) [57102-F02-18ULF](#) [57102-S06-03LF](#) [57202-S52-04LF](#) [PCN6-15S-2.5E](#) [0039019024](#) [58102-G61-06LF](#) [582553-1](#) [0009485154](#) [0009508121](#) [0022285053](#) [0050291907](#) [018731A](#) [LY20-4P-DT1-P1E-BR](#) [02.125.8002.8](#) [60101931](#) [60598-1 \(Cut Strip\)](#) [M1625-3R/100](#) [61062-3](#) [61082-181009](#) [CSU011177004](#) [636-1427](#) [638009-1](#) [641938-9](#) [641991-4](#) [644168-1](#) [644827-2](#) [647662-1](#) [65039-019ELF](#) [65692-001LF](#) [65781-018](#) [65781-047](#)