

SYMBOL DEFINITION		TOTAL NO OF INSPECTIONS REQUIRED		MISSING SYMBOLS	
A DIMENSION WITHOUT AN INSPECTION REPORT SYMBOL DOES NOT REQUIRE INSPECTION. IT MAY BE CONTROLLED ON THE INDIVIDUAL COMPONENT DRAWING.			16		
		LAST NO. USED	13		

DATE	STG	REV	N/P	ZONE	REVISION HISTORY	AUTH	DR	APV/D
31MY02	R	04	-	-	ALL PARTS - CLEARED REV COLUMN & REVISED MAT'L SPECS; 15304722-25 - UPDATED PDM ATTRIBUTES	222820	HAM	HAM/DLB
30JL02	R	05	-	-	ALL PARTS - UPDATED PDM ATTRIBUTES	226419	MRF	JVM/TTP
24JA03	R	06	-	-	ADVANCED REVISION LEVEL	235918	LMB	LMB/TV
23JA04	R	07	-	-	ADVANCED REVISION LEVEL	251141	LMB	LMB/LN
04CC04	R	08	-	-	ALL PARTS - ADDED STAMP DIE I.D.	259308	JPB	JVM/MKM
13CC04	R	09	-	-	ADVANCED REVISION LEVEL	259807	QPS	AUG/MY
10MR06	R	10	-	-	12191137, 15304722-25 - UPDATED PDM ATTRIBUTES	276500	JTV	AUG/JS
30JL07	R	11	-	-	12191136 - UPDATED PDM ATTRIBUTES	401962	JBD	AUG/EJH
25SE08	R	12	-	-	13734674 - RELEASED	406226	VMR	JHP/VMR
29OC08	R	13	-	-	ALL PARTS - UPDATED MAT'L CALLOUT	406598	HAD	VMR/HAD
08DE08	R	14	-	-	ALL PARTS - UPDATED PDM ATTRIBUTES	406985	HAD	RHG/HAD
22JA09	R	15	-	-	12191138 - CREATED MATH MODEL ALL PARTS - UPDATED VIEWS	407063	LGB	JVM/LGB
26FE09	R	16	-	-	13737694 - WAS ON DRAWING 15304726 SHT 1	407452	JTZ	FKV/BER
08MR10	R	17	-	-	ALL PARTS - UPDATED PDM ATTRIBUTES	410150	JTZ	JTZ/VMR
13AU10	R	18	-	-	ALL PARTS - PSD WAS #6	411623	JRL	JRL/LHT
31AU10	R	19	-	-	ALL PARTS - ADDED PLATING NOTE, UPDATED MAT'L CALLOUT AND ADDED CONTACT AREA & CRIMP AREA COLUMNS ON CHART	411803	CBG	CBG/VMR
04OC10	R	20	-	-	ALL PARTS - UPDATED PLATING NOTES	412125	CBG	CBG/VMR
24FE11	R	21	-	-	ALL PARTS - UPDATED PDM ATTRIBUTES	413453	MAB	JVM/VMR
29JL11	R	22	-	-	ALL PARTS - ADDED PREFERRED MAT'L SIZE COLUMN AND ALTERNATIVE MAT'L SIZE COLUMN WAS MAT'L SIZE COLUMN	414986	VMR	VMR/VMR
18OC12	R	23	-	-	15304722, 15304725 - UPDATED PDM ATTRIBUTES	419971	JLP	JVM/DGL
15OC14	R	24	-	-	13737694 - REVISED NOTE 111 ABOUT "TARNISH INFO" IN PLATING TYPE NOTE	427926	ABH	JVM/JSM

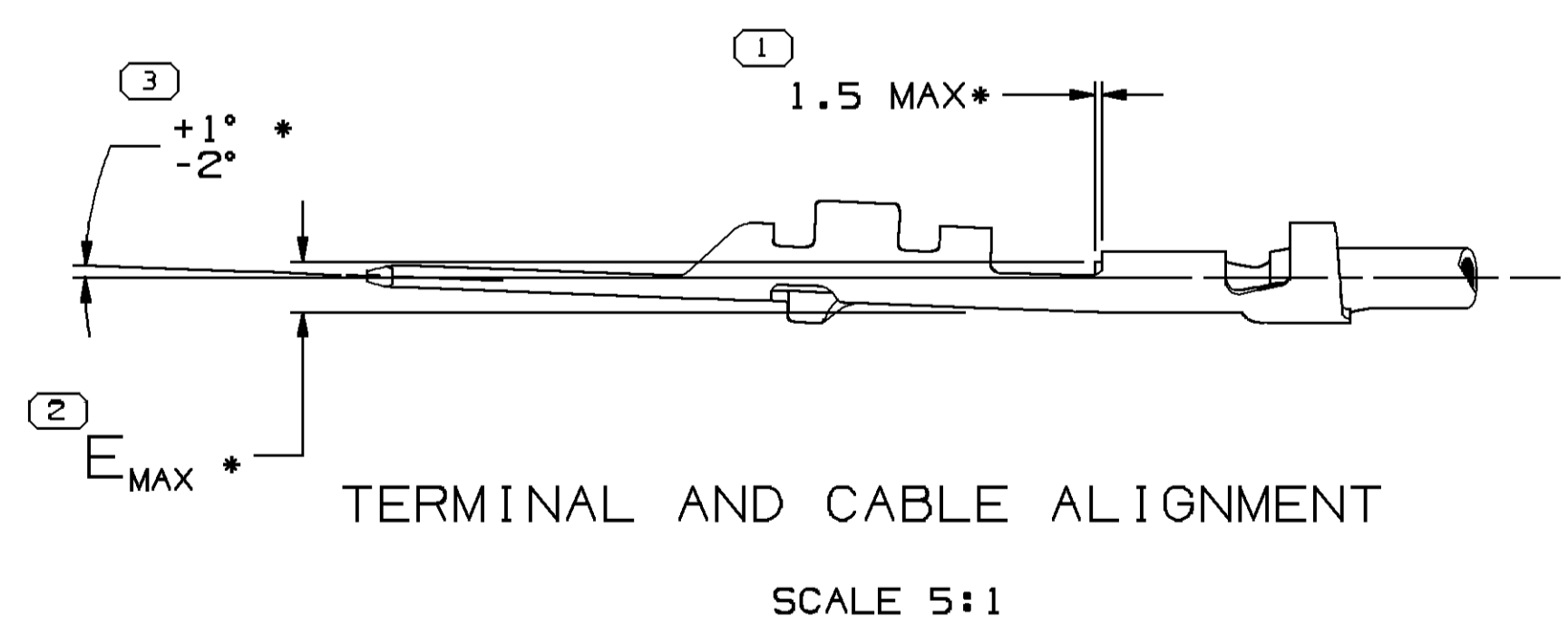
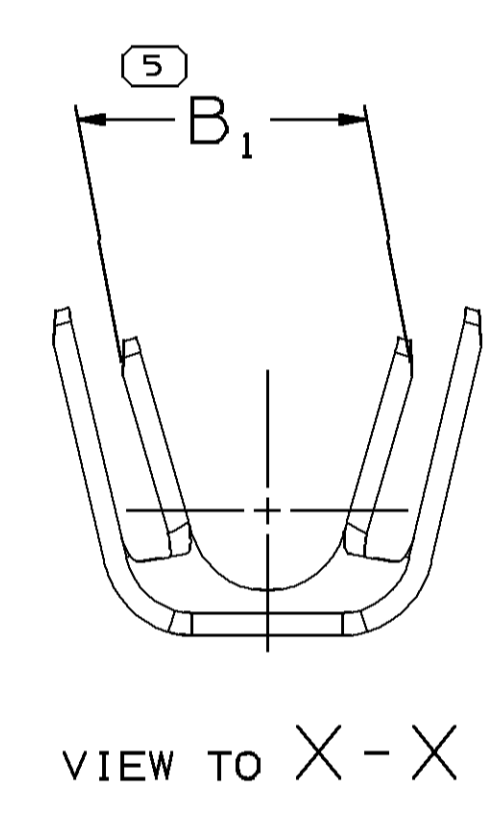
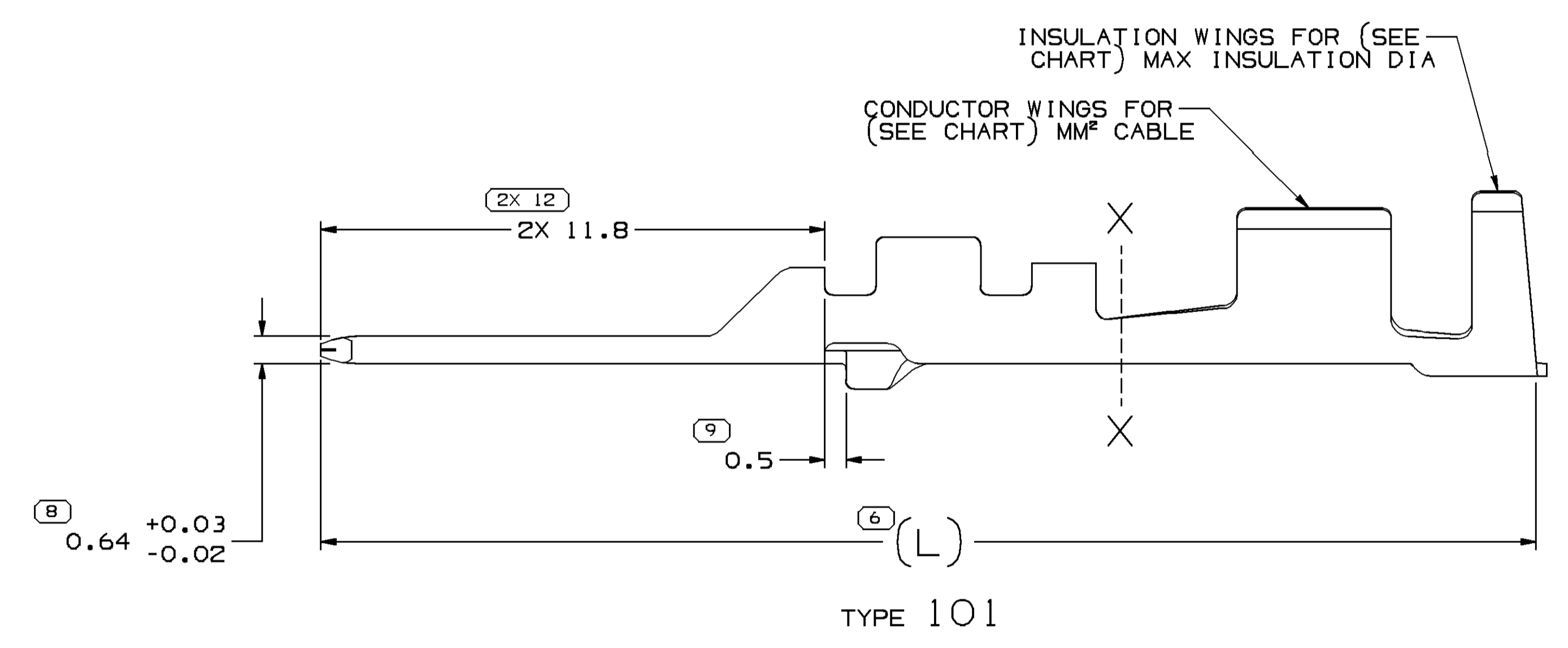
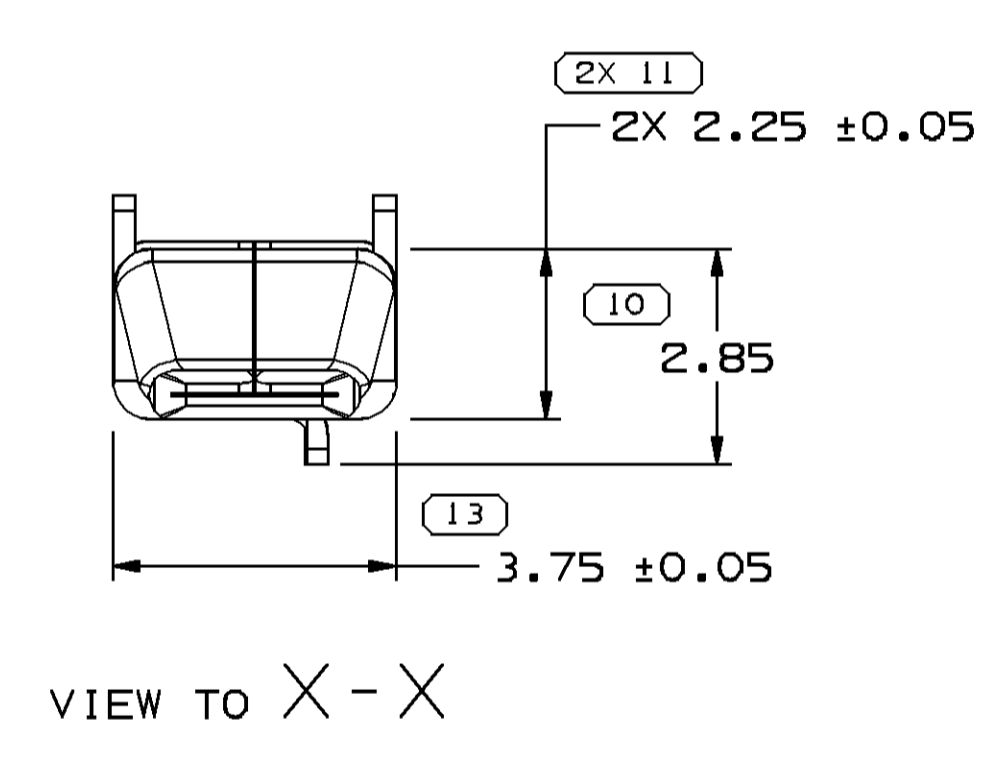
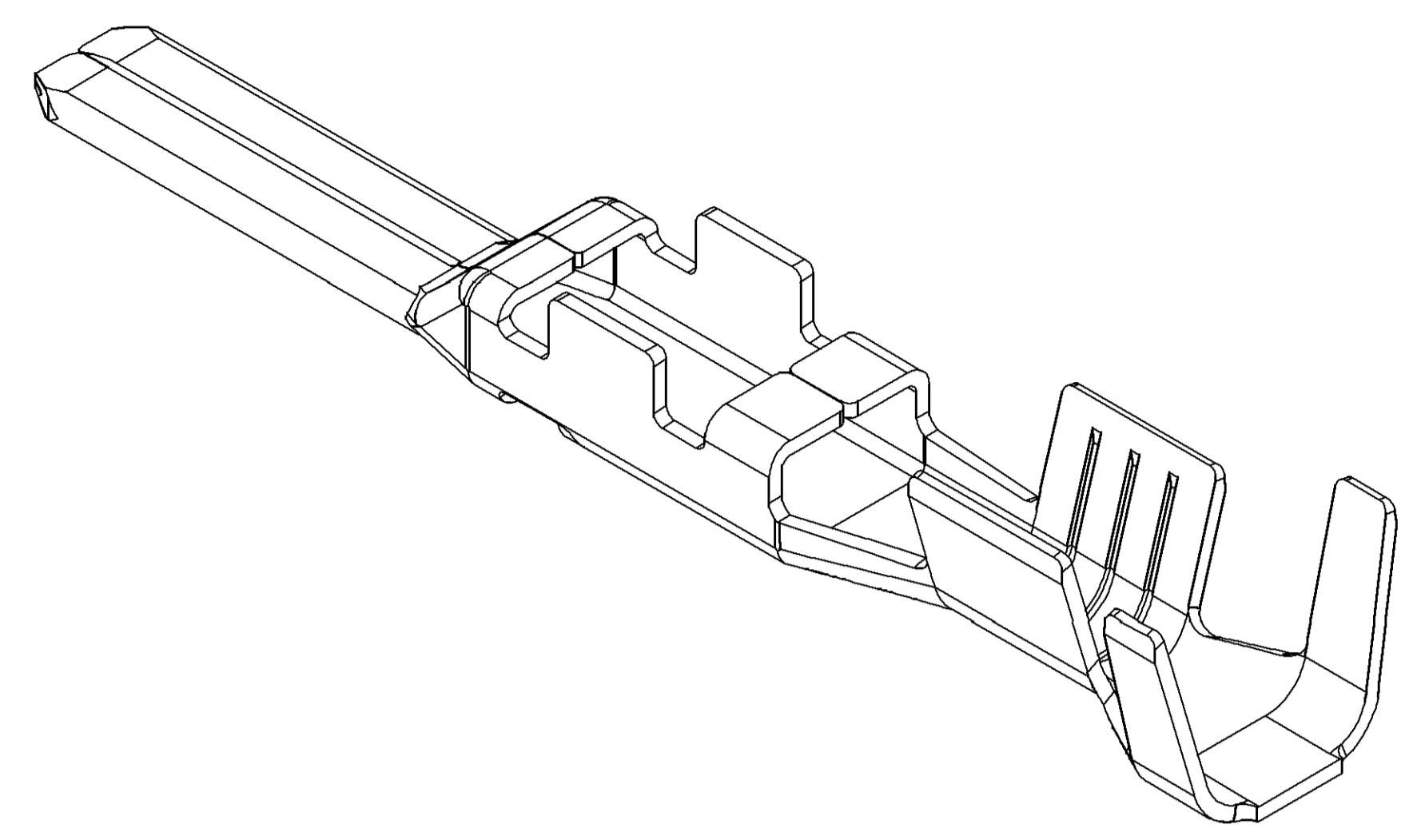
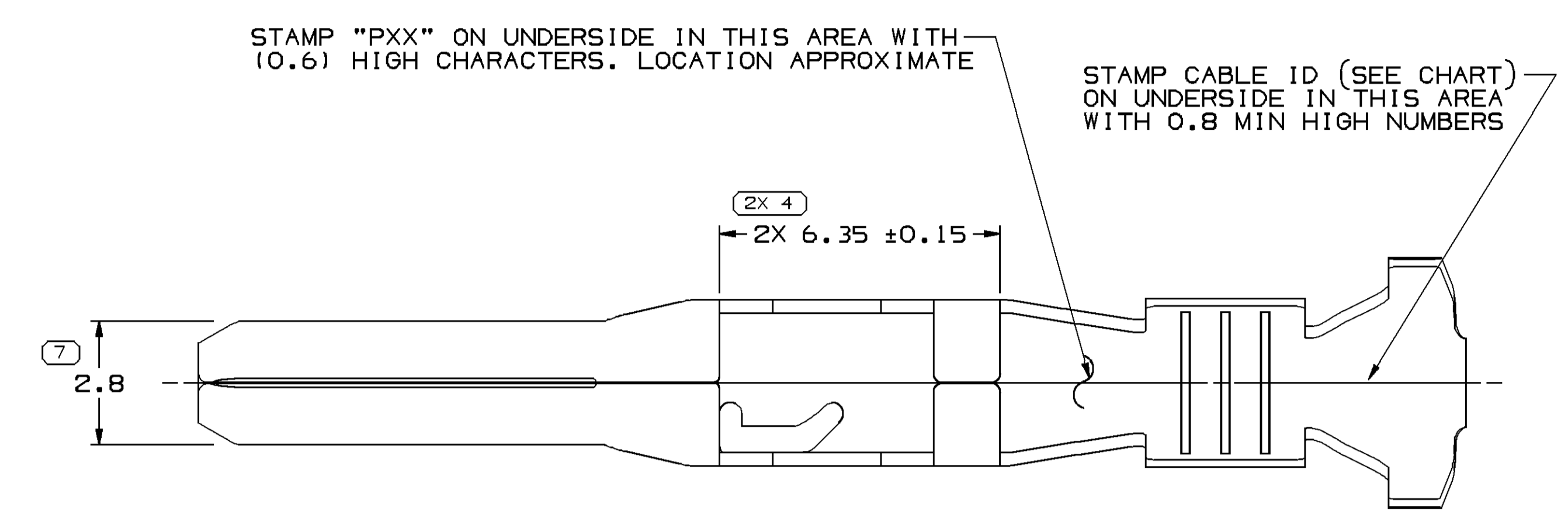

- NOTES
- UNLESS OTHERWISE SPECIFIED AND/OR INDICATED:
 - DIMENSIONS ARE TO FACE OF VIEW SHOWN AND AUTOMATICALLY ROUNDED BY COMPUTER FOR INSPECTION (SEE MATH MODEL FOR PRECISE DIMENSIONS). FOR ALL OTHER DIMENSIONS NOT SHOWN BUT REQUIRED FOR TOOL BUILD, SEE MATH MODEL FOR PRECISE TOOL PATH DATA.
 - REFERENCE MATING COMPONENTS OR EQUIVALENT:
 - TERMINAL 15304710
 - * DENOTES DIMENSIONS MADE AT CUT-OFF AND CRIMP DIE
 - PLATING TYPE:
 - I. REFLOW TIN 1.9 - 3.3 MICROMETERS THICK WITH A COPPER UNDERPLATE 0.5 MICROMETER TO 1.0 MICROMETER THICK.
 - II. MATE TIN ELECTROPLATE 1.9 - 7.0 MICROMETERS THICK WITH A NICKEL UNDERPLATE 0.13 - 0.25 MICROMETERS THICK.
 - III. SILVER 3.5 - 6.0 MICROMETERS THICK OVER 0.13 - 0.25 MICROMETERS THICK NICKEL UNDERPLATE.
- FOR TERMINALS PACKAGED & STORED IN THE APPROVED MANNER, TARNISH ON SILVER PLATED SURFACES WILL NOT AFFECT THE PERFORMANCE OF THE PART.
- PLATING TYPE INFORMATION SHOWN ABOVE IS REFERENCE ONLY. PLATING REQUIREMENTS ARE CONTAINED IN APPLICABLE MATERIAL SPECIFICATION.

PART NO	REV	N/P	RESTRICTED USAGE	PREFERRED MAT'L SIZE PLATED	ALTERNATIVE MAT'L SIZE	MATERIAL DESCRIPTION	SIZE (MM²)	ID	DIA	TYPE	CONTACT AREA PLATING TYPE (SEE NOTE 4)	CRIMP AREA PLATING TYPE (SEE NOTE 4)
13737694	01	AH	RESTRICTED	0.3 X 35.75	0.3 X 36.12	A6 PLATED COPPER ALLOY	4 - 5	10	3.9 - 3.4	101	4.8	28.45
13734674	01	AH	-	0.3 X 35.75	0.3 X 36.12	COPPER ALLOY	0.22 - 0.13	25	1.1 - 0.81	102	1.8	28.3
15336260	B12	-	-	0.3 X 35.75	0.3 X 36.12	COPPER ALLOY	1.25 - 2.5	14	3 - 2.05	101	3.7	28.15
15317758	C12	-	-	0.3 X 35.75	0.3 X 36.12	COPPER ALLOY	0.35 - 0.5	21	1.1 - 1.3	101	2.1	28.15
12191139	E13	-	-	0.3 X 35.75	0.3 X 36.12	COPPER ALLOY	(2) - 0.8	21B	2.05 - 1.7	101	3.8	28.45
12191137	D13	-	-	0.3 X 35.75	0.3 X 36.12	COPPER ALLOY	(2) - 0.5	220	1.85 - 1.4	101	3.2	28.45
12191136	D12	-	-	0.3 X 35.75	0.3 X 36.12	COPPER ALLOY	(2) - 0.35	222	1.65 - 1.2	101	2.7	28.45
15304725	D16	-	RESTRICTED	0.3 X 35.75	0.3 X 36.12	COPPER ALLOY	4 - 5	10	3.9 - 3.4	101	4.8	28.45
15304724	D17	-	-	0.3 X 35.75	0.3 X 36.12	COPPER ALLOY	1.5 - 3	13	3.2 - 2.2	101	3.75	28.15
15304723	D17	-	-	0.3 X 35.75	0.3 X 36.12	COPPER ALLOY	0.75 - 1	17	2.25 - 1.7	101	2.65	28.15
15304722	D18	-	-	0.3 X 35.75	0.3 X 36.12	COPPER ALLOY	0.35 - 0.5	21	1.85 - 1.2	101	2.1	28.15

DELPHI
DELPHI PACKARD ELECTRICAL/ELECTRONIC ARCHITECTURE

WARREN, OH
COPYRIGHT 1996 DELPHI CORPORATION AND/OR ITS AFFILIATES. ALL RIGHTS RESERVED.

THIS DRAWING IS THE PROPERTY OF DELPHI CORPORATION AND CONTAINS DELPHI CONFIDENTIAL INFORMATION. THE REPRODUCTION, DISTRIBUTION AND UTILIZATION OF THIS DOCUMENT OR ITS CONTENTS OR DATA, AS WELL AS COMMUNICATION OF ANY CONTENT TO OTHERS, WITHOUT EXPRESS AUTHORIZATION, IS PROHIBITED.

DATE: 01-Dec-14 Time: 09:45

UNLESS OTHERWISE SPECIFIED
DIMENSIONS ENCLOSED IN () INDICATE REFERENCE DIMENSIONS AND NO TOLERANCE LIMITS ARE ESTABLISHED.

THIS DOCUMENT IS IN ACCORDANCE WITH ASME Y14.5M-1994 AS MODIFIED BY THE 2003 DIMENSIONING AND TOLERANCING ADDENDUM - 1997. ALL GEOMETRIC TOLERANCES AND RELATED DATUMS APPLY UNLESS RULE 4 (PROPER FORM) IS USED. MFG DOES NOT APPLY WHEN RELATIONSHIP BETWEEN FEATURES IS ESTABLISHED BY ORIENTATION OR LOCATION TOLERANCES. SEPARATE POSITION CALLOUTS MAY BE SAVED SEPARATELY. REVISEMENTS OF DIMENSIONS ARE IN MILLIMETERS.

13 PROCESS SENSITIVE DIMENSION

DIMENSIONAL RANGE (MM) CHART CD FROM TO 0 > 12

TOLERANCE UNLESS OTHERWISE SPECIFIED: ±0.1 ±0.2 ANGLE TOLERANCE ±2°

THIRD ANGLE DO NOT SCALE USE MATH DATA

DATE: 01-Dec-14

SCALE: 10:1

FRM NO: 1

SHEET NO: 1 OF 1

STG REV N/P: R 24 -

DRAWING NUMBER: 15304721

TAXI TERM M 0T 280