

SYMBOL DEFINITION		MISSING SYMBOLS	
A DIMENSION WITHOUT AN INSPECTION REPORT SYMBOL DOES NOT REQUIRE INSPECTION. IT MAY BE CONTROLLED ON THE INDIVIDUAL COMPONENT DRAWING.	TOTAL NO OF INSPECTIONS REQUIRED	NO MISSING SYMBOL NUMBER	6
	LAST NO. USED		6

DWG STATUS				REVISION HISTORY				AUTH		DR		APVD	
DATE	STG	REV	N/P	CHG	ZONE								
01JL04	R	01	-	-		15423276 - WAS SEPARATE DWG; 15497403 - RELEASED		255602	JTZ	JAA	RMF		
14DE04	R	02	-	-		ALL PARTS - REVISED "MAT'L RECYCLING CODE" & "DELPHI LOGO" NOTES		262417	ADK	ADK	RMF		
27SE06	R	03	-	-		ALL PARTS - REMOVED MATERIAL BETWEEN BOTTOM RAILS		284322	LLJ	LLJ	RMF		
30AP07	R	04	-	-		ALL PARTS - RELOCATED DIMENSION #4 TO OPPOSITE SIDE OF PART AND UPDATED PDM ATTRIBUTES		401204	6E	6E	MJD		

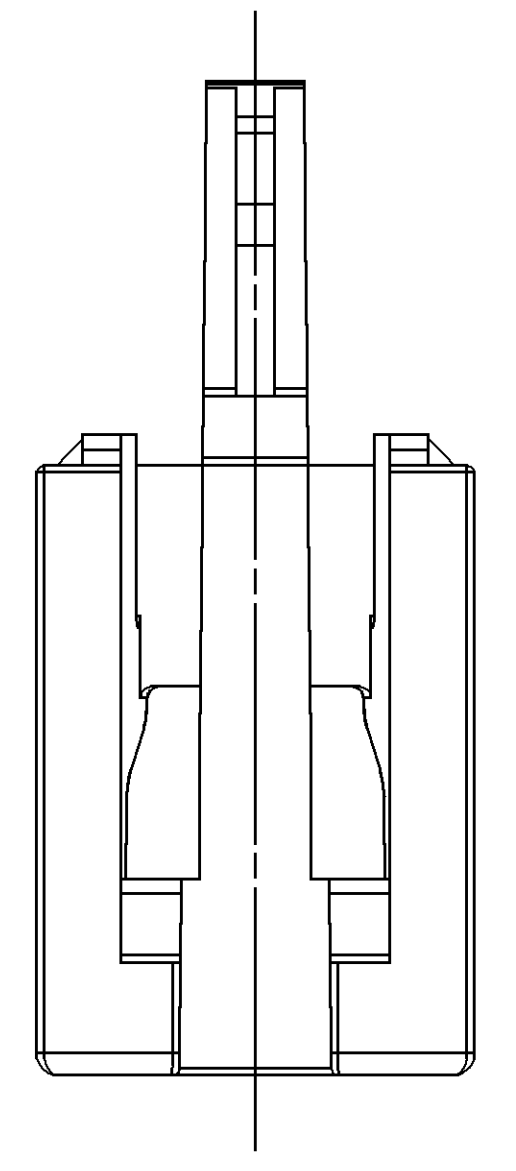
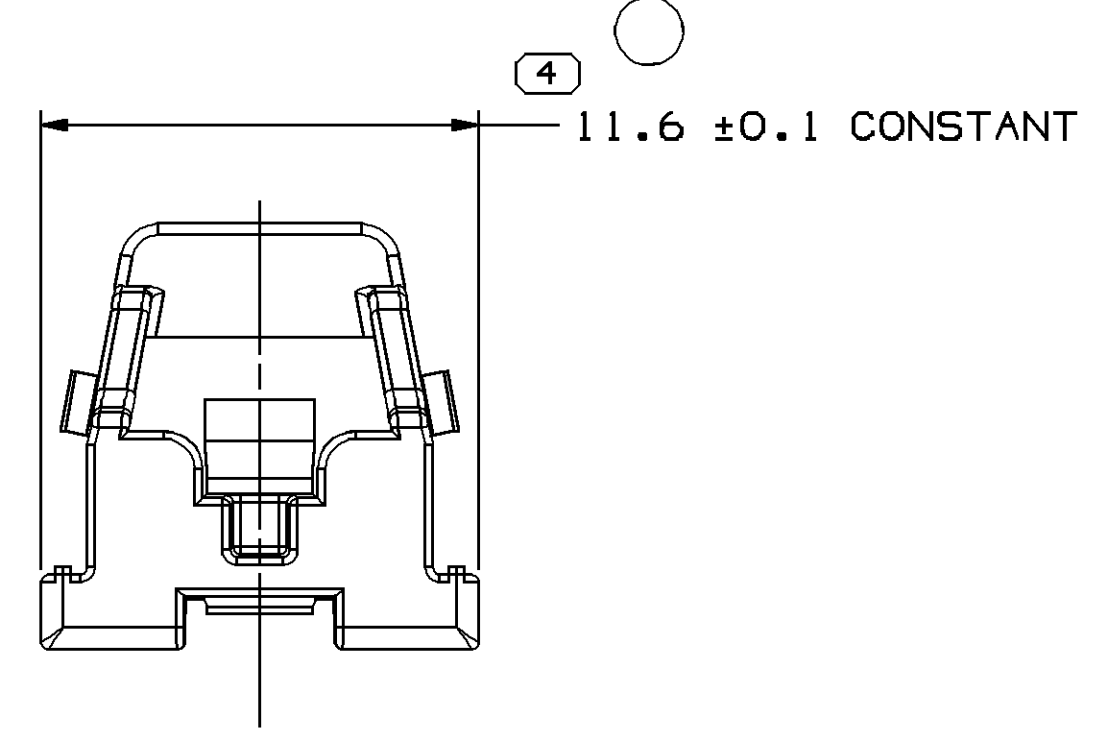
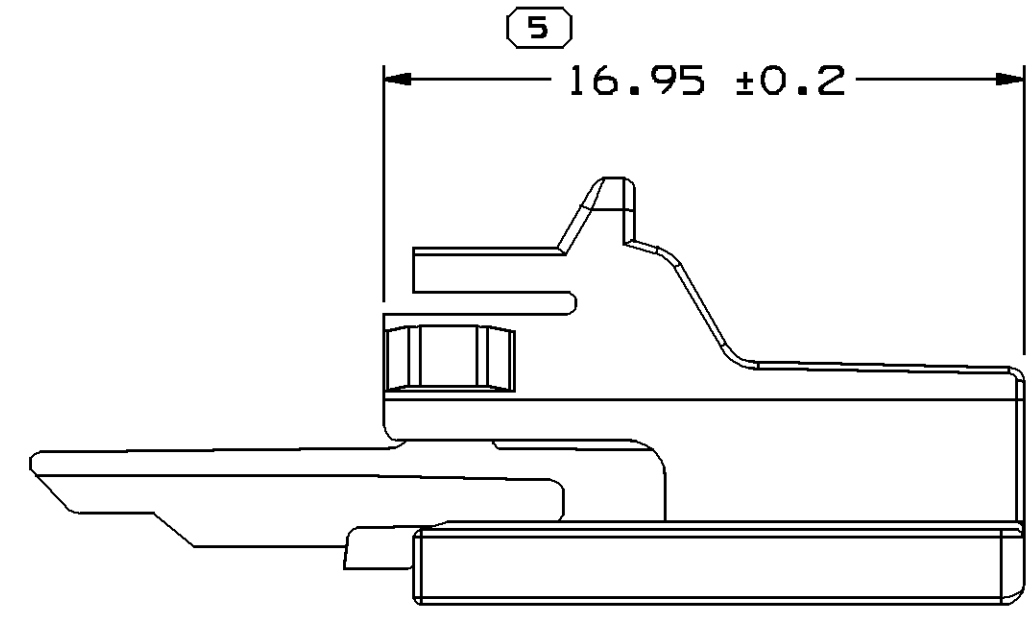
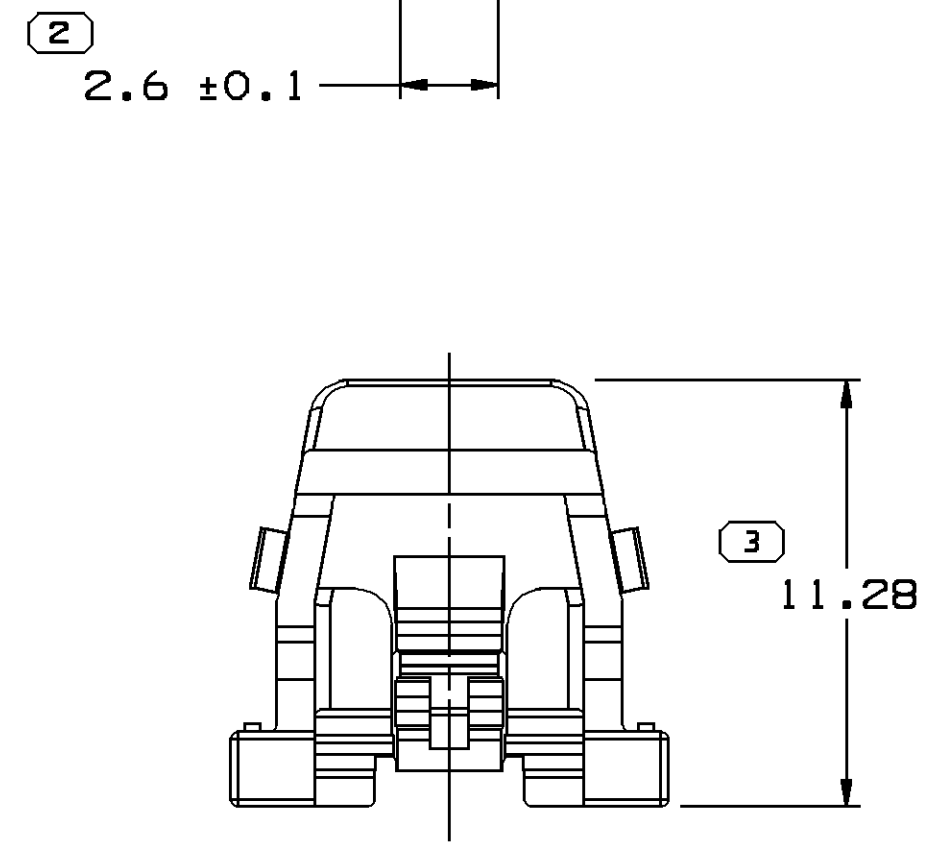
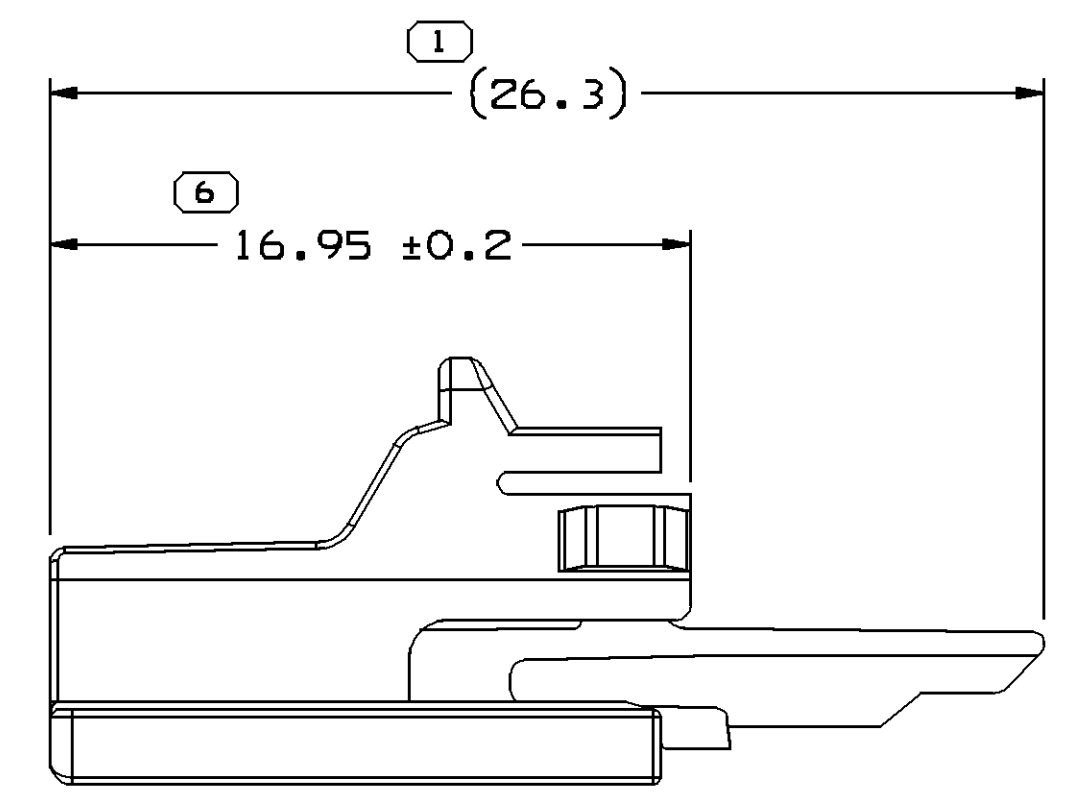
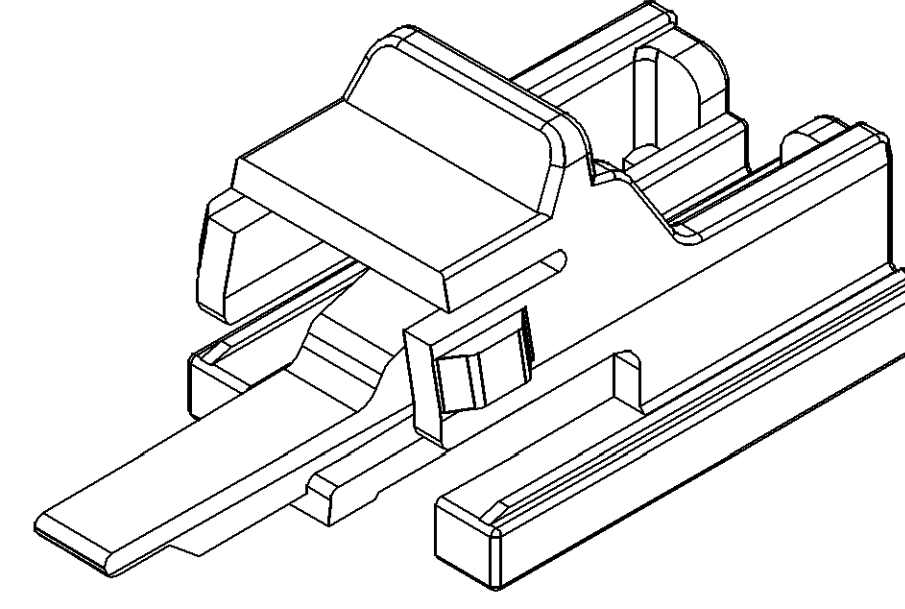
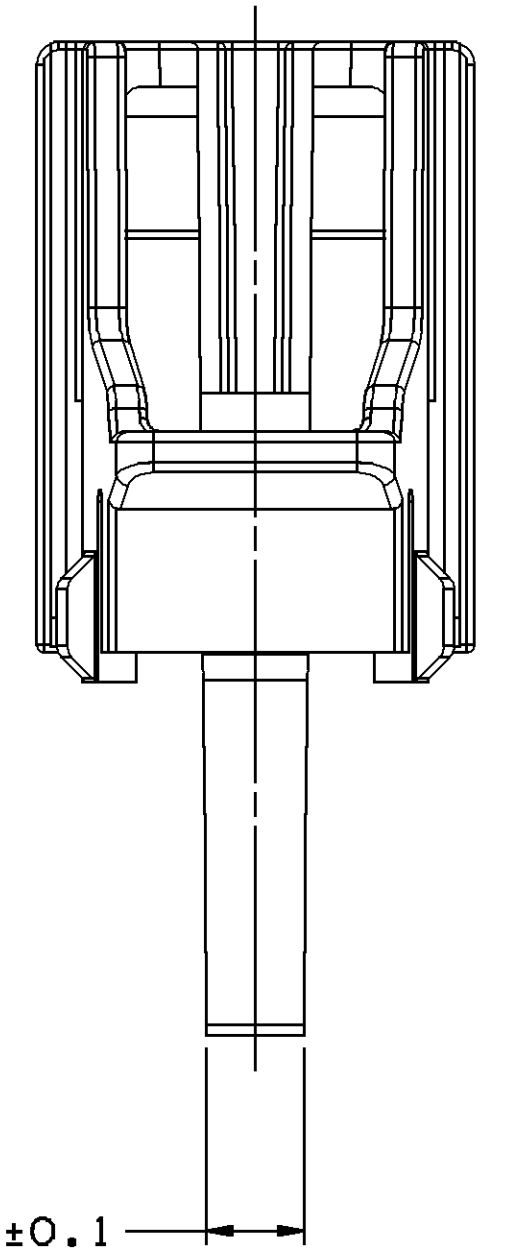

NOTES

- UNLESS OTHERWISE SPECIFIED AND/OR INDICATED: DIMENSIONS ARE TO FACE OF VIEW SHOWN AND AUTOMATICALLY ROUNDED BY COMPUTER FOR INSPECTION (SEE MATH MODEL FOR PRECISE DIMENSIONS). FOR ALL OTHER DIMENSIONS NOT SHOWN BUT REQUIRED FOR TOOL BUILD, SEE MATH MODEL FOR PRECISE TOOL PATH DATA.
- THIS PART USED IN ASSEMBLY 15419715 OR EQUIVALENT.
- MATERIAL RECYCLING CODE PER ISO 11469. (0.8)X(0.1) CHARACTERS AS SHOWN TO BE LOCATED ON ANY EXTERIOR SURFACE. OPTIONAL CONSTRUCTION TO BE NO MATERIAL RECYCLING CODE.
- THIS PART IS NOT CONTROLLED FOR AUTOMATIC FEEDING.
- MATING COMPONENTS OR EQUIVALENT: CONNECTOR 15423275
- (0.8)X(0.1) DELPHI CORPORATE BRAND TO BE LOCATED ON ANY EXTERIOR SURFACE, PREFERABLY VISIBLE AT FINAL ASSEMBLY. OPTIONAL CONSTRUCTION TO BE "PED" OR NO LOGO.

PART NO	REV	N/P	MATERIAL SPECIFICATION AND COLOR
15497403	02	AA	M3592012 PA66 HS IM GRN
15423276	02	AA	M3592015 PA66 HS IM GRN

DIMENSIONAL RANGE (MM)		CHART ET	
FROM	TO		
> 0	> 20	> 30	> 100
> 20	> 30	> 70	> 150
> 30	> 70	> 100	> 200
> 70	> 100	> 150	> 250
> 100	> 150	> 200	> 300
> 150	> 200	> 250	> 400

TOLERANCE UNLESS OTHERWISE SPECIFIED
 ±0.15 | ±0.2 | ±0.3 | ±0.4 | ±0.5 | ±0.6 | ±0.8 | ±1 | ±1.2
 ANGULAR TOLERANCE ±2°

DWG TYPE PART DRAWING	
STYLE	
VOLUME (CPI) 0.574	DISTR CODE D
UNLESS OTHERWISE SPECIFIED THIS DOCUMENT IS IN ACCORDANCE WITH ASME Y14.5M-1994 AS AMENDED BY THE 0M GLOBAL DIMENSIONING AND TOLERANCING ADDENDUM - 1997. ALL GEOMETRIC TOLERANCES AND RELATED DATUMS APPLY RFS. RULE #1 (PERFECT FORM AT MMC) DOES NOT APPLY WHEN RELATIONSHIP BETWEEN FEATURES IS ESTABLISHED BY ORIENTATION OR LOCATION TOLERANCES. SEPARATE POSITION CALLOUTS MAY BE GAGED SEPARATELY, REGARDLESS OF DATUM REFERENCE. ALL DIMENSIONS ARE IN MILLIMETERS	
REFERENCE	
THIRD ANGLE PROJECTION	DO NOT SCALE USE MATH DATA

DELPHI
 DELPHI PACKARD ELECTRICAL/ELECTRONIC ARCHITECTURE
 WARREN, OH

DR	DATE
APVD1 PABLO TRONCOSO	06JL04
APVD2 J. S. ALVARADO	09JL04
APVD3 R.M. FETCENKO	13JL04
APVD4	
APVD5	

SUBSTANCES OF CONCERN AND RECYCLED CONTENT PER DELPHI 10945001

MATERIAL SEE CHART

DRAWING NAME
TAXI LOCK CPA

DRAWING NUMBER
15497402

SIZE	SCALE	FRAME NO	SHEET NO	STG	REV	N/P
A1	5:1	1 OF 1	1 OF 1	R	04	-