



## Ferrites and accessories

### RM 4, RM 4 LP Cores and accessories

**Series/Type:** B65803, B65804, B65806, B65539

**Date:** June 2011

The following products presented in this data sheet are being withdrawn.

| Ordering Code     | Substitute Product | Date of Withdrawal | Deadline Last Orders | Last Shipments |
|-------------------|--------------------|--------------------|----------------------|----------------|
| B65804K1005D001   | B65804P1005D001    | 2011-04-19         |                      |                |
| B65804K1006D001   | B65804D1006D001    | 2011-04-19         |                      |                |
| B65804R1006D001V1 | B65804V1006D001    | 2011-04-19         |                      |                |

For further information please contact your nearest EPCOS sales office, which will also support you in selecting a suitable substitute. The addresses of our worldwide sales network are presented at [www.epcos.com/sales](http://www.epcos.com/sales).

|  |
|--|
| <b>RM 4</b>  |
| <b>Core</b> <span style="float: right;"><b>B65803</b></span> |

- To IEC 62317-4
- Core without center hole for transformer applications
- Delivery mode: sets

**Magnetic characteristics (per set)**

|              | with center hole | without center hole |                  |
|--------------|------------------|---------------------|------------------|
| $\Sigma l/A$ | 1.9              | 1.7                 | mm <sup>-1</sup> |
| $l_e$        | 21               | 22                  | mm               |
| $A_e$        | 11               | 13                  | mm <sup>2</sup>  |
| $A_{min}$    | —                | 11.3                | mm <sup>2</sup>  |
| $V_e$        | 231              | 286                 | mm <sup>3</sup>  |

**Approx. weight (per set)**

| m | 1.45 | 1.65 | g |
|---|------|------|---|
|---|------|------|---|

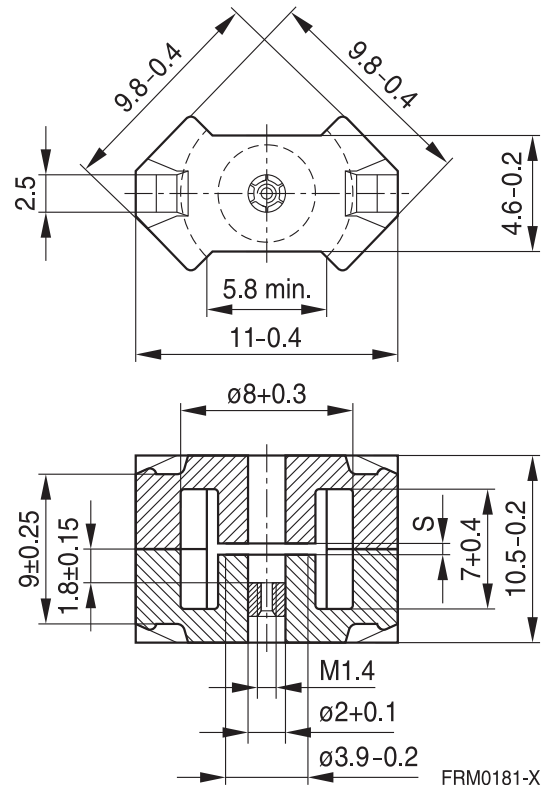

**Gapped**

| Material | $A_L$ value<br>nH | s<br>approx.<br>mm | $\mu_e$ | Ordering code <sup>1)</sup><br>-A with center hole<br>-N with threaded sleeve |
|----------|-------------------|--------------------|---------|---|
| K1       | 16 ± 3%           | 1.0                | 24.2    | B65803+0016A001   |
|          | 25 ± 3%           | 0.40               | 37.8    | B65803+0025A001   |
| M33      | 40 ± 3%           | 0.36               | 60.4    | B65803+0040A033   |
|          | 63 ± 3%           | 0.18               | 96      | B65803+0063A033   |
| N48      | 63 ± 3%           | 0.16               | 96      | B65803+0063A048   |
|          | 100 ± 3%          | 0.10               | 152     | B65803+0100A048   |
|          | 160 ± 3%          | 0.06               | 243     | B65803+0160A048   |

1) Replace the + by the code letter "A" or "N" for the required version.

**RM 4**
**Core**
**B65803**
**Ungapped**

| Material | $A_L$ value<br>nH | $\mu_e$ | $P_V$<br>W/set                   | Ordering code<br>-J without center hole |
|----------|-------------------|---------|----------------------------------|---|
| N45      | 1700 +30/-20%     | 2290    |                                  | B65803J0000R045                         |
| N30      | 1900 +30/-20%     | 2560    |                                  | B65803J0000R030                         |
| T35      | 2800 +40/-30%     | 3770    |                                  | B65803J0000Y035                         |
| T38      | 3700 +40/-30%     | 4980    |                                  | B65803J0000Y038                         |
| N49      | 750 +30/-20%      | 1010    | < 0.04 ( 50 mT, 500 kHz, 100 °C) | B65803J0000R049                         |
| N87      | 1100 +30/-20%     | 1480    | < 0.20 (200 mT, 100 kHz, 100 °C) | B65803J0000R087                         |
| N97      | 1100 +30/-20%     | 1480    | < 0.15 (200 mT, 100 kHz, 100 °C) | B65803J0000R097                         |

**Coil former**

Material: GFR thermosetting plastic (UL 94 V-0, insulation class to IEC 60085:  
 $H \triangleq$  max. operating temperature 180 °C), color code white  
 Bakelite UP 3420® [E61040 (M)], HEXION SPECIALTY CHEMICALS GMBH

Solderability: to IEC 60068-2-20, test Ta, method 1 (aging 3): 235 °C, 2 s

Resistance to soldering heat: to IEC 60068-2-20, test Tb, method 1B: 350 °C, 3.5 s

Winding: see Data Book 2007, chapter "Processing notes, 2.1"

Pins squared in the start-of-winding area.

For matching clamp and insulating washers see page 5.

| Sections | $A_N$<br>mm <sup>2</sup> | $l_N$<br>mm | $A_R$ value<br>$\mu\Omega$ | Pins   | Ordering code                      |
|----------|--------------------------|-------------|----------------------------|--------|------------------------------------|
| 1        | 7.7                      | 20          | 89                         | 5<br>6 | B65804P1005D001<br>B65804D1006D001 |

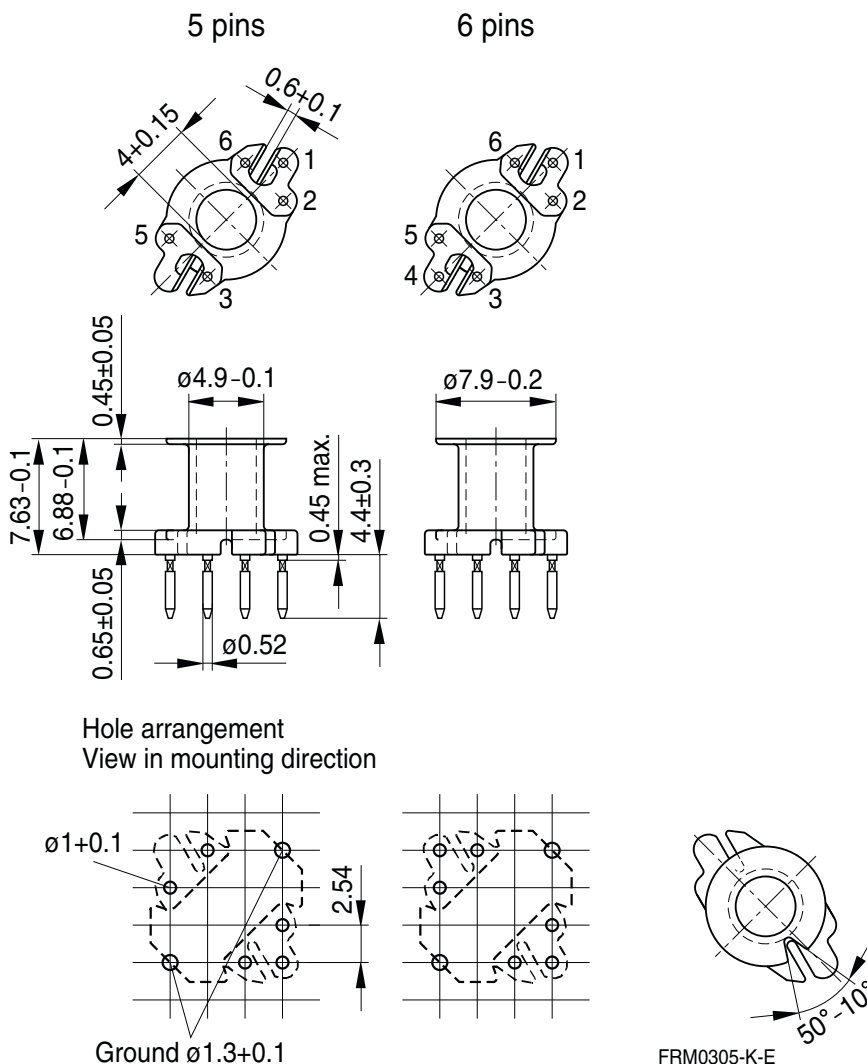

Hole arrangement  
View in mounting direction

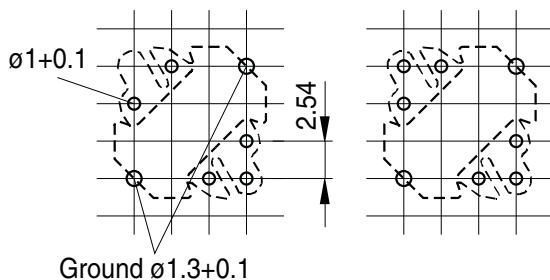

**Clamp**

- With ground terminal, made of stainless spring steel (tinned), 0.3 mm thick
- Solderability to IEC 60068-2-20, test Ta, method 1 (aging 3): 235 °C, 2 s
- Also available as strip clamp on reels on request

**Insulating washer 1 between core and coil former**

- For tolerance compensation and for insulation
- Made of polyarylate (UL 94 V-0, insulation class to IEC 60085: E  $\geq$  120 °C), 0.08 mm thick Aryphan F685, [E167358 (M)], natural color, LOFO HIGH TECH FILM GMBH

**Insulating washer 2 for double-clad PCBs**

- Made of polycarbonate film (UL 94 V-0, insulation class to IEC 60085: E  $\geq$  120 °C), 0.25 mm thick Makrofol FR, [E118859 (M)], natural color, BAYER MATERIALSCIENCE L L C

|   | Ordering code   |
|---|-----------------|
| Clamp (ordering code per piece, 2 are required) | B65806B2203X000 |
| Insulating washer 1 (reel packing, PU = 1 reel) | B65804A5000X000 |
| Insulating washer 2 (bulk)                      | B65804C2005X000 |

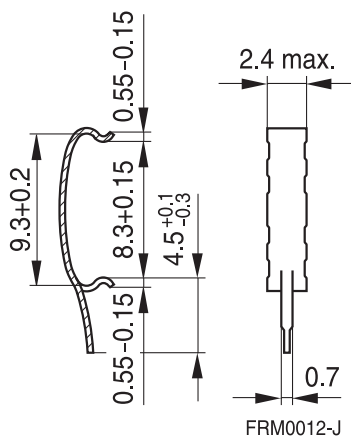
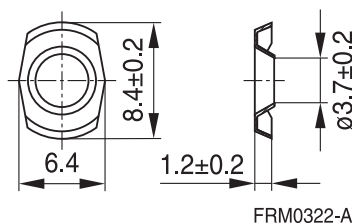
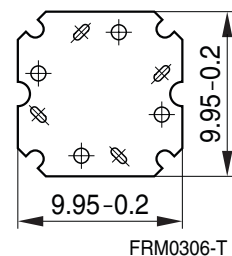
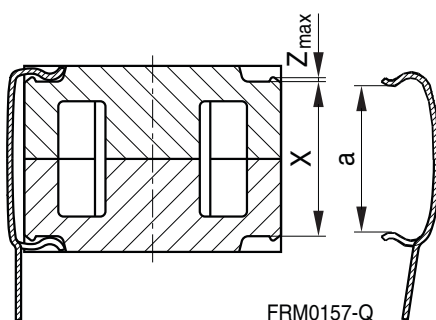
**Clamp**

**Insulating washer 1 (preliminary data)**

**Insulating washer 2**

**Clamping forces for RM 4**

$F_{\min}$ : Extension of clamp from  $a$  to  $a_2 = X_{\min}$   
 $F_{\max}$ : Extension of clamp from  $a$  to  $a_1 = X_{\max}$

|                              |            |      |
|------------------------------|------------|------|
| Clamp opening $a$ (mm)       | 8.3 +0.15  |      |
| Core nose $Z_{\max}$ (mm)    | 0.15       |      |
| Height of core pair $X$ (mm) | $X_{\min}$ | 8.75 |
|                              | $X_{\max}$ | 9.25 |
| Clamping force $F$ (N)       | $F_{\min}$ | 5    |
|                              | $F_{\max}$ | 40   |

**Adjusting screw**

- Tube core with thread and core brake made of GFR polyterephthalate  
Pocan B3235® [E245249 (M)], LANXESS AG

| Figure | Tube core       |          |            | Ordering code   |
|--------|-----------------|----------|------------|-----------------|
|        | ∅ × length (mm) | Material | Color code |                 |
| a      | 1.81 × 2.0      | K1       | yellow     | B65539C1003X001 |
| a      | 1.81 × 2.7      | K1       | gray       | B65539C1002X001 |
| a      | 1.81 × 2.7      | N22      | red        | B65539C1002X022 |
| b      | 1.81 × 3.4      | N22      | green      | B65806C3001X022 |

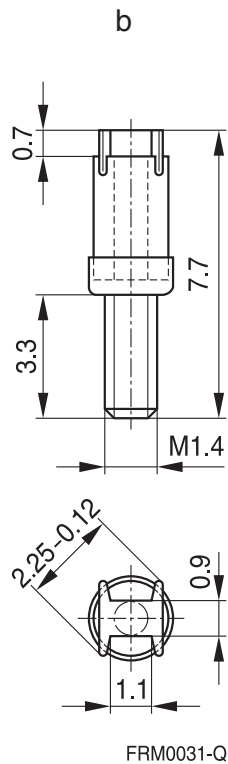
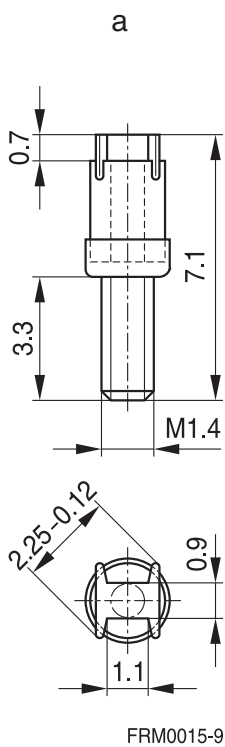

**RM 4 »Low Profile«**
**Core**
**B65803P**

- To IEC 62317-4
- For compact transformers with high inductance
- Without center hole
- Delivery mode: sets

**Magnetic characteristics (per set)**

$$\Sigma l/A = 1.2 \text{ mm}^{-1}$$

$$l_e = 17.3 \text{ mm}$$

$$A_e = 14.5 \text{ mm}^2$$

$$A_{\min} = 11.3 \text{ mm}^2$$

$$V_e = 251 \text{ mm}^3$$

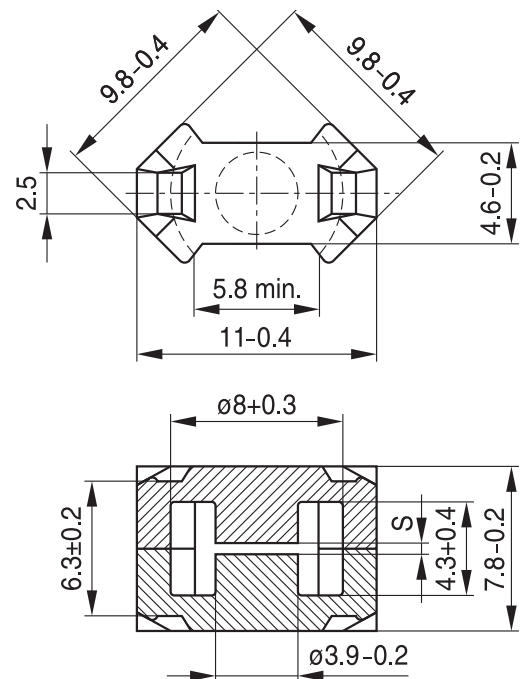
**Approx. weight 1.2 g/set**

FRM0149-Z

**Ungapped**

| Material | $A_L$ value<br>nH | $\mu_e$ | $P_V$<br>W/set                   | Ordering code   |
|----------|-------------------|---------|----------------------------------|-----------------|
| T38      | 5000 +40/-30%     | 4750    |                                  | B65803P0000Y038 |
| N49      | 950 +30/-20%      | 900     | < 0.04 ( 50 mT, 500 kHz, 100 °C) | B65803P0000R049 |
| N92      | 1000 +30/-20%     | 950     | < 0.14 (200 mT, 100 kHz, 100 °C) | B65803P0000R092 |
| N87      | 1300 +30/-20%     | 1230    | < 0.12 (200 mT, 100 kHz, 100 °C) | B65803P0000R087 |

### Clamp

- With ground terminal, made of stainless spring steel (tinned), 0.3 mm thick,  
Without ground terminal, made of stainless spring steel, 0.3 mm thick
- Solderability to IEC 60068-2-20, test Ta, method 1 (aging 3): 235 °C, 2 s
- Clamping force 40 N per pair of clamps (typical value)
- Also available as strip clamp on reels on request

### Insulating washer 1 between core and coil former

- For tolerance compensation and for insulation
- Made of polyarylate film (UL 94 V-0, insulation class to IEC 60085: E  $\geq$  120 °C), 0.08 mm thick  
Aryphan F685, [E167358 (M)], natural color, LOFO HIGH TECH FILM GMBH

### Insulating washer 2 for double-clad PCBs

- Made of polycarbonate (UL 94 V-0, insulation class to IEC 60085: E  $\geq$  120 °C), 0.25 mm thick  
Makrofol FR, [E118859 (M)], natural color, BAYER MATERIALSCIENCE L L C

|   | Ordering code   |
|---|-----------------|
| Clamp with ground terminal (ordering code per piece, 2 are required)    | B65804P2203X000 |
| Clamp without ground terminal (ordering code per piece, 2 are required) | B65804P2204X000 |
| Insulating washer 1 (reel packing, PU = 1 reel)                         | B65804A5000X000 |
| Insulating washer 2 (bulk)  | B65804C2005X000 |

### Clamp with ground terminal

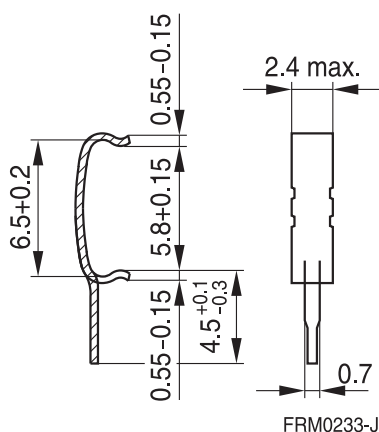

### Clamp without ground terminal

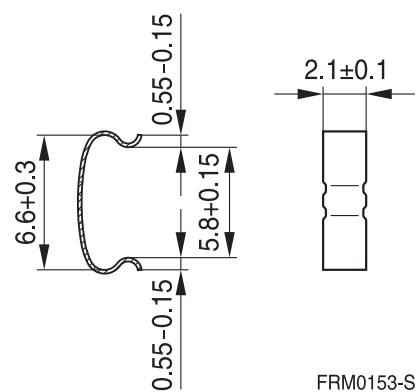

### Insulating washer 1 (preliminary data)

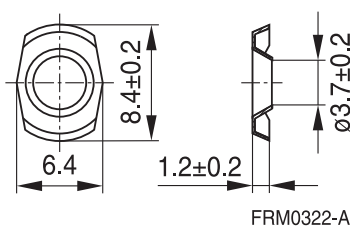

### Insulating washer 2

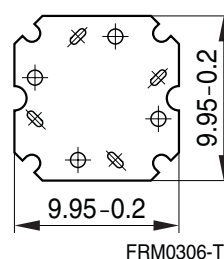



**SMD coil former with J terminals**

Material: GFR liquid crystal polymer (UL 94 V-0, insulation class to IEC 60085:  
 $F \triangleq$  max. operating temperature 155 °C), color code black  
 Vectra C 130 [E83005 (M)], TICONA

Solderability: to IEC 60068-2-58, test Td, method 6 (Group 3): 245 °C, 3 s

Resistance to soldering heat: to IEC 60068-2-58, test Td, method 6 (Group 3): 255 °C, 10 s  
 permissible soldering temperature for wire-wrap connection on coil former: 400 °C, 1 s

Winding: see Data Book 2007, chapter "Processing notes, 2.1"

**Clamp**

- Without ground terminal, made of stainless spring steel, 0.3 mm thick
- Also available as strip clamp (each carton containing 2 reels)

| Sections  | $A_N$<br>mm <sup>2</sup> | $l_N$<br>mm | $A_R$ value<br>$\mu\Omega$ | Terminals <sup>1)</sup> | Ordering code   |
|---|--------------------------|-------------|----------------------------|-------------------------|-----------------|
| 1   | 5.0                      | 20.1        | 138                        | 10                      | B65804B6010T001 |
| 2   | 4.4                      | 20.1        | 157                        | 10                      | B65804B6010T002 |
| Clamp (ordering code per piece, 2 are required) |                          |             |                            |                         | B65804P2204X000 |

**Coil former**

1 section

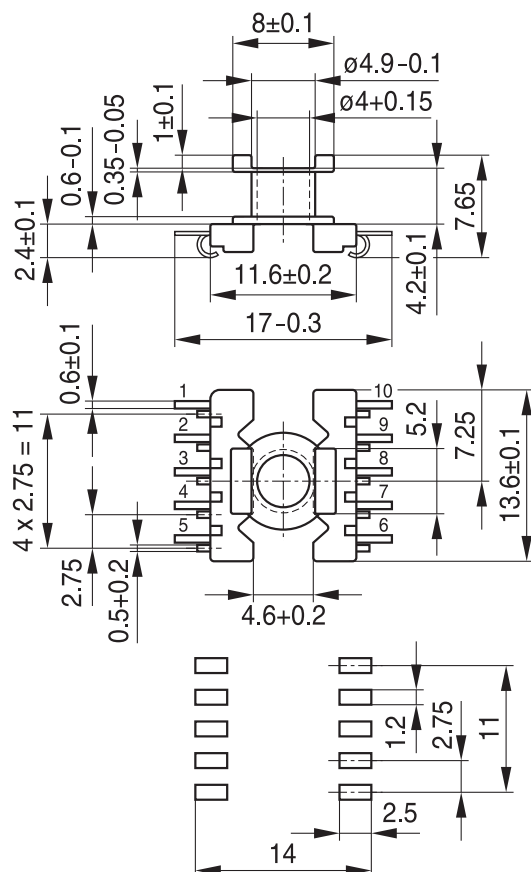

2 sections

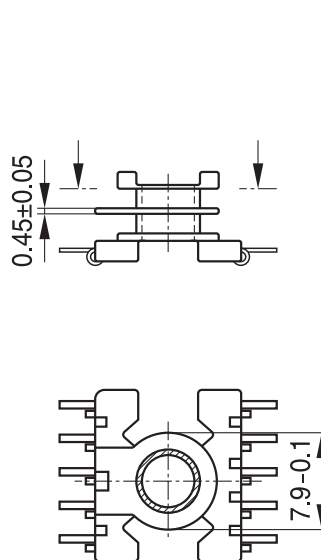
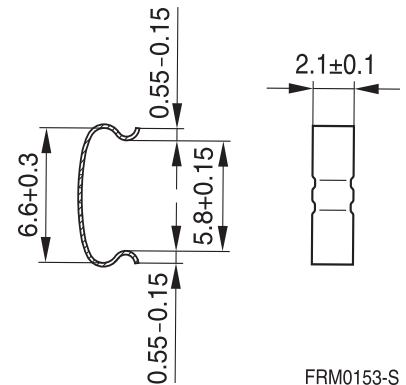
**Clamp**

FRM0153-S

 Recommended  
 PCB layout

FRM0258-5

1) 6 and 8 terminals on request

**Mechanical stress and mounting**

Ferrite cores have to meet mechanical requirements during assembling and for a growing number of applications. Since ferrites are ceramic materials one has to be aware of their special behavior under mechanical load.

Just like any ceramic material, ferrite cores are brittle and sensitive to any shock, fast changing or tensile load. Especially fast cooling rates under ultrasonic cleaning, high static and cyclic loads can cause cracks or failure of the ferrite cores.

For detailed information see Data Book 2007, chapter "General - Definitions, 8.1".

**Effects of core combination on  $A_L$  value**

Stresses in the core affect not only the mechanical but also the magnetic properties. It is apparent that the initial permeability is dependent on the stress state of the core. The higher the stresses are in the core, the lower the value for the initial permeability. Thus, the embedding medium should offer the greatest possible elasticity.

For detailed information see Data Book 2007, chapter "General - Definitions, 8.2".

**Heating up**

Ferrites can run hot during operation at higher flux densities and higher frequencies.

**NiZn-materials**

The magnetic properties of NiZn-materials can change irreversibly when exposed to strong magnetic fields.

**Processing notes**

- The start of the winding process should be soft. Otherwise, the flanges may be destroyed.
- Excessive winding forces may damage the flanges or squeeze the tube so that the cores can no longer be mounted.
- Excessive soldering time at high temperature (>300 °C) may affect coplanarity or pin arrangement.
- Not following the processing notes for soldering of the J-leg terminals may cause solderability problems at the transformer because of contamination with tin oxide (SnO) from the tin bath or burned insulation from the wire. For detailed information see Data Book 2007, chapter "Processing notes, 2.2".
- The dimensions of the pin hole arrangement are fixed and should be understood as an ideal recommendation for drilling the printed circuit board. In order to avoid problems when mounting the transformer, customers should make allowances for manufacturing tolerances in the drilling and pick-and-place processes by increasing the diameter of the pin holes.

## Important notes

The following applies to all products named in this publication:

1. Some parts of this publication contain **statements about the suitability of our products for certain areas of application**. These statements are based on our knowledge of typical requirements that are often placed on our products in the areas of application concerned. We nevertheless expressly point out **that such statements cannot be regarded as binding statements about the suitability of our products for a particular customer application**. As a rule, EPCOS is either unfamiliar with individual customer applications or less familiar with them than the customers themselves. For these reasons, it is always ultimately incumbent on the customer to check and decide whether an EPCOS product with the properties described in the product specification is suitable for use in a particular customer application.
2. We also point out that **in individual cases, a malfunction of electronic components or failure before the end of their usual service life cannot be completely ruled out in the current state of the art, even if they are operated as specified**. In customer applications requiring a very high level of operational safety and especially in customer applications in which the malfunction or failure of an electronic component could endanger human life or health (e.g. in accident prevention or life-saving systems), it must therefore be ensured by means of suitable design of the customer application or other action taken by the customer (e.g. installation of protective circuitry or redundancy) that no injury or damage is sustained by third parties in the event of malfunction or failure of an electronic component.
3. **The warnings, cautions and product-specific notes must be observed.**
4. In order to satisfy certain technical requirements, **some of the products described in this publication may contain substances subject to restrictions in certain jurisdictions (e.g. because they are classed as hazardous)**. Useful information on this will be found in our Material Data Sheets on the Internet ([www.epcos.com/material](http://www.epcos.com/material)). Should you have any more detailed questions, please contact our sales offices.
5. We constantly strive to improve our products. Consequently, **the products described in this publication may change from time to time**. The same is true of the corresponding product specifications. Please check therefore to what extent product descriptions and specifications contained in this publication are still applicable before or when you place an order.

We also **reserve the right to discontinue production and delivery of products**. Consequently, we cannot guarantee that all products named in this publication will always be available. The aforementioned does not apply in the case of individual agreements deviating from the foregoing for customer-specific products.

6. Unless otherwise agreed in individual contracts, **all orders are subject to the current version of the “General Terms of Delivery for Products and Services in the Electrical Industry” published by the German Electrical and Electronics Industry Association (ZVEI)**.
7. The trade names EPCOS, BAOKE, Alu-X, CeraDiode, CSMP, CSSP, CTVS, DeltaCap, DigiSiMic, DSSP, MiniBlue, MiniCell, MKK, MLSC, MotorCap, PCC, PhaseCap, PhaseCube, PhaseMod, PhiCap, SIFERRIT, SIFI, SIKOREL, SilverCap, SIMDAD, SiMic, SIMID, SineFormer, SIOV, SIP5D, SIP5K, ThermoFuse, WindCap are **trademarks registered or pending** in Europe and in other countries. Further information will be found on the Internet at [www.epcos.com/trademarks](http://www.epcos.com/trademarks).

## X-ON Electronics

Largest Supplier of Electrical and Electronic Components

*Click to view similar products for [Ferrite Cores & Accessories](#) category:*

*Click to view products by [EPCOS](#) manufacturer:*

Other Similar products are found below :

[B65512C0000T001](#) [B65522B0000T001](#) [B65549E4X23](#) [B65615B0001X000](#) [B65659F0001X023](#) [B65659F0003X023](#) [B65659F4X23](#)  
[B65665C0004X000](#) [B65679E3X22](#) [B65705B0003X000](#) [B65804C2005X000](#) [B65812B3003X22](#) [B65814B2005X000](#) [B65840B1006D001](#)  
[B65840B1006D002](#) [B65878E0012D001](#) [B66206A2001X000](#) [B66206J1106T1](#) [B66208K1009T1](#) [B66252BM1](#) [B66288F2204X000](#)  
[B66306C1010T2](#) [B66341G0000X127](#) [B66390A1016T001](#) [B67348A1X27](#) [B65512C2001X000](#) [B65518D2001X000](#) [B65535B0003X000](#)  
[B65539C1003X1](#) [B65542A5000X](#) [B65655B0009X000](#) [B65687A1000T001](#) [B65714K1020T001](#) [B65734B1000T001](#) [B65734B1000T1](#)  
[B65804B6010T1](#) [B65814N1008D002](#) [B65816N1011D1](#) [B65820D2005X](#) [B65822F1008T001](#) [B65844W1010D001](#) [B65848D1010D1](#)  
[B65848S2000X](#) [B65884E0012D001](#) [B65887H4300X041](#) [B66202A2010X000](#) [B66202B1106T001](#) [B66206B1110T001](#) [B66208K1009T001](#)  
[B66208X1010T001](#)