

ELFF SERIES PART NUMBERING SCHEME

REV	ECN	APPD
-	3600	JC 12/11/98
A	4686	IQ 1/2/02
B	4792	IQ 3/11/02
C	4821	IQ 4/9/02
D	5742	JN 12/28/05

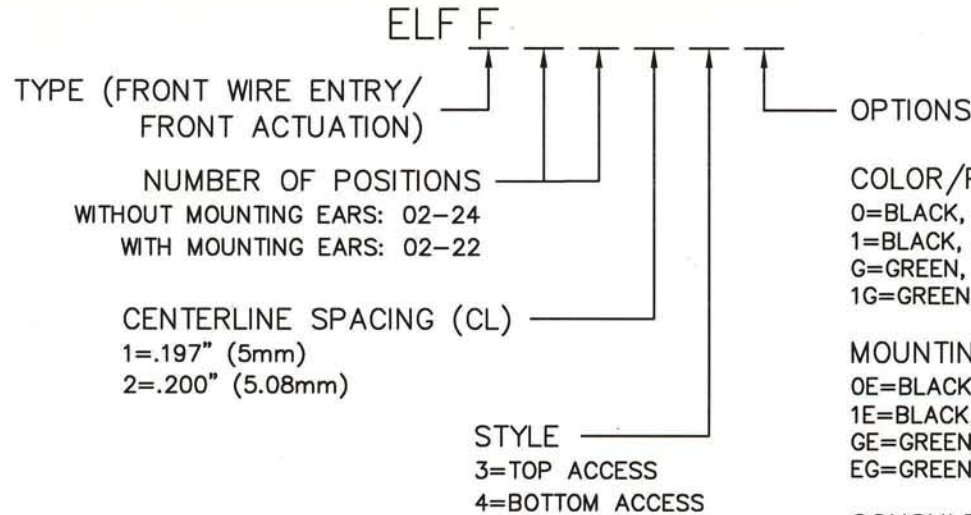

COLOR/PLATING
 0=BLACK, TIN (STANDARD)
 1=BLACK, SELECTIVE GOLD
 G=GREEN, TIN
 1G=GREEN, SEL. GOLD

MOUNTING EARS
 0E=BLACK, TIN
 1E=BLACK, SEL. GOLD
 GE=GREEN, TIN
 EG=GREEN, SEL. GOLD

CONSULT PCD FOR PART NO. AND AVAILABILITY OF FOLLOWING OPTIONS:

- * CUSTOM COLORS
- * CUSTOM MARKING
- * CUSTOM KEYING
- * SELECTIVE CONTACT LOADING

RU

RATINGS

CURRENT - 15A
 VOLTAGE - 300V
 U.L. FILE NO. E83421

SP

RATINGS

CURRENT - 15A
 VOLTAGE - 300V
 CSA FILE NO. LR69703

DIN VDE 0627:1986
 DIN VDE 0110-1:1989
 EN 60947-1:1991
 EN 60947-7-1:1992

CURRENT - 15A
 VOLTAGE - 300V
 TUV FILE NO. 20396

INSTALLATION RECOMMENDATIONS:
 WIRE RANGE: AWG #14-26, STRANDED OR SOLID;
 AWG #12 STRANDED
 WIRE STRIP LENGTH: AWG #14-26: .310" (7,87mm)
 AWG #12: .490" (12,45mm)
 TIGHTENING TORQUE: 7 LB-IN.

MATERIALS:
 HOUSING: PPO, UL 94 V-0
 CONTACT: COPPER ALLOY, OPTIONAL FINISH
 SCREW: STEEL, NICKEL FINISH
 WIRE CLAMP: COPPER ALLOY, NICKEL FINISH

MAX OPERATING TEMPERATURE:
 105°C

DIMENSIONS
 ANSI Y14.5M
 UNITS: INCHES
 ACAD FILE

TOLERANCES
 .XX ±.01
 .XXX ±.005
 ANGLES ±2°

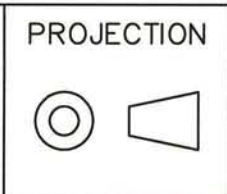

Amphenol Pcd
 SPECIFICATION DRAWING

ENGR
 A. PATRIE 12/4/98

TITLE

ELFF SERIES
 PLUGGABLE TERMINAL BLOCK
 FRONT / FRONT

ORIGINAL
 STAMPED
 IN RED

*THIS DOCUMENT CONTAINS
 PROPRIETARY INFORMATION WHICH
 IS THE CONFIDENTIAL PROPERTY
 OF AMPHENOL PCD INC. PEABODY, MA*

CHKD
 APPD
 J. CAHALY 12/11/98

SIZE A	DWG NO. ELFF02130	REV D
CODE: 58982	SCALE: NONE	SHEET 1 OF 2

WITHOUT MOUNTING EARS

L=NUM OF POS X CL SPACING

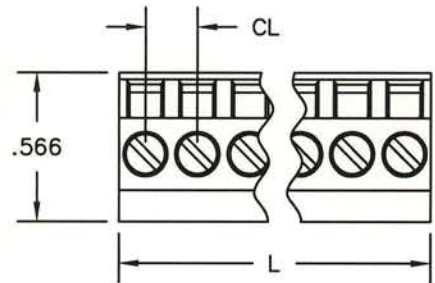
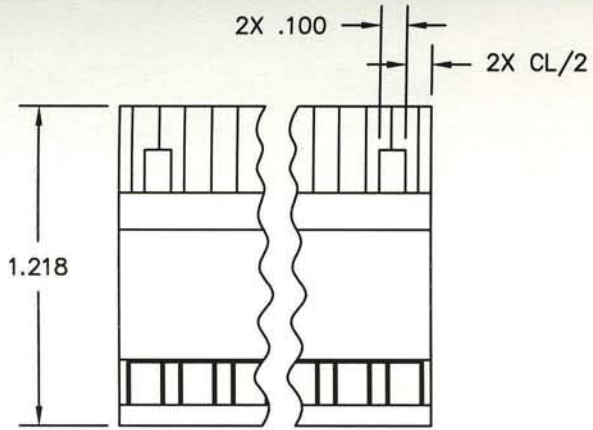

TOP ACCESS

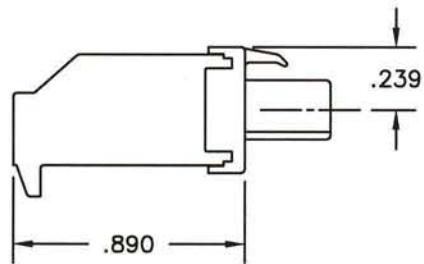

BOTTOM ACCESS

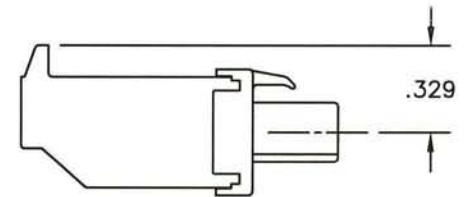

WITH MOUNTING EARS

L=NUM OF POS X CL SPACING

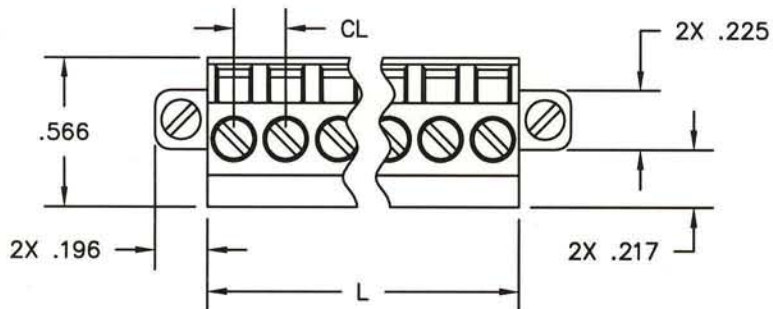
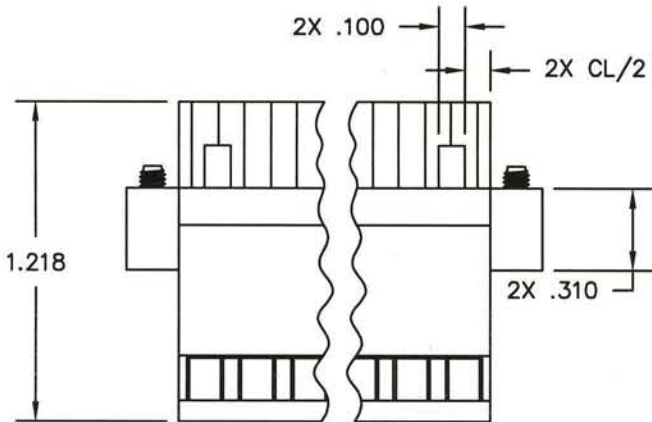

TOP ACCESS

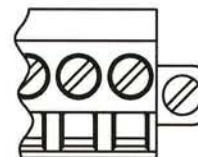
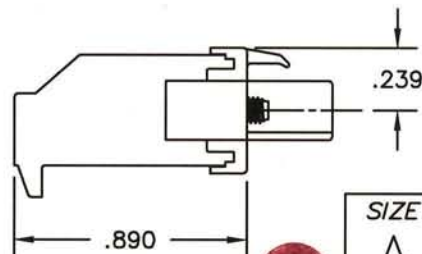

BOTTOM ACCESS

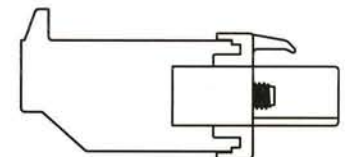

SIZE

DWG NO.

REV

A

ELFF02130

D

CODE: 58982

SCALE: NONE

SHEET 2 OF 2

X-ON Electronics

Largest Supplier of Electrical and Electronic Components

Click to view similar products for [Pluggable Terminal Blocks](#) category:

Click to view products by [Amphenol](#) manufacturer:

Other Similar products are found below :

[57.404.7553](#) [57.504.0053.7](#) [57.510.0053](#) [57.910.6153](#) [01.112.1453](#) [CTB932VE/6](#) [MC 1.5/ 6-ST-3.5 GY AU](#) [ET02015000J0G](#) [734-104](#) [734-302](#) [734-304](#) [8-141-P](#) [FKCT 2.5/ 3-ST KMGY](#) [860505](#) [860508](#) [860516](#) [860810](#) [861908](#) [GBPACX-12](#) [93.731.4953.0](#) [PV05-5,08-K](#) [PVP02-5,00](#) [PVP04-3,50](#) [PVS02-5,00](#) [1-1986160-3](#) [H-10](#) [1546228-5](#) [ELFH09150](#) [ELFH16150](#) [ELFP03110](#) [ELFT06250](#) [ELFT07250](#) [ELVF09400](#) [ELVP03100](#) [ELXH03100](#) [ELXH071G0E](#) [ELXP041G0](#) [ELXT046G0](#) [1700101](#) [1700410](#) [1700425](#) [1703176](#) [1705229](#) [1710175](#) [1714537](#) [1717806](#) [1719600](#) [1729386](#) [1734692](#) [1734795](#)