

Rev	AWG #	Description	Date	Appr
-		RELEASED	4/12/05	

APPROVED: _____
 DATE: _____ TITLE: _____

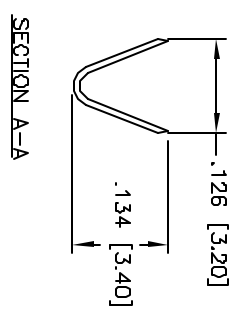
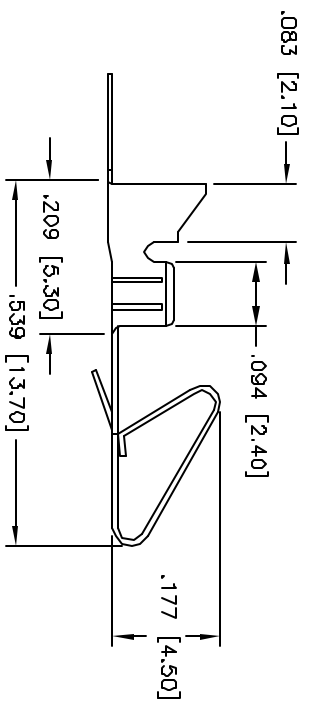
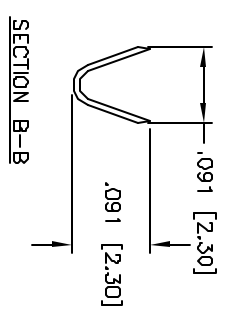
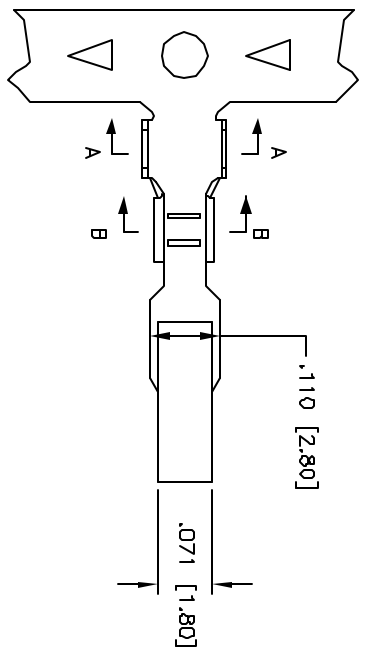

Packaging:
 B = 1,000 pieces loose cut
 R = 6,000 pieces on reel

SPECIFICATIONS:
 Material:
 Contact: Brass
 Plating:
 Tin over Copper underplate overall
 Electrical:
 Wire range: 18-24 AWG
 Current rating: 5 Amps max
 Contact resistance: 10 mohms max
 Dielectric withstanding voltage: 1,500 VAC for 1 minute
 Temperature Rating:
 Operating temperature: -25°C to +85°C
 Environmental:
 Lead free, RoHS compliant



UNLESS OTHERWISE SPECIFIED ALL DIMENSIONS ARE NICHES [MM] TOLERANCES: EXCEPT AS NOTED INCHES .10 ±.010 .020 ±.010 .015 ±.010 .010 ±.010 .010 ±.010 .010 ±.010		DATE 4/12/05		TITLE CRIMP CONTACT	
DRAWN	SS	SIZE	PART NO.	REV.	
CHECKED		X	MTB-CX	-	
APPROVED		REF:	SCALE: NIB	SHEET 1 OF 1	

ADAM TECH
 909 Rahway Avenue, Union, NJ 07083
 Phone: 908-887-5000 Fax: 908-887-5710

6 5 4 3 2 1

X-ON Electronics

Largest Supplier of Electrical and Electronic Components

Click to view similar products for [I/O Connectors](#) category:

Click to view products by [Adam](#) manufacturer:

Other Similar products are found below :

[571763P](#) [58098-0628](#) [61-168618-12P](#) [D38999/20FJ29SB L/C](#) [72.250.1628.2](#) [72.250.2428.2](#) [74720-0505](#) [747680210](#) [76.350.0729.0](#) [76871-1403](#) [FCN-244F080-G/1](#) [FCN-260A9920](#) [FCN-268D024-G/2F#10X-R10](#) [MP-5T180MUNNA-005](#) [MP-5XRJ45UNNB-003](#) [PCS-E50FA](#) [PCS-XE26LKA](#) [PCS-XE26MA+](#) [PCS-XES68MS+](#) [G38A71314B](#) [91-569719-35R](#) [9776-18-6](#) [DX40-50P\(55\)](#) [1571250010](#) [157-22500-3](#) [MS3471L14-19P L/C](#) [171224-6031](#) [1888020-8](#) [91-569786-35H](#) [91-569786-35M](#) [91-644626-35P](#) [172501-4002](#) [172501-6002](#) [FCN-260C008-A/L0](#) [FCN-260C024-AL0](#) [FCN-261Z008](#) [FCN-268D008-G/1K](#) [2000314-1](#) [200331-1](#) [2007498-2](#) [PCR-E28LMDAG1+](#) [PCR-E36FC+](#) [PCS-E28FS+](#) [PCS-XE26SLFD+](#) [PCS-XE26SLFDT+](#) [G38A71214B](#) [HDRA-E68W1LFDTC-SL+](#) [HDR-E14MSG1+](#) [R88A-CNK81S](#) [CRT1-ATT02](#)