

NOTES:

1. Ⓢ REPRESENTS A CRITICAL DIMENSION.
2. MAXIMUM ALLOWABLE BOW: 0.005 [0.13] IN/IN AFTER ASSEMBLY.
3. MAXIMUM PIN ROTATION IN BODY: 2°
4. MINIMUM PUSHOUT FORCE: 1LB
5. CUT PARTS WITH METAL WASHERS TOWARDS OPERATOR ALLOWING FLASH TO BE ON POST AWAY FROM CRITICAL AREA (METAL WASHERS).
6. INSERT PINS SO THAT BANDOLIERS MARKS ARE LIMITED IN THE POST AREA (SEE TABLE 3).

DO NOT SCALE FROM THIS PRINT

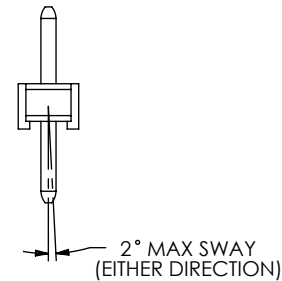
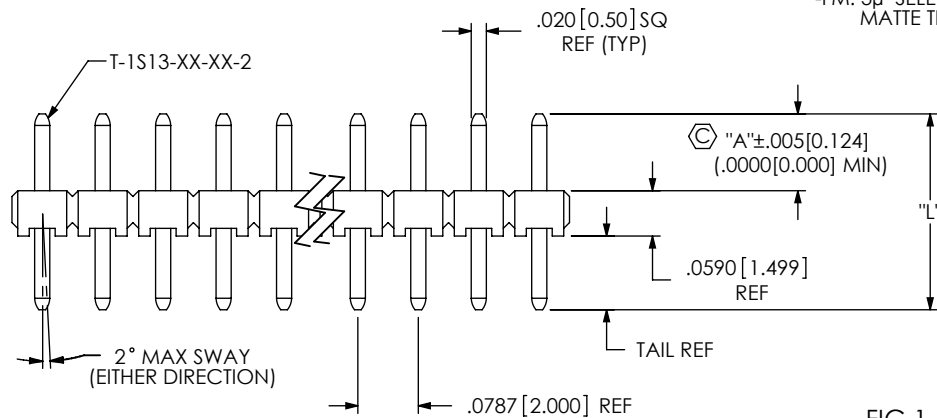
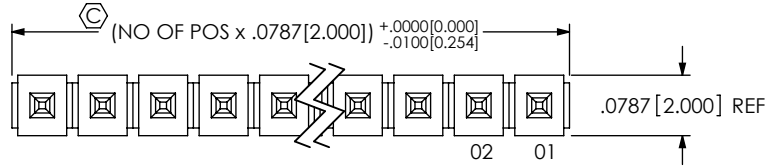

MTMM-1XX-XX-XX-X-XXX-XX-XXX

No OF POSITIONS
-01 THRU -50

TERMINAL SPEC
LEAD STYLE (SEE TABLE 1)

PLATING SPECIFICATION

- G: 20μ" SELECTIVE GOLD IN CONTACT AREA, 3μ" SELECTIVE GOLD ON TAIL.
- T: MATTE TIN ON CONTACT AND TAIL.
- S: 30μ" SELECTIVE GOLD IN CONTACT AREA, MATTE TIN ON TAIL.
- L: 15μ" SELECTIVE GOLD IN CONTACT AREA, MATTE TIN ON TAIL.
- F: 3μ" SELECTIVE GOLD IN CONTACT AREA, MATTE TIN ON TAIL.
- H: 30μ" SELECTIVE GOLD IN CONTACT AREA, 3μ" SELECTIVE GOLD ON TAIL.
- SM: 30μ" SELECTIVE GOLD IN CONTACT AREA, MATTE TIN ON TAIL.
- TM: MATTE TIN ON CONTACT AND TAIL.
- LM: 15μ" SELECTIVE GOLD IN CONTACT AREA, MATTE TIN ON TAIL.
- FM: 3μ" SELECTIVE GOLD IN CONTACT AREA, MATTE TIN ON TAIL.

OPTION
POLARIZATION
SPECIFY POS -XXX TO BE OMITTED

OPTION
**-MW: METAL WASHER
(-D & -Q BODY SPECS ONLY)
(SEE FIG 4, SHT 2)
(30 POS PER ROW MAX)
TAIL MUST BE .090 [2.29] - .300 [7.62]

POST HEIGHT
XXX = "A" (SEE TABLE 1)

BODY SPECIFICATION

- S: SINGLE (TMM-50-S, SEE FIG 1)
- D: DOUBLE (TMM-50-D, SEE FIG 2, SHT 2)
- Q: QUAD (TMM-50-Q, SEE FIG 3, SHT 2)

** -MW OPTION, DO NOT DESIGN IN. SAMTEC WILL ONLY SUPPORT EXISTING BUSINESS 02/08/2002

FIG 1
-S: SINGLE ROW OPTION
MTMM-1XX-02-XX-S-100 SHOWN

TABLE 1

LEAD STYLE	"A" MAX	PIN LENGTH "L"	TERMINAL
-02	0.196 [4.98]	0.255 [6.48]	T-1S13-04-XX-2
-03	0.243 [6.17]	0.302 [7.67]	T-1S13-07-XX-2
-04	0.264 [6.71]	0.323 [8.20]	T-1S13-20-XX-2
-05	0.318 [8.08]	0.377 [9.58]	T-1S13-02-XX-2
-06	0.338 [8.59]	0.397 [10.08]	T-1S13-05-XX-2
-07	0.397 [10.08]	0.456 [11.58]	T-1S13-13-XX-2
-08	0.417 [10.59]	0.476 [12.09]	T-1S13-08-XX-2
-09	0.476 [12.09]	0.535 [13.59]	T-1S13-03-XX-2
-10	0.496 [12.60]	0.555 [14.10]	T-1S13-06-XX-2
-11	0.535 [13.59]	0.594 [15.09]	T-1S13-09-XX-2
-12	0.555 [14.10]	0.614 [15.60]	T-1S13-14-XX-2
-13	0.614 [15.60]	0.673 [17.09]	T-1S13-10-XX-2
-14	0.692 [17.58]	0.751 [19.08]	T-1S13-11-XX-2
-15	0.771 [19.58]	0.830 [21.08]	T-1S13-12-XX-2

"A" MAX = "L" -.059 [1.50] (BODY) TAIL CAN BE .000

UNLESS OTHERWISE SPECIFIED, DIMENSIONS ARE IN INCHES. TOLERANCES ARE:
DECIMALS ANGLES
.XX: ±.01 [0.3] 2°
.XXX: ±.005 [0.13]
.XXXX: ±.0020 [0.051]

PROPRIETARY NOTE

THIS DOCUMENT CONTAINS INFORMATION CONFIDENTIAL AND PROPRIETARY TO SAMTEC, INC. AND SHALL NOT BE REPRODUCED OR TRANSFERRED TO OTHER DOCUMENTS OR DISCLOSED TO OTHERS OR USED FOR ANY PURPOSE OTHER THAN THAT WHICH IT WAS OBTAINED WITHOUT THE EXPRESSED WRITTEN CONSENT OF SAMTEC, INC.

MATERIAL: DO NOT SCALE DRAWING
INSULATOR: LCP, UL 94 VO, COLOR: BLACK
TERMINAL: PHOS BRONZE

SHEET SCALE: 4:1



520 PARK EAST BLVD, NEW ALBANY, IN 47150
PHONE: 812-944-6733 FAX: 812-948-5047
e-Mail: info@SAMTEC.com code 53322

DESCRIPTION:
2MM TERMINAL STRIP ASSEMBLY

DWG. NO.
MTMM-1XX-XX-XX-X-XXX-XX-XXX

BY: REIDINGER 12/01/1993 SHEET 1 OF 2

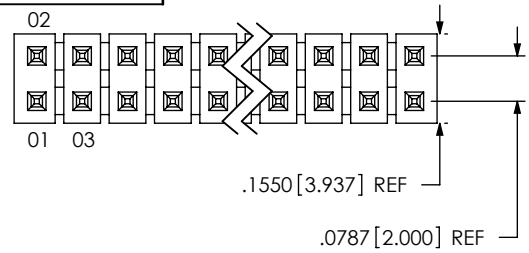

FIG 2
 -D: DOUBLE ROW OPTION
 MTMM-1XX-02-XX-D-100 SHOWN
 (SAME AS FIG 1, DIFFERENT AS SHOWN)

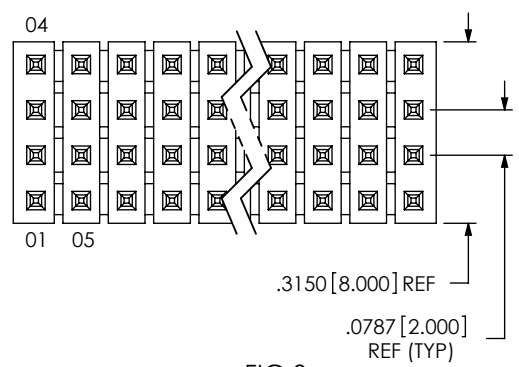

FIG 3
 -Q: QUAD ROW OPTION
 MTMM-1XX-02-XX-Q-100 SHOWN
 (SAME AS FIG 1, DIFFERENT AS SHOWN)

PACKAGING TABLE 2 FOR -MW OPTION ONLY

BODY SPECIFICATION	LEAD STYLE	PKG TUBE	TUBE PLUG
-D	-02, -03, -04, -05, -06	PT-1-24-02-17	TP-09
	-07, -08, -09, -10,	PT-1-24-03-75	TP-03
	-11, -12, -13, -14	PT-1-24-02-48	TP-03
	-15	PT-1-24-02-47	TP-03
-Q	-02, -03, -04, -05, -06	PT-1-24-02-17	TP-09
	07, -08, -09	PT-1-24-01-40	TP-24
	-10, -11	PT-1-24-02-29	TP-24
	-12, -13, -14, -15	PT-1-24-02-51	TP-07

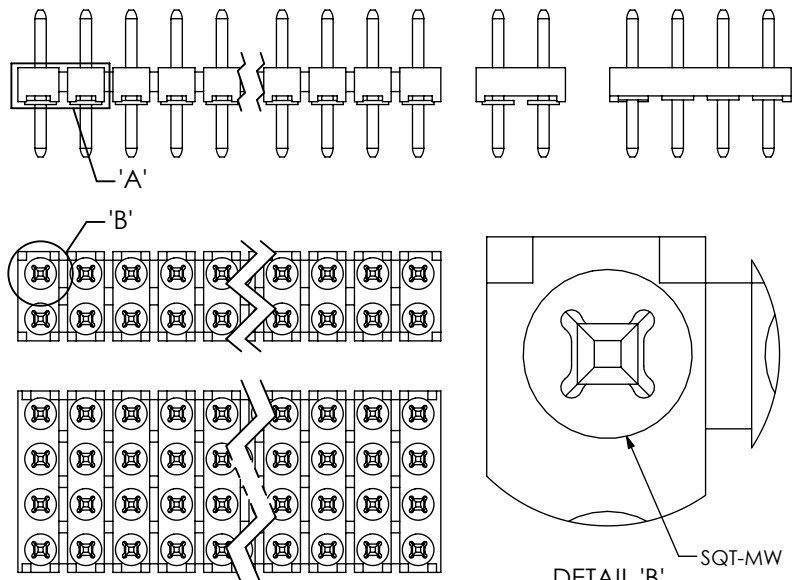

FIG 4
 -MW: METAL WASHER OPTION
 MTMM-1XX-02-XX-X-100-MW SHOWN
 (ONE PER POSITION)
 (-D & -Q BODY SPEC ONLY, SEE NOTE 5)
 (SAME AS FIG 1, DIFFERENT AS SHOWN)
 ** -MW OPTION, DO NOT DESIGN IN. SAMTEC WILL ONLY SUPPORT EXISTING BUSINESS 02/08/2002

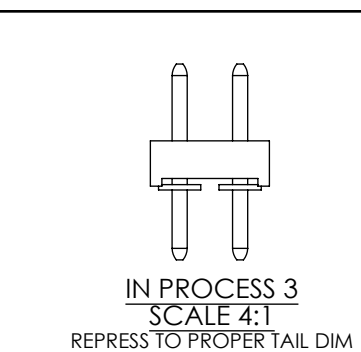
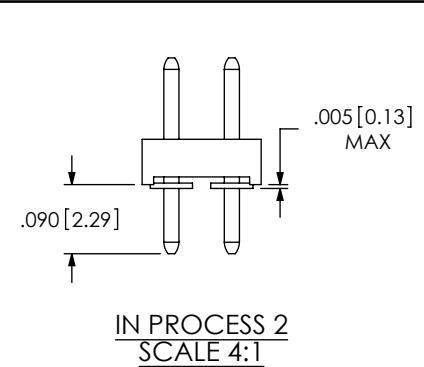
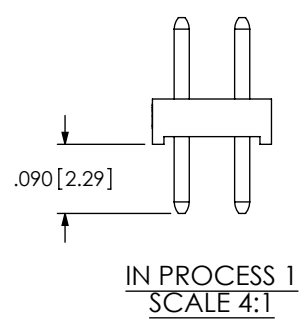
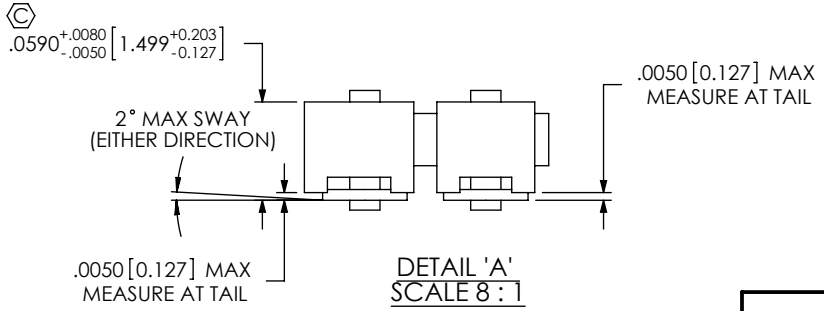
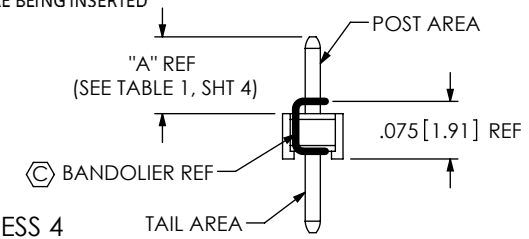

TABLE 3 (-T PLATING ONLY)

LEAD STYLE	MAX NUMBER OF BAND MARKS ALLOWED IN THE POST AREA			
	PIN A	PIN B	PIN C	PIN D
-02	1	1	1	1
-03	2	2	2	2
-04	2	2	2	2
-05	2	2	2	2
-06	2	2	2	2
-07	2	2	2	2
-08	2	2	2	2
-09	2	2	2	2
-10	2	2	2	2
-11	2	2	2	2
-12	2	2	2	2
*-13	2	2	2	2
*-14	2	2	2	2
-15	2	2	2	2

* = PINS TO BE FLIPPED OPPOSITE OF SELECTIVE PLATING BEFORE BEING INSERTED



PROPRIETARY NOTE
 THIS DOCUMENT CONTAINS INFORMATION CONFIDENTIAL AND PROPRIETARY TO SAMTEC, INC. AND SHALL NOT BE REPRODUCED OR TRANSFERRED TO OTHER DOCUMENTS OR DISCLOSED TO OTHERS OR USED FOR ANY PURPOSE OTHER THAN THAT WHICH IT WAS OBTAINED WITHOUT THE EXPRESSED WRITTEN CONSENT OF SAMTEC, INC.

DO NOT SCALE DRAWING
 SHEET SCALE: 3:1



DESCRIPTION: **2MM TERMINAL STRIP ASSEMBLY**

DWG. NO. **MTMM-1XX-XX-XX-X-XXX-XX-XXX**

BY: REIDINGER 12/01/1993 SHEET 2 OF 2

X-ON Electronics

Largest Supplier of Electrical and Electronic Components

Click to view similar products for [samtec](#) manufacturer:

Other Similar products are found below :

[MTMM-105-09-H-D-390](#) [YTW-20-07-H-6-520-110](#) [TW-10-08-H-D-616-107](#) [TW-15-08-H-D-600-080](#) [TW-30-08-H-D-616-107](#) [MTMM-108-05-H-D-220](#) [MTMM-120-06-H-D-180](#) [MTMM-103-05-H-D-220](#) [SSM-105-H-DV-A-P-TR](#) [ERCD-060-19.00-TEU-TBL-1-3](#) [SSQ-108-01-SM-S](#) [SSQ-105-01-SM-S](#) [ACD-185680-02](#) [ESQT-112-02-F-D-375](#) [ESQT-135-03-F-D-380](#) [FTSH-111-01-L-DV](#) [QTE-060-01-L-D-A](#) [MSAS-179-ZUGG-18](#) [MTMM-103-05-H-D-300](#) [MTMM-142-05-H-D-126](#) [MTSW-103-07-F-S-240](#) [MTSW-125-24-H-D-285](#) [ERF8-020-05.0-S-DV-K-TR](#) [IDMD-10-T-12.00-A-G-R](#) [IPL1-112-01-L-D-K](#) [IPL1-116-01-H-D](#) [SFM-107-02-S-D-LC](#) [SFML-115-01-S-D](#) [SFML-125-01-S-D](#) [SFSDT-15-28-H-04.50-DR-NDS](#) [LSHM-120-02.5-L-DV-A-N-K-TR](#) [SMS-125-02-S-D](#) [ESQ-110-14-G-D](#) [ESQT-125-03-F-D-310](#) [ESQT-133-03-F-D-350](#) [SO-0515-01-01-02](#) [SQW-120-01-F-D-VS-A](#) [SSW-110-02-H-D](#) [FJH-50-D-12.00-4](#) [CES-150-01-T-D](#) [QFS-052-01-SL-D-RA](#) [QTE-040-04-L-D-A](#) [QTH-020-04-F-D-DP-A-K-TR](#) [QTH-060-01-F-D-A](#) [QTH-090-04-L-D-A](#) [TCSD-10-S-05.00-01-F-N](#) [TFM-110-02-S-D](#) [TFM-115-02-L-DH](#) [TFM-120-12-S-D-LC](#) [TFML-140-02-S-D](#)