

Amphenol SV MICROWAVE®

RF Connectors & Components

MIL-DTL-39030 Terminations



SV Microwave is a leading qualified source for MIL-PRF-39030 Terminations including:

MIL-DTL-39030/3

MIL-DTL-39030/5

MIL-DTL-39030/7

MIL-DTL-39030/20

MIL-DTL-39030/21

SMA Terminations

TNC Terminations

BNC Terminations

Stripline Terminations (Low Power)

Stripline Terminations (Medium Power)

MIL-DTL-39030/3 SMA Terminations

SV Microwave offers military SMA terminations that are 39030 approved. QPL-39030 parts are designed and made under DSCC qualifications in order to resist harsh environments within military applications.

SMA terminations operate under low power and frequency range up to 19 GHz. These terminations are used in military applications due to their high performance, compact size, and outstanding mechanical durability. Built in accordance with MIL-PRF-39030, SMA terminations can be mated with all connectors that meet these spec mating diameters regardless of manufacturer.

Features & Benefits

- Broadband performance up to 19 GHz
- Nominal impedance up to 95 Ohms
- Terminations in accordance with MIL-DTL-39030

Applications

- Military Systems
- Test and Instrumentation
- Base Stations
- Telecom

To more easily illustrate the ordering procedure for SV Microwave QPL Attenuators, part number **M39030/3-08S** is shown below.

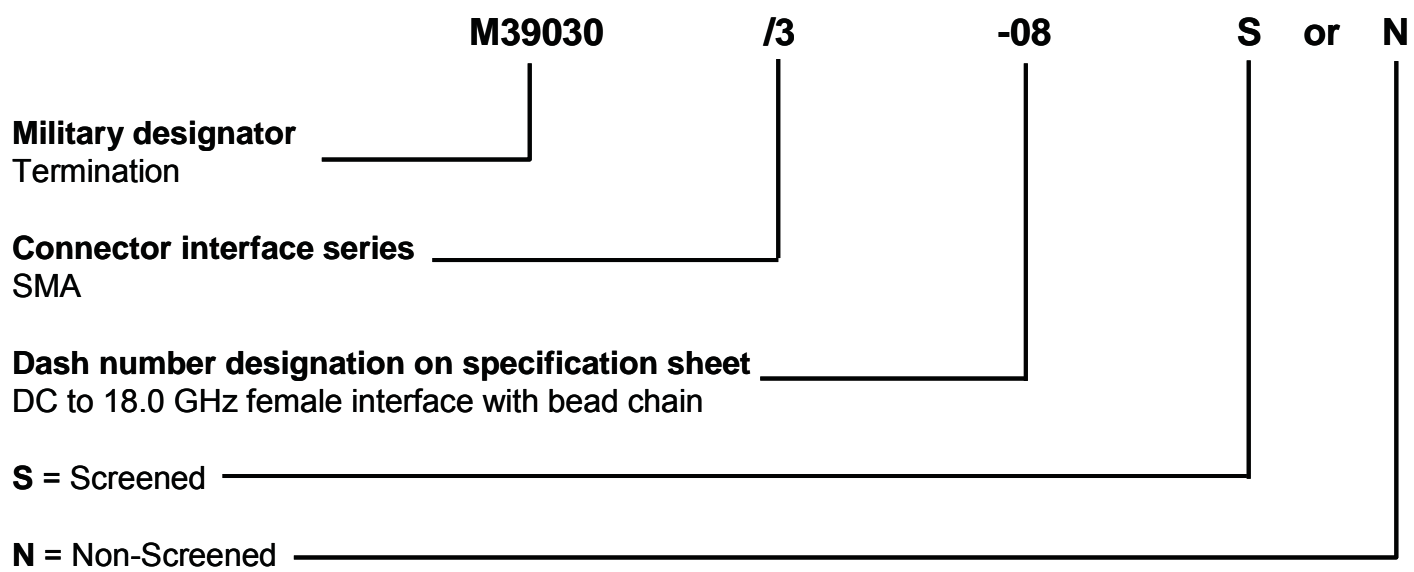

MIL-DTL-39030/3 SMA Dash numbers and characteristics

Dash number N and S	Operating frequency (GHz)	VSWR (max)	Power handling capability (max)		Nominal characteristic impedance (ohms)	Sex	Bead chain	Lock wire holes	Finish
			Average (watts)	Peak (watts)					
01, 16	DC to 18	(1.05 +.010f):1	.5	50	50	M			Gold
02, 17	DC to 18	(1.05 +.010f):1	.5	50	50	M			Passivated
03, 18	DC to 18	(1.05 +.010f):1	.5	50	50	M	✓		Gold
04, 19	DC to 18	(1.05 +.010f):1	.5	50	50	M	✓		Passivated
05	DC to 18	(1.05 +.010f):1	.5	50	50	F			Gold
06	DC to 18	(1.05 +.010f):1	.5	50	50	F			Passivated
07	DC to 18	(1.05 +.010f):1	.5	50	50	F	✓		Gold
08	DC to 18	(1.05 +.010f):1	.5	50	50	F	✓		Passivated
09, 20	DC to 10	1.10:1	1.0	100	50	M		✓	Gold
10, 21	DC to 10	2.10:1	2.0	200	95	M		✓	Gold
11, 22	DC to 18	1.15:1	1.0	100	50	M			Gold
12, 23	2 to 19	1.30:1	1.0	100	50	M		✓	Gold
13, 24	2 to 19	1.30:1	.5	50	50	M	✓	✓	Gold
14, 25	2 to 19	1.30:1	1.0	100	75	M		✓	Gold
15, 26	4.4 to 5.0	(1.025 +.005f):1	.5	50	50	M			Gold

Specifications

Material

Body and connector	Corrosion-resistant steel per SAE-AMS-QQ-S-763 or ASTM A484/A484M and ASTM A582
Contact pin and socket	Beryllium copper per ASTM B194, ASTM B196, or ASTM B197
Bead chain and lug	Corrosion-resistant steel or plastic

Finish

Body and connector	Gold plated per ASTM B488, type 3, grade C, class 1.27 or Passivated per ASTM A967 or SAE-AMS-QQ-P-35
Contact pin and socket	ASTM B488, type II, code C, class 1.27, Nickel per SAE-AMS-QQ-N-290, class I

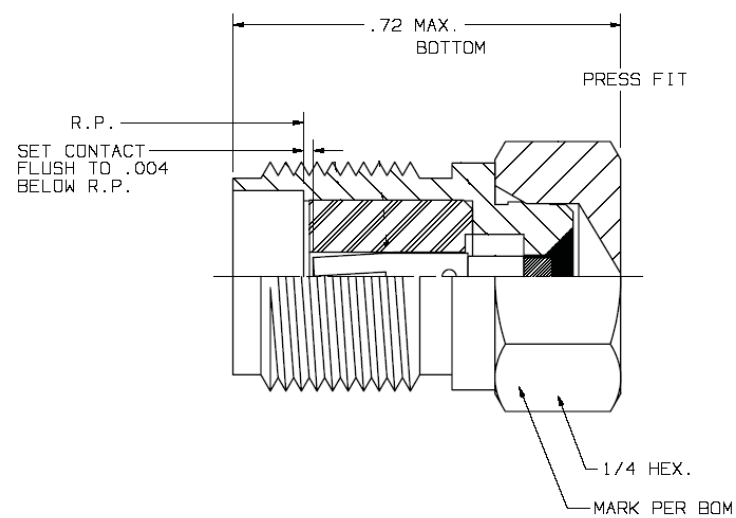
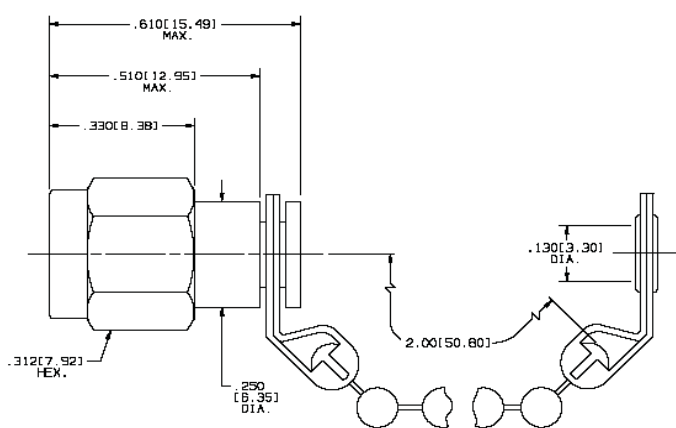

MIL-DTL-39030/5 TNC Terminations

SV Microwave manufactures TNC terminations in accordance with MIL-DTL-39030. Military qualified TNC terminations are rated up to 5 watts average power, constant impedance of 75 Ohms and operate from 0.3 to 12.4 GHz. TNC terminations feature a threaded coupling that offers extra mating stability.

Features & Benefits

- Frequency range .03 to 12.4 GHz
- Nominal impedance 50 and 75 Ohms
- Terminations in accordance with MIL-DTL-39030

Applications

- Antennas
- Cellular
- Mil-Aero
- Telecom
- Base Stations
- Components
- Networks
- Cable Assembly
- Instrumentation
- Radar

To more easily illustrate the ordering procedure for SV Microwave QPL Attenuators, part number **M39030/5-03N** is shown below.

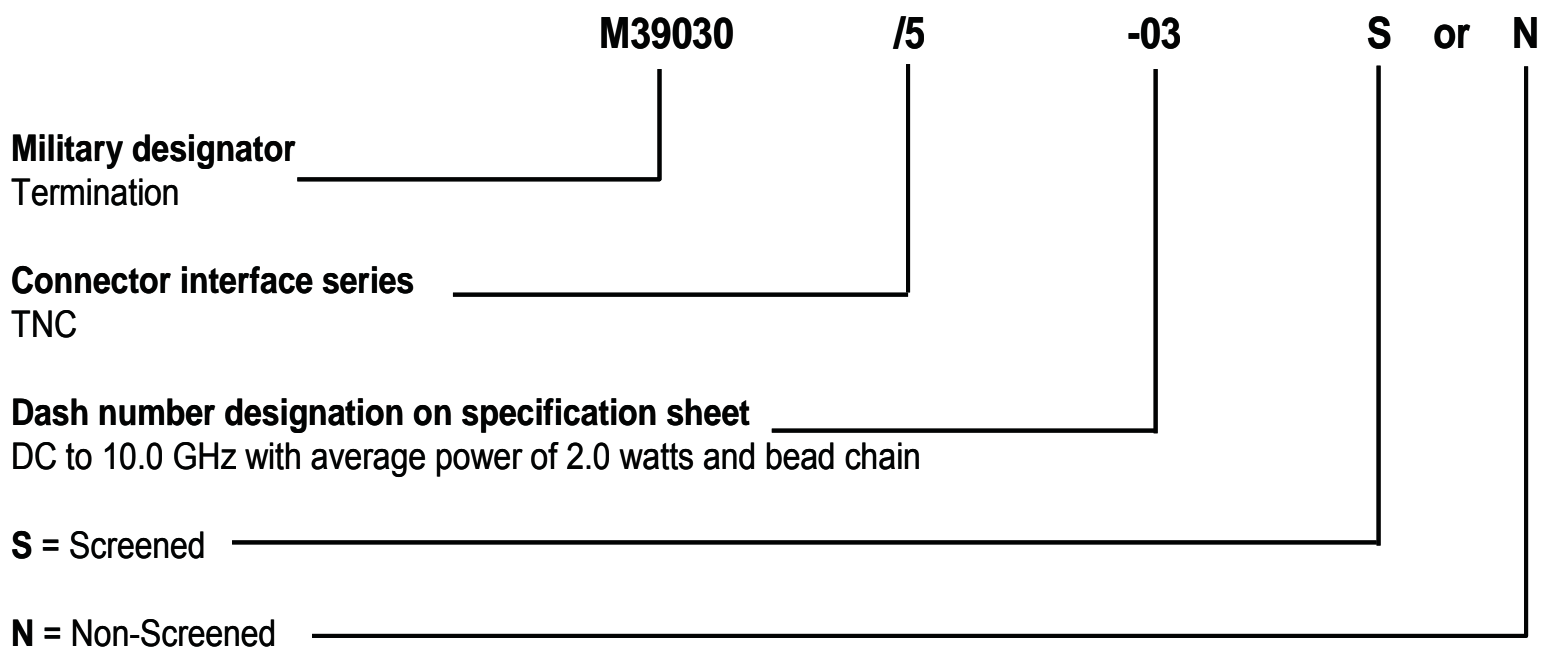

MIL-DTL-39030/5 TNC Dash numbers and characteristics

Dash number N and S	Operating frequency (GHz)	VSWR (max)	Power handling capability (max)		Nominal characteristics Impedance (ohms)	Sex	Bead chain
			Average (watts)	Peak (watts)			
01	DC to 10.0	1.40:1	5.0	3.5K	50	Male	
02	.06 to .08	1.12:1	.5	.6K	75	Male	
03	DC to 10.0	1.15:1	2.0	2.5K	50	Male	✓
04	DC to 10.0	1.05:1 (DC to 2.4 GHz) 1.20:1 (2.4 to 10.0 GHz)	5.0	3.5K	50	Male	
05	DC to 11.0	1.10:1	3.0	1K	51	Male	✓
06	.03 to 12.4	1.15:1	1.0	1.2K	50	Male	
07	.03 to 12.4	1.15:1	1.0	1.2K	50	Female	

Specifications

Material

Body and connector	Corrosion-resistant steel per SAE-AMS-QQ-S-763 or ASTM A484/A484M and ASTM A582
Contact pin and socket	Beryllium copper per ASTM B194, ASTM B196, or ASTM B197/B197M
Bead chain and lug	Corrosion-resistant steel or plastic

Finish

Body and connector	Gold plated per ASTM B488, type 3 class 1.27 or Nickel plated per with SAE-AMS-QQ-N-290, class 1 or Passivated per ASTM-A967 or SAE-AMS2700
Contact pin and socket	Gold plated ASTM B488, type II, code C, class 1.27 Nickel per SAE-AMS-QQ-N-290, class 1

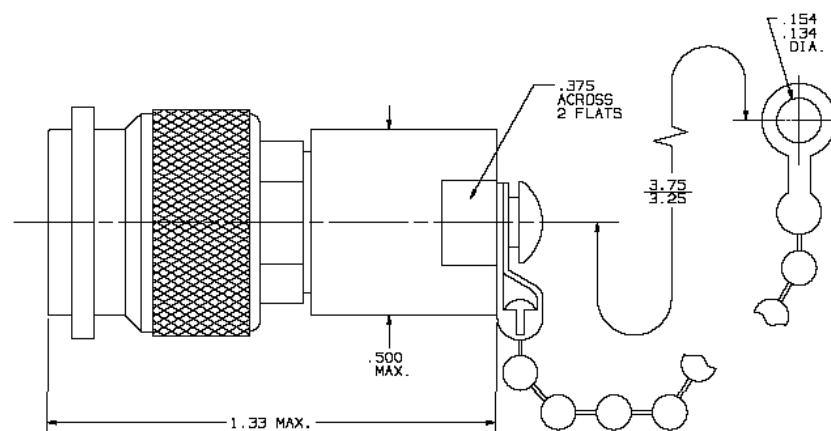

MIL-DTL-39030/7 BNC Terminations

SV Microwave is the only qualified source for terminations in accordance with MIL-DTL-39030/7. Our military qualified BNC terminations are lightweight and designed to operate at DC to 2.5 GHz with nominal impedance of 50 - 600 Ohm. BNC terminations feature a bayonet coupling mechanism for quick mating and unmating. These terminations can accommodate a large variety of RG type and industry standard cables.

Features & Benefits

- Quick mating/unmating bayonet coupling mechanism
- Durable and light weight
- 50 - 600 Ohm Nominal Impedance

Applications

- Military Systems
- Radio Communications
- Antennas
- Base Stations
- Telecom
- Medical equipment
- Test and Instrumentation

To more easily illustrate the ordering procedure for SV Microwave QPL Attenuators, part number **M39030/7-04N** is shown below.

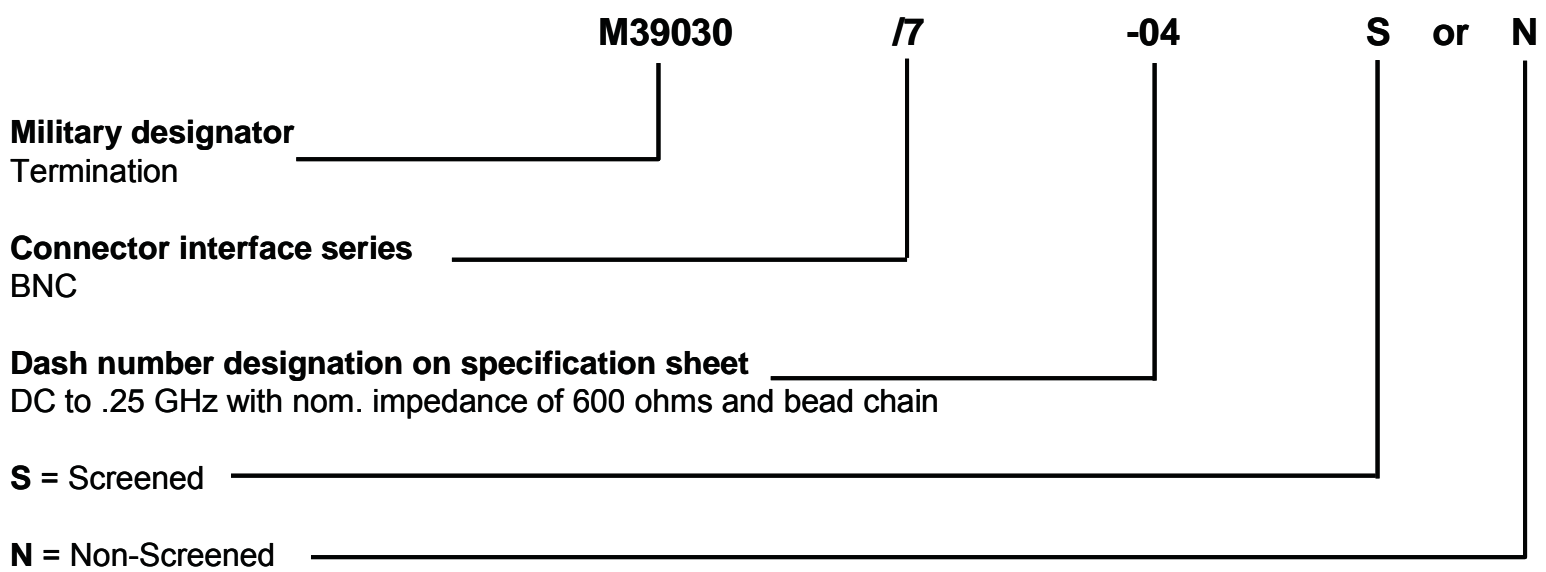

MIL-DTL-39030/7 BNC Dash numbers and characteristics

Dash number	Operating frequency (GHz)	VSWR (max)	Power handling capability (max)		Nominal characteristic impedance (ohms)	Sex	Bead chain
			Average (watts)	Peak (watts)			
01	DC to .25	1.10:1	.5	1.0K	75	Male	✓
02	DC to .25	1.10:1	.5	1.0K	93	Male	✓
03	DC to .25	1.10:1	.5	1.0K	100	Male	✓
04	DC to .25	1.10:1	.5	1.0K	600	Male	✓
05	DC to 2.5	1.15:1	2.0	1.0K	50	Male	
06	DC to 2.5	1.15:1	2.0	1.0K	50	Female	

Specifications

Material

Body and connector

Corrosion-resistant steel per SAE-AMS-QQ-S-763 (dash numbers 01 thru 04)
Brass per ASTM B121, ASTM B36, ASTM B16, ASTM B16M and ASTM B124 (dash numbers 05 and 06)

Contact pin and socket

Beryllium copper per ASTM B196, ASTM B197, or ASTM B194

Bead chain and lug

Corrosion-resistant steel or plastic

Finish

Body, connector, contact pin and socket

Gold plated per ASTM B488, type 3 class 1.27 or Nickel plated per with SAE-AMS-QQ-N-290, class 1

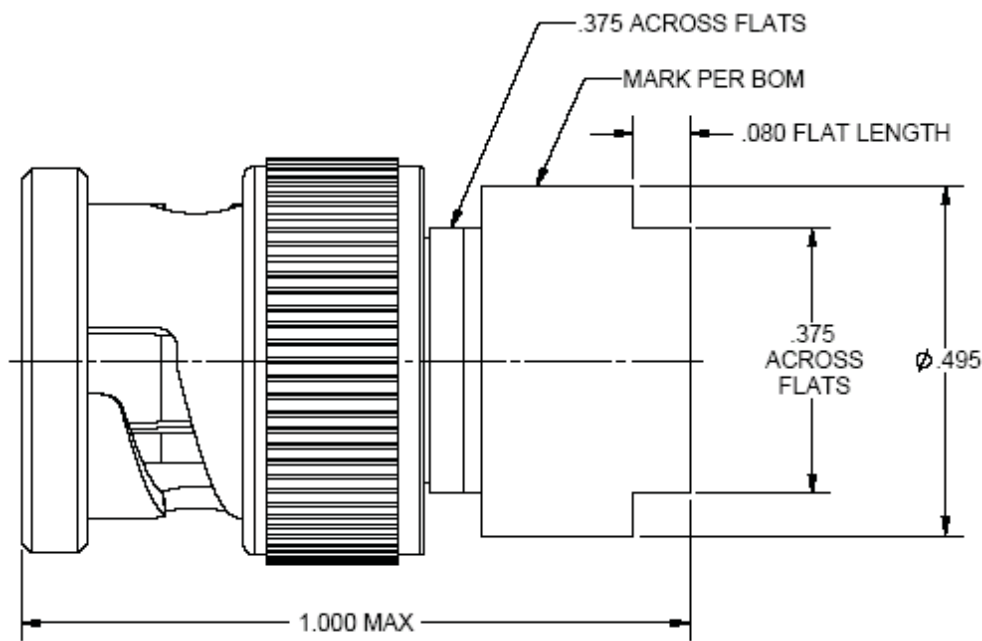

SV Microwave Inspection Capabilities IAW MIL-DTL-39030

SV Microwave possesses the capability not only to manufacture military connectors that meet the DSCC specifications, but also to test and certify them. With extensive in-house testing capabilities, we ensure that when our products are placed in military environments, they will be able to support crucial airborne and terrestrial applications. In-house testing capabilities include MIL-DTL-39030 screening and material inspection.

SV Microwave offers innovative solutions to satisfy your requirements. We have invested in a talented engineering staff, supported by state-of-the-art, high-frequency 3D RF simulation design software. Our full service laboratories perform comprehensive environmental mechanical and electrical testing. We control virtually all processes with in-house machining, fabrication, assembly and acceptance and qualification testing. Using our in-house testing capabilities eliminates the need for outsourcing environmental test requirements, which results in a lower delivered cost and shorter lead-time.

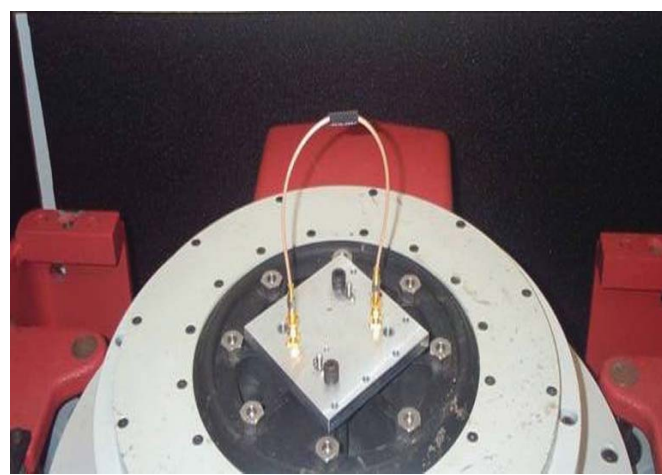

- Visual and mechanical inspection and weight
- Force to engage/disengage
- Coupling proof torque
- Connector durability
- Solderability
- Terminal strength
- VSWR
- Thermal shock

- Vibration
- Shock
- Moisture resistance
- Salt Spray
- Power dissipation
- Endurance
- Overload
- Pressurization
- Barometric pressure

X-ON Electronics

Largest Supplier of Electrical and Electronic Components

Click to view similar products for [RF Connectors / Coaxial Connectors](#) category:

Click to view products by [SV Microwave](#) manufacturer:

Other Similar products are found below :

[R125315120](#) [8915-1511-000](#) [89674-0827](#) [5916-1103-603](#) [0106-001-000](#) [6-0001-3](#) [6001-7071-019](#) [6002-7051-003](#) [6002-7551-202](#) [6059674-1](#) [619550-1](#) [630059-000](#) [M39012/25-0021](#) [M39012/79-3008](#) [M39030/3-01N](#) [M39030/3-03N](#) [M3933/25-29N](#) [M3933/25-36N](#) [6500-7071-046](#) [6501-1071-002](#) [M83723/72W24576](#) [M83723/72W2457N](#) [6769](#) [CX050L2AQ](#) [7002-1541-010](#) [7003-1572-002](#) [7004-1512-000](#) [7009-1511-004](#) [7010-1511-000](#) [7029-1511-060](#) [7101-1541-010](#) [7101-1571-002](#) [7105-1521-002](#) [7145-1521-002](#) [7209-1511-011](#) [7210-1511-012](#) [7210-1511-015](#) [7210-1511-019](#) [7210-1511-040](#) [7225-1512-050](#) [7242-1511-000](#) [73137-5015](#) [73251-0111](#) [73251-0672](#) [73276-1501](#) [73366-0013](#) [73404-2300](#) [73413-6080](#) [734151610](#) [73415-5721](#)