

fischer

elektronik

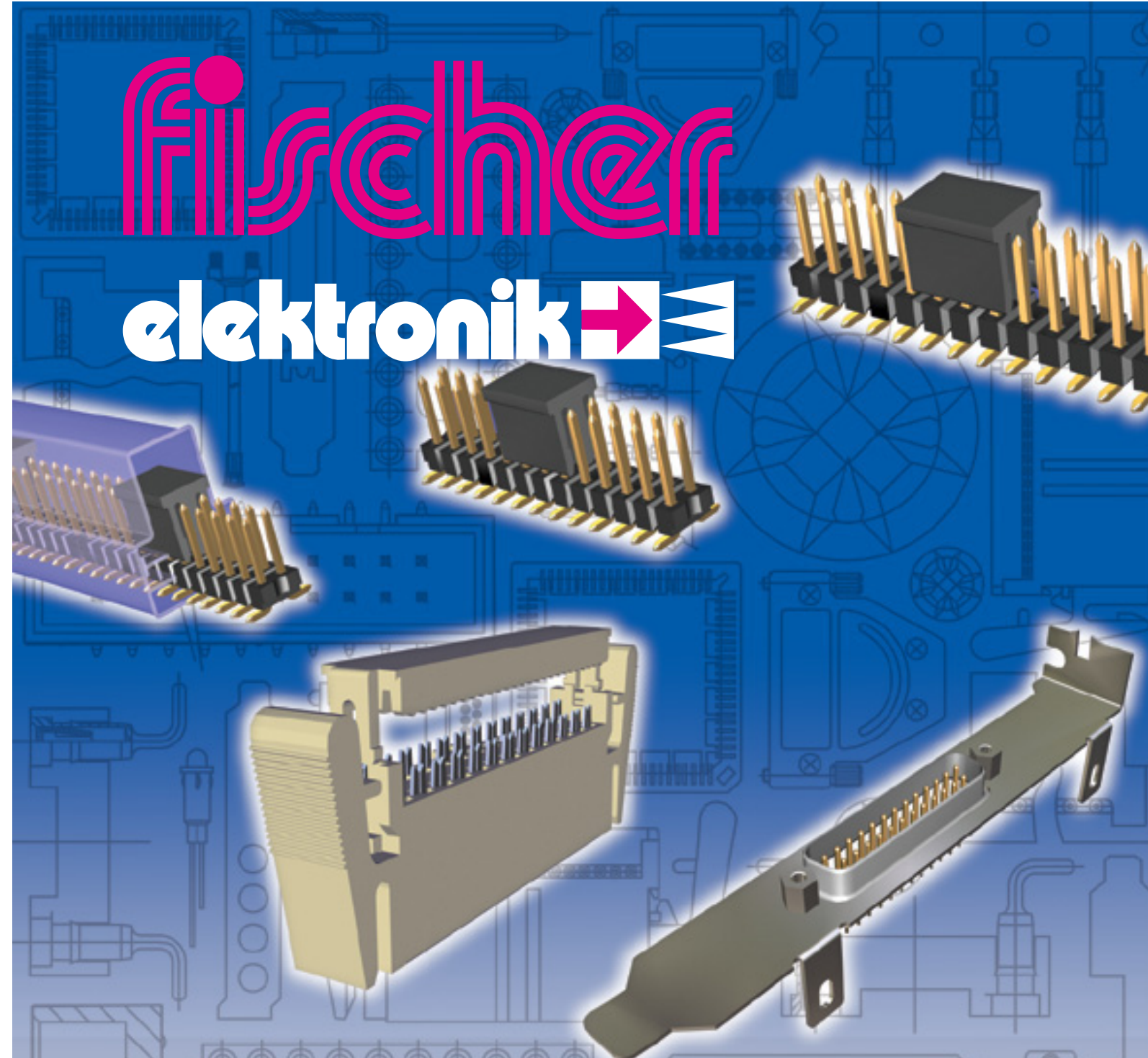

f.con.e

TÜV
ISO 14001

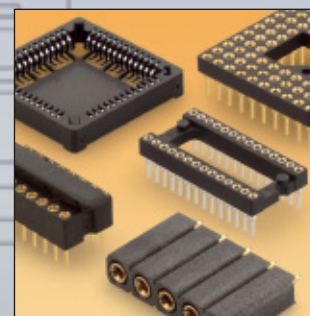

TÜV
CERT
ISO 9001

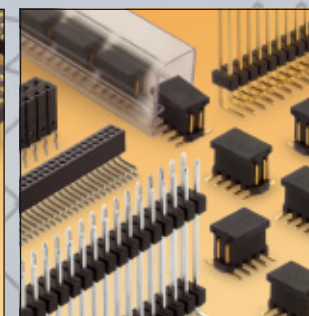

Sockets

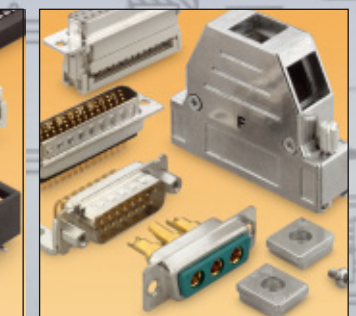
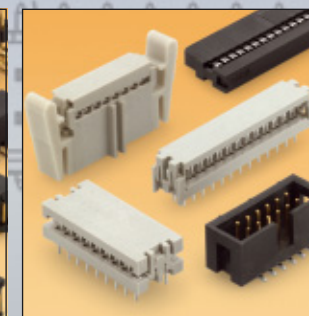

Connectors



Brackets



The information given in this catalogue were established and examined carefully. Nevertheless, mistakes or printing errors, and especially technical modifications and updating and improvement of our products, cannot be excluded. All trade marks are recognised even if they are not specifically identified or mentioned. No identification does not imply that a product or trademark is not registered. No part of this catalogue may be reproduced or distributed without prior written consent of Fischer Elektronik. All data contained in this catalogue, in texts, illustrations, documents and descriptions are subject to copyright and the provisions of DIN ISO 16016. All rights reserved.

© Copyright Fischer Elektronik 1969 ...

Fischer Elektronik GmbH & Co. KG







P.O. Box 1590
D-58465 Lüdenscheid



House address







Nottebohmstr. 28
D-58511 Lüdenscheid
Fon: +49 (0) 23 51 4 35-0
Fax: sales +49 (0) 23 51 4 57 54
purchasing +49 (0) 23 51 45 94 33
exports +49 (0) 23 51 43 51 85
info@fischerelektronik.de
www.fischerelektronik.de

Fischer Elektronik Österreich GmbH

Hirschstettnerstraße 19-21/K
A-1220 Wien
Fon: +43 (0) 1 8 76 62 27
Fax: +43 (0) 1 8 76 62 27-11
online@fischerelektronik.co.at
www.fischerelektronik.at

art. no.	HEATSINKS & CASES SURFACES	
AL		raw degreased aluminium
BZ		raw pickled aluminium
LP		outside black lacquered RAL 9005/transparent passivated
ME		clear anodised
MI		solderable surface
SA		black anodised
TP		chrome-free transparent passivated

art. no.	CONNECTOR CONTACT SURFACE FINISH	
G		gold-coated
S		selective gold plating
Z		tinned

art. no.	RAL	COLOURS	ARTICLES
GO	6026	 opal green	19" system cases RackCase/shell cases
K	7032	 gravel grey	bench cases
LG	7035	 light grey	shell cases
NB	5022	 night blue	19" system cases RackCase/shell cases
S	9005	 deep black	bench cases/shell cases/19" system cases RackCase
TB	5018	 turquoise blue	19" system cases RackCase/shell cases
UL	5002	 ultramarine blue	Plusline/shell cases

Alphanumerical product list

art. no.	page	art. no.	page	art. no.	page	art. no.	page
1706 ... G	F 2	CAB 4 ...	G 77	DIL ... N ...	F 4	KT	I 20
1831 ...	F 2	CAB 5 ...	G 77	DIL ... O ...	F 5	KT SV	I 23
ASL ... SMD ...	H 7	CAB 6 ...	G 77	DIL ... OR ...	F 12	LB ... G	F 24
ASL ... SMD ... B SM	H 7	CAB 9 ...	G 77	DIL ... P ...	F 5	LB SL ...	G 20
ASLA ...	H 6	CB ...	F 24	DIL ... PEK	F 10	LB SLY 06 ...	G 20
ASLG ...	H 6	D W 9 37	H 11	DIL ... Q ...	F 6	LEB ... G	F 24
BADM ...	I 27	KK W		DIL ... SMD M	F 16	LL 30 HRP	L 9
BADP ...	I 27	PV W		DIL ... SMD PK3	F 15	LL 30 HRS	L 9
BK 01 32	H 11	PVY W		DIL ... SMD SK5	F 15	LL 30 PRB ...	L 11
BL 1 ...	G 27	SB W		DIL ... U ...	F 6	LL 30 PRL ...	L 11
BL 10 ...	G 33	DB ... L	I 3	DIL ... V ...	F 7	LL 30 VRFS ...	L 11
BL 11 ...	G 29	DB ... LA	I 4	DIL ... W ...	F 7	LL 30 WRFP ...	L 10
BL 12 ...	G 29	DB ... P	I 18	DIL ... W 90	F 12	LL 35 HVS	L 9
BL 13 ...	G 33	DB ... SMD TR	I 17	DIL ... X ...	F 9	LL 60 WRB 254	L 10
BL 14 ...	G 33	DB ... T	I 3	DIL ... Y ...	F 10	MAH ...	L 2
BL 15 SMD ...	G 46	DB ... WW 3	I 4	DIL SMD ...	F 16	MAH 3 ...	L 2
BL 16 SMD ...	G 46	DB BK 09 ... /	I 11	DIL SMD M ...	F 16	MAH 4 ...	L 2
BL 17 SMD ...	G 47	DB BK 15 ... /		DILS ... 6 PK 3 /	F 13	MAH 5 ...	L 3
BL 18 ...	G 34	DB BK 25 ... /		DILS ... 6 PK 5		MELA ...	G 2
BL 19 ...	G 34	DB BK 37 ...		DILS ... GA LO /	F 14	MIC ...	F 14
BL 2 ...	G 27	DB BK 50 ...	I 11	DILS ... GB LO		MK 01 ...	G 21
BL 20 SMD ...	G 47	DB BK LP 09 ... /	I 12	DILS ... GO	F 13	MK 02 ...	G 3
BL 21 ...	G 30	DB BK LP 25 ... /		DILS ... PK 3 /	F 13	MK 03 ...	G 3
BL 3 ...	G 27	DB BK LP 37 ...		DILS ... PK 5		MK 04 ...	G 3
BL 4 ...	G 27	DS WK ... / DB WK ...	I 5	DLH 21 ...	L 8	MK 05 ...	G 3
BL 5 ...	G 31	DB ... P	I 19	DS ... L	I 2	MK 06 ...	G 22
BL 6 ...	G 31	DBM 13K3 L20	I 14	DS ... LA	I 3	MK 07 ...	G 22
BL 7 ...	G 31	DBM 3K3 L20	I 14	DS ... P	I 16	MK 08 ...	G 4
BL 8 ...	G 31	DBM 7K2 L20	I 14	DS ... SMD TR	I 15	MK 10 ...	G 4
BL 9 ...	G 33	DDH 3 E	L 6	DS ... T	I 2	MK 11 ...	G 4
BL KG 3 ...	G 31	DDH 3 L	L 6	DS ... WW 3	I 2	MK 12 X 2 ...	G 21
BL LP 1 ...	G 28	DDH 3 M	L 6	DS BK 09 ... /	I 11	MK 13 X ...	G 21
BL LP 2 ...	G 28	DDH 3 R	L 6	DS BK 15 ... /		MK 14 X ...	G 5
BL LP 3 ...	G 28	DDH 5 E	L 7	DS BK 25 ... /		MK 15 ...	G 5
BL LP 4 ...	G 28	DDH 5 L	L 7	DS BK 37 ...		MK 17 ...	G 21
BL LP 5 SMD ...	G 43	DDH 5 M	L 7	DS BK 50	I 11	MK 201 ...	G 21
BL LP 6 SMD ...	G 45	DDH 5 R	L 7	DS BK LP 09 ... /	I 12	MK 202 ...	G 3
BLM 1 SMD ...	G 74	DF 1 MK 9 Z	G 54	DS BK LP 15 ... /		MK 203 ...	G 3
BLM 2 SMD ...	G 74	DF 1 OK 9 Z	G 54	DS BK LP 25 ... /		MK 204 ...	G 3
BLM KG 1 ... /	G 70	DF 2 MK 9 Z	G 54	DS BK LP 37 ...		MK 205 ...	G 3
BLM LG 1 ...		DF 2 OK 9 Z	G 54	DS WE 3 ... / DS WE 4 ... /	I 6	MK 207 ...	G 22
BLM KG 2 ... /	G 70	DF OB ...	G 55	DB WE 3 ... / DB WE 4 ...		MK 208 ...	G 4
BLM LG 2 ...		DH ... K / DH ... KM	I 24	DS WMV 4 ... /	I 5	MK 21 ...	G 32
BLM LA 1 ...	G 70	DH ... S / DH ... M	I 20	DB WMV 4 ...		MK 210 ...	G 4
BLP 1 ...	G 53	DH ... VM	I 26	DS WP ...	I 19	MK 211 ...	G 4
BLP 2 ...	G 53	DH 09 S / DH 09 M	I 20	DS WR ... / DB WR ...	I 6	MK 212 X 2 ...	G 21
BLR 1 ...	G 72	DH 3 R	L 5	DS WR 3 ... / DS WR 4 ...	I 6	MK 213 X ...	G 21
BLR 2 ...	G 72	DH 3 V	L 4	DB WR 3 ... / DB WR 4		MK 214 X ...	G 5
BLR 3 ...	G 72	DH 3 W	L 5	DSM 13K3 L20	I 13	MK 217 ...	G 21
BLR 4 ...	G 72	DH 5 R	L 5	DSM 3K3 L20	I 13	MK 22 SMD ...	G 47
BLR 5 SMD ...	G 76	DH 5 SRC	L 4	DSM 7K2 L20	I 13	MK 220 SMD ...	G 49
BLR 6 SMD ...	G 76	DH 5 VC	L 4	FD A ...	I 9	MK 221 ...	G 32
BLR 7 SMD ...	G 76	DH 5 W	L 5	FD B ... T ...	I 10	MK 222 SMD ...	G 47
BLY 1 ...	G 60	DH BK ... K / DH BK ...	I 25	FD S ... LA ...	I 10	MK 223 SMD ...	G 49
BLY 2 ...	G 60	KM		FLMP ...	H 5	MK 226 SMD ...	G 35
BLY 3 ...	G 60	DH SG ...	I 21	FV ...	H 3	MK 228 THR ...	G 23
BLY 4 ...	G 60	DH SV ... S	I 22	HD B ... L	I 7	MK 23 SMD ...	G 49
BLY 5 SMD ...	G 64	DIL ... 06 E ...	F 11	HD B ... T	I 8	MK 24 SMD ...	G 47
BLY 6 SMD ...	G 64	DIL ... 06 E ...	F 11	HD S ... L	I 7	MK 25 SMD ...	G 49
BLY 8 SMD ...	G 64	DIL ... A ...	F 8	HD S ... T	I 8	MK 251 ...	G 5
CAB 10 G S	G 78	DIL ... B ...	F 9	HFD ...	I 29	MK 26 SMD ...	G 35
CAB 11 G S	G 78	DIL ... D ...	F 9	HFK S ... / HFK B ...	I 29	MK 27 SMD ...	G 35
CAB 14 G S	G 78	DIL ... E ...	F 8	ISQ ...	F 29	MK 51 ...	G 5
CAB 15 G S	G 78	DIL ... G ...	F 12	KHPC 9 polig	K 23	MK LP 18 ...	G 24
CAB 3 ... 03 Z	F 23	DIL ... H ...	F 8	KK ... Z	H 2	MK LP 19 ...	G 24
CAB 3 SMD ...	F 23	DIL ... M ...	F 4	KKS 050	I 26	MK LP 218 ...	G 24

Alphanumerical product list

art. no.	page	art. no.	page	art. no.	page
MK LP 219 ...	G 24	SL 1 ... / SL 11 ...	G 8	TF 54	F 21
MK LP 240 ...	G 6	SL 10 SMD ...	G 37	TF 56	F 21
MK LP 241 ...	G 6	SL 11 SMD ...	G 37	TF 58	F 21
MK LP 242 ...	G 6	SL 12 SMD ...	G 39	TF G	F 2
MK LP 40 ...	G 6	SL 13 ...	G 15	V	I 28
MK LP 41 ...	G 6	SL 14 ...	G 15	V 2	I 28
MK LP 42 ...	G 6	SL 15 SMD ...	G 42	VBK 1	H 11
MK LP 43 ...	G 6	SL 16 SMD ...	G 44	VFL ...	H 5
PCI 9 polig	K 7	SL 17 SMD ...	G 39	VG 2	I 28
PEK G	F 2	SL 18 ...	G 11	WWPS 1 G	F 2
PF 510 ...	F 20	SL 19 ...	G 11		
PF 53 ...	F 19	SL 2 ... / SL 22 ...	G 8		
PF 54 ...	F 19	SL 20 THR ...	G 9		
PF 58 2 ...	F 19	SL 21 THR ...	G 9		
PF 58 23 ...	F 19	SL 3 ... / SLK 3 ...	G 10		
PK 1 ...	F 2	SL 4 ... / SLK 4 ...	G 10		
PK 3 ...	F 3	SL 5 ...	G 14		
PK 4 Z	F 3	SL 6 ...	G 14		
PLCC ...	F 17	SL 7 ...	G 7		
PLCC ... SMD	F 18	SL 8 ...	G 7		
PLCC 32 LP SMD ...	F 18	SL 9 ...	G 7		
PO A ...	G 25	SL KA 3 ...	G 18		
PO B ...	G 25	SL KG 3 ...	G 18		
PQ 18 ...	F 28	SL LP 1 ...	G 12		
PQ 18 W ...	F 28	SL LP 2 ...	G 12		
PSB 03 G	F 24	SL LP 3 ...	G 13		
PV ...	H 4	SL LP 4 ...	G 13		
PVY ...	H 10	SL LP 5 SMD ...	G 40		
QS 25 GS	F 28	SL LP 6 SMD ...	G 40		
RS HH	I 22	SLM N 1 ... / SLM N 11 ...	G 66		
RS SH 3/	I 22	SLP 1 ...	G 51		
RS SH 4		SLP 2 ...	G 51		
RS SH D	I 23	SLR 1 ...	G 71		
SB 1	F 25	SLR 2 ...	G 71		
SB 12	F 26	SLR 3 ...	G 71		
SB 13	F 27	SLR 4 ...	G 71		
SB 15	F 27	SLR 5 SMD ...	G 75		
SB 16	F 27	SLR 6 SMD ...	G 75		
SB 2	F 25	SLR 7 SMD ...	G 75		
SB 3	F 25	SLU ...	G 17		
SB 4	F 25	SLUP 31 ...	G 52		
SB 5	F 26	SLV N 1 ... / SLV N 11 ...	G 69		
SB 6	F 26	SLV W 1 ...	G 67		
SB 9	F 26	SLV W 1 KA ...	G 68		
SBAU ...	H 8	SLV W 1 SMD ...	G 73		
SBAU 1 ...	H 8	SLV W 2 ...	G 67		
SBAU 4 ...	H 9	SLV W 2 KA ...	G 68		
SIL 1 ...	G 26	SLV W 2 SMD ...	G 73		
SIL 1 G / SIL 1 Z	F 2	SLY 1 ...	G 56		
SIL 2 ...	G 26	Sly 10 SMD ...	G 62		
SIL 3 ...	G 26	Sly 2 ...	G 56		
SK 02 ...	F 3	Sly 3 ...	G 57		
SK 03 ...	F 3	Sly 4 ...	G 57		
SK 04 Z	F 3	Sly 5 ...	G 58		
SK 05 ...	F 3	Sly 6 ...	G 58		
SK 06 ...	F 2	Sly 7 SMD ...	G 61		
SK 08 G	F 3	Sly 8 SMD ...	G 61		
SK 11 ...	F 3	Sly 9 SMD ...	G 62		
SK 13 x 2 ...	F 2	SSK B ...	I 30		
SK 14 x 2 ...	F 3	SSK S ...	I 30		
SK 19 ...	F 2	TF 183	F 22		
SK 40 ...	F 3	TF 184	F 22		
SK 41 ...	F 3	TF 3 2 (TO 3)	F 20		
SK 42 ...	F 3	TF 510	F 22		
SKB 5 Z	F 2	TF 512	F 22		
SKB 9 Z	F 2	TF 53	F 21		

Fischer Elektronik GmbH & Co. KG

Postfach 1590 • D-58465 Lüdenscheid

Hausadresse

Nottebohmstr. 28 • D-58511 Lüdenscheid

Telefon: 0 23 51 / 4 35-0

Telefax:

Verkauf

0 23 51 / 4 57 54

Einkauf

0 23 51 / 45 94 33

Export

0 23 51 / 43 51 85

info@fischerelektronik.de

www.fischerelektronik.de

Fischer Elektronik Österreich GmbH

Hirschstettner Straße 19-21/K • A-1220 Wien

Telefon: 01 / 8 76 62 27

Telefax: 01 / 8 76 62 27-11

online@fischerelektronik.co.at

www.fischerelektronik.at

Astrel AG

Churerstrasse 168

CH-8808 Pfäffikon SZ

Telefon: 055 / 415 66 15

Telefax: 055 / 415 66 10

astrel@swissonline.ch

www.astrel.ch

Index

Accessoires for DH SV ...	I 22, 23
Accessories for flat ribbon cable and application tools	H 11
Brackets for PC	K 7, 23
Connector-sleeves	F 25, 26, 27
Connectors in press-fit mounting	G 51, 52, 53
Cut-out cover	I 27
D-Sub connector for flat ribbon cable	I 11, 12
D-Sub connectors High Density	I 7, 8
D-Sub cover for flat cable	I 25
D-Sub filter connector	I 9, 10
D-Sub hoods made of full metal	I 26
D-Sub hoods, compact	I 24
D-Sub hoods, quick-action locking system	I 22
D-Sub hoods, standard	I 16, 19, 20, 21
D-Sub in SMD-mounting	I 15
D-Sub mixed layout connectors	I 13, 14
D-Sub standard connectors	I 2, 3, 4
D-Sub standard connectors with mounting bracket	I 5, 6
Direct female connector	G 54, 55
Dust protection caps	I 30
Female connector	H 3, 4, 5, 10
Female headers in SMD mounting	G 74
Female headers soldering technique	G 27, 28, 29, 30, 70
HF-tight caps, HF-seals	I 29
High precision female header in through-hole-reflow-soldering technique	G 23
High-precision contacts, loose	F 2, 3
High-precision female headers in SMD mounting	G 43, 46, 47, 49, 64, 76
High-precision female headers soldering technique	G 21, 22, 24, 31, 32, 33, 34, 60, 72
High-precision male headers in SMD mounting	G 35, 75
High-precision male headers soldering technique	G 3, 4, 5, 6, 7, 71
High-precision sockets for DIL-IC	F 4, 6, 7, 9, 11, 12, 13, 14, 15, 16
High-precision sockets for DIL-IC, closed frame	F 8, 9, 10
High-precision sockets for DIL-IC, open frame	F 4, 5, 6, 7
IC-mounting tools	F 14
Jumper links	F 24, G 20
Jumpers	G 77, 78
LED-holders for PCB assembly	L 5, 6, 7, 8
LED-holders for front panel assembly	L 4
Light pipes for SMDs	L 9, 10, 11
Male connector	G 2
Male header	H 6, 7
Male header in through-hole-reflow-soldering technique	G 9
Male headers in SMD mounting	G 37, 39, 40, 42, 61, 62, 73
Male headers soldering technique	G 8, 10, 11, 12, 13, 14, 15, 17, 18, 56, 57, 58, 66, 67, 68, 69
Printed circuit connector	H 2, 8, 9
Programmable headers	F 23
Screw-fastening	I 28
Sockets for IC-PLCC	F 17, 18
Sockets for TO ... cases	F 19, 20, 21, 22
Sockets for crystal oscillators	F 28, 29
Spacers and mounting strips for LED	L 2, 3
Terminal strips soldering technique	G 25, 26

Female contacts for Ø 0.5 mm

<p>art. no. 1706 G</p>	<p>art. no. PEK G</p>	<p>art. no. PK 1 G ... Z</p>
<p>art. no. 1831 Z</p>	<p>art. no. WWPS 1 G</p>	<p>art. no. SK 06 G ... Z</p>
<p>art. no. SK 13 X 2 G</p>	<p>art. no. TF G</p>	<p>art. no. SK 19 G ... Z</p>
<p>art. no. SIL 1 G ... Z</p>		

Female contact for 0.64 mm □ and Ø 0.80 mm

<p>art. no. SKB 5 Z</p>	<p>art. no. SKB 9 Z</p>
---	---

contact shell surface: tin-plated
contact spring: gold-plated

Contacts with solder head

<p>art. no. PK 4 Z</p>	<p>art. no. SK 02 G ... Z</p>	<p>art. no. SK 03 G ... Z</p>
<p>art. no. SK 04 Z</p>	<p>art. no. SK 08 G</p>	

Male contacts

<p>art. no. PK 3 G ... Z</p>	<p>art. no. SK 05 G ... Z</p>	<p>art. no. SK 11 G ... Z</p>
<p>art. no. SK 14 X 2 G ... Z</p>	<p>art. no. SK 40 G</p>	<p>art. no. SK 41 G ... Z</p>
<p>art. no. SK 42 G ... Z</p>		

High-precision sockets for DIL-IC, open frame

A

B

C

D

E

F

G

H

I

K

L

M

N

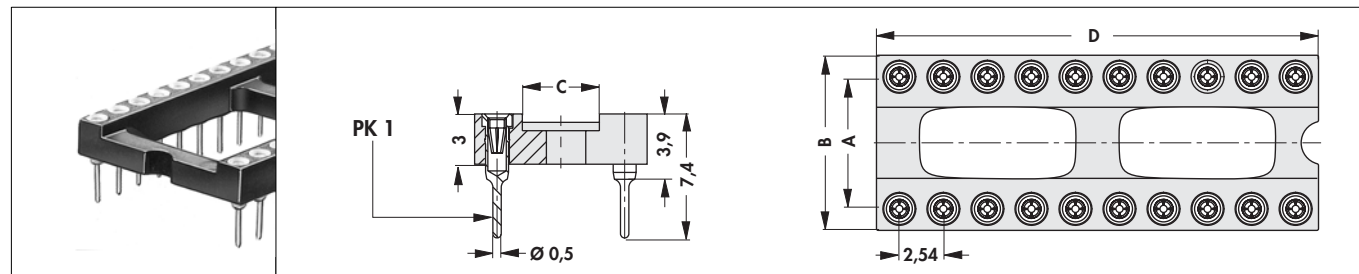

art. no.	no. of contacts	dim. [mm]				art. no.	no. of contacts	dim. [mm]			
		A	B	C	D			A	B	C	D
DIL 6 M ...	6	7.62	10.10	4.10	7.60	DIL 22 03 M Z	22	7.62	10.10	4.10	27.90
DIL 8 M ...	8	7.62	10.10	4.10	10.10	DIL 24 M ...	24	15.24	17.70	11.70	30.60
DIL 10 M ...	10	7.62	10.10	4.10	12.70	DIL 24 03 M ...	24	7.62	10.10	4.10	30.60
DIL 14 M ...	14	7.62	10.10	4.10	17.70	DIL 24 04 M G	24	10.16	12.70	6.70	30.60
DIL 16 M ...	16	7.62	10.10	4.10	20.40	DIL 28 M ...	28	15.24	17.70	11.70	35.70
DIL 18 M ...	18	7.62	10.10	4.10	23.00	DIL 28 03 M ...	28	7.62	10.10	4.10	35.70
DIL 20 M ...	20	7.62	10.10	4.10	25.50	DIL 32 M ...	32	15.24	17.70	11.70	40.60
DIL 22 M ...	22	10.16	12.70	6.70	27.90	DIL 36 M G	36	15.24	17.70	11.70	45.60

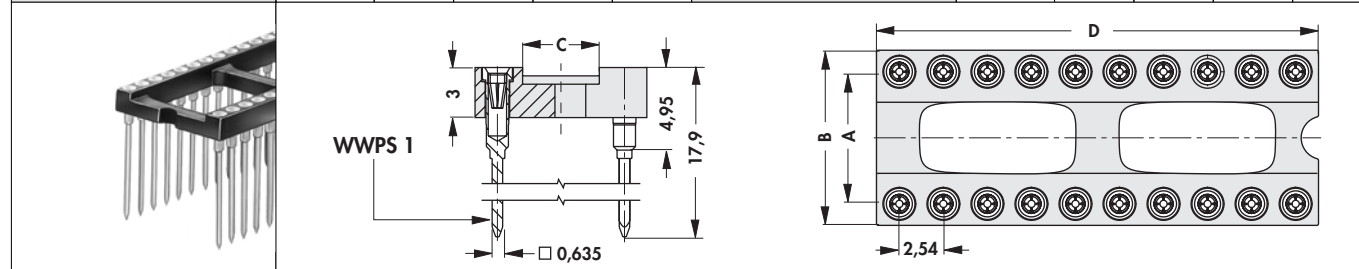

art. no.	no. of contacts	dim. [mm]				art. no.	no. of contacts	dim. [mm]			
		A	B	C	D			A	B	C	D
DIL 6 N ...	6	7.62	10.10	4.10	7.60	DIL 22 03 N ...	22	7.62	10.10	4.10	27.90
DIL 8 N ...	8	7.62	10.10	4.10	10.10	DIL 24 N ...	24	15.24	17.70	11.70	30.60
DIL 10 N ...	10	7.62	10.10	4.10	12.70	DIL 24 03 N Z	24	7.62	10.10	4.10	30.60
DIL 14 N ...	14	7.62	10.10	4.10	17.70	DIL 24 04 N Z	24	10.16	12.70	6.70	30.60
DIL 16 N ...	16	7.62	10.10	4.10	20.40	DIL 28 N G	28	15.24	17.70	11.70	35.70
DIL 18 N Z	18	7.62	10.10	4.10	23.00	DIL 28 03 N Z	28	7.62	10.10	4.10	35.70
DIL 20 N Z	20	7.62	10.10	4.10	25.50	DIL 32 N Z	32	15.24	17.70	11.70	40.60
DIL 22 N ...	22	10.16	12.70	6.70	27.90	DIL 36 N ...	36	15.24	17.70	11.70	45.60

please indicate: ... surface
G=gold-plated
Z=tin-plated

contact spring: gold-plated

Fem. head. 2.54 solder, put through → G 29
 Programmable headers → F 23
 Sockets for LED → F 11 - 12
 Technical data → F 31 - 34

Single precision contacts → F 2 - 3
 High-prec. male headers 2.54 solder → G 21 - 24
 Peel-off terminal strips → G 25

F 4

High-precision sockets for DIL-IC, open frame

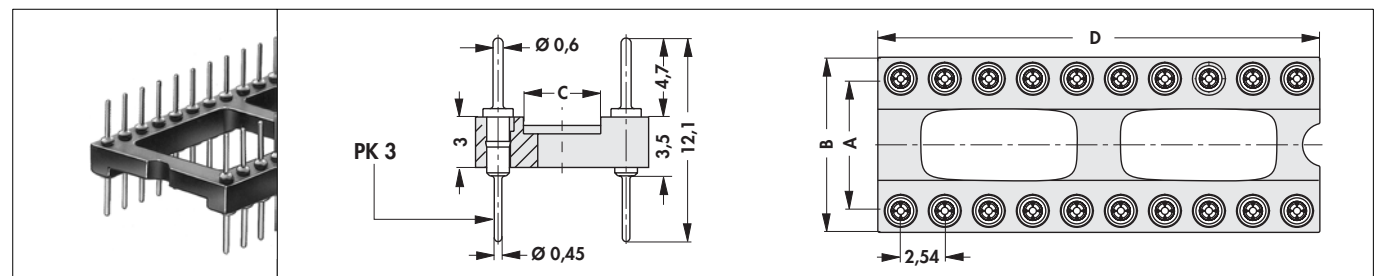

art. no.	no. of contacts	dim. [mm]				art. no.	no. of contacts	dim. [mm]			
		A	B	C	D			A	B	C	D
DIL 6 O ...	6	7.62	10.10	4.10	7.60	DIL 22 03 O Z	22	7.62	10.10	4.10	27.90
DIL 8 O ...	8	7.62	10.10	4.10	10.10	DIL 24 O G	24	15.24	17.70	11.70	30.60
DIL 10 O Z	10	7.62	10.10	4.10	12.70	DIL 24 03 O ...	24	7.62	10.10	4.10	30.60
DIL 14 O ...	14	7.62	10.10	4.10	17.70	DIL 24 04 O Z	24	10.16	12.70	6.70	30.60
DIL 16 O ...	16	7.62	10.10	4.10	20.40	DIL 28 O ...	28	15.24	17.70	11.70	35.70
DIL 18 O ...	18	7.62	10.10	4.10	23.00	DIL 28 03 O Z	28	7.62	10.10	4.10	35.70
DIL 20 O ...	20	7.62	10.10	4.10	25.50	DIL 32 O ...	32	15.24	17.70	11.70	40.60
DIL 22 O ...	22	10.16	12.70	6.70	27.90	DIL 36 O Z	36	15.24	17.70	11.70	45.60

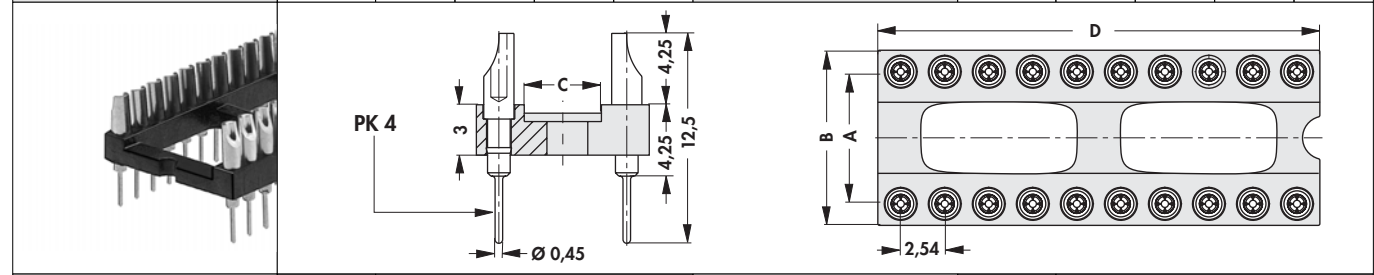

art. no.	no. of contacts	dim. [mm]				art. no.	no. of contacts	dim. [mm]			
		A	B	C	D			A	B	C	D
DIL 6 P Z	6	7.62	10.10	4.10	7.60	DIL 22 P G	22	10.16	12.70	6.70	27.90
DIL 8 P ...	8	7.62	10.10	4.10	10.10	DIL 22 03 P ...	22	7.62	10.10	4.10	27.90
DIL 10 P ...	10	7.62	10.10	4.10	12.70	DIL 24 P G	24	15.24	17.70	11.70	30.60
DIL 14 P ...	14	7.62	10.10	4.10	17.70	DIL 24 03 P G	24	7.62	10.10	4.10	30.60
DIL 16 P ...	16	7.62	10.10	4.10	20.40	DIL 24 04 P ...	24	10.16	12.70	6.70	30.60
DIL 18 P ...	18	7.62	10.10	4.10	23.00	DIL 32 P Z	32	15.24	17.70	11.70	40.60
DIL 20 P ...	20	7.62	10.10	4.10	25.50	DIL 36 P ...	36	15.24	17.70	11.70	45.60

please indicate: ... surface
G=gold-plated
Z=tin-plated

High-precision sockets for DIL-IC, open frame

A

B

C

D

E

F

G

H

I

K

L

M

N

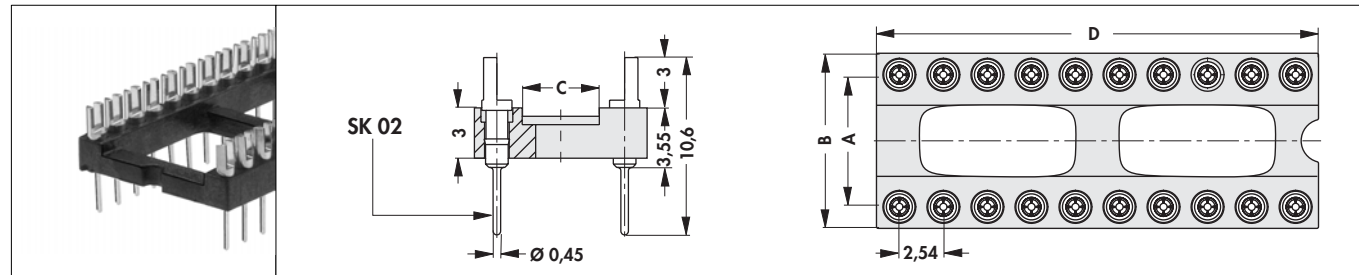

art. no.	no. of contacts	dim. [mm]				art. no.	no. of contacts	dim. [mm]			
		A	B	C	D			A	B	C	D
DIL 6 Q Z	6	7.62	10.10	4.10	7.60	DIL 20 Q Z	20	7.62	10.10	4.10	25.50
DIL 8 Q ...	8	7.62	10.10	4.10	10.10	DIL 24 03 Q G	24	7.62	10.10	4.10	30.60
DIL 10 Q Z	10	7.62	10.10	4.10	12.70	DIL 28 Q ...	28	15.24	17.70	11.70	35.70
DIL 14 Q Z	14	7.62	10.10	4.10	17.70	DIL 28 03 Q Z	28	7.62	10.10	4.10	35.70
DIL 16 Q ...	16	7.62	10.10	4.10	20.40	DIL 36 Q ...	36	15.24	17.70	11.70	45.60
DIL 18 Q ...	18	7.62	10.10	4.10	23.00						

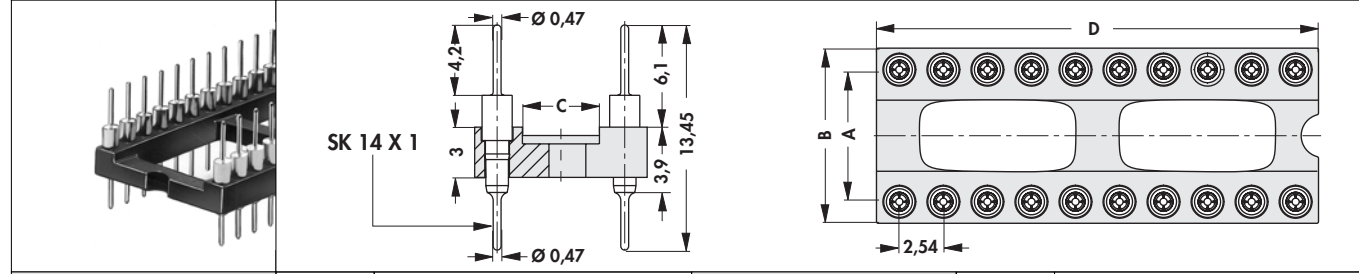

art. no.	no. of contacts	dim. [mm]				art. no.	no. of contacts	dim. [mm]			
		A	B	C	D			A	B	C	D
DIL 6 U ...	6	7.62	10.10	4.10	7.60	DIL 22 03 U Z	22	7.62	10.10	4.10	27.90
DIL 8 U ...	8	7.62	10.10	4.10	10.10	DIL 24 U ...	24	15.24	17.70	11.70	30.60
DIL 10 U Z	10	7.62	10.10	4.10	12.70	DIL 24 03 U ...	24	7.62	10.10	4.10	30.60
DIL 14 U ...	14	7.62	10.10	4.10	17.70	DIL 24 04 U Z	24	10.16	12.70	6.70	30.60
DIL 16 U ...	16	7.62	10.10	4.10	20.40	DIL 28 U ...	28	15.24	17.70	11.70	35.70
DIL 18 U Z	18	7.62	10.10	4.10	23.00	DIL 32 U G	32	15.24	17.70	11.70	40.60
DIL 20 U Z	20	7.62	10.10	4.10	25.50	DIL 36 U ...	36	15.24	17.70	11.70	45.60
DIL 22 U ...	22	10.16	12.70	6.70	27.90						

please indicate: ... surface
G=gold-plated
Z=tin-plated

High-precision sockets for DIL-IC, open frame

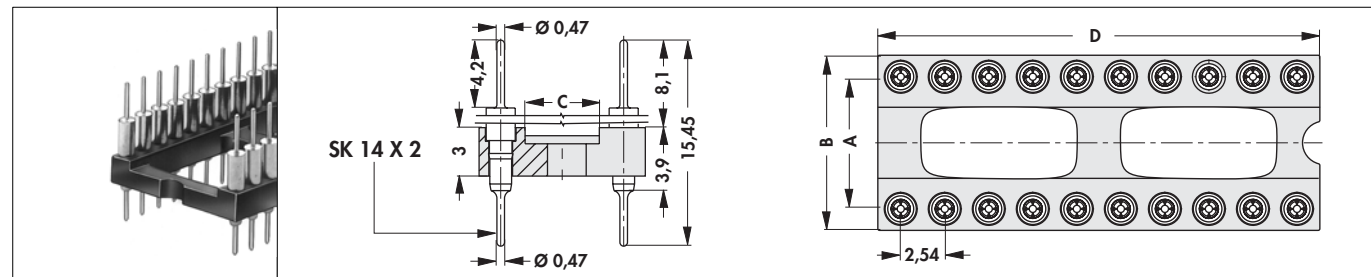

art. no.	no. of contacts	dim. [mm]				art. no.	no. of contacts	dim. [mm]			
		A	B	C	D			A	B	C	D
DIL 6 V ...	6	7.62	10.10	4.10	7.60	DIL 22 V G	22	10.16	12.70	6.70	27.90
DIL 8 V ...	8	7.62	10.10	4.10	10.10	DIL 22 03 V Z	22	7.62	10.10	4.10	27.90
DIL 10 V Z	10	7.62	10.10	4.10	12.70	DIL 24 03 V ...	24	7.62	10.10	4.10	30.60
DIL 14 V ...	14	7.62	10.10	4.10	17.70	DIL 24 04 V ...	24	10.16	12.70	6.70	30.60
DIL 16 V ...	16	7.62	10.10	4.10	20.40	DIL 28 V ...	28	15.24	17.70	11.70	35.70
DIL 18 V ...	18	7.62	10.10	4.10	23.00	DIL 28 03 V Z	28	7.62	10.10	4.10	35.70
DIL 20 V Z	20	7.62	10.10	4.10	25.50	DIL 36 V ...	36	15.24	17.70	11.70	45.60

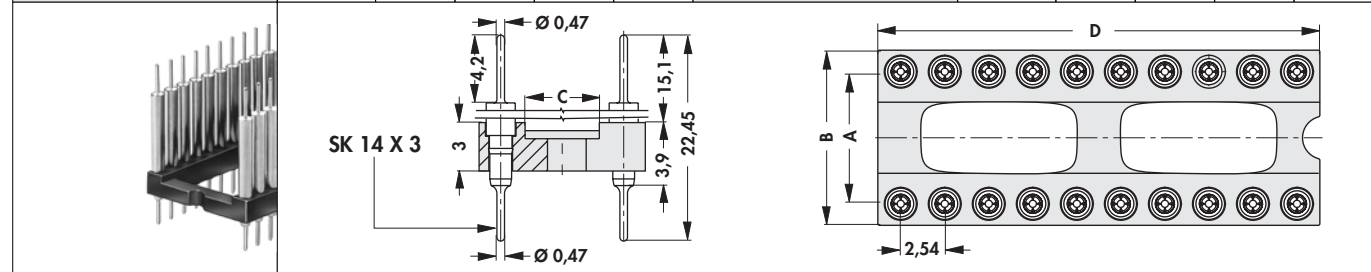

art. no.	no. of contacts	dim. [mm]				art. no.	no. of contacts	dim. [mm]			
		A	B	C	D			A	B	C	D
DIL 6 W Z	6	7.62	10.10	4.10	7.60	DIL 22 W Z	22	10.16	12.70	6.70	27.90
DIL 8 W ...	8	7.62	10.10	4.10	10.10	DIL 22 03 W ...	22	7.62	10.10	4.10	27.90
DIL 10 W ...	10	7.62	10.10	4.10	12.70	DIL 24 03 W Z	24	7.62	10.10	4.10	30.60
DIL 14 W ...	14	7.62	10.10	4.10	17.70	DIL 24 04 W ...	24	10.16	12.70	6.70	30.60
DIL 16 W G	16	7.62	10.10	4.10	20.40	DIL 32 W ...	32	15.24	17.70	11.70	40.60
DIL 18 W ...	18	7.62	10.10	4.10	23.00	DIL 36 W ...	36	15.24	17.70	11.70	45.60

please indicate: ... surface
G=gold-plated
Z=tin-plated

Socket layout of various numbers of contacts for DIL-IC, open frame

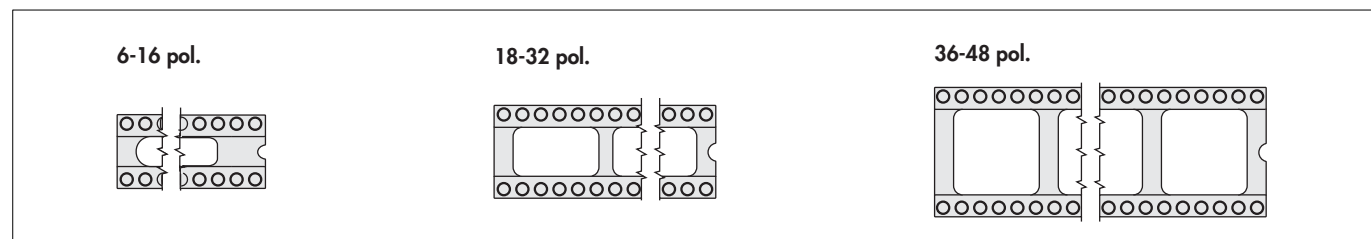

High-precision sockets for DIL-IC, closed frame

A

B

C

D

E

F

G

H

I

K

L

M

N

art. no.	no. of contacts	dim. [mm]	art. no.	no. of contacts	dim. [mm]
		A B D			A B D
DIL 6 E ...	6	7.62 10.30 7.60	DIL 20 E ...	20	7.62 10.30 25.50
DIL 8 E ...	8	7.62 10.30 10.10	DIL 28 E ...	28	15.24 17.70 35.50
DIL 14 E ...	14	7.62 10.30 17.70	DIL 32 E ...	32	15.24 17.70 40.60
DIL 16 E ...	16	7.62 10.30 20.40	DIL 40 E ...	40	15.24 17.70 50.80
DIL 18 E ...	18	7.62 10.30 23.00			
art. no.	no. of contacts	dim. [mm]	art. no.	no. of contacts	dim. [mm]
		A B D			A B D
DIL 6 H ...	6	7.62 10.30 7.60	DIL 22 H ...	22	10.16 12.70 27.90
DIL 8 H Z	8	7.62 10.30 10.10	DIL 28 H Z	28	15.24 17.70 35.50
DIL 14 H Z	14	7.62 10.30 17.70	DIL 32 H ...	32	15.24 17.70 40.60
DIL 16 H Z	16	7.62 10.30 20.40	DIL 36 H Z	36	15.24 17.70 45.60
DIL 18 H Z	18	7.62 10.30 23.00	DIL 40 H ...	40	15.24 17.70 50.80
DIL 20 H ...	20	7.62 10.30 25.50	DIL 48 H Z	48	15.24 17.70 61.30
art. no.	no. of contacts	dim. [mm]	art. no.	no. of contacts	dim. [mm]
		A B D			A B D
DIL 6 A G	6	7.62 10.30 7.60	DIL 18 A ...	18	7.62 10.30 23.00
DIL 8 A ...	8	7.62 10.30 10.10	DIL 36 A Z	36	15.24 17.70 45.60
DIL 14 A ...	14	7.62 10.30 17.70	DIL 40 A Z	40	15.24 17.70 50.80
DIL 16 A G	16	7.62 10.30 20.40	DIL 48 A Z	48	15.24 17.70 61.30
<p>please indicate: ... surface G=gold-plated Z=tin-plated</p>					

contact spring: gold-plated

SMD sockets for PLCC → F 18
 Programmable headers → F 23
 Technical data → F 31 - 34
 High-prec. male headers 2.54 solder → G 21 - 24

Single precision contacts → F 2 - 3
 Sockets for LED → F 11 - 12
 Fem. head. 2.54 solder, put through → G 29
 Peel-off terminal strips → G 25

F 8

High-precision sockets for DIL-IC, closed frame

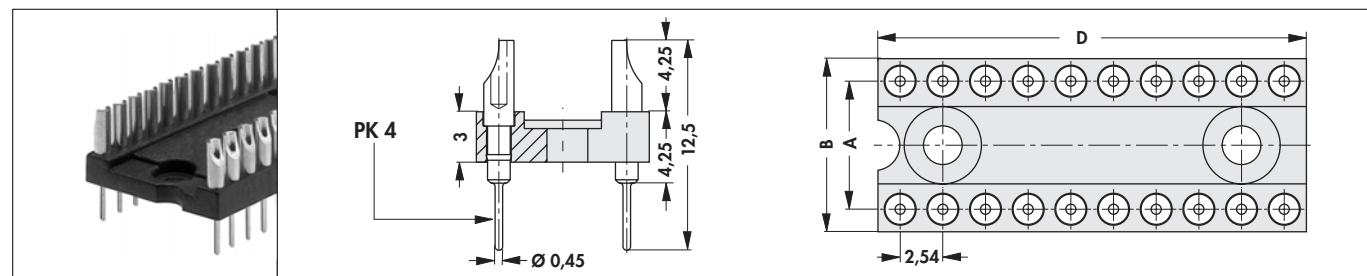

art. no.	no. of contacts	dim. [mm]			art. no.	no. of contacts	dim. [mm]		
		A	B	D			A	B	D
DIL 6 B ...	6	7.62	10.30	7.60	DIL 28 B Z	28	15.24	17.70	35.50
DIL 8 B G	8	7.62	10.30	10.10	DIL 32 B Z	32	15.24	17.70	40.60
DIL 14 B ...	14	7.62	10.30	17.70	DIL 36 B ...	36	15.24	17.70	45.60
DIL 16 B ...	16	7.62	10.30	20.40	DIL 40 B G	40	15.24	17.70	50.80
DIL 18 B ...	18	7.62	10.30	23.00	DIL 48 B ...	48	15.24	17.70	61.30
DIL 20 B ...	20	7.62	10.30	25.50					

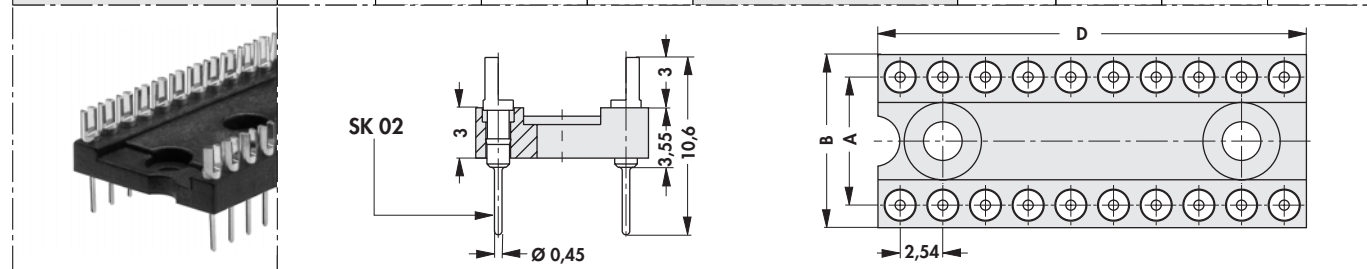

art. no.	no. of contacts	dim. [mm]			art. no.	no. of contacts	dim. [mm]		
		A	B	D			A	B	D
DIL 6 D ...	6	7.62	10.30	7.60	DIL 20 D ...	20	7.62	10.30	25.50
DIL 8 D ...	8	7.62	10.30	10.10	DIL 32 D G	32	15.24	17.70	40.60
DIL 14 D Z	14	7.62	10.30	17.70	DIL 36 D ...	36	15.24	17.70	45.60
DIL 16 D ...	16	7.62	10.30	20.40	DIL 48 D ...	48	15.24	17.70	61.30
DIL 18 D ...	18	7.62	10.30	23.00					

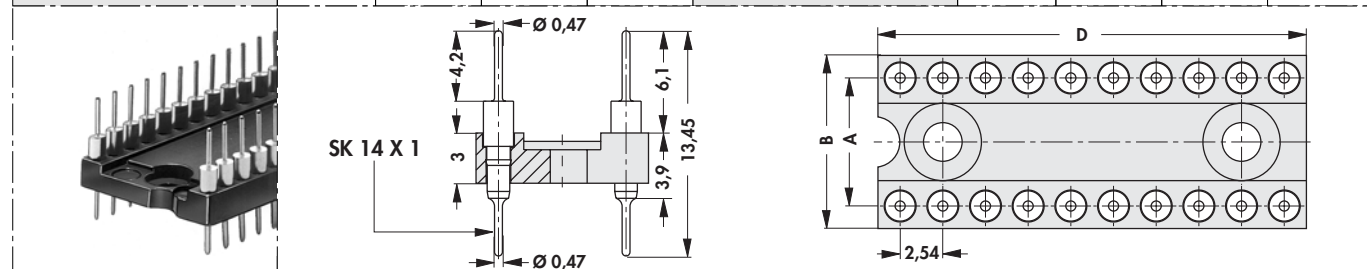

art. no.	no. of contacts	dim. [mm]			art. no.	no. of contacts	dim. [mm]		
		A	B	D			A	B	D
DIL 6 X ...	6	7.62	10.30	7.60	DIL 28 X Z	28	15.24	17.70	35.50
DIL 8 X G	8	7.62	10.30	10.10	DIL 32 X ...	32	15.24	17.70	40.60
DIL 14 X G	14	7.62	10.30	17.70	DIL 36 X ...	36	15.24	17.70	45.60
DIL 16 X ...	16	7.62	10.30	20.40	DIL 40 X ...	40	15.24	17.70	50.80
DIL 18 X ...	18	7.62	10.30	23.00	DIL 48 X ...	48	15.24	17.70	61.30
DIL 22 X ...	22	10.16	12.70	27.90					

please indicate: ... surface
G=gold-plated
Z=tin-plated

High-precision sockets for DIL-IC, closed frame

art. no.	no. of contacts	dim. [mm]			art. no.	no. of contacts	dim. [mm]		
		A	B	D			A	B	D
DIL 6 Y ...	6	7.62	10.30	7.60	DIL 22 Y G	22	10.16	12.70	27.90
DIL 8 Y ...	8	7.62	10.30	10.10	DIL 28 Y ...	28	15.24	17.70	35.50
DIL 14 Y Z	14	7.62	10.30	17.70	DIL 36 Y ...	36	15.24	17.70	45.60
DIL 16 Y ...	16	7.62	10.30	20.40	DIL 40 Y ...	40	15.24	17.70	50.80
DIL 18 Y ...	18	7.62	10.30	23.00	DIL 48 Y ...	48	15.24	17.70	61.30

please indicate: ... surface
G = gold-plated
Z = tin-plated

Socket layout of various numbers of contacts for DIL-IC, closed frame

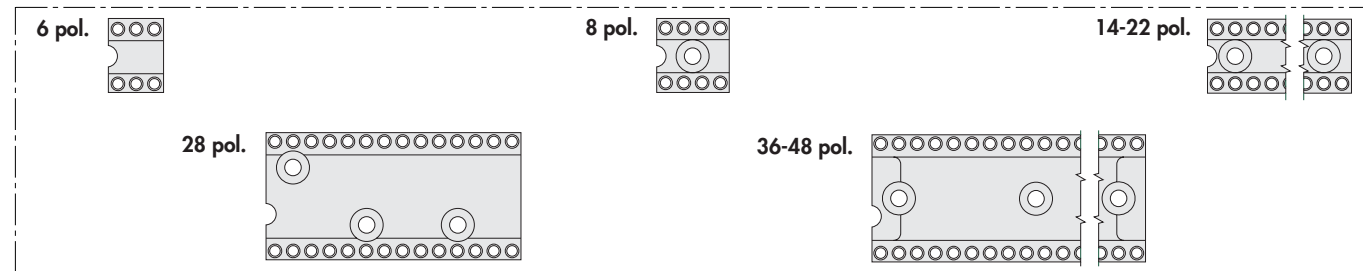

DIL-IC-sockets with extractor

art. no.	no. of contacts	dim. [mm]			
		A	B	C	D
DIL 14 PEK	14	7.62	10.10	12.00	17.00
DIL 16 PEK	16	7.62	10.10	12.00	20.30

contact shell surface: gold-plated

contact spring: gold-plated

High-precision sockets for DIL-IC

LED display sockets of 0.6" pitch

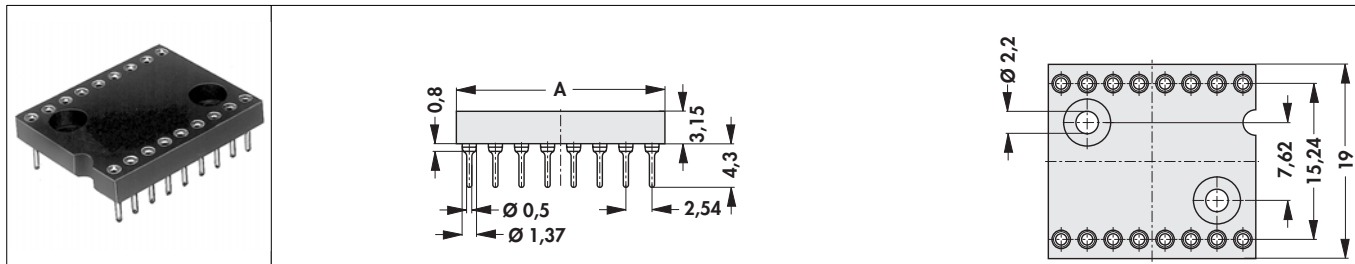

art. no.	no. of contacts	dim. [mm] A	art. no.	no. of contacts	dim. [mm] A
DIL 16 06 E Z	16	20.30	DIL 18 06 E ...	18	22.80

please indicate: ... surface
G = gold-plated
Z = tin-plated

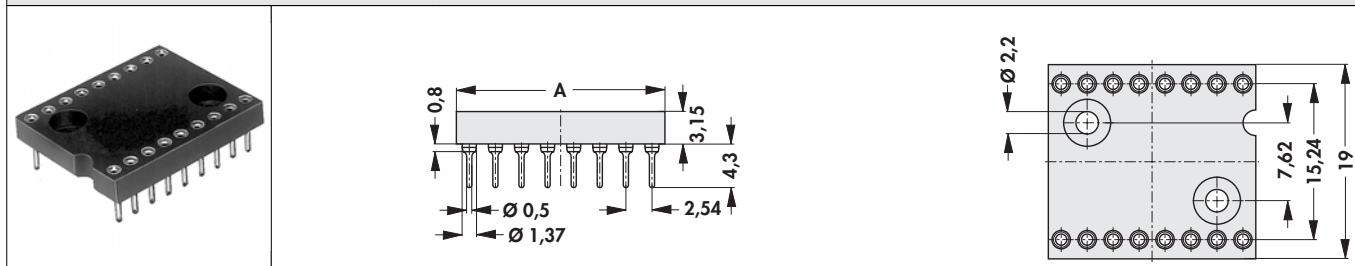

art. no.	no. of contacts	dim. [mm] A	art. no.	no. of contacts	dim. [mm] A
DIL 16 06 H Z	16	20.30	DIL 18 06 H Z	18	22.80

contact spring: gold-plated

High-precision sockets for DIL-IC

IC-sockets partially equipped, e.g. for oscillators and relays

	DIL 4 OR ...	DIL 8 1 OR ...	DIL 8 2 OR ...	
art. no.	no. of contacts	art. no.	no. of contacts	
DIL 4 OR ...	4	DIL 8 2 OR ...	8	
DIL 8 1 OR Z	8			
<p>please indicate: ... surface G = gold-plated Z = tin-plated</p>				

contact spring: gold-plated

LED display sockets in vertical construction

art. no.	no. of contacts	dim. [mm]	art. no.	no. of contacts	dim. [mm]
		A B			A B
DIL 14 W 90	14	27.70 22.70	DIL 16 W 90	16	30.30 25.30

contact shell surface: tin-plated; contact spring: gold-plated

art. no.	no. of contacts	dim. [mm]	art. no.	no. of contacts	dim. [mm]
		A			A
DIL 8 G ...	8	10.10	DIL 16 G ...	16	20.30
DIL 10 G ...	10	12.70	DIL 20 G ...	20	25.40
DIL 14 G ...	14	17.70			
<p>please indicate: ... surface G = gold-plated Z = tin-plated</p>					

contact spring: gold-plated

Mounting tool for DIL/PLCC

→ F 14

Single contacts metal strip Jumpers

→ G 26
 → G 77 - 78
 → G 2

Jump. links 2.00 & 2.54 solder Sockets for DIL-IC

→ G 20
 → F 4 - 10

Male con./fem. con. 6.00 solder

F 12

A

B

C

D

E

F

G

H

I

K

L

M

N

High-precision sockets for DIL-IC

DIL adaptor plugs

	PK 3	SK 02 (≅ PK 5)	PK 3	SK 02 (≅ PK 5)			
art. no.	no. of contacts	dim. [mm]		art. no.	no. of contacts	dim. [mm]	
		A	B			A	B
DILS 04 PK 5	4	5.00	2.54	DILS 16 PK 3	16	20.30	17.78
DILS 06 PK 3	6	7.60	5.08	DILS 16 PK 5	16	20.30	17.78
DILS 08 PK 3	8	10.10	7.62	DILS 18 PK 5	18	23.00	20.32
DILS 14 PK 3	14	17.70	15.24				
				PK 3	SK 02 (≅ PK 5)		
art. no.	no. of contacts	dim. [mm]		art. no.	no. of contacts	dim. [mm]	
		A	B			A	B
DILS 16 6 PK 3	16	20.30	17.78	DILS 28 6 PK 3	28	35.50	33.02
DILS 24 6 PK 5	24	30.50	27.94	DILS 40 6 PK 3	40	50.80	48.26

contact surface finish: gold-plated

DIL platforms

suitable for DIL-cases DILS ... GA LO

art. no.	no. of contacts	dim. [mm]			art. no.	no. of contacts	dim. [mm]		
		A	B	C			A	B	C
DILS 08 GO	8	12.40	12.50	7.62	DILS 24 GO	24	32.80	20.10	15.24
DILS 14 GO	14	20.00	12.50	7.62	DILS 28 GO	28	37.80	20.10	15.24
DILS 16 GO	16	22.60	12.50	7.62	DILS 40 GO	40	53.10	20.10	15.24
DILS 18 GO	18	25.20	12.50	7.62					

contact surface finish: gold-plated



DIL cases - grid spacing 2.54 mm

suitable for platforms DIL DILS ... GO

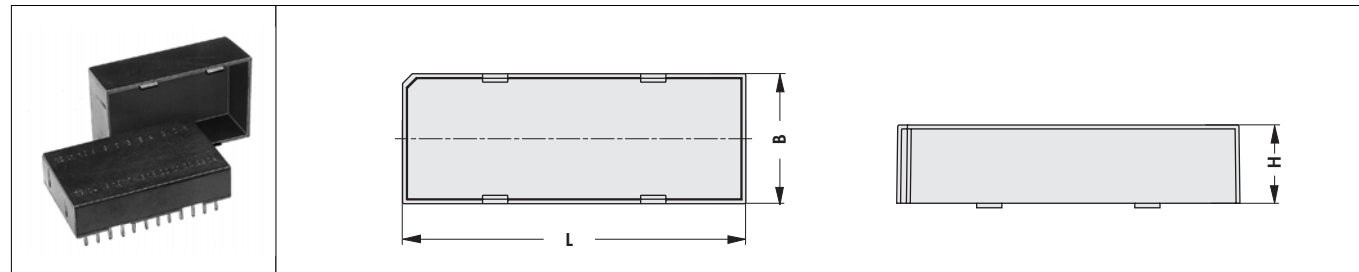

art. no.	dim. [mm]			art. no.	dim. [mm]		
	B	H	L		B	H	L
DILS 08 GA LO	12.50	6.70	12.40	DILS 14 GB LO	12.50	11.70	20.00
DILS 14 GA LO	12.50	6.70	20.00	DILS 16 GB LO	12.50	11.70	22.60
DILS 16 GA LO	12.50	6.70	22.60	DILS 18 GB LO	12.50	11.70	25.20
DILS 18 GA LO	12.50	6.70	25.20	DILS 24 GB LO	20.10	11.70	32.80
DILS 24 GA LO	20.10	6.70	32.80	DILS 28 GB LO	20.10	11.70	37.80
DILS 40 GA LO	20.10	6.70	53.10	DILS 40 GB LO	20.10	11.70	53.10
DILS 08 GB LO	12.50	11.70	12.40				

contact spring: gold-plated

IC-mounting tools - Design DIL



art. no.	spacing of contact rows
MIC 03	7.62
MIC 06	15.24

material: polyacetal, non-conductive; flammability: UL 94:HB

A

B

C

D

E

F

G

H

I

K

L

M

N

High-prec. male headers 2.54 solder → G 21 - 24
 Peel-off terminal strips → G 25
 High-prec. male head.in SMD mount. → G 35
 Technical data → F 31 - 34

DIL platform adapters & cases → F 13 - 14
 Teflon sockets/TO 5 & TO 18 → F 21 - 22
 Fem. head. 2.54 solder, put through → G 29
 Screw fastening → I 28

F 14

High-precision sockets for DIL-IC

SMD-plug for DIL

with PK 3-contacts

	art. no.	no. of contacts	dim. [mm]			
			A	B	C	D
DIL 08 SMD PK3 Z	8	7.62	10.10	3.50	10.00	
DIL 16 SMD PK3 ...	16	7.62	10.10	3.50	20.10	
DIL 20 SMD PK3 ...	20	7.62	10.10	3.50	25.20	
DIL 24 SMD PK3 ...	24	15.24	17.60	11.70	30.30	
<p>please indicate: ... surface G = gold-plated Z = tin-plated</p>						

with SK5-contacts

	art. no.	no. of contacts	dim. [mm]			
			A	B	C	D
DIL 08 SMD SK5 ...	8	7.62	10.10	3.50	10.00	
DIL 16 SMD SK5 ...	16	7.62	10.10	3.50	20.10	
DIL 20 SMD SK5 ...	20	7.62	10.10	3.50	25.20	
DIL 24 SMD SK5 ...	24	15.24	17.60	11.70	30.30	
<p>please indicate: ... surface G = gold-plated Z = tin-plated</p>						

SMD-socket for DIL IC

Contacts, especially integrated into the insulating part, will adjust to the solder paste which possibly is not equally distributed.

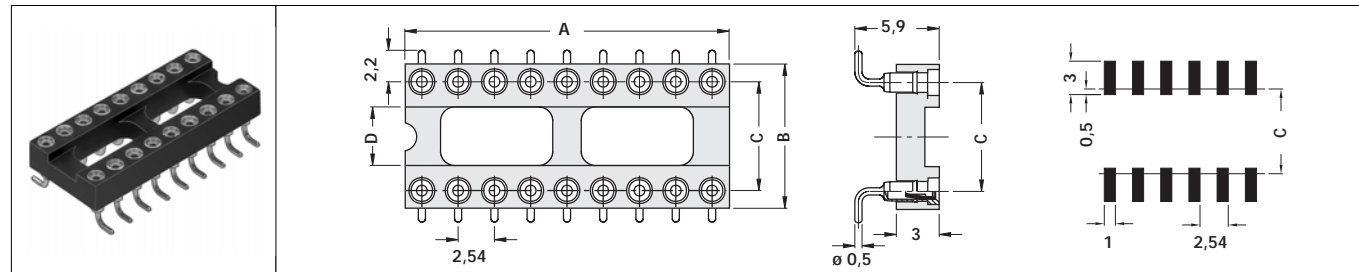

art. no.	no. of contacts	dim. [mm]			
		A	B	C	D
DIL 16 SMD M	16	20.10	10.10	7.62	3.50
DIL 20 SMD M	20	25.20	10.10	7.62	3.50
DIL 24 03 SMD M	24	30.30	10.10	7.62	3.50
DIL 28 SMD M	28	35.40	17.60	15.24	11.20

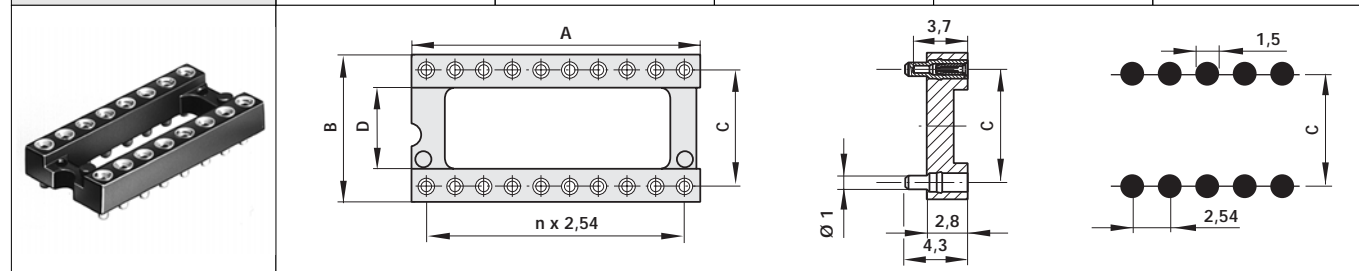

art. no.	no. of contacts	dim. [mm]			
		A	B	C	D
DIL SMD 08 Z	8	10.08	10.08	7.62	4.80
DIL SMD 10 Z	10	12.62	10.08	7.62	4.80
DIL SMD 16 Z	16	20.24	10.08	7.62	4.80
DIL SMD 22 03 Z	22	27.86	10.08	7.62	4.80
DIL SMD 22 04 Z	22	27.86	12.62	10.16	6.50
DIL SMD 28 06 Z	28	35.48	17.70	15.24	10.60
DIL SMD 32 Z	32	40.56	17.70	15.24	10.60
DIL SMD 40 Z	40	50.72	17.70	15.24	10.60

with centre bar for vacuum-mounting

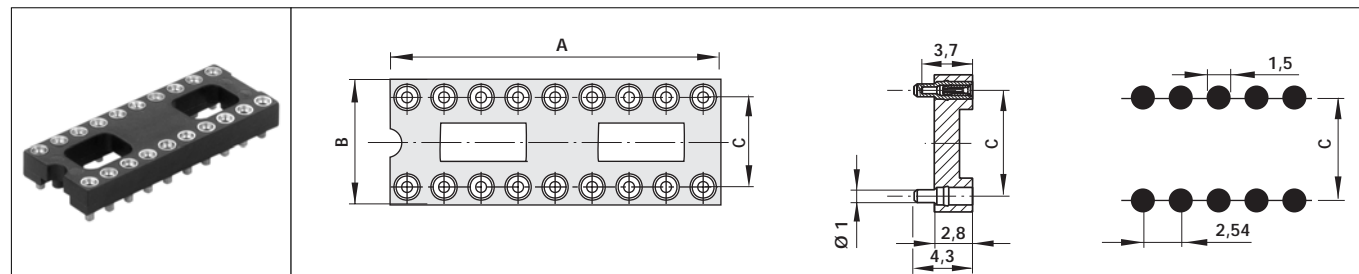

art. no.	no. of contacts	dim. [mm]		
		A	B	C
DIL SMD M 14 Z	14	17.70	10.08	7.62
DIL SMD M 28 06 Z	28	35.48	17.70	15.24
DIL SMD M 32 Z	32	40.56	17.70	15.24

contact shell surface: tin-plated; contact spring: gold-plated (DIL ... SMD M; DIL SMD ...; DIL SMD M ...)

Sockets for IC-PLCC

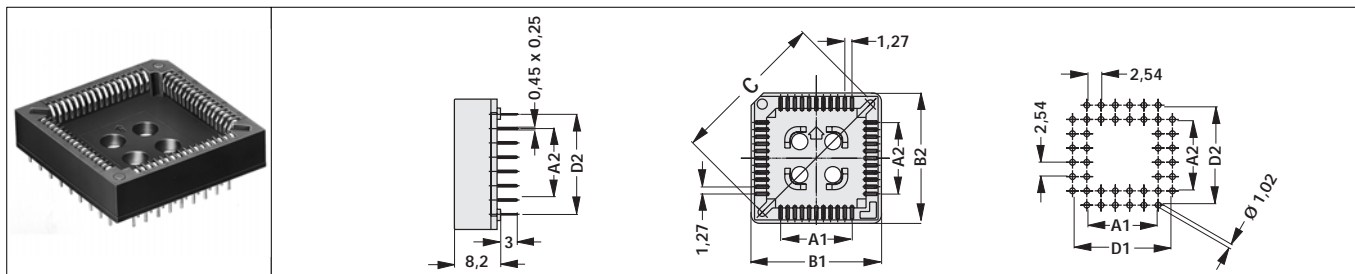

art. no.	no. of contacts	VPE	dim. [mm]						
			A1	A2	B1	B2	C	D1	D2
PLCC 20	20	39	5.08	5.08	15.55	15.55	16.70	10.16	10.16
PLCC 28	28	33	7.62	7.62	18.10	18.10	20.30	12.70	12.70
PLCC 32	32	29	7.62	10.16	18.10	20.70	22.20	12.70	15.24
PLCC 44	44	25	12.70	12.70	23.20	23.20	27.50	17.78	17.78
PLCC 52	52	23	15.24	15.24	25.70	25.70	31.00	20.32	20.32
PLCC 68	68	19	20.32	20.32	30.80	30.80	37.30	25.40	25.40
PLCC 84	84	16	25.40	25.40	36.00	36.00	44.50	30.48	30.48

contact surface finish: tin-plated; VPE = packing unit (pieces/tube)

Data sheet for pin configuration of PLCC sockets available on request.

These sockets conform to EIA/JEDEC "A" package requirements for leaded plastic chip carriers.

Drain holes for easier inside cleaning.

Test probe holes are moulded next to each contact, providing easy access.

Insulating material as per UL 94 V-0.

colour: black



Sockets for IC-PLCC

SMD sockets for PLCC - low profile housing

These sockets conform to EIA/JEDEC "A" package requirements for leaded plastic chip carriers.

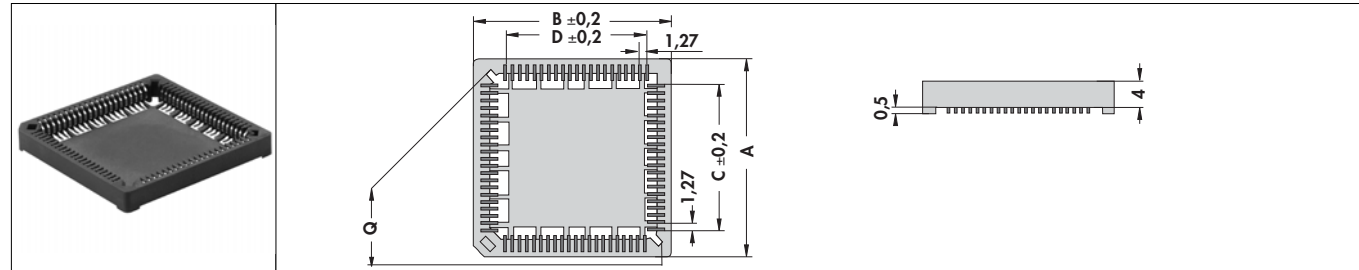

art. no.	no. of contacts	VPE	dim. [mm]				
			A	B	C	D	Q
PLCC 20 SMD	20	39	15.58	15.58	5.08	5.08	16.00
PLCC 28 SMD	28	32	18.12	18.12	7.62	7.62	20.60
PLCC 32 SMD	32	29	18.12	20.66	7.62	10.16	22.50
PLCC 44 SMD	44	26	23.40	23.40	12.70	12.70	27.50
PLCC 52 SMD	52	23	25.74	25.74	15.24	15.24	31.10
PLCC 68 SMD	68	19	30.82	30.82	20.32	20.32	38.80
PLCC 84 SMD	84	15	35.90	35.90	25.40	25.40	44.80

VPE = packing unit (pieces/tube)*dimensions ± 0.2 mm

Tin-plated phosphorbronze socket contacts.

colour: black

packing: bar magazine

- Dual polarisation indicators guarantee the correct alignment of the device.
- Drain holes for easier inside cleaning.
- Test probe holes are moulded next to each contact, providing easy access.
- Efficient heat dissipation.

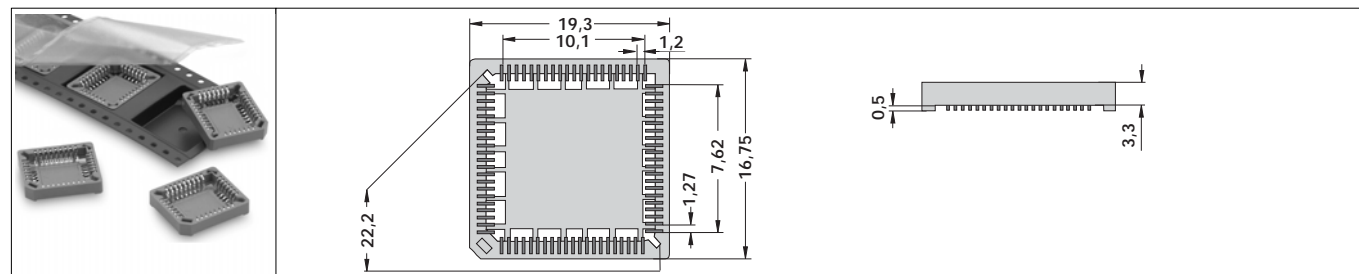

Insulating material (PBT) UL 94 V-0 rated.

SMD-sockets for PLCC - low profile housing

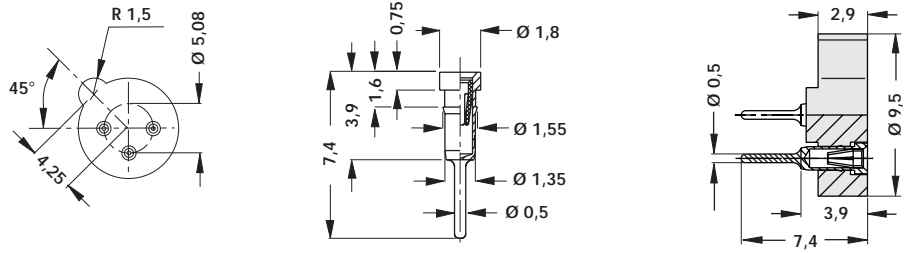

art. no.	no. of contacts
PLCC 32 LP SMD ...	32
please indicate:	... packing (option) SM = tube magazine TR = tape and reel (500 pcs/reel)

Sockets for TO 5

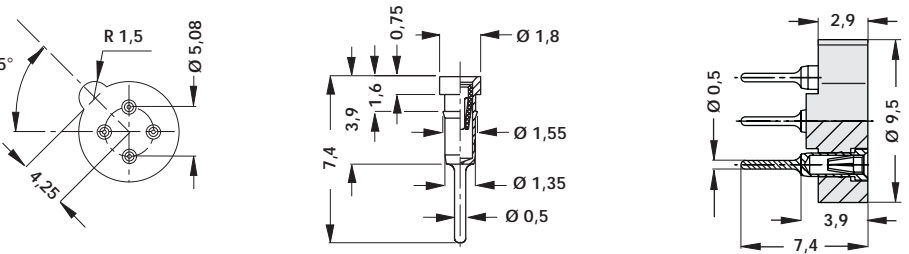
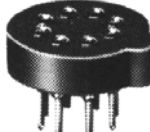
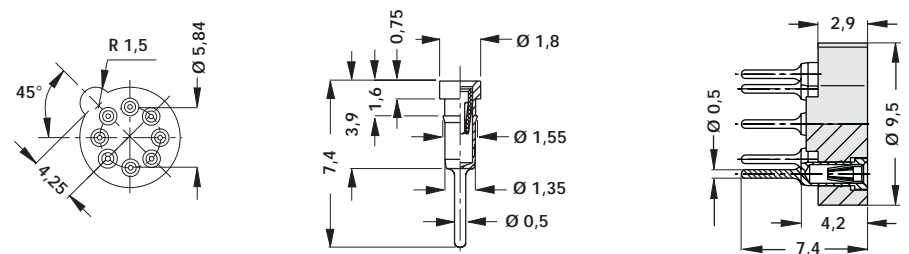
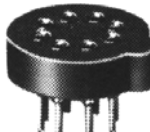
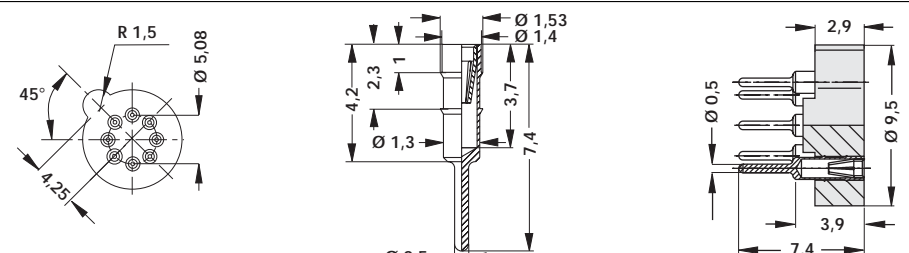
	
art. no. PF 53 ...	no. of contacts 3
	
art. no. PF 54 ...	no. of contacts 4
	
art. no. PF 58 23 ...	no. of contacts 8
	
art. no. PF 58 2 ...	no. of contacts 8
please indicate:	... surface G = gold-plated Z = tin-plated

contact spring: gold-plated

Sockets for TO 5

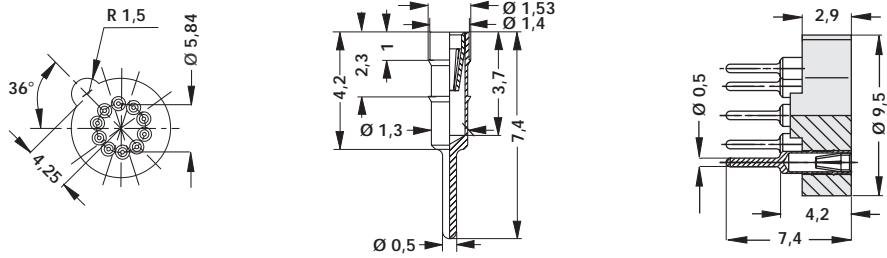
	
art. no.	no. of contacts
PF 510 ...	10
please indicate:	... surface G =gold-plated Z =tin-plated

contact spring: gold-plated

Sockets for power transistors TO 3

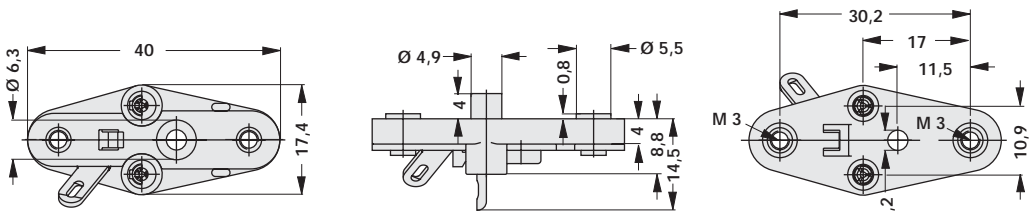
	
art. no.	no. of contacts
TF 3 2	3

insulator: PCT, glassfibre filled

contact: beryllium copper; 4 ... 6 µm Sn

Technical data:

current rating: 15 A max.

capacitance: 1 pF

contact resistance: <10 mΩ

insulation resistance: >10¹⁰ Ω/cm

temperature range: -65 °C ... +290 °C

test voltage: 1650 V

A

B

C

D

E

F

G

H

I

K

L

M

N

Single contacts metal strip
Jumper links
Female headers 2.54 press-fit
Teflon sockets/TO 5 & TO 18







→ G 26
→ F 24
→ G 53
→ F 21 - 22

Peel-off terminal strips
DIL platform adapters & cases
Connector-sleeves

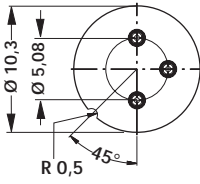
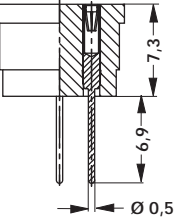
→ G 25
→ F 13 - 14
→ F 25 - 27

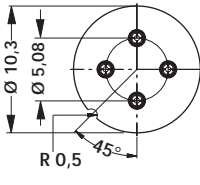
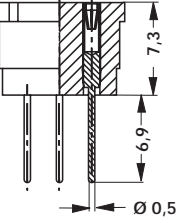

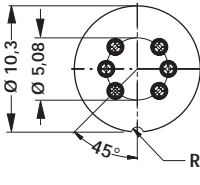
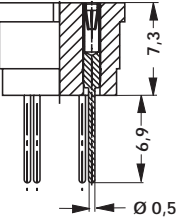

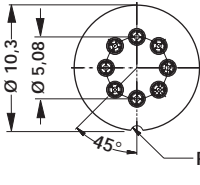
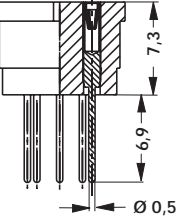
F 20

Transistor sockets - teflon sockets for TO 5





		
art. no. TF 53	no. of contacts 3	
		
art. no. TF 54	no. of contacts 4	
		
art. no. TF 56	no. of contacts 6	
		
art. no. TF 58	no. of contacts 8	

contact shell and contact spring: gold-plated

Transistor sockets - teflon sockets for TO 5

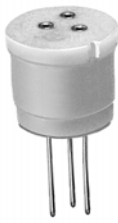
	
art. no.	no. of contacts
TF 510	10
	
art. no.	no. of contacts
TF 512	12

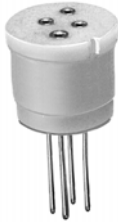
Transistor sockets - teflon sockets for TO 18

	
art. no.	no. of contacts
TF 183	3
	
art. no.	no. of contacts
TF 184	4

contact shell and contact spring: gold-plated

Programmable headers

Version for soldering technique

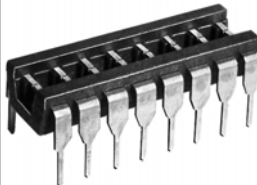
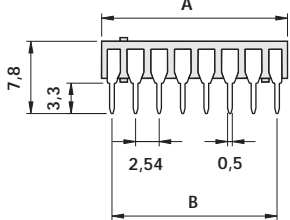
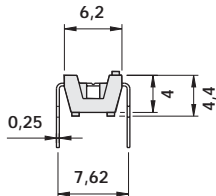
			
art. no.	no. of contacts	dim. [mm]	
		A	B
CAB 3 02 03 Z	2	2.22	-
CAB 3 04 03 Z	4	4.76	2.54
CAB 3 06 03 Z	6	7.30	5.08
CAB 3 08 03 Z	8	9.84	7.62
CAB 3 10 03 Z	10	12.38	10.16
CAB 3 12 03 Z	12	14.92	12.70
CAB 3 14 03 Z	14	17.46	15.24
CAB 3 16 03 Z	16	20.00	17.78

contacts: brass

The contacts have a preformed dividing groove and can easily be separated with a screwdriver blade.

Version for SMD technology

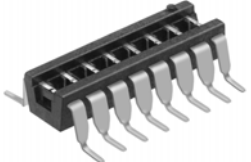
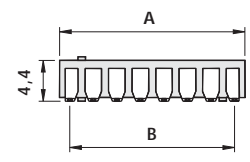
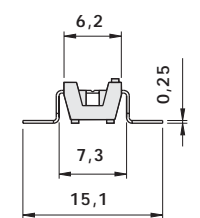
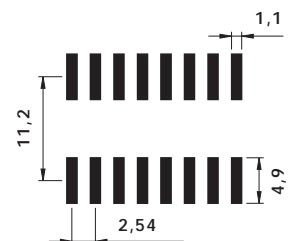
			
art. no.	no. of contacts	dim. [mm]	
		A	B
CAB 3 SMD 04 Z	4	4.76	2.54
CAB 3 SMD 08 Z	8	9.84	7.62
CAB 3 SMD 10 Z	10	12.38	10.16
CAB 3 SMD 12 Z	12	14.92	12.70
CAB 3 SMD 14 Z	14	17.46	15.24
CAB 3 SMD 16 Z	16	20.00	17.78

contacts: brass

The contacts have a preformed dividing groove and can easily be separated with a screwdriver blade.

A

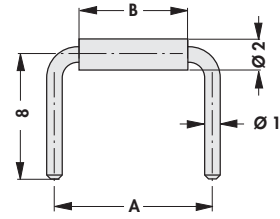
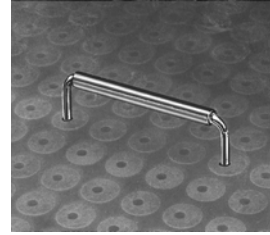

B

C

art. no.	dim. [mm]	
	A	B
LB 02 G	5.08	2.00
LB 03 G	7.62	4.50
LB 04 G	10.16	7.00
LB 06 G	15.24	12.00

D

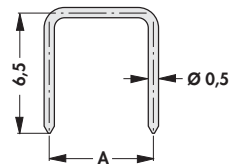
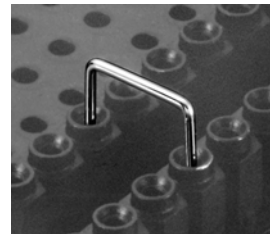

E

F

art. no.	dim. [mm]	
	A	
CB 1 ...	2.54	
CB 3 ...	5.08	
CB 6 ...	7.62	

please indicate: ... surface
G=gold-plated
Z=tin-plated

G

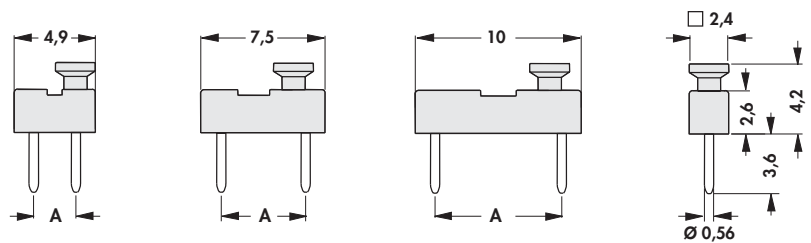
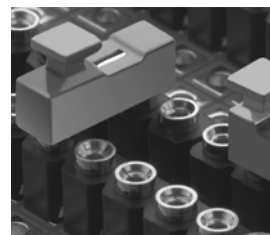

H

I

art. no.	dim. [mm]	
	A	
LEB 01 G	2.54	
LEB 02 G	5.08	
LEB 03 G	7.62	

K

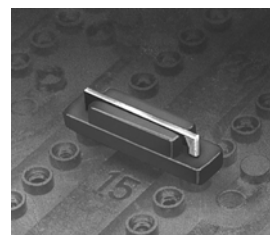

L

art. no.
PSB 03 G

M

Mounting tool for DIL/PLCC → F 14
 Single precision contacts F 2
 - 3
 High-prec. male headers 2.54 solder G 21
 - 24

N

for 0.4 mm with BeCu spring 3 μm Ni, 1 μm Au

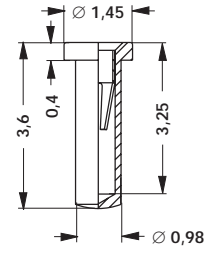
	
art. no.	
SB 1	

for 0.4 mm with bronze spring, teflon insulated

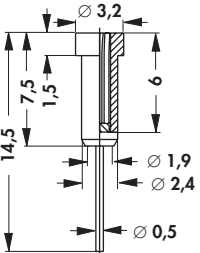
	
art. no.	
SB 2	

for 0.8 mm, slotted

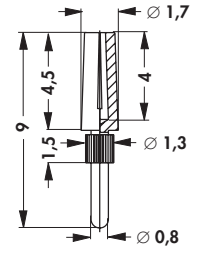
	
art. no.	
SB 3	

for 1 mm, slotted

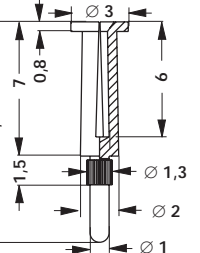
	
art. no.	
SB 4	

material: brass 2 μm Ni, 0.25 μm Au (unless otherwise stated)

for 1 mm, slotted

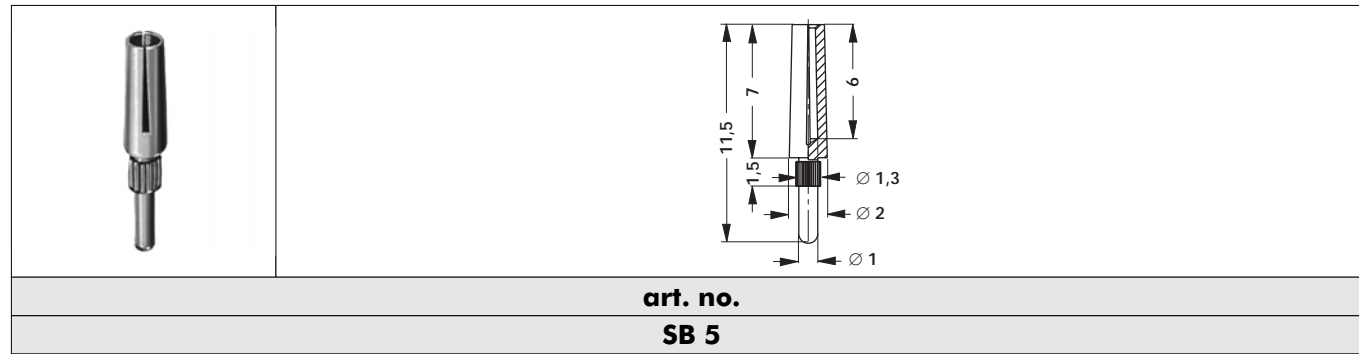

for 1 mm, slotted

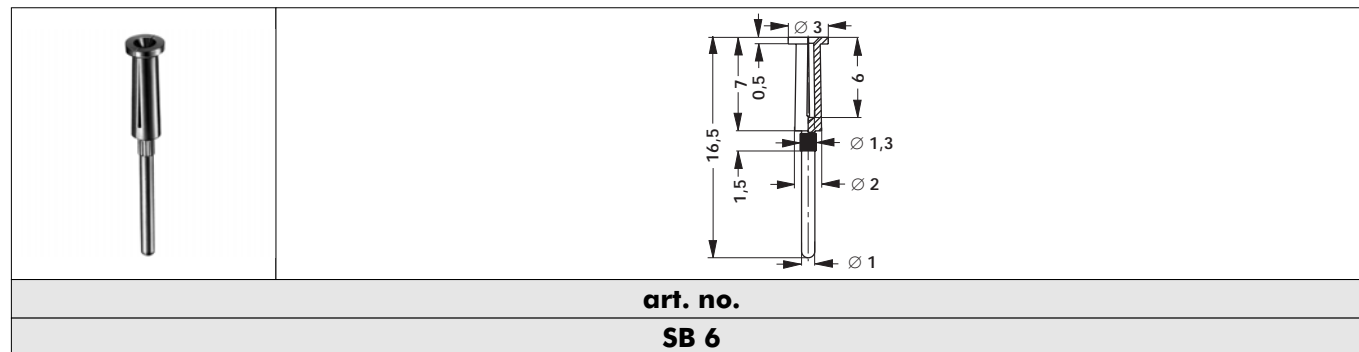

for 1 mm, slotted, plastic insulated

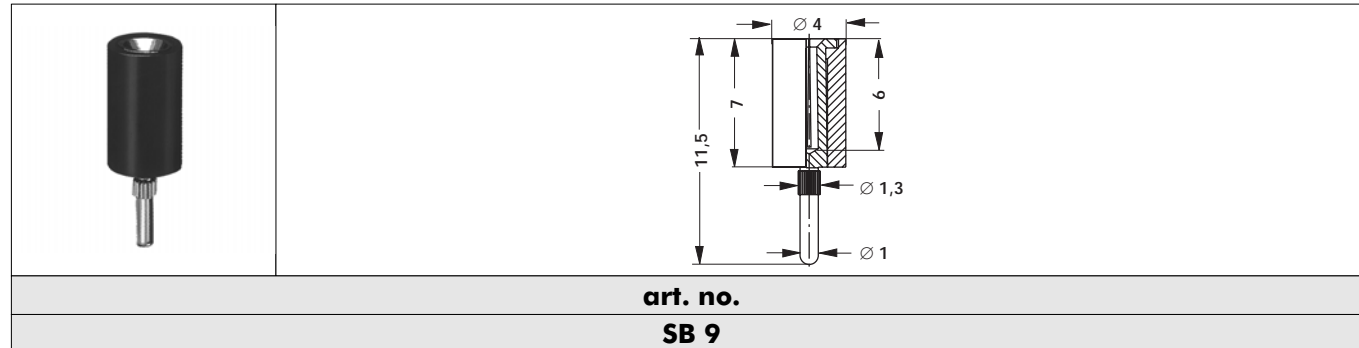

for 1 mm, with BeCu spring 3 μm Ni, 1 μm Au

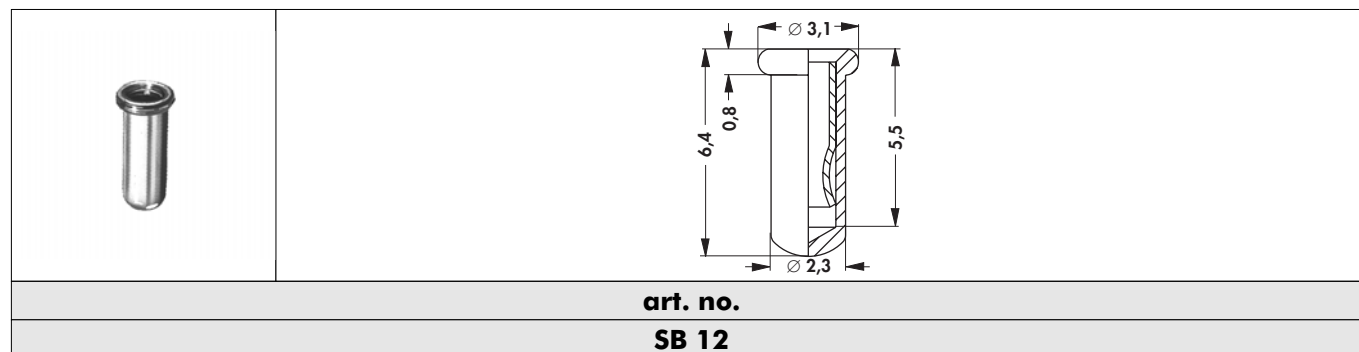

material: brass 2 μm Ni, 0.25 μm Au (unless otherwise stated)

A

B

C

D

E

F

G

H

I

K

L

M

N

for 1 mm, slotted, plastic insulated

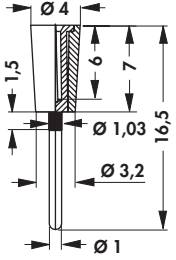
	
art. no.	
SB 16	

for 2 mm, slotted, plastic insulated

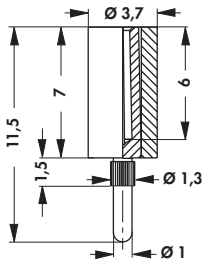
	
art. no.	
SB 13 ...	
please indicate:	... case colour B = blue R = red S = black

for 2 mm, slotted, plastic insulated, separable

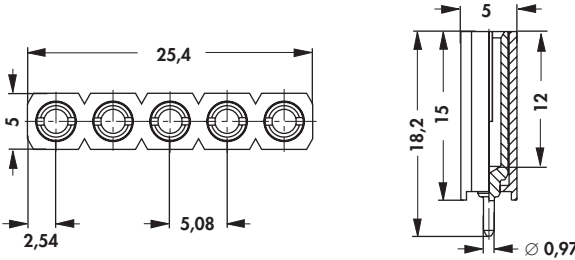
	
art. no.	
SB 15	

material: brass 2 μm Ni, 0.25 μm Au (unless otherwise stated)

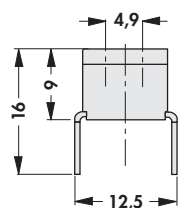
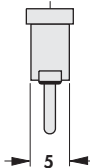
	 
art. no. QS 25 GS	

contact surface finish: silver-plated

Precision sockets for crystal oscillators in case HC 18

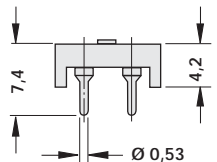
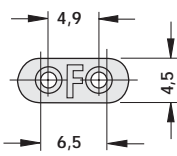
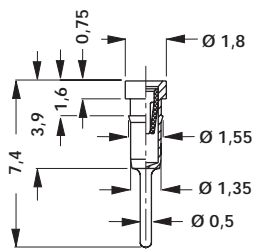
	  
art. no. PQ 18 ...	

please indicate: ... surface
G = gold-plated
Z = tin-plated

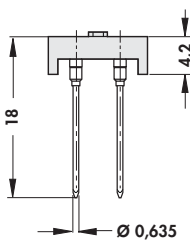
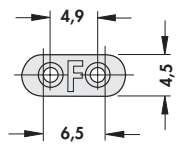
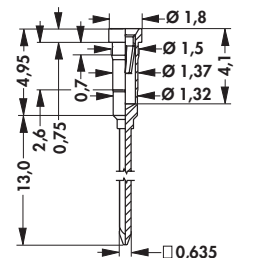
	  
art. no. PQ 18 W ...	

please indicate: ... surface
G = gold-plated
Z = tin-plated

contact spring: gold-plated

Insulators for crystal mounts

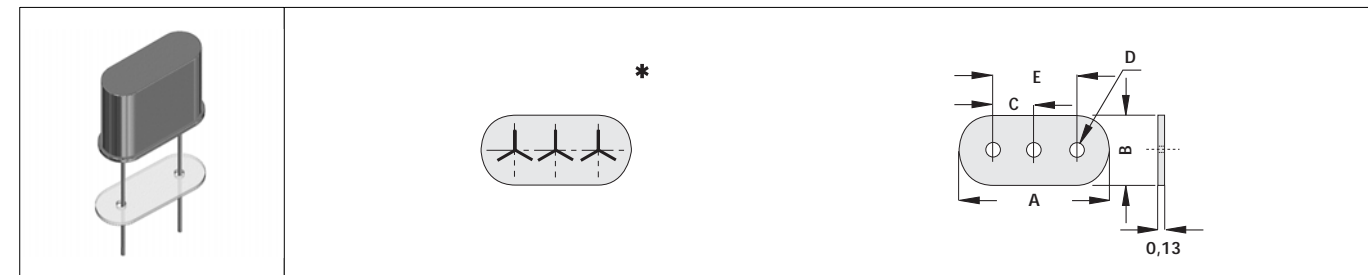

art. no.	case design	dim. [mm]				
		A	B	C	D	E (max.)
ISQ 01	HC-80/U	8.30	3.70	-	0.71	3.80
ISQ 02	HC-80/U	8.30	3.70	-	*	3.80
ISQ 03	HC-80/U	8.30	3.70	1.90	0.71	3.80
ISQ 04	HC-18/U, HC-43/U, HC-49/U	11.80	5.60	-	0.71	4.90
ISQ 05	HC-18/U, HC-43/U, HC-49/U	11.80	5.60	-	*	4.90
ISQ 06	HC-18/U, HC-43/U, HC-49/U	11.80	5.60	2.40	0.71	4.90
ISQ 07	HC-18/U, HC-43/U, HC-49/U	11.80	5.60	2.40	*	4.90
ISQ 08	HC-25/U, HC-42/U, HC-50/U	11.80	5.60	-	1.30	4.90

* = self retaining

Technical data:

foil: MYLAR
 thickness: 0.127 mm
 heat resistance: 250 °C
 dielectric strength: 9 KV

Male connector

one row, angled

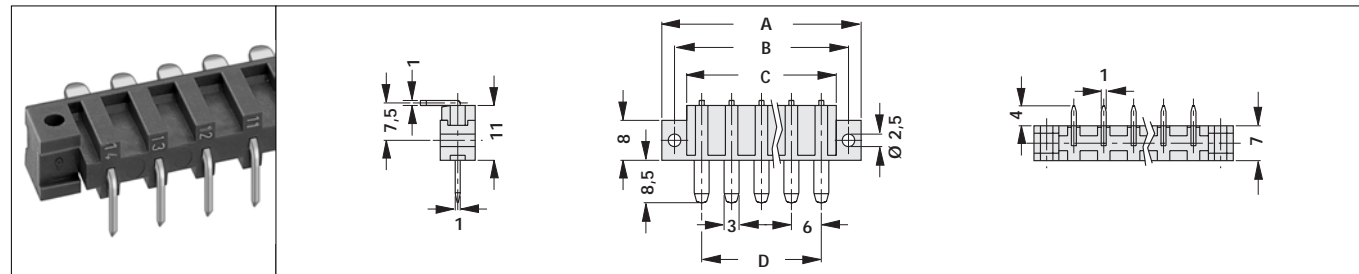

art. no.	no. of contacts	dim. [mm]			
		A	B	C	D
MELA 05	5	40.00	34.90	30.00	24.00
MELA 07	7	52.00	46.90	42.00	36.00

surface: silver-plated

As per DIN 41622.

PCB perforation

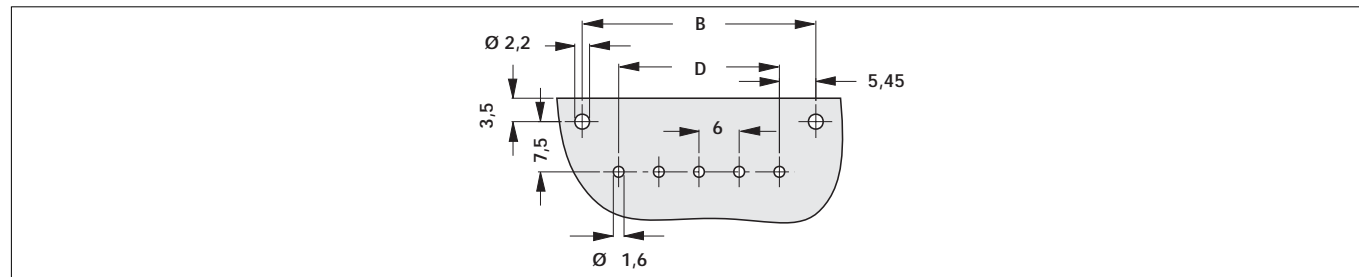

High-precision male headers soldering technique

Solder and plug pins, Ø 0.5 mm

art. no.			art. no.		
MK 05 ...			MK 205 ...		
art. no.			art. no.		
MK 03 ...			MK 203 ...		
art. no.			art. no.		
MK 04 ...			MK 204 ...		
art. no.			art. no.		
MK 02 ...			MK 202 ...		
please indicate:	... no. of contacts one row 1-50 two rows 2-100		... surface G=gold-plated Z=tin-plated		

Also available as single contact, SK ...

version:

MK 05 / MK 205: contact pin on both sides

MK 03 / MK 203: with solder button

MK 04 / MK 204: with diagonal solder bucket

MK 02 / MK 202: with solder fork

High-precision male headers soldering technique

Wire wrap pin, □ 0,635 mm

art. no.			art. no.		
MK 11 ...			MK 211 ...		
art. no.			art. no.		
MK 10 ...			MK 210 ...		
art. no.			art. no.		
MK 08 ...			MK 208 ...		
please indicate:	... no. of contacts one row 1-50 two rows 2-100		... surface G=gold-plated Z=tin-plated		

version:

MK 11 / MK 211: solder and plug pin, Ø 0.5 mm

MK 10 / MK 210: with diagonal solder bucket

MK 08 / MK 208: with solder fork

High-precision male headers soldering technique

Solder and plug pins, Ø 0,5 mm

art. no.			art. no.			
MK 51 ...			MK 251 ...			
art. no.						
MK 15 ...						
art. no.			art. no.			
	A	X		A	B	X
MK 14 X 1 ...	13.4	2.7	MK 214 X 1 ...	13.4	1.9	2.7
MK 14 X 2 ...	15.4	4.7	MK 214 X 2 ...	15.4	3.9	4.7
MK 14 X 3 ...	22.2	11.7	MK 214 X 3 ...	22.2	10.9	11.7
please indicate:	... no. of contacts one row 1-50 two rows 2-100		... surface G=gold-plated Z=tin-plated			

version:

MK 51 ... / MK 251 ... / MK 15 ...: 90° PCB connection
 MK 14 X ... / MK 214 X ...: parallel PCB connection

High-precision male headers soldering technique

Low profile

art. no.			art. no.		
art. no.			art. no.		
art. no.			art. no.		
art. no.					
please indicate:	... no. of contacts one row 1-50 two rows 4-100		... surface	G = gold-plated Z = tin-plated	

Also available as single contact, SK ...

B

C

D

E

F

G

H

I

K

L

M

N

Male headers soldering technique

0.635 mm, standard

art. no.	dim. [mm]			art. no.	dim. [mm]		
	A	B	C		A	B	C
SL 11 097...	9.70	3.00	3.90	SL 1 025 ...	11.20	2.60	5.80
SL 11 112 ...	11.20	3.00	5.40	SL 1 053 ...	13.90	5.80	5.30
SL 11 124 ...	12.40	3.00	6.60	SL 1 078 ...	16.40	5.80	7.80
SL 11 139 ...	13.90	3.00	8.10	SL 1 104 ...	19.00	5.80	10.40
SL 11 164 ...	16.40	3.00	10.60	SL 1 128 ...	21.40	5.80	12.80
SL 11 190 ...	19.00	3.00	13.20	SL 1 154 ...	24.00	5.80	15.40
SL 11 214 ...	21.40	3.00	15.60	SL 1 179 ...	26.50	5.80	17.90
SL 11 240 ...	24.00	3.00	18.20	SL 1 230 ...	31.60	5.80	23.00
SL 11 265 ...	26.50	3.00	20.70		-	-	-
SL 11 316 ...	31.60	3.00	25.80				
art. no.	dim. [mm]			art. no.	dim. [mm]		
	A	B	C		A	B	C
SL 22 097 ...	9.70	3.00	3.90	SL 2 025 ...	11.20	2.60	5.80
SL 22 112 ...	11.20	3.00	5.40	SL 2 053 ...	13.90	5.80	5.30
SL 22 124 ...	12.40	3.00	6.60	SL 2 078 ...	16.40	5.80	7.80
SL 22 139 ...	13.90	3.00	8.10	SL 2 104 ...	19.00	5.80	10.40
SL 22 164 ...	16.40	3.00	10.60	SL 2 128 ...	21.40	5.80	12.80
SL 22 190 ...	19.00	3.00	13.20	SL 2 154 ...	24.00	5.80	15.40
SL 22 214 ...	21.40	3.00	15.60	SL 2 179 ...	26.50	5.80	17.90
SL 22 240 ...	24.00	3.00	18.20	SL 2 230 ...	31.60	5.80	23.00
SL 22 265 ...	26.50	3.00	20.70		-	-	-
SL 22 316 ...	31.60	3.00	25.80				
please indicate:	... no. of contacts			... surface			
	one row 1-36			S = selective gold-plated			
	two rows 2-72			G = gold-plated			
				Z = tin-plated			

Every pin length is available on request.

Male header in through-hole-reflow-soldering technique

0.635 mm, THR soldering technique

art. no.	dim. [mm]		
	A	B	C
SL 20 THR 097 ...	9.70	2.00	4.90
SL 20 THR 112 ...	11.20	2.00	6.40
SL 20 THR 124 ...	12.40	2.00	7.60
SL 20 THR 139 ...	13.90	2.00	9.10
SL 20 THR 164 ...	16.40	2.00	11.60
please indicate:	... no. of contacts one row 1-36	... surface S = selective gold-plated G = gold-plated Z = tin-plated	
art. no.	dim. [mm]		
	A	B	C
SL 21 THR 097 ...	9.70	2.00	4.90
SL 21 THR 112 ...	11.20	2.00	6.40
SL 21 THR 124 ...	12.40	2.00	7.60
SL 21 THR 139 ...	13.90	2.00	9.10
SL 21 THR 164 ...	16.40	2.00	11.60
please indicate:	... no. of contacts two rows 2-72	... surface S = selective gold-plated G = gold-plated Z = tin-plated	

Every pin length is available on request.

"dimensions A + B" changeable

one row, □ 0.635 mm

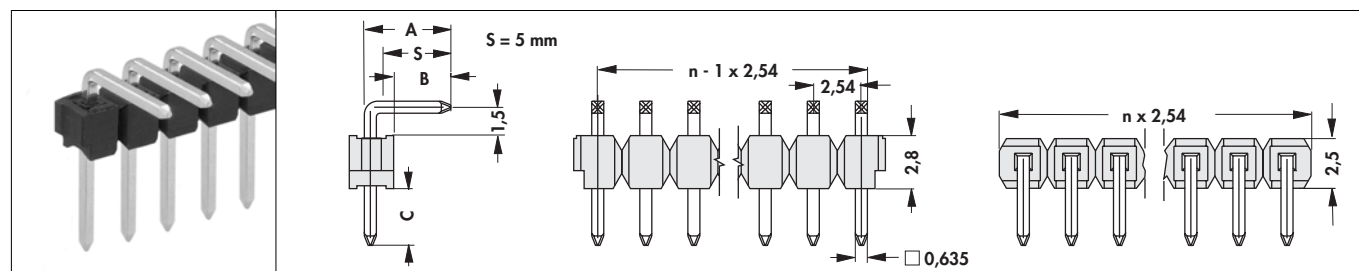

art. no.	dim. [mm]			art. no.	dim. [mm]		
	A	B	C		A	B	C
SLK 3 025 ...	4.50	3.00	3.00	SL 3 131 ...	14.60	13.10	5.80
SL 3 025 ...	4.50	3.00	5.80	SL 3 152 ...	16.70	15.20	5.80
SL 3 053 ...	6.90	5.40	5.80	SL 3 182 ...	19.70	18.20	5.80
SL 3 080 ...	9.50	8.00	5.80	SL 3 207 ...	22.20	20.70	5.80
SL 3 101 ...	11.60	10.10	5.80				

please indicate: ... no. of contacts one row 1-36 ... surface S = selective gold-plated G = gold-plated Z = tin-plated

The surface of dimension "C" of following articles is selective gold-plated: SLK 3 025 ... S, SL 3 025 ... S.

two rows, □ 0.635 mm

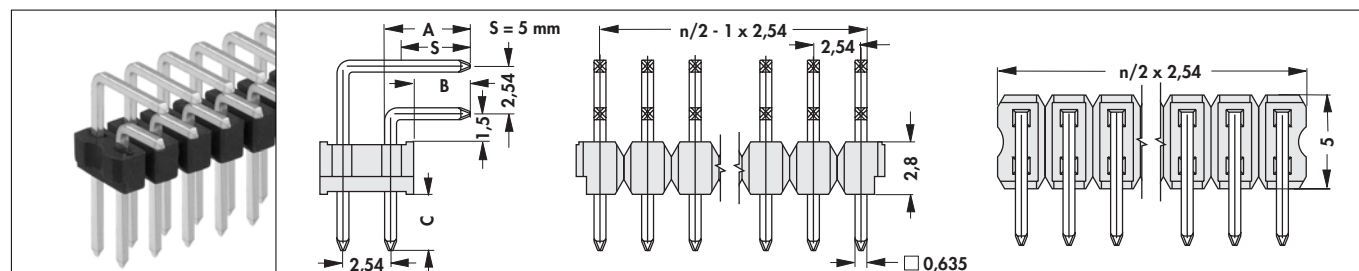

art. no.	dim. [mm]			art. no.	dim. [mm]		
	A	B	C		A	B	C
SLK 4 025 ...	4.50	3.00	3.00	SL 4 101 ...	11.60	10.10	5.80
SL 4 025 ...	4.50	3.00	5.80	SL 4 152 ...	16.70	15.20	5.80

please indicate: ... no. of contacts two rows 2-72 ... surface S = selective gold-plated G = gold-plated Z = tin-plated

The surface of dimension "C" of following articles is selective gold-plated: SLK 4 025 ... S, SL 4 025 ... S.

V-notches permit breaking! Therefore any required number of contacts is available. Every pin length is available on request.

- IDC-connectors → H 1 - 14
- Female headers 2.54 solder → G 27
- Female headers 2.54 SMD → G 46 - 49
- Fem. head. 2.54 solder, put through → G 29

- Special male & female headers → G 19
- High-prec. fem. headers 2.54 sold. → G 31 - 34
- High-prec. male head.in SMD mount. → G 35
- Technical data → G 75 - 80

G 10

Male headers soldering technique

Insertion side "dimension C" changeable

one row, □ 0.635 mm

art. no.	dim. [mm]		
	C		
SL 18 042 ...	4.20		
SL 18 082 ...	8.20		
SL 18 108 ...	10.80		
SL 18 132 ...	13.20		
SL 18 159 ... S	15.90		
please indicate:	... no. of contacts one row 1-36	... surface S = selective gold-plated G = gold-plated Z = tin-plated	

two rows, □ 0.635 mm

art. no.	dim. [mm]		
	C		
SL 19 082 ...	8.20		
SL 19 108 ...	10.80		
SL 19 132 ...	13.20		
SL 19 159 ... S	15.90		
please indicate:	... no. of contacts two rows 2-72	... surface S = selective gold-plated G = gold-plated Z = tin-plated	

V-notches permit breaking! Therefore any required number of contacts is available.
Every pin length is available on request.

Low profile, straight

one row, □ 0.635 mm

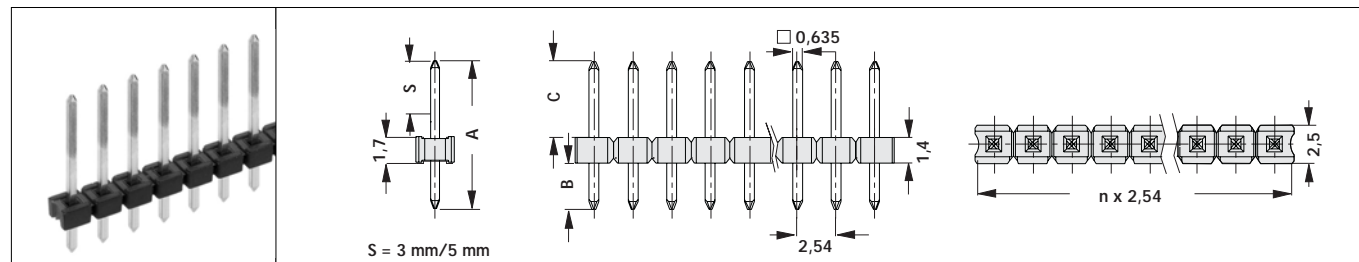

art. no.	dim. [mm]			art. no.	dim. [mm]		
	A	B	C		A	B	C
SL LP 1 082 ...	8.20	3.00	3.50	SL LP 1 139 ...	13.90	3.00	9.20
SL LP 1 097 ...	9.70	3.00	5.00	SL LP 1 164 ...	16.40	3.00	11.70
SL LP 1 112 ...	11.20	3.00	6.50	SL LP 1 190 ...	19.00	3.00	14.30

please indicate: ... no. of contacts one row 1-36 ... surface S = selective gold-plated G = gold-plated Z = tin-plated

two rows, □ 0.635 mm

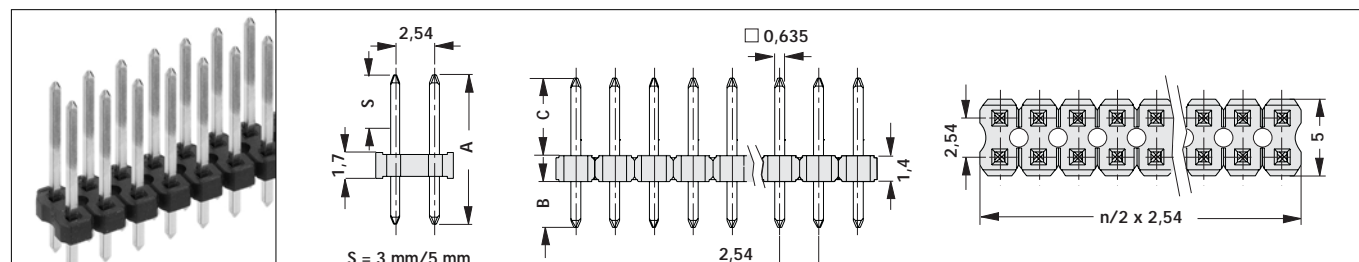

art. no.	dim. [mm]			art. no.	dim. [mm]		
	A	B	C		A	B	C
SL LP 2 082 ...	8.20	3.00	3.50	SL LP 2 139 ...	13.90	3.00	9.20
SL LP 2 097 ...	9.70	3.00	5.00	SL LP 2 164 ...	16.40	3.00	11.70
SL LP 2 112 ...	11.20	3.00	6.50	SL LP 2 190 ...	19.00	3.00	14.30

please indicate: ... no. of contacts two rows 2-72 ... surface S = selective gold-plated G = gold-plated Z = tin-plated

Every pin length is available on request.

Male headers soldering technique

Low profile, angled

one row, □ 0.635 mm

art. no.	dim. [mm]			art. no.	dim. [mm]		
	A	B	C		A	B	C
SL LP 3 041 ...	4.50	3.00	4.10	SL LP 3 069 ...	4.50	3.00	6.90

please indicate: ... no. of contacts one row 1-36 ... surface
 S = selective gold-plated
 G = gold-plated
 Z = tin-plated

two rows, □ 0.635 mm

art. no.	dim. [mm]			art. no.	dim. [mm]		
	A	B	C		A	B	C
SL LP 4 041 ...	4.50	3.00	4.10	SL LP 4 069 ...	4.50	3.00	6.90

please indicate: ... no. of contacts two rows 2-72 ... surface
 S = selective gold-plated
 G = gold-plated
 Z = tin-plated

Every pin length is available on request.

0.635 mm, Sandwich

art. no.	dim. [mm]	art. no.	dim. [mm]	art. no.	dim. [mm]
	A L		A L		A L
SL 5 071 ...	7.10 16.40	SL 5 223 ...	22.30 31.60		
SL 5 097 ...	9.70 19.00	SL 5 237 ...	23.70 33.00		
SL 5 121 ...	12.10 21.40	SL 5 285 ...	28.50 37.80		
SL 5 147 ...	14.70 24.00	SL 5 315 ...	31.50 40.80		
SL 5 156 ...	15.60 24.90	SL 5 360 ...	36.00 45.30		
SL 5 172 ...	17.20 26.50	SL 5 415 ...	41.50 50.80		
SL 5 197 ...	19.70 29.00	SL 5 525 ...	52.20 61.50		
art. no.	dim. [mm]	art. no.	dim. [mm]	art. no.	dim. [mm]
	A L		A L		A L
SL 6 071 ...	7.10 16.40	SL 6 223 ...	22.30 31.60		
SL 6 097 ...	9.70 19.00	SL 6 237 ...	23.70 33.00		
SL 6 121 ...	12.10 21.40	SL 6 285 ...	28.50 37.80		
SL 6 147 ...	14.70 24.00	SL 6 315 ...	31.50 40.80		
SL 6 156 ...	15.60 24.90	SL 6 360 ...	36.00 45.30		
SL 6 172 ...	17.20 26.50	SL 6 415 ...	41.50 50.80		
SL 6 197 ...	19.70 29.00	SL 6 525 ...	52.20 61.50		
please indicate:	... no. of contacts	... surface			
	one row 1-36	S = selective gold-plated			
	two rows 2-72	G = gold-plated			
		Z = tin-plated			

"S" selective gold-plated to 33.0 mm pin length

For interconnections of stacked PCBs. Within the total length the insulator position can be changed as required. ... Design specification. V-notches permit breaking! Therefore any required number of contacts is available.

- | | | | |
|------------------------------------|-------------|-------------------------------------|-------------|
| IDC-connectors | → H 1 - 14 | Jumpers | → G 77 - 78 |
| Technical data | → G 75 - 80 | Female headers 2.54 SMD | → G 46 - 49 |
| High-prec. fem. headers 2.54 sold. | → G 31 - 34 | Fem. head. 2.54 solder, put through | → G 29 |
| Special male & female headers | → G 19 | Female headers 2.54 solder | → G 27 |

Male headers soldering technique

□ 0,635 mm, Sandwich

art. no.	dim. [mm]	art. no.	dim. [mm]
	A L		A L
SL 13 071 ...	7.10 21.40	SL 13 235 ...	23.50 37.80
SL 13 097 ...	9.70 24.00	SL 13 265 ...	26.50 40.80
SL 13 122 ...	12.20 26.50	SL 13 310 ...	31.00 45.30
SL 13 147 ...	14.70 29.00	SL 13 365 ...	36.50 50.80
SL 13 187 ...	18.70 33.00		
art. no.	dim. [mm]	art. no.	dim. [mm]
	A L		A L
SL 14 071 ...	7.10 21.40	SL 14 235 ...	23.50 37.80
SL 14 097 ...	9.70 24.00	SL 14 265 ...	26.50 40.80
SL 14 122 ...	12.20 26.50	SL 14 310 ...	31.00 45.30
SL 14 147 ...	14.70 29.00	SL 14 365 ...	36.50 50.80
SL 14 187 ...	18.70 33.00		
please indicate:	... no. of contacts one row 1-36 two rows 2-72	... surface S = selective gold-plated G = gold-plated Z = tin-plated	

"S" selective gold-plated to 33.0 mm pin length

For interconnections of stacked PCBs. The male headers SL 13 and SL 14 are used to connect BL 11 (SL 13 ...) and BL 12 (SL 14 ...). Suitable for PCBs 1.5 mm - 3.0 mm thick.

V-notches permit breaking! Therefore any required number of contacts is available. Every pin length is available on request.



A

B

C

D

E

F

G

H

I

K

L

M

N

Empty page

Male headers soldering technique

Shroud male header, with coding, boltable

suitable for many flat cable connectors in 2.54 mm pitch

art. no.	no. of contacts	dim. [mm]		
		A	B	C
SLU 10 ...	10	20.40	17.80	10.16
SLU 16 ...	16	28.00	25.40	17.78
SLU 20 ...	20	33.10	30.50	22.86
SLU 26 ...	26	40.70	38.10	30.48
SLU 40 ...	40	58.50	55.90	48.26
SLU 50 ...	50	71.20	68.60	60.96
please indicate:	... surface	... height "E"		
	S = selective gold-plated	165		
	Z = tin-plated	191		
		241		
		266		
height "E"		dim. [mm]		
		D	E (max.)	
165		13.50	16.50	
191		16.10	19.10	
241		21.10	24.10	
266		23.60	26.60	

Three rows, □ 0.635 mm - standard

straight

art. no.	dim. [mm]			art. no.	dim. [mm]		
	A	B	C		A	B	C
SL KG 3 113 ...	11.30	3.30	5.50	SL KG 3 147 ...	14.70	3.30	8.90
SL KG 3 126 ...	12.60	3.30	6.80				
please indicate:	... no. of contacts three rows 3-150			... surface G=gold-plated Z=tin-plated			

angled

art. no.	dim. [mm]			art. no.	dim. [mm]		
	A	B	C		A	B	C
SL KA 3 072 ...	7.20	3.30	3.40	SL KA 3 108 ...	10.80	3.30	7.00
SL KA 3 085 ...	8.50	3.30	4.70				
please indicate:	... no. of contacts three rows 3-150			... surface G=gold-plated Z=tin-plated			

A



B

Empty page

C

D

E

F

G

H

I

K

L

M

N

Grid spacing 2.54 mm, □ 0.635 mm

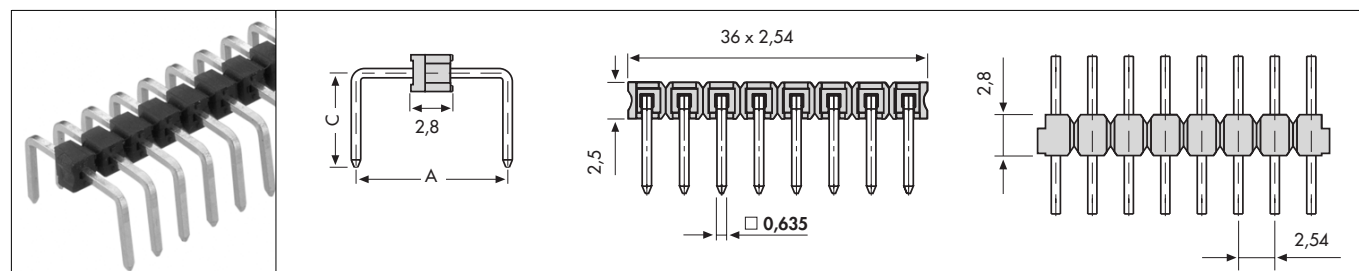

art. no.	dim. [mm]	
	A	C
LB SL 0508 ...	5.08	6.10
LB SL 0762 ...	7.62	6.10
LB SL 1016 ...	10.16	6.10
LB SL 1524 ...	15.24	6.10
please indicate:	... surface G = gold-plated Z = tin-plated	

Grid spacing 2.00 mm, □ 0.5 mm

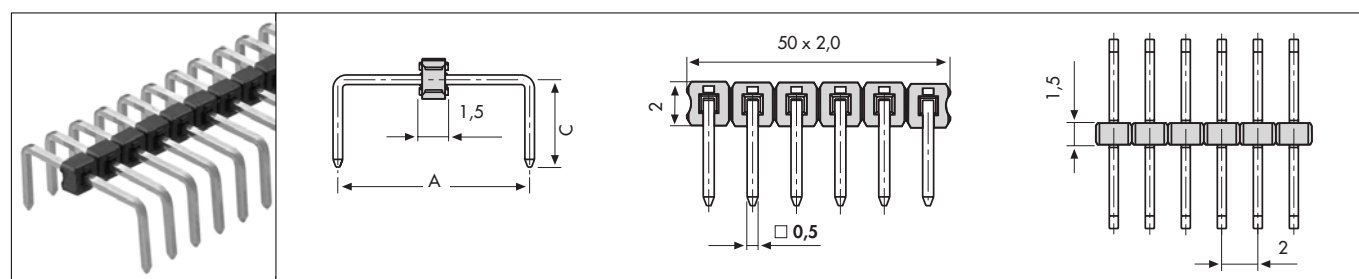

art. no.	dim. [mm]	
	A	C
LB SLY 06 ...	6.00	4.50
please indicate:	... surface G = gold-plated Z = tin-plated	

Dimension "A" available in 4 versions. Dimension "C" variable (on request).
 Jumper links are also available in grid spacing 1.27 mm.

V-notches permit breaking! Therefore any required number of contacts is available.

High-precision female headers soldering technique

for Ø 0.5 mm

art. no.			art. no.		
MK 01 ...			MK 201 ...		
art. no.			art. no.		
MK 17 ...			MK 217 ...		
art. no.			art. no.		
MK 12 X 2 ...			MK 212 X 2 ...		
art. no.			art. no.		
MK 13 X 1 ...	X		MK 213 X 1 ...	X	
MK 13 X 2 ...	5.9		MK 213 X 2 ...	5.9	
	8.9			8.9	
please indicate:	... no. of contacts	... surface			
	one row 1-50	G=gold-plated			
	two rows 2-100	Z=tin-plated			

contact spring: gold-plated

High-precision female headers soldering technique

Low profile, less than 2.7/3.1 mm above P.C.B. - with contact spring for Ø 0.5 mm pins

solder and plug pin Ø 0.76 mm

art. no.			art. no.		
MK LP 18 ...			MK LP 218 ...		
art. no.			art. no.		
MK LP 19 ...			MK LP 219 ...		
please indicate:	... no. of contacts one row 1-50 two rows 4-100		... surface G=gold-plated Z=tin-plated		

contact spring: gold-plated

Low profile: 2.7/3.1 mm above P.C.B.; standard profile: 4 mm

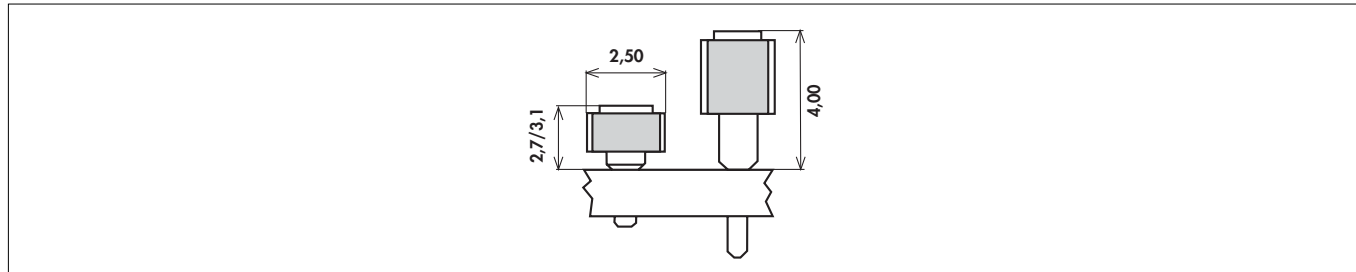

Single in-line carrier

art. no.			
SIL 1 ...		99x2,54=251,46 max. 17,5 3,8 0,8 2x2,54=5,08 min.	∅ 1,8 ∅ 1,5 3,83 0,75 ∅ 1,35
art. no.			
SIL 2 ...		99x2,54=251,46 max. 21,15 7,54 0,8 3,58 2x2,54=5,08 min.	∅ 1,8 1,6 0,75 7,4 3,9 ∅ 1,55 ∅ 1,35 ∅ 0,5
art. no.			
SIL 3 ...		99x2,54=251,46 max. 31,6 17,9 0,8 4,9 2x2,54=5,08 min.	∅ 1,8 ∅ 1,5 0,75 4,9 13,08 0,7 ∅ 1,5 ∅ 1,35 □ 0,635
please indicate:	... no. of contacts one row 2-100	... surface G=gold-plated Z=tin-plated	

contact spring: gold-plated

Female headers soldering technique

Stamped contact spring (fork contact)

for □ 0.635 mm, straight

art. no.				
BL 1 ...				
art. no.				
BL 2 ...				
please indicate:	... no. of contacts one row 1-36 two rows 2-72		... surface G=gold-plated Z=tin-plated	

V-notches permit breaking! Therefore any required number of contacts is available.

for □ 0.635 mm, angled

art. no.				
BL 3 ...				
art. no.				
BL 4 ...				
please indicate:	... no. of contacts one row 1-36 two rows 2-72		... surface G=gold-plated Z=tin-plated	

V-notches permit breaking! Therefore any required number of contacts is available.

BL 4 ...: packing (option) bar magazine (min. 6 contacts)

Female headers soldering technique

Low profile, fork contact

for □ 0.635 mm, straight

<p>art. no.</p> <p>BL LP 1 ...</p>				
<p>art. no.</p> <p>BL LP 2 ...</p>				
<p>art. no.</p> <p>BL LP 3 ...</p>				
<p>art. no.</p> <p>BL LP 4 ...</p>				
<p>please indicate: ... no. of contacts one row 1-36 two rows 2-72</p> <p> ... surface S = selective gold-plated Z = tin-plated</p>				

V-notches permit breaking! Therefore any required number of contacts is available.

BL LP 4 ...: packing (option) bar magazine (min. 6 contacts)

A

B

C

D

E

F

G

H

I

K

L

M

N

Female headers soldering technique

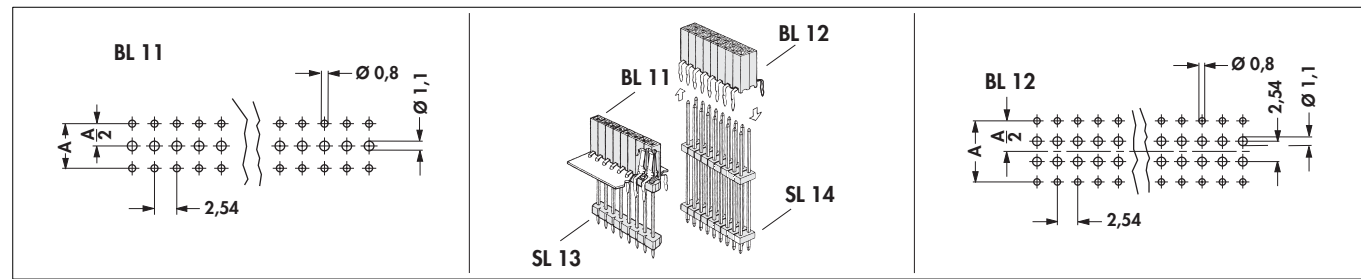

for □ 0.635 mm, can be put through from above or below / 260 °C Reflow

art. no.	dim. [mm]
BL 11 254 ...	A 2.54
BL 11 508 ...	A 5.08

please indicate: ... no. of contacts one row 1-45 ... surface S = selective gold-plated Z = tin-plated

packed: bar magazine
Stamped contact spring.
Can be cut! Every desired number of contacts can be delivered.

for □ 0,635 mm, can be put through from above or below

art. no.	dim. [mm]
BL 12 650 ...	A 6.50
BL 12 762 ...	A 7.62

please indicate: ... no. of contacts two rows 2-90 ... surface S = selective gold-plated Z = tin-plated

packed: bar magazine
Stamped contact spring.
Can be cut! Every desired number of contacts can be delivered.

Female headers soldering technique

for \square 0,635 mm, can be put through from above

art. no.	dim. [mm]		
	A		
BL 21 650 ...	6.50		
BL 21 762 ...	7.62		
please indicate:	... no. of contacts two rows 2-64	... surface S = selective gold-plated Z = tin-plated	

packed: bar magazine

Stamped contact spring.

Can be cut! Every desired number of contacts can be delivered.

A

B

C

D

E

F

G

H

I

K







L

M

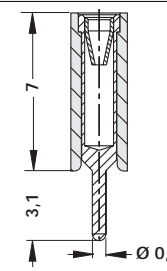
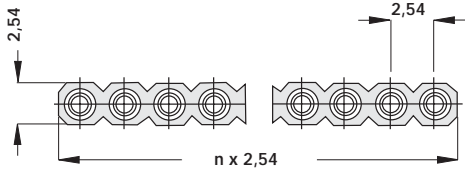
N

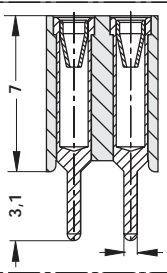
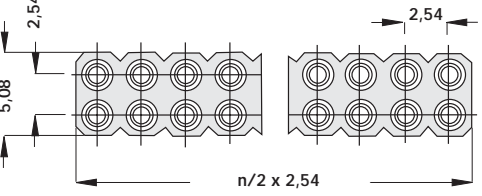
High-precision female headers soldering technique

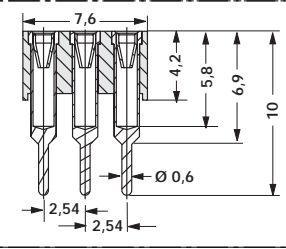
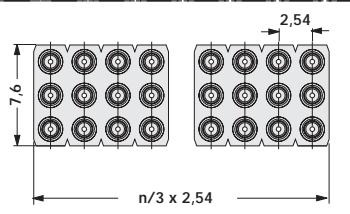
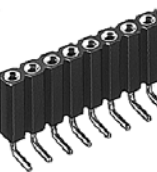
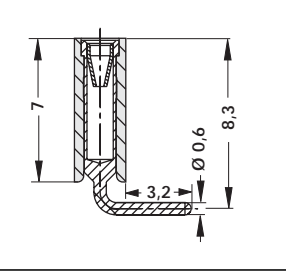
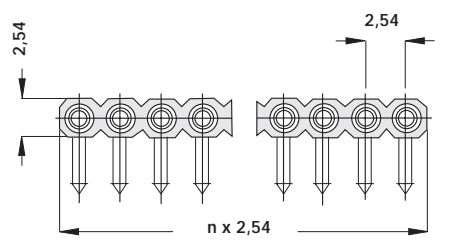
for □ 0.635 mm and up to 0.85 mm Ø

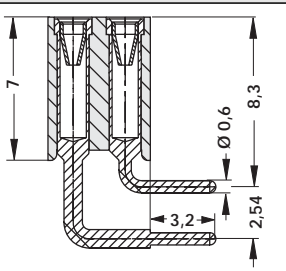
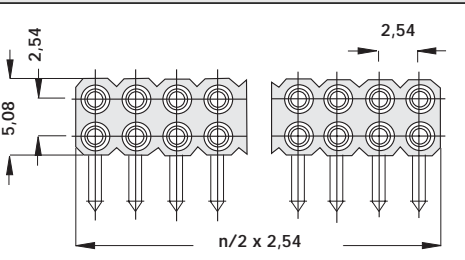
<p>art. no.</p> <p>BL 5 ...</p>		 <p>7 3,1 Ø 0,6</p>	 <p>2,54 2,54 n x 2,54</p>
<p>art. no.</p> <p>BL 6 ...</p>		 <p>7 3,1 Ø 0,6</p>	 <p>2,54 5,08 2,54 n/2 x 2,54</p>
<p>art. no.</p> <p>BL KG 3 ...</p>		 <p>7,6 4,2 5,8 6,9 10 Ø 0,6 2,54 2,54</p>	 <p>2,54 7,6 n/3 x 2,54</p>
<p>art. no.</p> <p>BL 7 ...</p>		 <p>7 3,2 Ø 0,6 8,3</p>	 <p>2,54 2,54 n x 2,54</p>
<p>please indicate:</p>		<p>... no. of contacts</p> <p>one row 1-36</p> <p>two rows 2-72</p> <p>three rows 9-96</p>	
<p>art. no.</p> <p>BL 8 ...</p>		 <p>7 3,2 Ø 0,6 8,3 2,54</p>	 <p>2,54 5,08 2,54 n/2 x 2,54</p>
<p>please indicate:</p>		<p>... no. of contacts</p> <p>two rows 4-72</p>	

contact shell surface: tin-plated

contact spring: gold-plated

BL 8 ...: packing (option) bar magazine (min. 6 contacts)

No capillary action when soldering due to protected contact insert.

V-notches permit breaking! Therefore any required number of contacts is available.

High-precision female headers soldering technique

for \square 0.635 mm and up to 0.85 mm \varnothing

<p>art. no.</p> <p>MK 21 ...</p>	
<p>art. no.</p> <p>MK 221 ...</p>	
<p>please indicate: ... no. of contacts</p> <p>one row 1-50</p> <p>two rows 2-100</p>	

contact shell surface: tin-plated

contact spring: gold-plated

No capillary action when soldering due to protected contact insert.

V-notches permit breaking! Therefore any required number of contacts is available.

A

High-precision female headers soldering technique

B

for \square 0.635 mm and up to 0.85 mm \varnothing

with aligned contact pin

C

art. no. BL 9 ...		
art. no. BL 10 ...		
please indicate: ... no. of contacts one row 1-36 two rows 2-72		

D

E

F

contact shell surface: tin-plated

contact spring: gold-plated

No capillary action when soldering due to protected contact insert.

V-notches permit breaking! Therefore any required number of contacts is available.

G

for PC 104 modules

H

I

K

L

art. no. BL 13 ...		
art. no. BL 14 ...		
please indicate: ... no. of contacts one row 1-36 two rows 2-72		

M

contact shell surface: gold-plated

contact spring: gold-plated

No capillary action when soldering due to protected contact insert.

V-notches permit breaking! Therefore any required number of contacts is available.

N

G 33
Male headers 2.00 solder
High-precision female headers
Male headers 2.54 solder
Male headers 2.54 SMD

 → G 56 - 58
 → G 3 - 5
 → G 8
 → G 37 - 42

Female headers 2.00 solder
Female headers 2.00 SMD
Technical data

 → G 60
 → G 64
 → G 75 - 80

High-precision female headers soldering technique

for □ 0.635 mm and up to 0.85 mm Ø - for PC 104 modules

one row, 1-36 contacts

art. no.	dim. [mm] A
BL 18 141 ...	14.10
BL 18 219 ...	21.90
please indicate:	... no. of contacts one row 1-36

two rows, 2-72 contacts

art. no.	dim. [mm] A
BL 19 141 ...	14.10
BL 19 219 ...	21.90
please indicate:	... no. of contacts two rows 2-72

contact shell surface and contact spring: gold-plated

No capillary action when soldering due to protected contact insert.
V-notches permit breaking! Therefore any required number of contacts is available.

High-precision male headers in SMD mounting

<p>art. no.</p> <p>MK 26 SMD ...</p>					
<p>please indicate: ... no. of contacts one row 4-20</p> <p>... surface G = gold-plated Z = tin-plated</p> <p>... packing (option) SM = bar magazine B SM = pick and place pad and bar magazine</p>					
<p>art. no.</p> <p>MK 226 SMD ...</p>					
<p>please indicate: ... no. of contacts two rows 4-40</p> <p>... surface G = gold-plated Z = tin-plated</p> <p>... packing (option) SM = bar magazine 6 pol. B SM = pick and place pad and bar magazine</p>					

... packing (option) - additions: MK 226 SMD ... SM and ... B SM: 6-40 contacts

For further informations please see "for automatic assembly" following this series!

<p>art. no.</p> <p>MK 27 SMD ...</p>					
<p>please indicate: ... no. of contacts one row 2-20</p> <p>... surface G = gold-plated Z = tin-plated</p>					



2.54

Empty page

A

B

C

D

E

F

G

H

I

K

L

M

N

Male headers in SMD mounting

□ 0.635 mm

art. no.	dim. [mm] C			
SL 10 SMD 040 ...	4.00			
SL 10 SMD 052 ...	5.50			
SL 10 SMD 062 ...	6.70			
SL 10 SMD 078 ...	8.20			
SL 10 SMD 104 ...	10.80			
SL 10 SMD 130 ...	13.40			
please indicate:	<table border="0"> <tr> <td>... no. of contacts one row 4-20</td> <td>... surface S = sel. gold-plated G = gold-plated Z = tin-plated</td> <td>... packing (option) SM = bar magazine B SM = pick and place pad and bar magazine B TR = pick and place pad and tape and reel (250 pcs/reel)</td> </tr> </table>	... no. of contacts one row 4-20	... surface S = sel. gold-plated G = gold-plated Z = tin-plated	... packing (option) SM = bar magazine B SM = pick and place pad and bar magazine B TR = pick and place pad and tape and reel (250 pcs/reel)
... no. of contacts one row 4-20	... surface S = sel. gold-plated G = gold-plated Z = tin-plated	... packing (option) SM = bar magazine B SM = pick and place pad and bar magazine B TR = pick and place pad and tape and reel (250 pcs/reel)		

art. no.	dim. [mm] C			
SL 11 SMD 040 ...	4.00			
SL 11 SMD 052 ...	5.50			
SL 11 SMD 062 ...	6.70			
SL 11 SMD 078 ...	8.20			
SL 11 SMD 104 ...	10.80			
SL 11 SMD 130 ...	13.40			
please indicate:	<table border="0"> <tr> <td>... no. of contacts two rows 4-40</td> <td>... surface S = sel. gold-plated G = gold-plated Z = tin-plated</td> <td>... packing (option) SM = bar magazine B SM = pick and place pad and bar magazine B TR = pick and place pad and tape and reel (250 pcs/reel)</td> </tr> </table>	... no. of contacts two rows 4-40	... surface S = sel. gold-plated G = gold-plated Z = tin-plated	... packing (option) SM = bar magazine B SM = pick and place pad and bar magazine B TR = pick and place pad and tape and reel (250 pcs/reel)
... no. of contacts two rows 4-40	... surface S = sel. gold-plated G = gold-plated Z = tin-plated	... packing (option) SM = bar magazine B SM = pick and place pad and bar magazine B TR = pick and place pad and tape and reel (250 pcs/reel)		

... packing (option) - additions:

SL 10 SMD 052-104 SM; ... B SM, 4-20 contacts

SL 10 SMD 052-078 B TR, 4-12 contacts

SL 11 SMD 052-104 SM; ... B SM, 6-40 contacts

G 37

Male headers 2.54 solder
Male headers 2.00 SMD
Single contacts metal strip
Technical data

→ G 8
→ G 61 - 62
→ G 26
→ G 75 - 80

High-prec. fem. headers 2.54 sold.
Female headers 2.00 SMD
Female headers 2.54 press-fit
Jumpers

→ G 31 - 34
→ G 64
→ G 53
→ G 77 - 78

**Male headers in SMD mounting**

SL 11 SMD 052-078 ...: ... B TR, 6-24 contacts

For further informations please see "for automatic assembly" following this series!

A

B

C

D

E

F

G

H

I

K

L

M

Male headers 2.54 solder
Male headers 2.00 SMD
Single contacts metal strip
Technical data

→ G 8
→ G 61 - 62
→ G 26
→ G 75 - 80

High-prec. fem. headers 2.54 sold.
Female headers 2.00 SMD
Female headers 2.54 press-fit
Jumpers

→ G 31 - 34
→ G 64
→ G 53
→ G 77 - 78

G 38

N

Male headers in SMD mounting

□ 0.635 mm

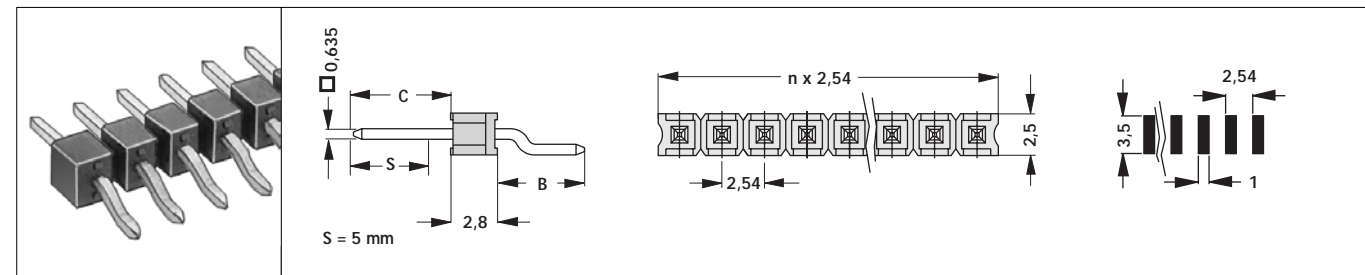

art. no.	surface	dim. [mm]	
		B	C
SL 12 SMD 031 ...	S/ G/ Z	5.20	3.10
SL 12 SMD 032 ...	G/ Z	3.20	5.80
SL 12 SMD 058 ...	S/ G/ Z	5.20	5.80
SL 12 SMD 083 ...	S/ G/ Z	5.20	8.30
SL 12 SMD 109 ...	S/ G/ Z	5.20	10.90

please indicate: ... no. of contacts one row 2-20 ... surface S = sel. gold-plated G = gold-plated Z = tin-plated ... packing (option) B SM = pick and place pad and bar magazine B TR = pick and place pad and tape and reel (500 pcs/reel)

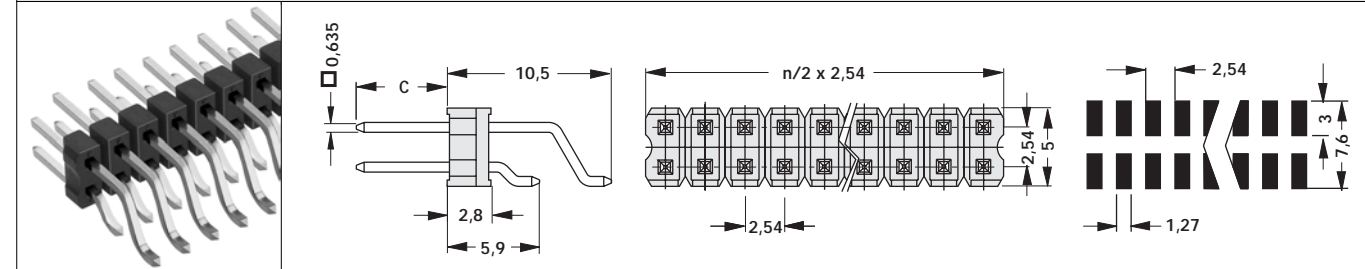

art. no.	dim. [mm]	
	C	
SL 17 SMD 058 ...	5.80	
SL 17 SMD 083 ...	8.30	
SL 17 SMD 109 ...	10.90	

please indicate: ... no. of contacts two rows 4-40 ... surface G = gold-plated Z = tin-plated ... packing (option) B SM = pick and place pad and bar magazine B TR = pick and place pad and tape and reel (300 pcs/reel)

... packing (option) - additions:

- SL 12 SMD ... B TR: 2-13 contacts
- SL 17 SMD ... B TR: 6-24 contacts

For further informations please see "for automatic assembly" following this series!

Male headers in SMD mounting

Low profile in SMD □ 0.635 mm

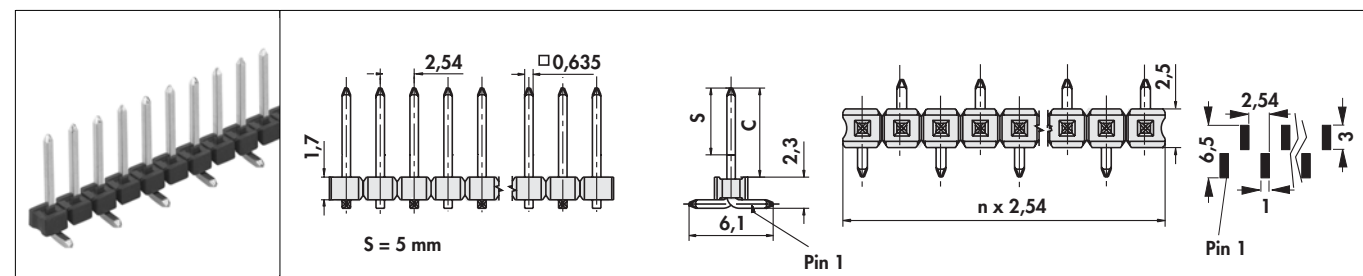

art. no.	dim. [mm]	art. no.	dim. [mm]
	C		C

SL LP 5 SMD 038 ...	3.80	SL LP 5 SMD 066 ...	6.60
---------------------	------	---------------------	------

SL LP 5 SMD 051 ...	5.10		
---------------------	------	--	--

please indicate: ... no. of contacts one row 4-20

... surface
 S = sel. gold-plated
 G = gold-plated
 Z = tin-plated

... packing (option)
 SM = bar magazine
 B SM = pick and place pad and bar magazine
 B TR = pick and place pad and tape and reel (250 pcs/reel)

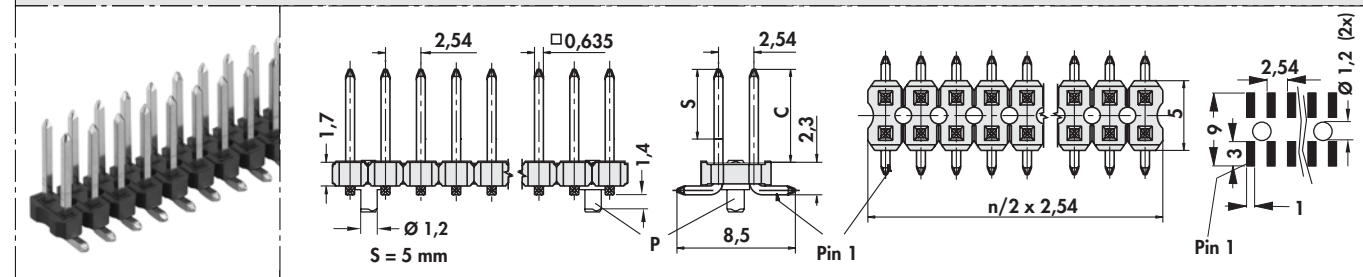

art. no.	dim. [mm]	art. no.	dim. [mm]
	C		C

SL LP 6 SMD 038 ...	3.80	SL LP 6 SMD 066 ...	6.60
---------------------	------	---------------------	------

SL LP 6 SMD 051 ...	5.10		
---------------------	------	--	--

please indicate: ... no. of contacts two rows 4-40

... surface
 S = sel. gold-plated
 G = gold-plated
 Z = tin-plated

... packing (option)
 SM = bar magazine
 B SM = pick and place pad and bar magazine
 B TR = pick and place pad and tape and reel (250 pcs/reel)

... position (option)
 PS = locating pin (2 pcs/bar bigger than 6 contacts)

... packing (option) - additions:

SL LP 5 SMD ...: ... SM; ... B SM; 4-20 contacts
 SL LP 5 SMD ...: ... B TR, 4-12 contacts

SL LP 6 SMD ...: ... SM; ... B SM; 6-40 contacts
 SL LP 6 SMD ...: ... B TR, 6-24 contacts

For further informations please see "for automatic assembly" following this series!

A



2.54

Male headers in SMD mounting

B

Empty page

C

D

E

F

G

H

I

K

L

M

N

□ 0.635 mm – for interconnections of stacked PCBs

one row, 4-20 contacts

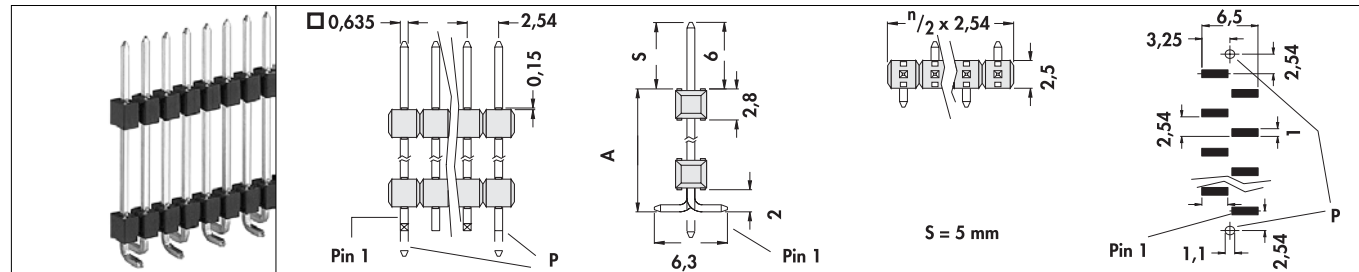

art. no.	dim. [mm]
	A
SL 15 SMD 107 ...	10.70
SL 15 SMD 182 ...	18.20
SL 15 SMD 207 ...	20.70

please indicate: ... no. of contacts one row 4-20 ... surface S = sel. gold-plated G = gold-plated Z = tin-plated ... position (option) P = end pins straight for positioning

A

High-precision female headers in SMD mounting

for □ 0.635 mm and up to 0.85 mm Ø

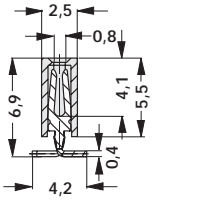
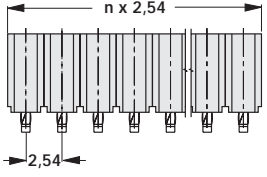
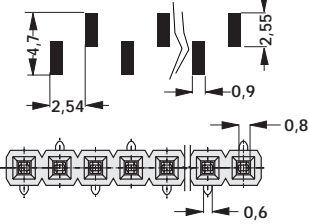
art. no. BL LP 5 SMD ...				
please indicate:		... no. of contacts one row 4 - 20		... packing (option) SM = bar magazine B SM = pick and place pad and bar magazine B TR = pick and place pad and tape and reel (250 pcs/reel)

D

E

F

G

H

I

K

L

M

N

A



High-precision female headers in SMD mounting

B

C

D

E

F

G

H

I

K

L

M

N

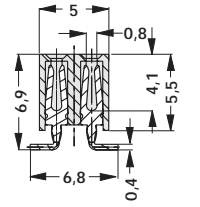
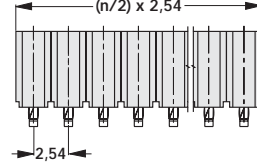
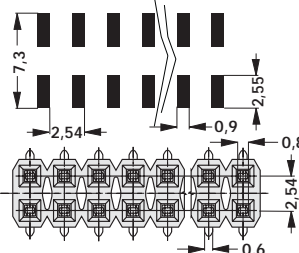
<p>art. no.</p>				
<p>BL LP 6 SMD ...</p> <p>please indicate:</p>		<p>... no. of contacts two rows 4-40</p>	<p>... packing (option)</p> <p>SM = bar magazine</p> <p>B SM = pick and place pad and bar magazine</p> <p>B TR = pick and place pad and tape and reel (250 pcs/reel)</p>	

High-precision female headers in SMD mounting

for □ 0.635 mm and up to 0.85 mm Ø

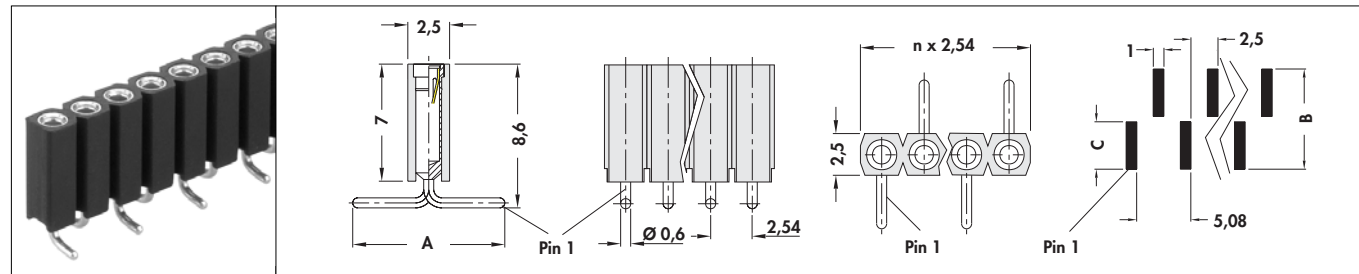

art. no.	dim. [mm]		
	A	B	C
BL 15 SMD 043...	4.30	5.00	2.50
BL 15 SMD 089...	8.90	9.50	4.80

please indicate: ... no. of contacts one row 4-20 ... packing (option) SM = bar magazine B SM = pick and place pad and bar magazine

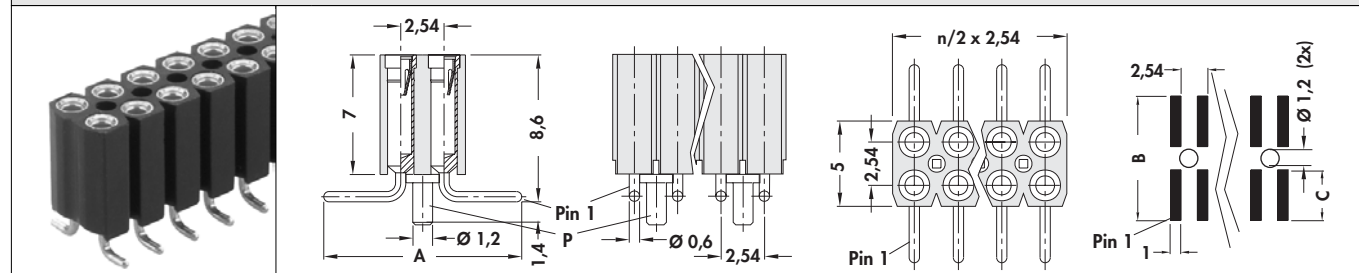

art. no.	dim. [mm]		
	A	B	C
BL 16 SMD 067 ...	6.70	7.50	2.50
BL 16 SMD 113 ...	11.30	12.00	4.80

please indicate: ... no. of contacts two rows 4-40 ... packing (option) SM = bar magazine B SM = pick and place pad and bar magazine B TR = pick and place pad and tape and reel (250 pcs/reel) ... position (option) PS = locating pin (2 pcs/bar bigger than 6 contacts)

contact shell surface: tin-plated

contact spring: gold-plated

No capillary action when soldering due to protected contact insert.
V-notches permit breaking! Therefore any required number of contacts is available.

... packing (option) - additions:

BL 16 SMD ... B TR: 6-24 contacts

For further informations please see "for automatic assembly" following this series!

- Female headers 1.27 SMD → G 74
- Female headers 2.00 SMD → G 64
- Female headers 2.54 press-fit → G 53
- Fem. head. 2.54 solder, put through → G 29

- Technical data → G 75 - 80
- Male headers 2.54 solder → G 8
- Male headers 2.54 SMD → G 37 - 42

G 46

A

B

C

D

E

F

G

H

I

K

L

M

N

High-precision female headers in SMD mounting

for □ 0.635 mm and up to 0.85 mm Ø

<p>art. no.</p> <p>BL 17 SMD ...</p>		
<p>art. no.</p> <p>BL 20 SMD ...</p>		
<p>please indicate: ... no. of contacts one row 2-20 two rows 4-40</p> <p> ... packing (option) SM = bar magazine</p>		
<p>art. no.</p> <p>MK 22 SMD ...</p>		
<p>art. no.</p> <p>MK 222 SMD ...</p>		
<p>please indicate: ... no. of contacts one row 4-20 two rows 4-40</p> <p> ... packing (option) B SM =pick and place pad and bar magazine</p>		
<p>art. no.</p> <p>MK 24 SMD ...</p>		
<p>please indicate: ... no. of contacts one row 2-20</p>		

contact shell surface: tin-plated; contact spring: gold-plated
 No capillary action when soldering due to protected contact insert.

... packing (option) - additions:

BL 17 SMD ... SM: 5-20 contacts; BL 20 SMD ... SM: 10-40 contacts

For further informations please see "for automatic assembly" following this series!



2.54

Empty page

A

B

C

D

E

F

G

H

I

K

L

M

G 48

N

High-precision female headers in SMD mounting

for Ø 0.5 mm

one and two rows

<p>art. no.</p> <p>MK 23 SMD ...</p>			
<p>art. no.</p> <p>MK 223 SMD ...</p>			
<p>please indicate: ... no. of contacts one row 4-20 two rows 4-40</p> <p> ... packing (option) B SM = pick and place pad and bar magazine</p>			

Two row

<p>art. no.</p> <p>MK 220 SMD ...</p>			
<p>please indicate: ... no. of contacts two rows 4-40</p> <p> ... packing (option) B SM = pick and place pad and bar magazine B TR = pick and place pad and tape and reel (4-12 contacts 800 pcs/reel, 4-12 contacts; 14-40 contacts 500 pcs/reel)</p>			

For further informations please see "for automatic assembly" following this series!

one row

<p>art. no.</p> <p>MK 25 SMD ...</p>			
<p>please indicate: ... no. of contacts one row 2-20</p>			

contact shell surface: tin-plated

contact spring: gold-plated



2.54

Empty page

A

B

C

D

E

F

G

H

I

K

L

M

G 50

N

Connectors in press-fit mounting

Male connectors

one row, 1-36 contacts, for PCB thickness ≥ 1.6 mm dimension B = 3.5 mm and ≥ 3.0 mm dimension B = 4.5 mm

art. no.	dim. [mm]		
	A	B	C
SLP 1 16 117 ...	11.70	3.50	5.40
SLP 1 16 129 ...	12.90	3.50	6.60
SLP 1 16 144 ...	14.40	3.50	8.10
SLP 1 16 195 ...	19.50	3.50	13.20
SLP 1 32 139 ...	13.90	4.50	6.60
SLP 1 32 164 ...	16.40	4.50	9.10

please indicate: ... no. of contacts one row 1-36 ... surface G=gold-plated Z=tin-plated

two rows, 2-72 contacts, for PCB thickness ≥ 1.6 mm dimension B = 3.5 mm and ≥ 3.0 mm dimension B = 4.5 mm

art. no.	dim. [mm]		
	A	B	C
SLP 2 16 117 ...	11.70	3.50	5.40
SLP 2 16 129 ...	12.90	3.50	6.60
SLP 2 16 144 ...	14.40	3.50	8.10
SLP 2 16 195 ...	19.50	3.50	13.20
SLP 2 32 139 ...	13.90	4.50	6.60
SLP 2 32 164 ...	16.40	4.50	9.10

please indicate: ... no. of contacts two rows 2-72 ... surface G=gold-plated Z=tin-plated

contact material: Cu Sn 6

Press-fit mounting without soldering, resilient press-fit area, easy insertion into PCB. V-notches permit breaking!
Any required number of contacts available.

PCB layout please see BLP ...

Male header with shroud

suitable for boltable female header VFL, can be combined with many other female headers with grid spacing 2,54 mm (e. g.: PV, BL)

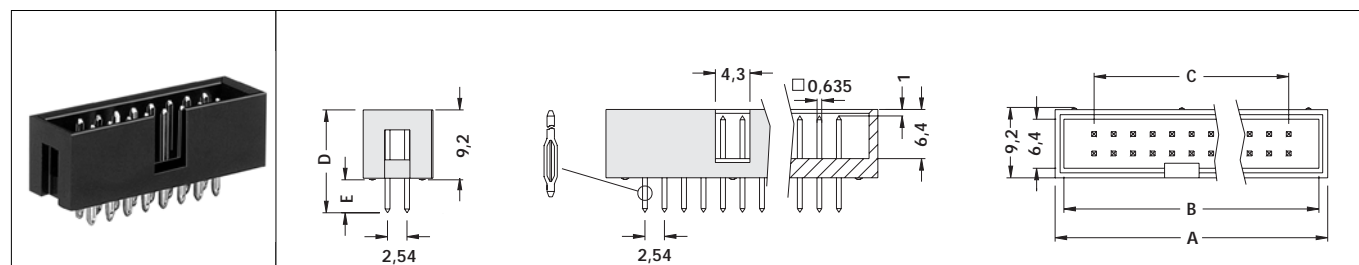

art. no.	no. of contacts	dim. [mm]				
		A	B	C	D	E (max.)
SLUP 31 10 ...	10	20.40	17.80	10.16	12.60	3.50
SLUP 31 16 ...	16	28.00	25.40	17.78	12.60	3.50
SLUP 31 20 ...	20	33.10	30.50	22.86	12.60	3.50

please indicate: ... surface
G = gold-plated
Z = tin-plated

contact material: Cu Sn 6

Press-fit mounting without soldering, resilient press-fit area, easy insertion into PCB.

PCB layout please see BLP ...

Connectors in press-fit mounting

High-precision female headers □ 0,635 mm and pins up to 0,85 mm Ø

Press-fit mounting without soldering, resilient press-fit area.

<p>art. no.</p> <p>BLP 1 ...</p>			
<p>art. no.</p> <p>BLP 2 ...</p>			
<p>please indicate:</p>		<p>... no. of contacts one row 1-36 two rows 2-72</p>	

contact-insert: gold-plated

contact shell: tin-plated

V-notches permit breaking! Therefore any required numbers of contacts are available.

Hole diameter in PCB - PCB hole structure acc. to DIN EN 60352-5

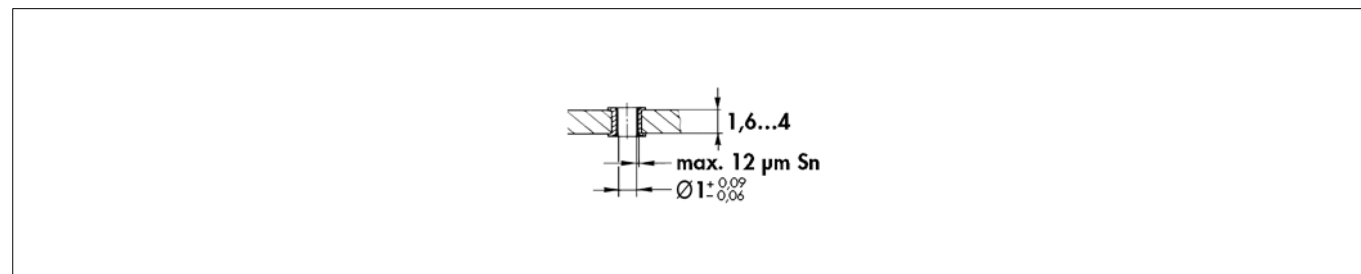

Direct female connector

Without short circuit contact for PCB thickness: 0.7-0.9 mm

for removable connection of digital displays, coding switches, impulse counters

<p>art. no.</p> <p>DF 1 OK 9 Z</p>				
<p>art. no.</p> <p>DF 2 OK 9 Z</p>				

With short circuit contact for PCB thickness: 0.7-0.9 mm

for removable connection of digital displays, coding switches, impulse counters

<p>art. no.</p> <p>DF 1 MK 9 Z</p>				
<p>art. no.</p> <p>DF 2 MK 9 Z</p>				

K* = arcing contact

A

Direct female connector

for PCB thickness: 1.4-1.8 mm

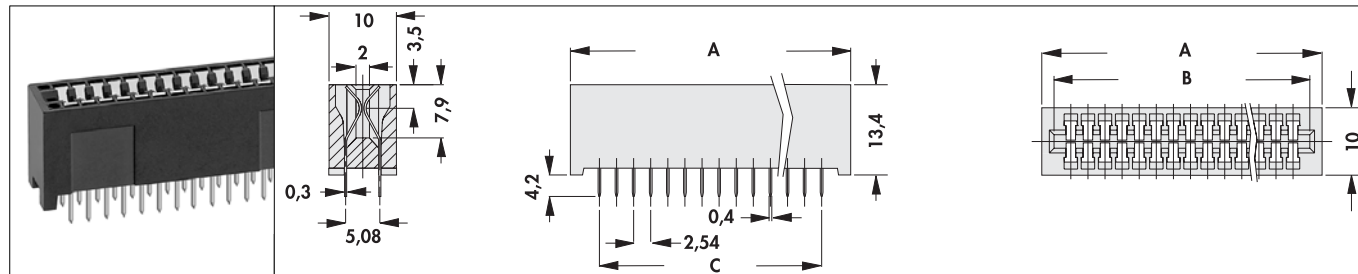

art. no.	no. of contacts	dim. [mm]		
		A	B	C
DF OB 06	12	21.33	17.70	12.70
DF OB 07	14	23.87	20.24	15.24
DF OB 10	20	31.49	27.86	22.86
DF OB 17	34	49.27	45.64	40.64
DF OB 18	36	51.81	48.18	43.18

contact surface finish: tin-plated

F

G

H

I

K

L

M

N

G 55

 Male headers 2.54 solder
 Screw fastening
 Male con./fem. con. 6.00 solder
 Technical data

 → G 8
 → I 28
 → G 2
 → G 75 - 80

 Special male & female headers
 Female headers 2.54 solder

 → G 19
 → G 27

□ 0.5 mm, straight

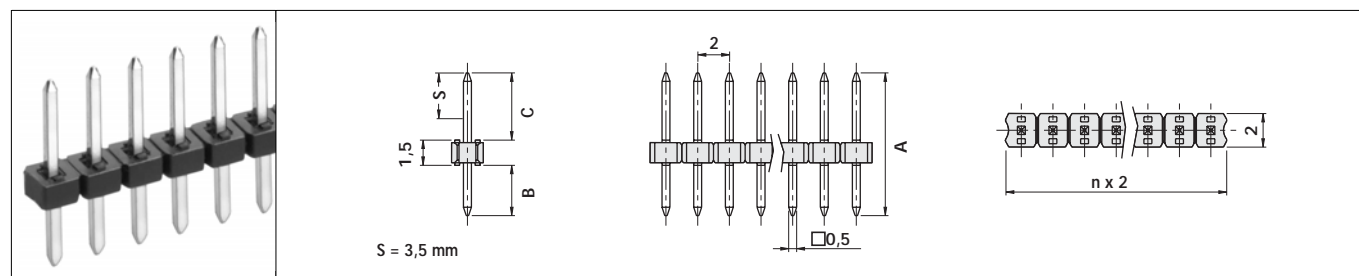

art. no.	dim. [mm]		
	A	B	C
SLY 1 081 ...	8.10	3.00	3.60
SLY 1 085 ...	8.50	3.00	4.00
SLY 1 098 ...	9.80	3.00	5.30
SLY 1 104 ...	10.40	3.00	5.90
SLY 1 139 ... G	13.90	3.00	9.40
SLY 1 139 ... Z	13.90	3.00	9.40

please indicate: ... no. of contacts one row 1-50 ... surface S = selective gold-plated G = gold-plated Z = tin-plated

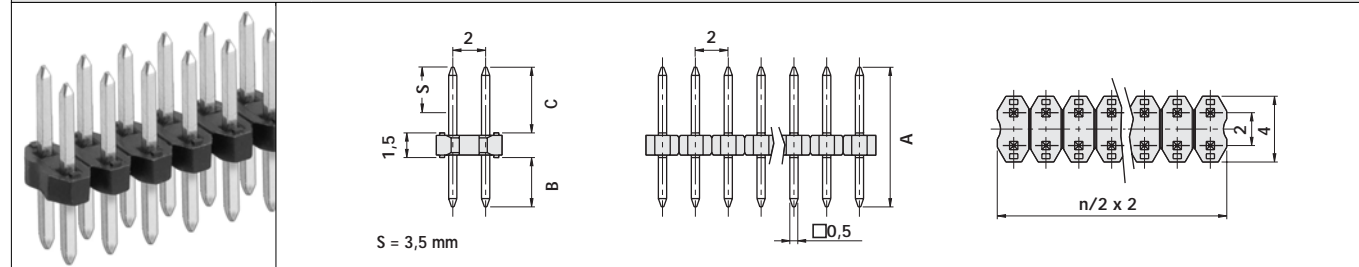

art. no.	dim. [mm]		
	A	B	C
SLY 2 081 ...	8.10	3.00	3.60
SLY 2 085 ...	8.50	3.00	4.00
SLY 2 098 ...	9.80	3.00	5.30
SLY 2 104 ...	10.40	3.00	5.90
SLY 2 139 ... G	13.90	3.00	9.40
SLY 2 139 ... Z	13.90	3.00	9.40

please indicate: ... no. of contacts two rows 4-100 ... surface S = selective gold-plated G = gold-plated Z = tin-plated

Male headers soldering technique

□ 0.5 mm, angled

art. no.	dim. [mm]		
	A	B	C
SLY 3 035 ...	1.50	2.80	3.50
SLY 3 041 ...	1.50	2.80	4.10
SLY 3 082 ...	1.50	2.80	8.20
please indicate:	... no. of contacts one row 1 - 50	... surface S = selective gold-plated G = gold-plated Z = tin-plated	
art. no.	dim. [mm]		
	A	B	C
SLY 4 035...	1.50	2.80	3.50
SLY 4 041...	1.50	2.80	4.10
SLY 4 082...	1.50	2.80	8.20
please indicate:	... no. of contacts two rows 4 - 100	... surface S = selective gold-plated G = gold-plated Z = tin-plated	

Therefore any required number of contacts is available.

□ 0.5 mm

suitable for female headers BLY

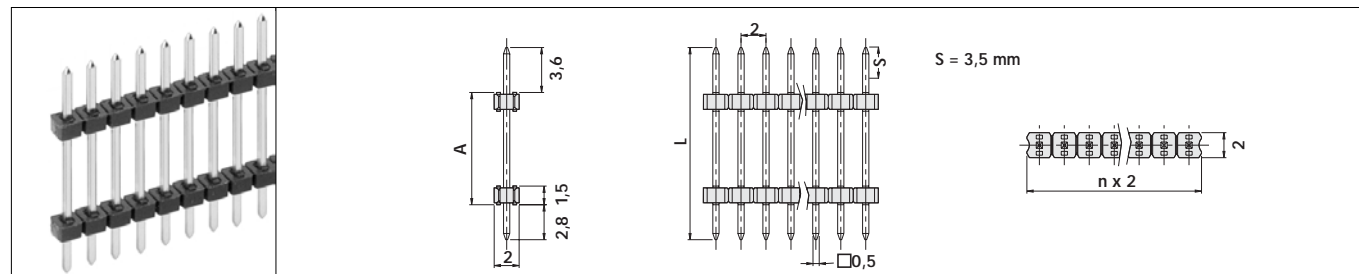

art. no.	dim. [mm]		art. no.	dim. [mm]	
	A	L		A	L
SLY 5 040 ...	4.00	10.40	SLY 5 101 ...	10.10	16.50
SLY 5 075 ...	7.50	13.90	SLY 5 122 ...	12.20	18.60
SLY 5 081 ...	8.10	14.50			

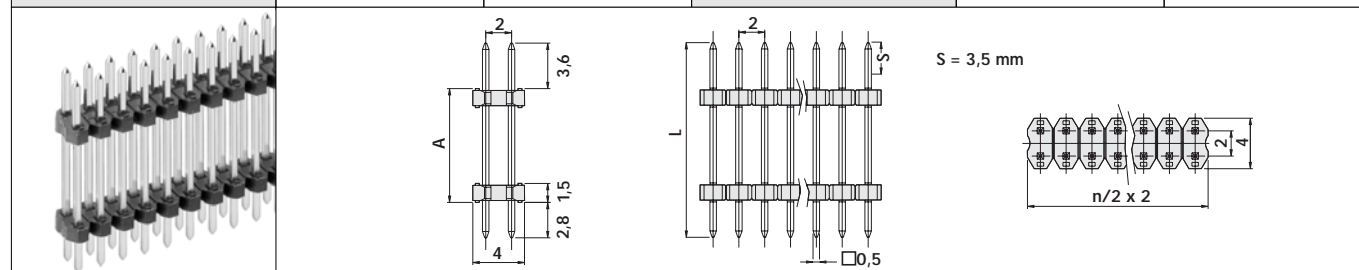

art. no.	dim. [mm]		art. no.	dim. [mm]	
	A	L		A	L
SLY 6 040 ...	4.00	10.40	SLY 6 101 ...	10.10	16.50
SLY 6 075 ...	7.50	13.90	SLY 6 122 ...	12.20	18.60
SLY 6 081 ...	8.10	14.50			

please indicate:

... no. of contacts	... surface
one row 1-50	S = selective gold-plated
two rows 2-100	G = gold-plated
	Z = tin-plated

Are used for interconnections of stacked PCBs.

The position of the insulator can be changed within the total length of the pin.

Therefore any required number of contacts is available.

A



B

Empty page

C

D

E

F

G

H

I

K

L

M

N

High-precision female headers soldering technique

for □ 0.5 mm and up to 0.56 mm Ø

art. no.		
BLY 1 ...		
art. no.		
BLY 2 ...		
art. no.		
BLY 3 ...		
art. no.		
BLY 4 ...		
please indicate:	... no. of contacts one row 1-50 two rows 2-100	

contact shell surface: tin-plated

contact spring: gold-plated

No capillary action when soldering due to protected contact insert.

V-notches permit breaking! Therefore any required number of contacts is available.

A

B

C

D

E

F

G

H

I

K

L

M

N

Male headers in SMD mounting

□ 0.5 mm

art. no.	dim. [mm]		
	A	B	S
SLY 7 SMD 036 ...	5.60	6.30	3.00
SLY 7 SMD 045 ...	6.50	4.60	3.50
SLY 7 SMD 062 ...	8.20	4.60	3.50
please indicate:	... no. of contacts one row 4-20	... surface S = sel. gold-plated G = gold-plated Z = tin-plated	... packing (option) SM = bar magazine B SM = pick and place pad and bar magazine
art. no.	dim. [mm]		
	A	B	S
SLY 8 SMD 036 ...	5.60	8.50	3.00
SLY 8 SMD 045 ...	6.50	6.50	3.50
SLY 8 SMD 062 ...	8.20	6.50	3.50
please indicate:	... no. of contacts two rows 4-40	... surface S = sel. gold-plated G = gold-plated Z = tin-plated	... packing (option) SM = bar magazine B SM = pick and place pad and bar magazine B TR = pick and place pad and tape and reel (650 pcs/reel)

... packing (option) - additions:

SLY 8 SMD ... SM; ... B SM: 6-40 contacts
 SLY 8 SMD 036/045 B TR: 6-30 contacts

For further informations please see "for automatic assembly" following this series!

□ 0.5 mm

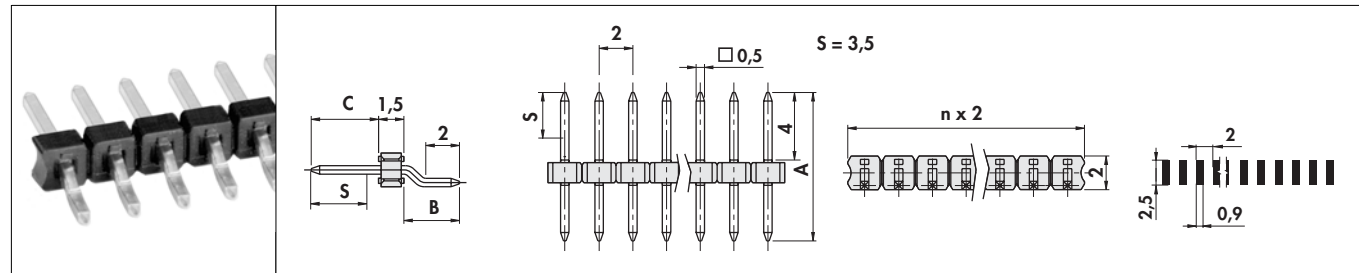

art. no.	dim. [mm]			
	A	B	C	S
SLY 9 SMD 040 ...	8.80	3.30	4.00	3.50
SLY 9 SMD 055 ...	10.30	3.30	5.50	3.50

please indicate: ... no. of contacts one row 2-20 ... surface S = sel. gold-plated G = gold-plated Z = tin-plated ... packing (option) B SM = pick and place pad and bar magazine

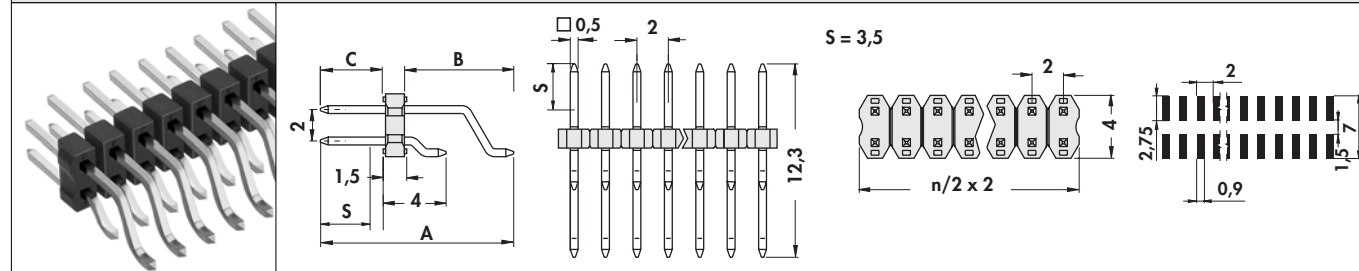

art. no.	dim. [mm]			
	A	B	C	S
SLY 10 SMD 040 ...	12.30	6.80	4.00	3.50

please indicate: ... no. of contacts two rows 4-40 ... surface S = sel. gold-plated G = gold-plated Z = tin-plated ... packing (option) B SM = pick and place pad and bar magazine B TR = pick and place pad and tape and reel (700 pcs/reel)

... packing (option) - additions:

SLY 10 SMD 040: ... B TR, 4-16 contacts

For further informations please see "for automatic assembly" following this series!

A



Male headers in SMD mounting

B

Empty page

C

D

E

F

G

H

I

K

L

M

N

High-precision female headers in SMD mounting

for \square 0.5 mm and up to 0.56 mm \varnothing

<p>art. no.</p> <p>BLY 5 SMD ...</p>	
<p>please indicate: ... no. of contacts one row 4-20 ... packing (option) B SM = pick and place pad and bar magazine</p>	
<p>art. no.</p> <p>BLY 6 SMD ...</p>	
<p>please indicate: ... no. of contacts one row 2-20 ... packing (option) TR = tape and reel (2.400 pcs/reel)</p>	
<p>art. no.</p> <p>BLY 8 SMD ...</p>	
<p>please indicate: ... no. of contacts two rows 4-40 ... packing (option) B SM = pick and place pad and bar magazine B TR = pick and place pad and tape and reel (650 pcs/reel)</p>	

contact shell surface: tin-plated
 contact spring: gold-plated

No capillary action when soldering due to protected contact insert.
 V-notches permit breaking! Therefore any required number of contacts is available.

... packing (option) - additions:

BLY 6 SMD ... TR: 2-10 contacts
BLY 8 SMD ... B TR: 6-30 contacts

For further informations please see "for automatic assembly" following this series!

A



High-precision female headers in SMD mounting

B

Empty page

C

D

E

F

G

H

I

K

L

M

N

Male headers soldering technique

□ 0,4 mm

suitable for female header BLM, one row 1-36 contacts

art. no.	dim. [mm]		
	A	B	C
SLV W 1 055 ...	9.70	2.50	5.50
SLV W 1 080 ...	12.20	2.50	8.00
SLV W 1 105 ...	14.70	2.50	10.50
SLV W 1 130 ...	17.20	2.50	13.00
please indicate:	... no. of contacts one row 1-36	... surface G=gold-plated Z=tin-plated	

suitable for female header BLM, two rows 4-72 contacts, grid spacing 1,27 x 2,54 mm

art. no.	dim. [mm]		
	A	B	C
SLV W 2 055 ...	9.70	2.50	5.50
SLV W 2 080 ...	12.20	2.50	8.00
SLV W 2 105 ...	14.70	2.50	10.50
SLV W 2 130 ...	17.20	2.50	13.00
please indicate:	... no. of contacts two rows 4-72	... surface G=gold-plated Z=tin-plated	

Male headers soldering technique

0.4 mm, 90° angled

one row 1-36 contacts

art. no.	dim. [mm]		
	A	B	C
SLV W 1 KA 030 ...	3.90	2.50	3.00
SLV W 1 KA 055 ...	3.90	2.50	5.50
SLV W 1 KA 080 ...	3.90	2.50	8.00
SLV W 1 KA 105 ...	3.90	2.50	10.50

please indicate: ... no. of contacts one row 1-36 ... surface G=gold-plated Z=tin-plated

suitable for female header BLM, two rows 6-72 contacts, grid spacing 1,27 x 2,54 mm

art. no.	no. of contacts	VPE	dim. [mm]			art. no.	no. of contacts	VPE	dim. [mm]		
			A	B	C				A	B	C
SLVW2 KA 030 10...	10	78	3.70	2.50	3.00	SLVW2 KA 054 10...	10	78	3.70	2.50	5.40
SLVW2 KA 030 14...	14	55	3.70	2.50	3.00	SLVW2 KA 054 14...	14	55	3.70	2.50	5.40
SLVW2 KA 030 16...	16	50	3.70	2.50	3.00	SLVW2 KA 054 16...	16	50	3.70	2.50	5.40
SLVW2 KA 030 20...	20	40	3.70	2.50	3.00	SLVW2 KA 054 20...	20	40	3.70	2.50	5.40
SLVW2 KA 030 26...	26	31	3.70	2.50	3.00	SLVW2 KA 054 26...	26	31	3.70	2.50	5.40
SLVW2 KA 030 30...	30	27	3.70	2.50	3.00	SLVW2 KA 054 30...	30	27	3.70	2.50	5.40
SLVW2 KA 030 34...	34	24	3.70	2.50	3.00	SLVW2 KA 054 34...	34	24	3.70	2.50	5.40
SLVW2 KA 030 40...	40	20	3.70	2.50	3.00	SLVW2 KA 054 40...	40	20	3.70	2.50	5.40
SLVW2 KA 030 50...	50	16	3.70	2.50	3.00	SLVW2 KA 054 50...	50	16	3.70	2.50	5.40
SLVW2 KA 030 72...	72	11	3.70	2.50	3.00	SLVW2 KA 054 72...	72	11	3.70	2.50	5.40

please indicate: ... surface G=gold-plated Z=tin-plated

SLV W 2 KA ...: packing bar magazine

VPE = packing unit (pieces/tube);

preferred number of contacts, different ones between 6 and 72 can be made upon request

Female headers 1.27 SMD → G 74
 High-prec. fem. headers 1.27 solder → G 72
 High-prec. female headers SMD → G 76
 Single contacts metal strip → G 26

High-prec. male head.in SMD mount. → G 35
 Jumpers → G 77 - 78
 Jump. links 2.00 & 2.54 solder → G 20

G 68

A

B

C

D

E

F

G

H

I

K

L

M

N

A
B
C
D
E
F
G
H
I
K
L
M
N

Male headers soldering technique

Straight, narrow insulator □ 0.4 mm

suitable for female header BLM, one row 1-20 contacts

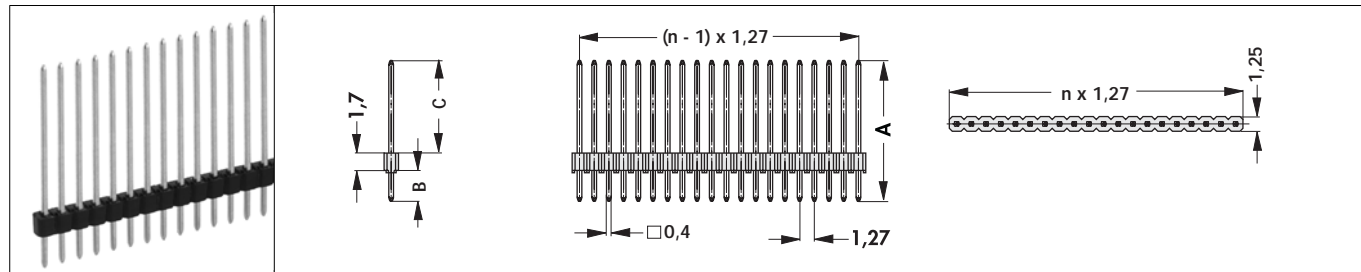

art. no.	dim. [mm]		
	A	B	C
SLV N 1 055 ...	9.70	2.50	5.50
SLV N 1 080 ...	12.20	2.50	8.00
SLV N 1 105 ...	14.70	2.50	10.50
SLV N 1 130 ...	17.20	2.50	13.00
SLV N 11 055 ...	12.20	5.00	5.50
SLV N 11 080 ...	14.70	5.00	8.00
SLV N 11 105 ...	17.20	5.00	10.50

please indicate: ... no. of contacts one row 1 - 20 ... surface
G = gold-plated
Z = tin-plated

suitable for male header SLM and SLV, one row 1-36 contacts

art. no.	dim. [mm] A
BLM KG 1 ...	3.00
BLM LG 1 ...	5.10
art. no.	BLM LA 1 ...
please indicate:	... no. of contacts one row 1-36
	... surface G =gold-plated Z =tin-plated

suitable for male header SLV, two rows 4-72 contacts - grid spacing 1.27 x 2.54 mm

art. no.	dim. [mm] A
BLM KG 2 ...	3.00
BLM LG 2 ...	5.10
please indicate:	... no. of contacts two rows 4-72
	... surface G =gold-plated Z =tin-plated

High-precision male headers soldering technique

Ø 0.43 mm

turned precision contacts, less space required on PCB

art. no.	no. of contacts		
SLR 1 025 ...	25		
SLR 1 050 ...	50		
art. no.	no. of contacts		
SLR 2 050 ...	50		
SLR 2 100 ...	100		
art. no.	no. of contacts		
SLR 3 025 ...	25		
SLR 3 050 ...	50		
art. no.	no. of contacts		
SLR 4 050 ...	50		
SLR 4 100 ...	100		
please indicate:	... surface G =gold-plated Z =tin-plated		

Other number of contacts on request!

High-precision female headers soldering technique

for Ø 0.35–0.45 mm

art. no.	no. of contacts		
BLR 1 025 Z	25		
BLR 1 050 Z	50		
art. no.	no. of contacts		
BLR 2 050 Z	50		
BLR 2 100 Z	100		
art. no.	no. of contacts		
BLR 3 025 Z	25		
BLR 3 050 Z	50		
art. no.	no. of contacts		
BLR 4 050 Z	50		
BLR 4 100 Z	100		

contact shell surface: tin-plated

contact spring: gold-plated

No capillary action when soldering due to protected contact insert.

Other number of contacts on request!

Special male & female headers → G 19
 Female headers 1.27 solder → G 70
 High-prec. male headers 1.27 SMD → G 75
 Technical data → G 75 - 80

Special male & female headers → G 19
 High-prec.female headers SMD → G 76
 High-prec. male head. 1.27 solder → G 71

G 72

A

B

C

D

E

F

G

H

I

K

L

M

N

Male headers in SMD mounting

□ 0.4 mm

suitable for female header BLM, one row 4-20 contacts

art. no.	dim. [mm]
	A B C
SLV W 1 SMD 048...	8.20 4.00 4.80
SLV W 1 SMD 073...	10.70 4.00 7.30
please indicate:	... no. of contacts one row 4-20
	... surface G =gold-plated Z =tin-plated

suitable for female header BLM, two rows 4-40 contacts, grid spacing 1,27 x 2,54 mm

art. no.	dim. [mm]
	A B C
SLV W 2 SMD 048...	8.20 6.60 4.80
SLV W 2 SMD 073...	10.70 6.60 7.30
please indicate:	... no. of contacts two rows 4-40
	... surface G =gold-plated Z =tin-plated

Wide insulator with 0.3 mm and 0.4 mm

suitable for male header SLM and SLV, one row 4-20 contacts

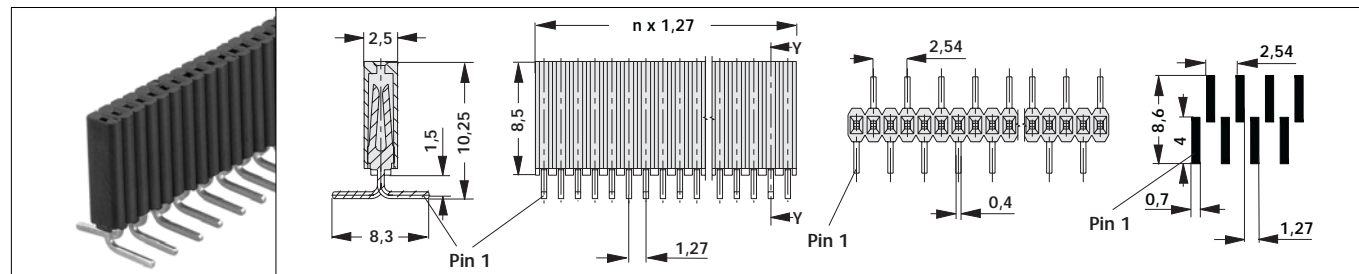

art. no.

BLM 1 SMD ...

please indicate: ... no. of contacts one row 4-20 ... surface G=gold-plated Z=tin-plated

Grid spacing 1.27 x 2.54 mm

suitable for male header SLV, two rows 4-40 contacts

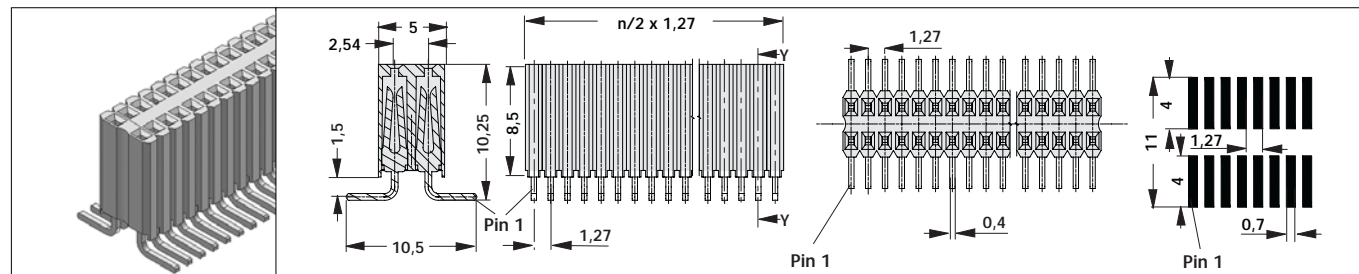

art. no.

BLM 2 SMD ...

please indicate: ... no. of contacts two rows 4-40 ... surface G=gold-plated Z=tin-plated

High-precision male headers in SMD mounting

Turned precision contacts

less space required on PCB

art. no.	no. of contacts		
SLR 5 SMD ...	50		
please indicate:	... surface G = gold-plated Z = tin-plated		
art. no.	no. of contacts		
SLR 6 SMD ...	100		
please indicate:	... surface G = gold-plated Z = tin-plated		
art. no.	no. of contacts		
SLR 7 SMD ...	50		
please indicate:	... surface G = gold-plated Z = tin-plated		

Other number of contacts on request!

High-precision female headers in SMD mounting

Turned precision contacts for Ø 0.35-0.45 mm

less space required on PCB

art. no. BLR 5 SMD	no. of contacts 50	
art. no. BLR 6 SMD	no. of contacts 100	
art. no. BLR 7 SMD	no. of contacts 50	

contact shell: tin-plated

contact insert: gold-plated

Closed precision rotary part with 3-finger contact prevents rising of flux agents.

Other number of contacts on request!

for 0.6-0.64 mm wire wrap pins and Ø 0.6-0.7 mm

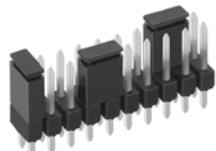
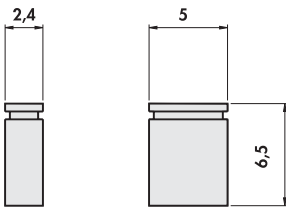
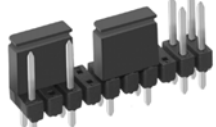
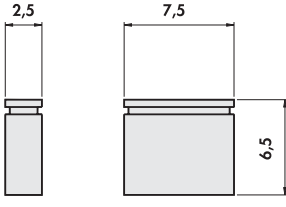
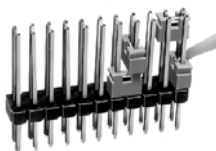
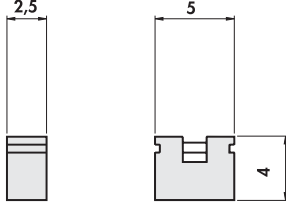
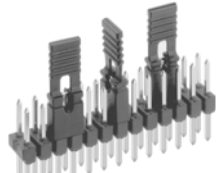
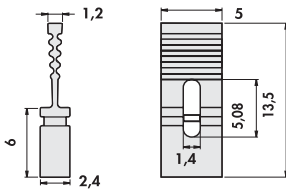
art. no.	no. of contacts	surface	version	grid			
CAB 4 G ...	2	0.1 µm gold	closed	2.54			
CAB 4 Z ...	2	5.0 µm tin	closed	2.54			
CAB 5 05 G ...	2	0.5 µm gold	closed, hole for probe trip	5.08			
CAB 5 10 G ...	2	1.0 µm gold	closed, hole for probe trip	5.08			
CAB 5 Z ...	2	5.0 µm tin	closed, hole for probe trip	5.08			
CAB 6 05 G ...	2	0.5 µm gold	open, suitable for miniature test probes	2.54			
CAB 6 10 G ...	2	1.0 µm gold	open, suitable for miniature test probes	2.54			
CAB 6 Z ...	2	5.0 µm tin	open, suitable for miniature test probes	2.54			
CAB 9 G ...	2	0.1 µm gold	tag, open	2.54			
please indicate:							
<p>... colour B = blue G = grey R = red S = black</p>							

Colour "grey" except for CAB 9.

The flexible contacts are shorting two pins. The jumpers can be mounted behind and next to each other.

for square 0.5 mm and Ø 0.4-0.5 mm

art. no.	no. of contacts	surface	version	grid		
CAB 10 G S	2	0.1 µm gold	open, suitable for miniature test probes	2.00		
CAB 11 G S	2	0.1 µm gold	open, suitable for miniature test probes	2.00		
CAB 14 G S	2	<0,1 µm gold	tag, open, suitable for miniature test probes	2.00		

colour:

black

for square 0.3-0.4 mm and Ø 0.4-0.5 mm

art. no.	no. of contacts	surface	version	grid		
CAB 15 G S	2	<0,1 µm gold	closed, tag	1.27		

colour:

black

A

B

C

D

E

F

G

H

I

K

L

M

N

Technical data
 High-prec. male head. 1.27 solder → G 73 - 78
 High-prec. male headers 1.27 SMD → G 71
 Male headers 2.54 press-fit → G 75
 → G 51

Single contacts metal strip → G 26
 Male headers 2.00 solder → G 56 - 58
 Male headers 2.00 SMD → G 61 - 62

G 78

Design DIL

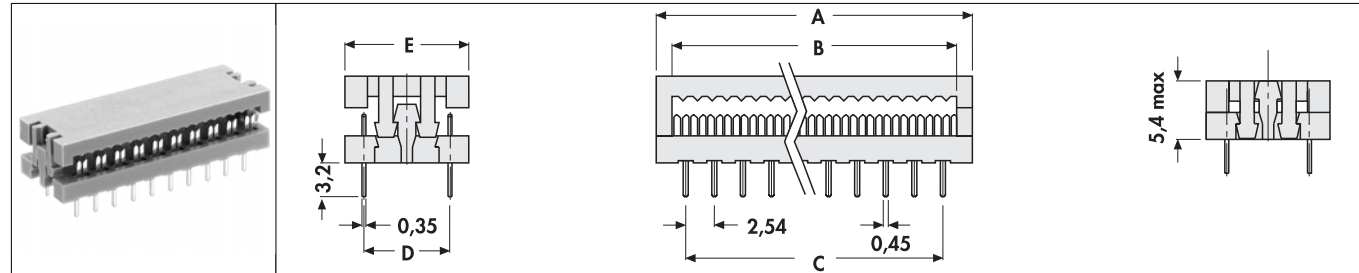

art. no.	no. of contacts	dim. [mm]				
		A	B	C	D	E (max.)
KK 04 Z	4	8.00	5.10	2.54	7.62	11.00
KK 06 Z	6	10.30	7.60	5.08	7.62	11.00
KK 08 Z	8	13.00	10.20	7.62	7.62	11.00
KK 10 Z	10	15.40	12.70	10.16	7.62	11.00
KK 12 Z	12	18.00	15.30	5.08	7.62	11.00
KK 14 Z	14	20.50	17.80	15.24	7.62	11.00
KK 16 Z	16	23.00	20.30	17.78	7.62	11.00
KK 18 Z	18	25.60	22.90	20.32	7.62	11.00
KK 20 Z	20	28.10	25.40	22.86	7.62	11.00
KK 24 Z	24	33.00	30.50	27.94	15.24	18.70
KK 28 Z	28	38.10	35.60	33.02	15.24	18.70
KK 40 Z	40	53.30	50.80	48.26	15.24	18.70

Use with ribbon cable:

round conductor flat strip:
 AWG 28 = solid or stranded
 AWG 30 = solid

conductor diameter:
 AWG 28 ... 30 = 0.09 ... 0.05 mm²
 insulation-Ø:
 max. 1.1 mm

A

B

C

D

E

F

G

H

I

K

L

M

N

Female connector

One row

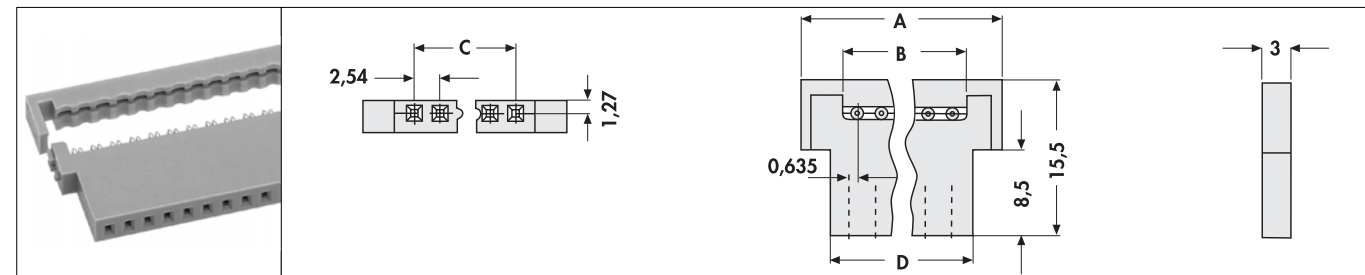

art. no.	no. of contacts	dim. [mm]			
		A	B	C	D
FV 03 ...	3	15.24	7.62	5.08	8.89
FV 04 ...	4	17.78	10.16	7.62	11.43
FV 05 ...	5	20.32	12.70	10.16	7.62
FV 06 ...	6	22.86	15.24	5.08	16.51
FV 07 ...	7	25.40	17.78	15.24	19.05
FV 08 ...	8	27.94	20.32	17.78	21.59
FV 10 ...	10	33.02	25.40	22.86	26.67
FV 12 ...	12	38.10	30.48	27.94	31.75
FV 13 ...	13	40.64	33.02	30.48	34.29
FV 14 ...	14	43.18	35.66	33.02	36.83
FV 16 ...	16	48.26	40.64	38.10	41.91
FV 17 ...	17	50.80	43.18	40.64	44.45
FV 18 ...	18	53.34	45.72	43.18	46.99
FV 20 ...	20	58.42	50.80	48.26	52.07
FV 24 ...	24	68.58	60.96	58.42	62.23
FV 25 ...	25	71.12	63.50	60.96	64.77
FV 36 ...	36	99.06	91.44	88.90	92.71

please indicate: ... surface
G = gold-plated
Z = tin-plated

recommended plugs
 0.635 mm
 length 5 ... 8 mm

Use with ribbon cable:
 round conductor flat strip:
 AWG 28 = solid or stranded
 AWG 30 = solid

conductor diameter:
 AWG 28 ... 30 = 0.09 ... 0.05 mm²
 insulation-Ø:
 max. 1.1 mm

Female connector

Two rows, with guiding nose

suitable for shrouded male header ASL ...

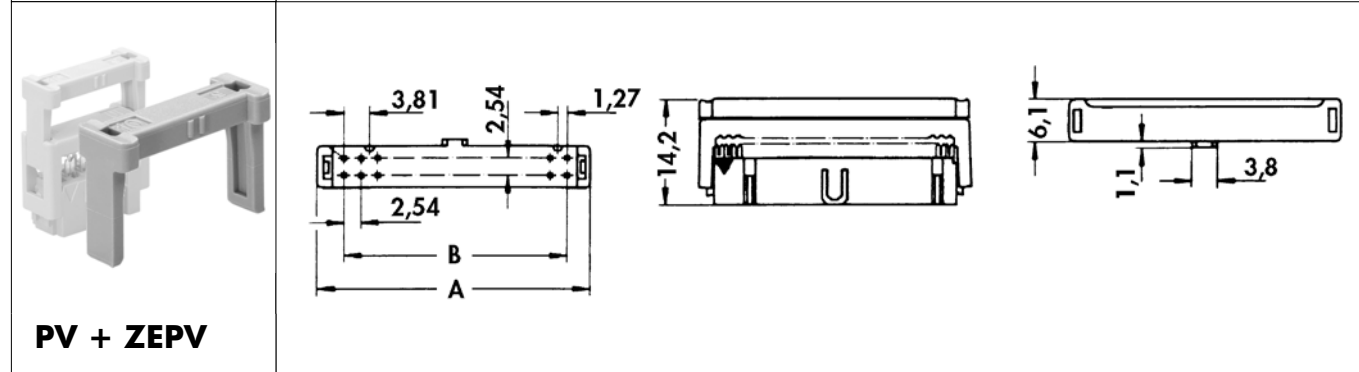
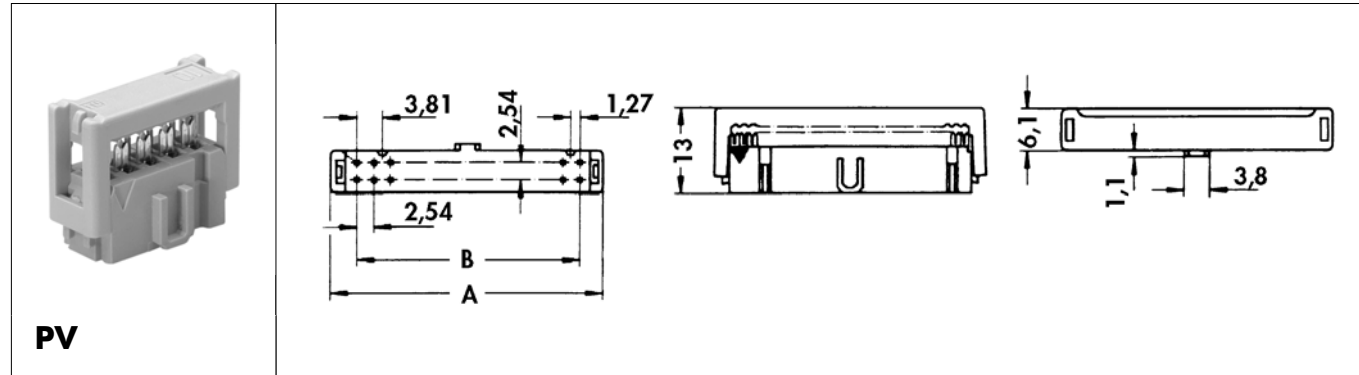

art. no.	no. of contacts	dim. [mm]		suitable strain relief
		A	B	
PV 06 G	6	12.20	5.08	ZEPV 06
PV 10 G	10	17.30	10.16	ZEPV 10
PV 14 G	14	22.40	15.24	ZEPV 14
PV 16 G	16	24.90	17.78	ZEPV 16
PV 20 G	20	30.00	22.86	ZEPV 20
PV 26 G	26	37.60	30.48	ZEPV 26
PV 34 G	34	47.80	40.64	ZEPV 34
PV 40 G	40	55.40	48.26	ZEPV 40
PV 50 G	50	68.10	60.96	ZEPV 50

contact surface finish: gold-plated

Use with ribbon cable:

round conductor flat strip:
 AWG 28 = solid or stranded
 AWG 30 = solid

conductor diameter:
 AWG 28 ... 30 = 0.09 ... 0.05 mm²
 insulation-Ø:
 max 1.1 mm

A

B

C

D

E

F

G

H

I

K

L

M

N

Male headers 2.54 solder
 Application tools
 Single contacts metal strip
 Technical data

→ G 8
 → H 11
 → G 26
 → H 12

Boltable female header
 Shroud. male header SMD
 Shrouded male header

→ H 5
 → H 7
 → H 6

H 4

Female connector

Two rows, with guiding nose

boltable female header, suitable for shrouded male header ASL ...

art. no.	no. of contacts	dim. [mm]		art. no.	no. of contacts	dim. [mm]	
		A	B			A	B
VFL 06 ...	6	23.58	9.56	VFL 20 ...	20	41.36	27.34
VFL 08 ...	8	26.12	12.10	VFL 26 ...	26	48.98	34.96
VFL 10 ...	10	28.66	14.64	VFL 34 ...	34	59.14	45.12
VFL 12 ...	12	31.20	17.18	VFL 40 ...	40	66.76	52.74
VFL 14 ...	14	33.74	19.72	VFL 50 ...	50	79.46	65.44
VFL 16 ...	16	36.28	22.26				
please indicate:		... surface G =gold-plated Z =tin-plated					

suitable for shrouded male header ASL ...

art. no.	no. of contacts	dim. [mm]		art. no.	no. of contacts	dim. [mm]	
		A	B			A	B
FLMP 06 ...	6	10.97	9.56	FLMP 20 ...	20	28.75	27.34
FLMP 08 ...	8	13.51	12.10	FLMP 26 ...	26	36.37	34.96
FLMP 10 ...	10	16.05	14.64	FLMP 34 ...	34	46.53	45.12
FLMP 12 ...	12	18.59	17.18	FLMP 40 ...	40	54.15	52.74
FLMP 14 ...	14	21.13	19.72	FLMP 50 ...	50	66.85	65.44
FLMP 16 ...	16	23.67	22.26				
please indicate:		... surface G =gold-plated Z =tin-plated					

Use with ribbon cable:

round conductor flat strip:
AWG 28 = solid or stranded
AWG 30 = solid

conductor diameter:
AWG 28 ... 30 = 0.09 ... 0.05 mm²
insulation-Ø: max 1.1 mm

Male header

Straight, two rows, shrouded

suitable for boltable female header VFL, FLMP, PV

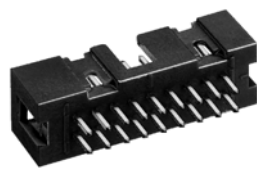
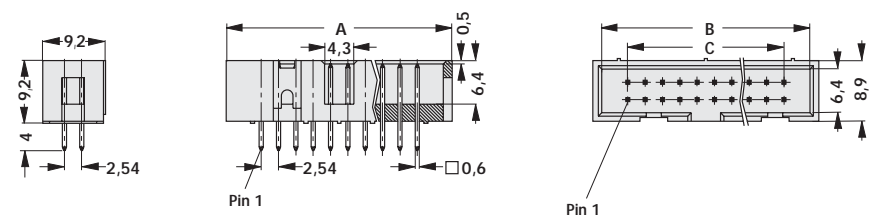



art. no.	no. of contacts	dim. [mm]			art. no.	no. of contacts	dim. [mm]		
		A	B	C			A	B	C
ASLG 06 ...	6	15.30	12.70	5.08	ASLG 20 ...	20	33.10	30.50	22.86
ASLG 08 ...	8	17.80	15.20	7.62	ASLG 26 ...	26	40.70	38.10	30.48
ASLG 10 ...	10	20.40	17.80	10.16	ASLG 34 ...	34	50.90	48.30	40.64
ASLG 12 ...	12	22.90	20.30	12.70	ASLG 40 ...	40	58.50	55.90	48.26
ASLG 14 ...	14	25.40	22.90	15.24	ASLG 50 ...	50	71.20	68.60	60.96
ASLG 16 ...	16	28.00	25.40	17.78					

please indicate: ... surface
G = gold-plated
Z = tin-plated

Angled, two rows, shrouded

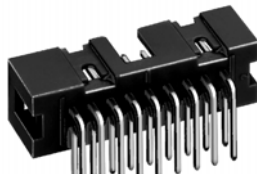
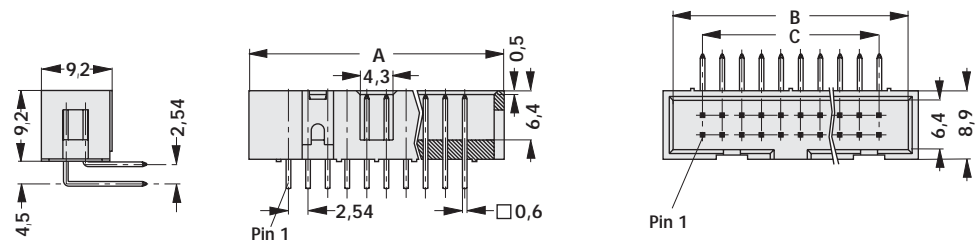
suitable for boltable female header VFL, FLMP, PV

art. no.	no. of contacts	dim. [mm]			art. no.	no. of contacts	dim. [mm]		
		A	B	C			A	B	C
ASLA 06 ...	6	15.30	12.70	5.08	ASLA 20 ...	20	33.10	30.50	22.86
ASLA 08 ...	8	17.80	15.20	7.62	ASLA 26 ...	26	40.70	38.10	30.48
ASLA 10 ...	10	20.40	17.80	10.16	ASLA 34 ...	34	50.90	48.30	40.64
ASLA 12 ...	12	22.90	20.30	12.70	ASLA 40 ...	40	58.50	55.90	48.26
ASLA 14 ...	14	25.40	22.90	15.24	ASLA 50 ...	50	71.20	68.60	60.96
ASLA 16 ...	16	28.00	25.40	17.78					

please indicate: ... surface
G = gold-plated
Z = tin-plated

Gold-plated resp. tin-plated contacts are available with either straight or squared terminations. In addition they can be combined with many other stripline connectors in 2.54 mm pitch.

Male header

SMD, two rows, shrouded

suitable for boltable female header VFL, FLMP, PV

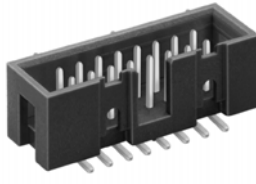
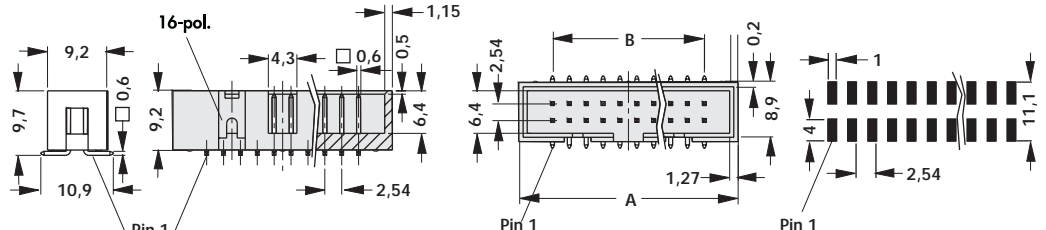
art. no.	no. of contacts	VPE	dim. [mm]		art. no.	no. of contacts	VPE	dim. [mm]	
			A	B				A	B
ASL 06 SMD ...	6	32	15.30	5.08	ASL 20 SMD ...	20	15	33.10	22.86
ASL 08 SMD ...	8	27	17.80	7.62	ASL 26 SMD ...	26	12	40.70	30.48
ASL 10 SMD ...	10	24	20.40	10.16	ASL 34 SMD ...	34	9	50.90	40.64
ASL 12 SMD ...	12	21	22.90	12.70	ASL 40 SMD ...	40	8	58.50	48.26
ASL 14 SMD ...	14	19	25.40	15.24	ASL 50 SMD ...	50	7	71.20	60.96
ASL 16 SMD ...	16	17	28.00	17.78					

please indicate:

... surface	... packing (option)
G = gold-plated	SM = bar magazine
Z = tin-plated	B SM = pick and place pad and bar magazine

VPE = packing unit (pieces/tube); Gold-plated resp. tin-plated contacts are available with either straight or squared terminations.

In addition they can be combined with many other strip-line connectors in 2.54 mm pitch.

For automatic assembly: Pick and place pad "B" and tube magazin "SM"

– position in the middle

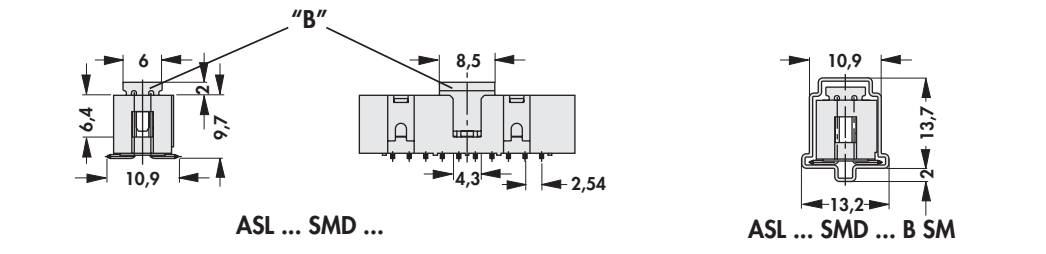
art. no.
... B SM

Printed circuit connector

One row

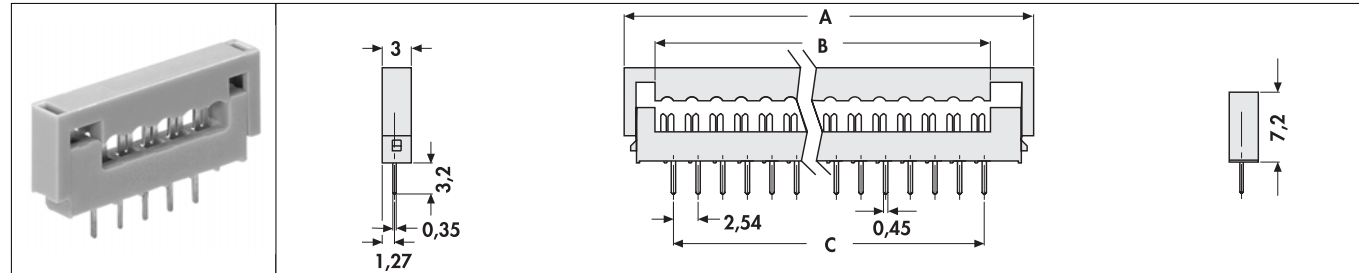

art. no.	no. of contacts	dim. [mm]			art. no.	no. of contacts	dim. [mm]		
		A	B	C			A	B	C
SBAU 1 04 Z	4	17.78	10.16	7.62	SBAU 1 14 Z	14	43.18	35.56	33.02
SBAU 1 06 Z	6	22.86	15.24	12.70	SBAU 1 16 Z	16	48.26	40.64	38.10
SBAU 1 08 Z	8	27.94	20.32	17.78	SBAU 1 17 Z	17	50.80	43.18	40.64
SBAU 1 10 Z	10	33.02	25.40	22.86	SBAU 1 18 Z	18	53.34	45.72	43.18
SBAU 1 12 Z	12	38.10	30.48	27.94	SBAU 1 20 Z	20	58.42	50.80	48.26

contact surface finish: tin-plated

Two rows

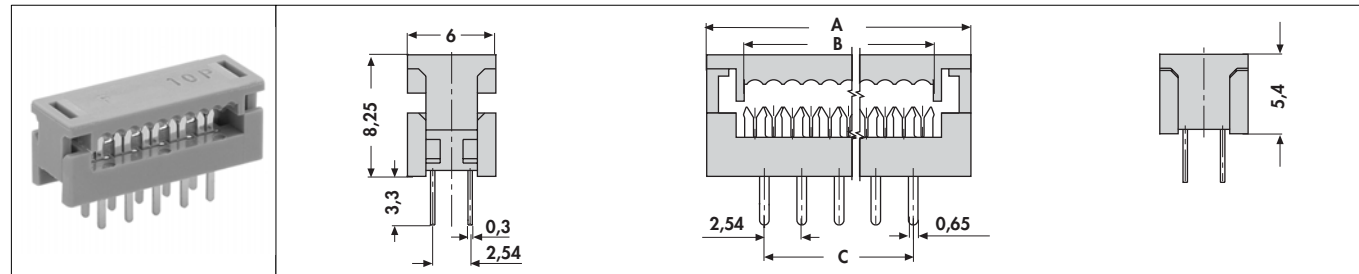

art. no.	no. of contacts	dim. [mm]			art. no.	no. of contacts	dim. [mm]		
		A	B	C			A	B	C
SBAU 06 S	6	12.90	7.80	5.08	SBAU 20 S	20	30.70	25.60	22.86
SBAU 10 S	10	18.00	12.90	10.16	SBAU 26 S	26	38.30	33.20	30.48
SBAU 14 S	14	23.00	18.00	15.24	SBAU 34 S	34	48.50	43.40	40.64
SBAU 16 S	16	25.60	20.50	17.78					

contact surface finish: selective gold-plated: solder area gold-plated, IDC area nickel-plated

Use with ribbon cable:

round conductor flat strip:

AWG 28 = solid or stranded, AWG 30 = solid

conductor diameter:

AWG 28 ... 30 = 0.09 ... 0.05 mm²

insulation-Ø:

max. 1.1 mm

Printed circuit connector

Four rows

art. no.	no. of contacts	dim. [mm]			art. no.	no. of contacts	dim. [mm]		
SBAU 4 10 S	10	17.78	12.70	11.43	SBAU 4 26 S	26	38.10	33.02	31.75
SBAU 4 16 S	16	25.40	20.32	19.05	SBAU 4 50 S	50	68.58	63.50	62.23
SBAU 4 20 S	20	30.48	25.40	24.13					

contact surface finish: **S** = selective-gold-plated: soldering area gold plated, IDC nickel-plated

Use with ribbon cable:

round conductor flat strip:
AWG 28 = solid or stranded, AWG 30 = solid

conductor diameter:
AWG 28 ... 30 = 0.09 ... 0.05 mm²
insulation-Ø:
max. 1.1 mm

Print-layout for SBAU 4 ...

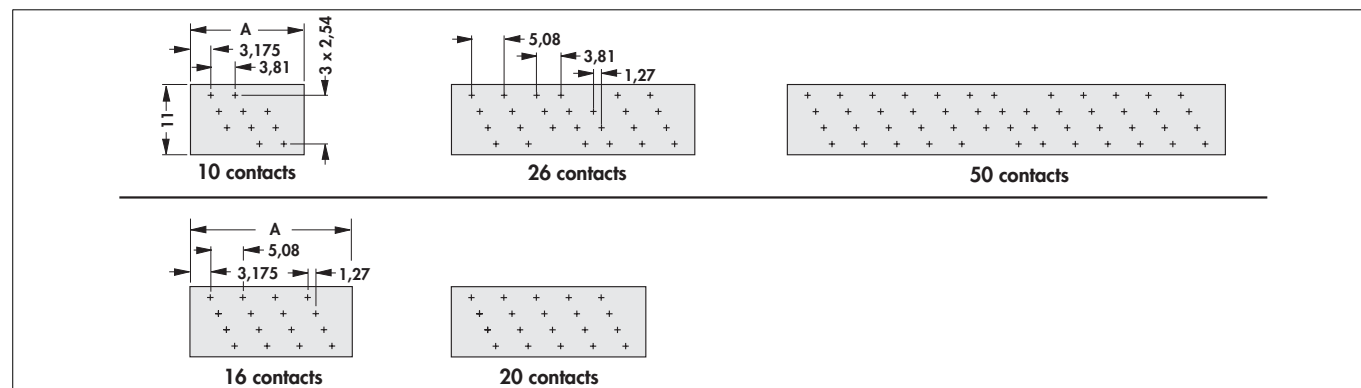

Female connector

Two rows

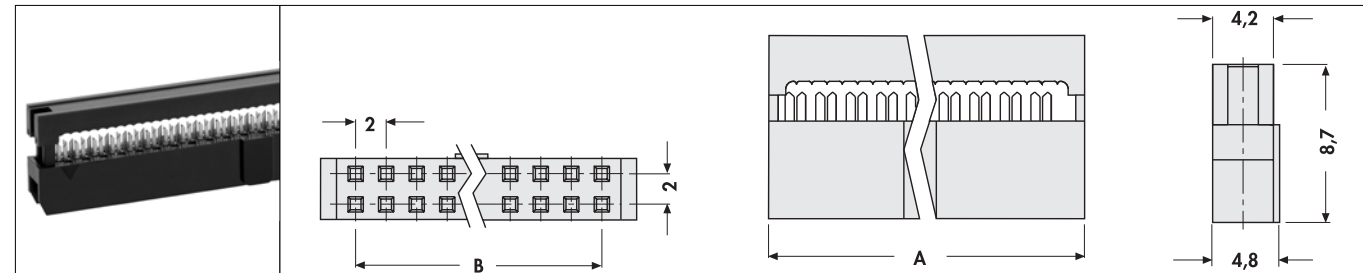

art. no.	no. of contacts	dim. [mm]	
		A	B
PVY 20 S	20	25.10	18.00
PVY 40 S	40	45.30	38.00
PVY 44 S	44	49.30	42.00
PVY 50 S	50	55.10	48.00

contact surface finish: selective gold-plated

A

B

C

D

E

F

G

H

I

K

L

M

N

Accessories for flat ribbon cable and application tools

Flat ribbon cable - spacing 2,54 mm - suitable for connectors FV, SBAU 1

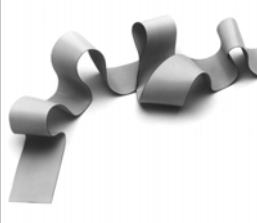
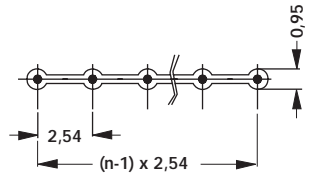
	
art. no.	no. of contacts
BK 01 32	32

Technical data:

current rating: 2 A; conductor resistance: ≤ 230 mΩ/m; capacitance: ≤ 65 pF/m symmetrical; wave impedance: 170 Ω symmetrical
 cross section: AWG 28/~0.089 mm²; conductor: 7 x Ø 0,127 mm; operating voltage: 300 V_{eff} max. operating temperature range: -30 ... +105 °C

Bench press

height without handle: 28 cm, weight: 9.02 kg

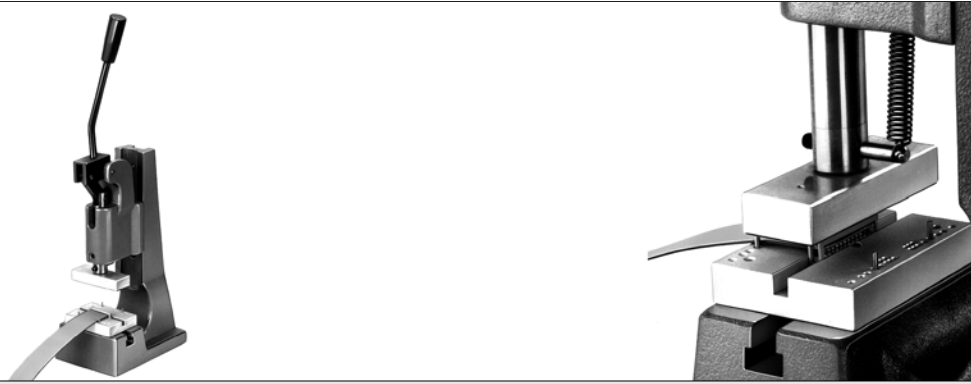
art. no.
VBK 1

The bench press VBK 1 connects all contacts of IDC connector types KK, SB, FV, PV, PVZ and VFL in one simple operation.

By piercing through the insulation, the contacts form, due to their conception, a gas-tight and corrosion-proof connection.

Accessories, suitable for strip-line connector

art. no.	suitable for male connectors and female headers
KK W	KK
SB W	SB
PV W	PV, VFL, FLMP
PVY W	PVY
D W 9 37	D-Sub (9-37 contacts)

Removable locating frames for every indicated type available.

Male headers manual soldering

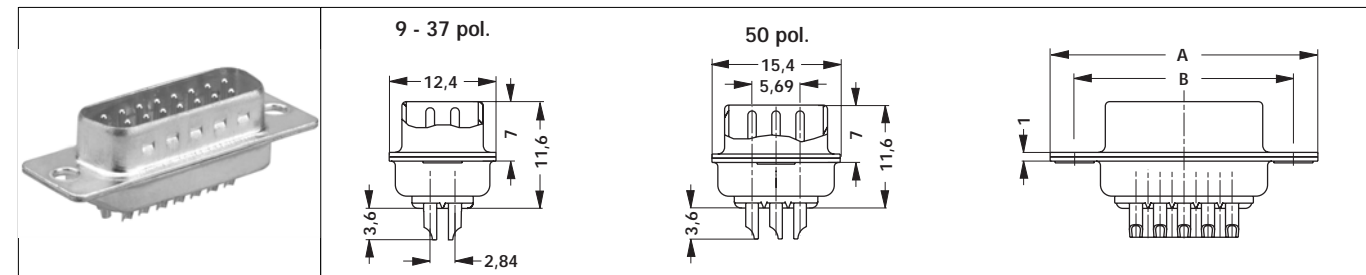

art. no.	no. of contacts	contact	connection type	dim. [mm]	
				A	B
DS 09 L	9	male	manual soldering	30.80	25.00
DS 15 L	15	male	manual soldering	39.20	33.30
DS 25 L	25	male	manual soldering	53.10	47.00
DS 37 L	37	male	manual soldering	69.50	63.50
DS 50 L	50	male	manual soldering	67.00	61.10

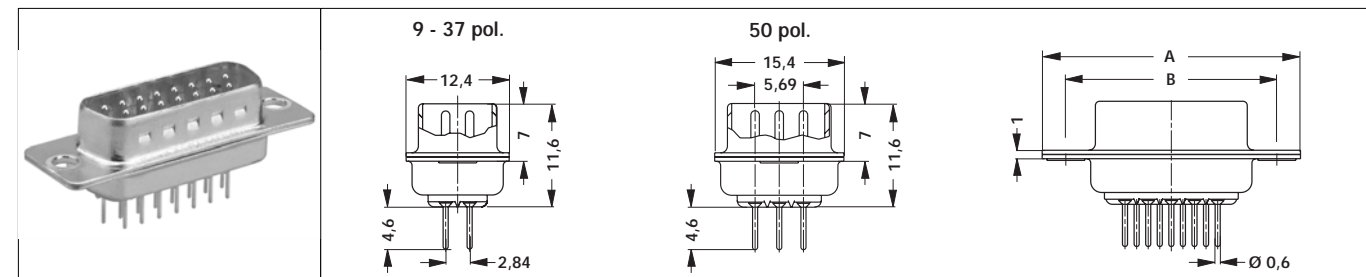

art. no.	no. of contacts	contact	connection type	dim. [mm]	
				A	B
DS 09 T	9	male	dip soldering	30.80	25.00
DS 15 T	15	male	dip soldering	39.20	33.30
DS 25 T	25	male	dip soldering	53.10	47.00
DS 37 T	37	male	dip soldering	69.50	63.50
DS 50 T	50	male	dip soldering	67.00	61.10

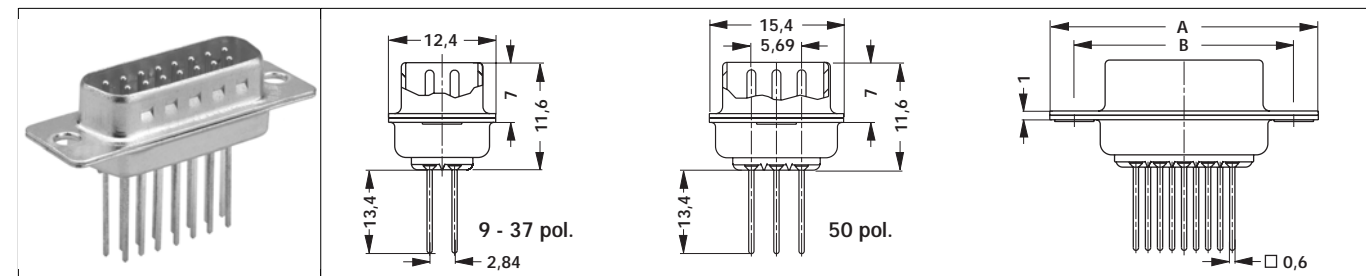

art. no.	no. of contacts	contact	connection type	dim. [mm]	
				A	B
DS 09 WW 3	9	male	wire wrap	30.80	25.00
DS 15 WW 3	15	male	wire wrap	39.20	33.30
DS 25 WW 3	25	male	wire wrap	53.10	47.00
DS 37 WW 3	37	male	wire wrap	69.50	63.50
DS 50 WW 3	50	male	wire wrap	67.00	61.10

A

B

C

D

E

F

G

H

I

K

L

M

N

D-Sub standard connectors

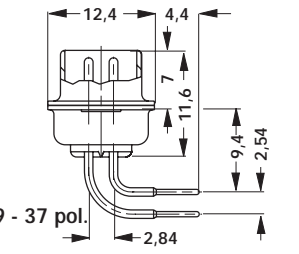
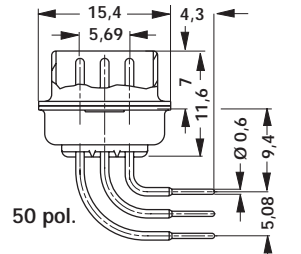
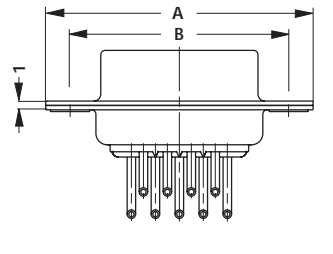
						
	art. no.	no. of contacts	contact	connection type	dim. [mm]	
DS 37 LA	37	male	90° angled	A	B	
DS 50 LA	50	male	90° angled	69.50	63.50	
				67.00	61.10	

cases: tin-plated
With turned precision contacts. The screened version.

Female headers manual soldering

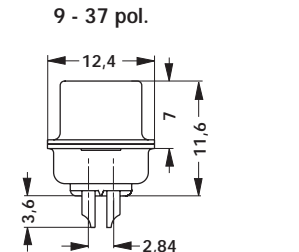
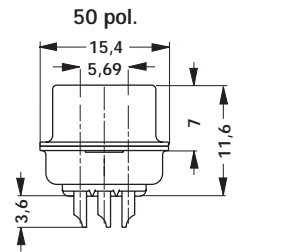
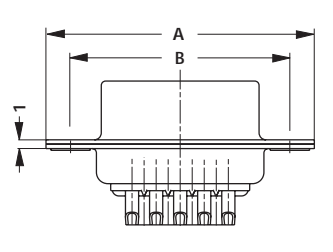
						
	art. no.	no. of contacts	contact	connection type	dim. [mm]	
DB 09 L	9	female	manual soldering	A	B	
DB 15 L	15	female	manual soldering	30.80	25.00	
DB 25 L	25	female	manual soldering	39.20	33.30	
DB 37 L	37	female	manual soldering	53.10	47.00	
DB 50 L	50	female	manual soldering	69.50	63.50	
				67.00	61.10	

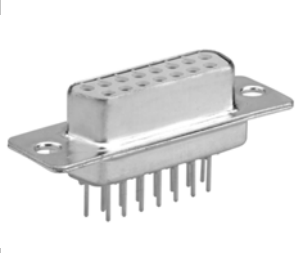
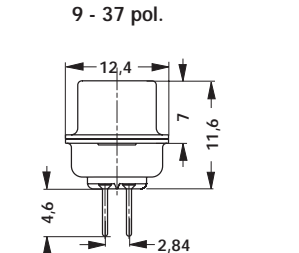
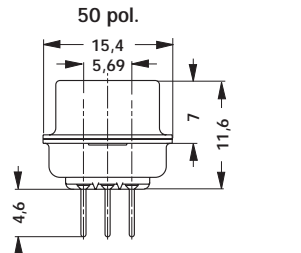
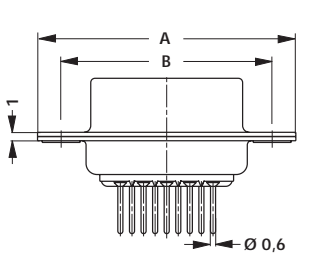
						
	art. no.	no. of contacts	contact	connection type	dim. [mm]	
DB 09 T	9	female	dip soldering	A	B	
DB 15 T	15	female	dip soldering	30.80	25.00	
DB 25 T	25	female	dip soldering	39.20	33.30	
DB 37 T	37	female	dip soldering	53.10	47.00	
DB 50 T	50	female	dip soldering	69.50	63.50	
				67.00	61.10	

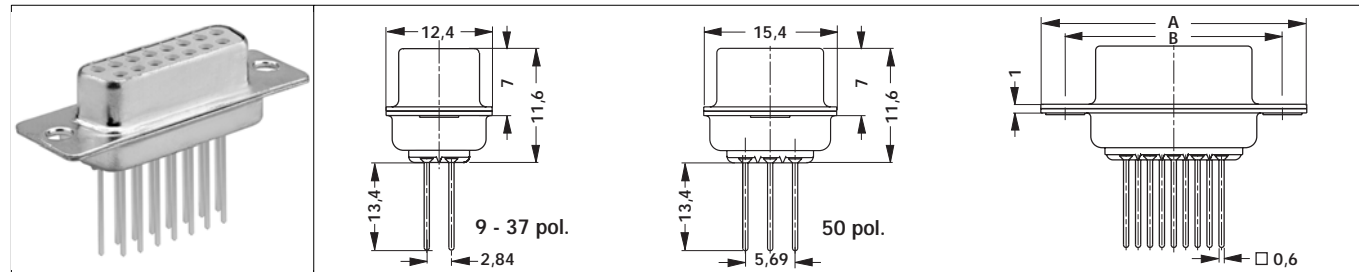

art. no.	no. of contacts	contact	connection type	dim. [mm]	
				A	B
DB 09 WW 3	9	female	wire wrap	30.80	25.00
DB 15 WW 3	15	female	wire wrap	39.20	33.30
DB 25 WW 3	25	female	wire wrap	53.10	47.00
DB 37 WW 3	37	female	wire wrap	69.50	63.50
DB 50 WW 3	50	female	wire wrap	67.00	61.10

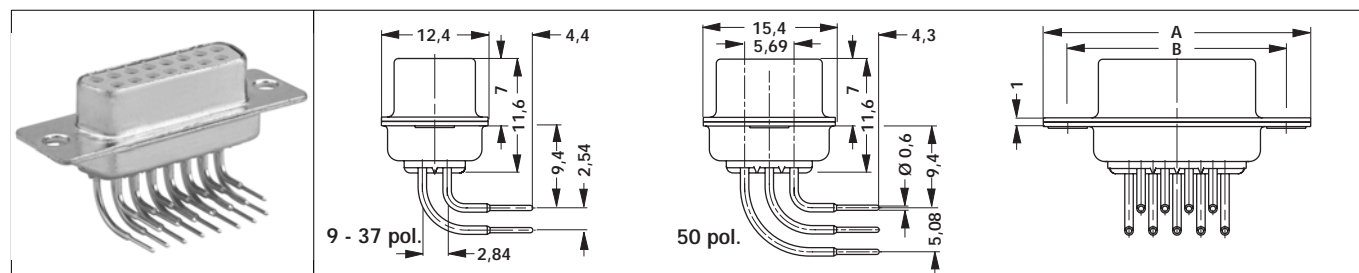

art. no.	no. of contacts	contact	connection type	dim. [mm]	
				A	B
DB 25 LA	25	female	90° angled	53.10	47.00
DB 37 LA	37	female	90° angled	69.50	63.50
DB 50 LA	50	female	90° angled	67.00	61.10

cases: tin-plated

With turned precision contacts. The screened version.

Einbaudarstellung

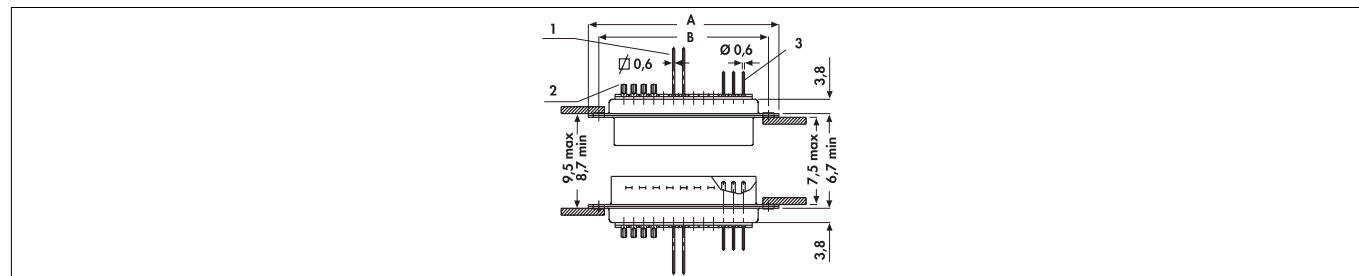

- 1 = wire wrap pin
- 2 = solder terminal
- 3 = solder pin for PCB

Screw fastening
D-Sub mixed layout
D-Sub w. mount. bracket

→ I 28
→ I 13 - 14
→ I 5 - 6

D-Sub connectors /flat cable
Technical data

→ I 11
→ I 29 - 30

D-Sub standard connectors with mounting bracket

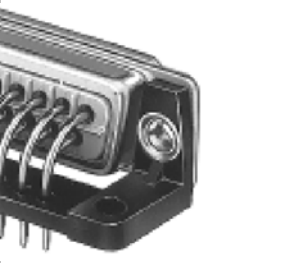
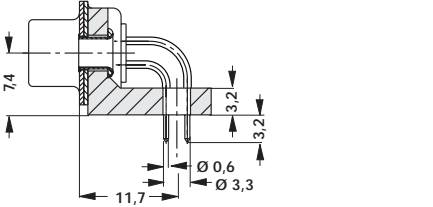
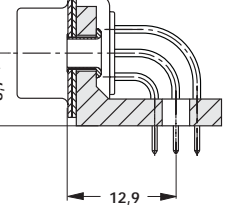
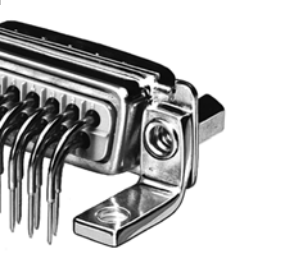
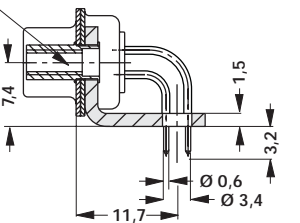
	<div style="display: flex; justify-content: space-around;"> <div style="text-align: center;"> <p>9 - 37 pol.</p>  </div> <div style="text-align: center;"> <p>50 pol.</p>  </div> </div>				
<p>art. no. DB WK 9</p>	<table border="1" style="width: 100%;"> <tr> <td style="width: 15%;">contact</td> <td style="width: 85%;">mounting angle</td> </tr> <tr> <td>female</td> <td>plastic angle, riveted</td> </tr> </table>	contact	mounting angle	female	plastic angle, riveted
contact	mounting angle				
female	plastic angle, riveted				
	<div style="text-align: center;"> <p>UNC 4-40</p>  </div>				
<p>art. no. DS WMV 4 ...</p>	<table border="1" style="width: 100%;"> <tr> <td style="width: 15%;">contact</td> <td style="width: 85%;">mounting angle</td> </tr> <tr> <td>male</td> <td>metal angle with screw fastening, thread UNC 4-40</td> </tr> </table>	contact	mounting angle	male	metal angle with screw fastening, thread UNC 4-40
contact	mounting angle				
male	metal angle with screw fastening, thread UNC 4-40				
<p>DB WMV 4 ...</p>	<table border="1" style="width: 100%;"> <tr> <td style="width: 15%;">contact</td> <td style="width: 85%;">mounting angle</td> </tr> <tr> <td>female</td> <td>metal angle with screw fastening, thread UNC 4-40</td> </tr> </table>	contact	mounting angle	female	metal angle with screw fastening, thread UNC 4-40
contact	mounting angle				
female	metal angle with screw fastening, thread UNC 4-40				
<p>please indicate: ... no. of contacts 9, 25</p>					

A

B

C

D

E

F

G

H

I

K

L

M

N

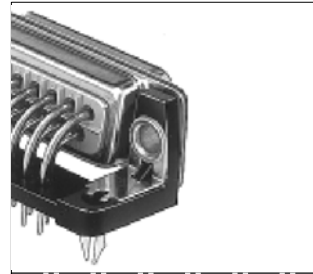
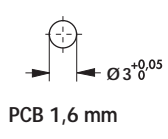
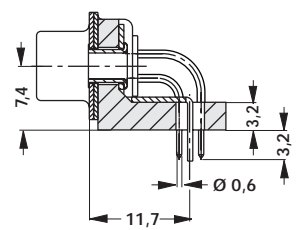
		
art. no.	contact	mounting angle
DS WR ...	male	plastic angle with earthing plate and snap-on clip
DB WR ...	female	plastic angle with earthing plate and snap-on clip
please indicate: ... no. of contacts 25, 37		

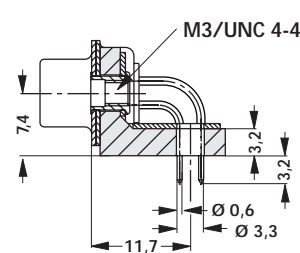
		
art. no.	contact	mounting angle
DS WE 3 ...	male	plastic angle with earthing plate and threaded rivet M3
DS WE 4 ...	male	plastic angle with earthing plate and threaded rivet UNC 4-40
DB WE 3 ...	female	plastic angle with earthing plate and threaded rivet M3
DB WE 4 ...	female	plastic angle with earthing plate and threaded rivet UNC 4-40
please indicate: ... no. of contacts 9, 15, 25, 37		

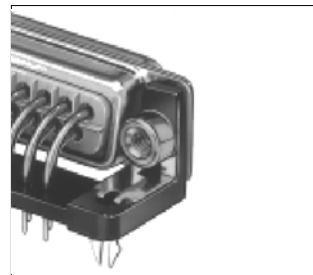
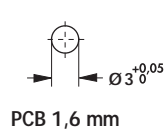
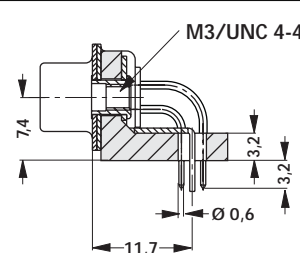
		
art. no.	contact	mounting angle
DS WR 3 ...	male	plastic angle with earthing plate, snap-on clip and threaded rivet M3
DS WR 4 ...	male	plastic angle with earthing plate, snap-on clip & threaded rivet UNC 4-40
DB WR 3 ...	female	plastic angle with earthing plate, snap-on clip and threaded rivet M3
DB WR 4 ...	female	plastic angle with earthing plate, snap-on clip & threaded rivet UNC 4-40
please indicate: ... no. of contacts 9, 15, 25, 37		

Male headers

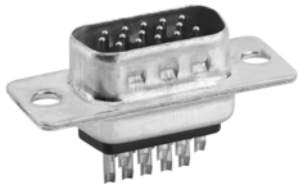
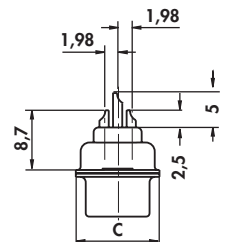
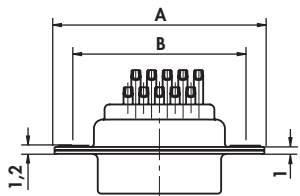
								
	art. no.	no. of contacts	contact	dim. [mm]				
HD S 15 L	15	male	A	B	C	D	E (max.)	F
HD S 26 L	26	male	30.60	25.00	12.20	7.10	7.60	2.29
HD S 44 L	44	male	39.00	33.30	12.20	6.80	7.00	2.29
			52.80	47.00	12.20	7.00	6.80	2.29

cases: tin-plated; kind of terminal: manual soldering

With turned precision contacts. The screened version.

Female headers

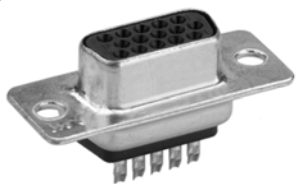
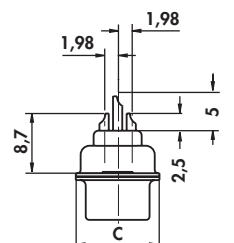
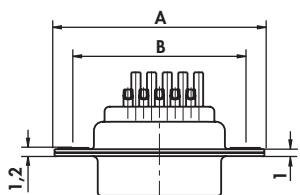
								
	art. no.	no. of contacts	contact	dim. [mm]				
HD B 15 L	15	female	A	B	C	D	E (max.)	F
HD B 26 L	26	female	30.80	25.00	12.20	7.60	7.10	2.29
HD B 44 L	44	female	39.20	33.30	12.20	7.00	6.80	2.29
			53.00	47.00	12.20	6.80	7.00	2.29

cases: tin-plated; kind of terminal: manual soldering

With turned precision contacts. The screened version.

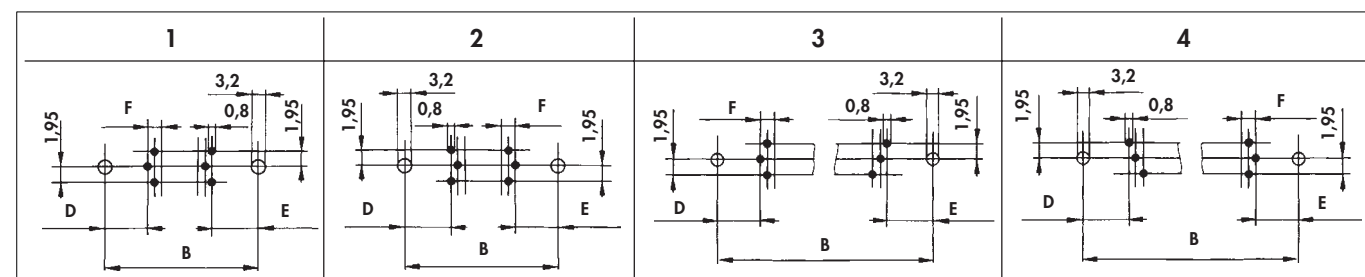

1 = male, 15 contacts; 2 = female, 15 contacts
 3 = male, 26/44 contacts; 4 = female, 26/44 contacts

Male headers

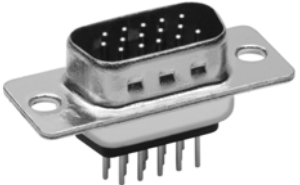
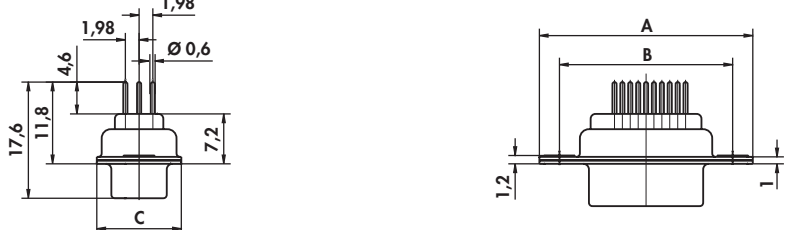
								
art. no.	no. of contacts	contact	dim. [mm]					
HD S 15 T	15	male	A	B	C	D	E (max.)	F
			30.60	25.00	12.20	7.10	7.60	2.29

cases: tin-plated; kind of terminal: dip soldering

With turned precision contacts. The screened version.

Female headers

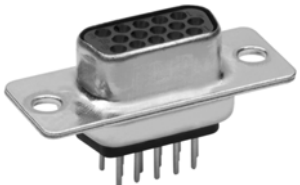
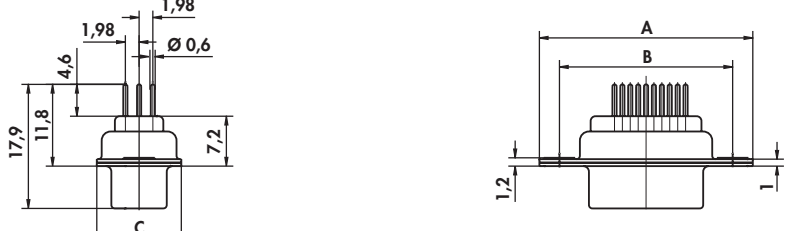
								
art. no.	no. of contacts	contact	dim. [mm]					
HD B 15 T	15	female	A	B	C	D	E (max.)	F
HD B 26 T	26	female	39.20	33.30	12.20	7.00	6.80	2.29

cases: tin-plated; kind of terminal: dip soldering

With turned precision contacts. The screened version.

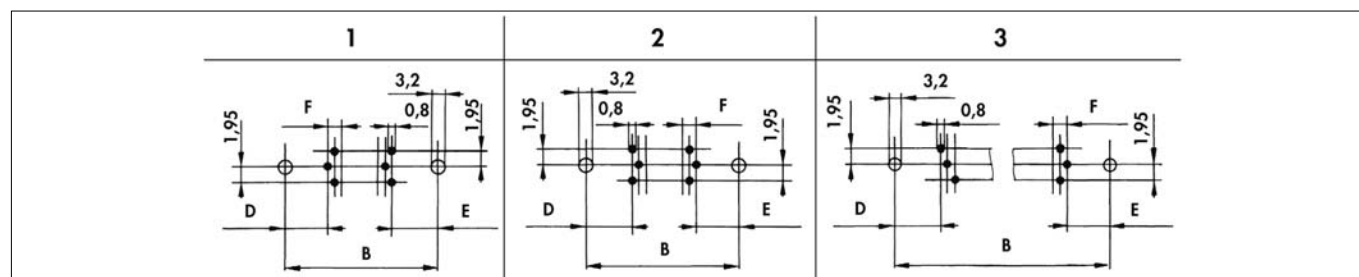

1 = male, 15 contacts; 2 = female, 15 contacts; 3 = female, 26 contacts

Technical data → I 29 - 30
 Screw fastening → I 28
 D-Sub connectors /flat cable → I 11

High-prec.male head.in SMD mount. → G 35
 Accessories for HF → I 29
 D-Sub cut-out cover → I 27

D-Sub filter connector

Adapter, 9-37 contacts

capacity per contact: 1000 pF

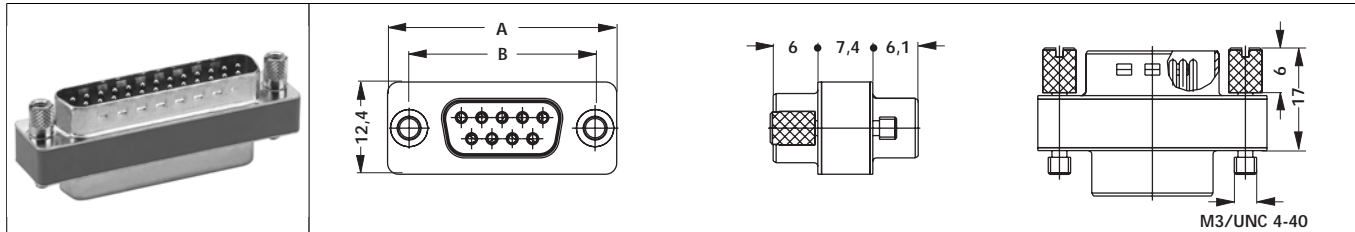

art. no.	no. of contacts	type of thread	dim. [mm]	
			A	B
FD A ... 09 1000	9	3	30.80	25.00
FD A ... 15 1000	15	3	39.20	33.30
FD A ... 25 1000	25	3	53.10	47.00
FD A ... 37 1000	37	3	69.50	63.50

please indicate:

... **type of thread**
3 = M 3
4 = UNC 4-40

Standard installation dimensions.
 HF-tight, stud bolt mountable on both sides.
 Compatible with standard accessories.

Male headers, mit Lötkelch

capacity per contact: 1000 pF - other components on request; geeignet für Kabel AWG 22

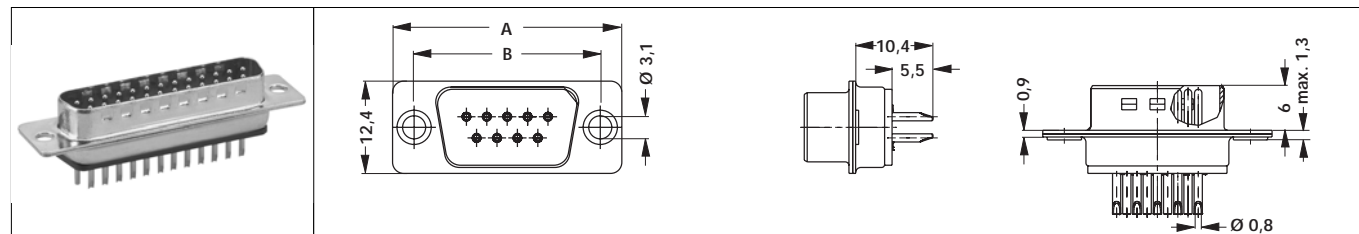

art. no.	no. of contacts	contact	dim. [mm]	
			A	B
FD S 09 L 1000	9	male	30.80	25.00
FD S 15 L 1000	15	male	39.20	33.30
FD S 25 L 1000	25	male	53.10	47.00
FD S 37 L 1000	37	male	69.50	63.50

Standard installation dimensions.

HF-tight, closed metal rear panel.

Compatible with standard accessories.

Female headers, mit Lötkelch

capacity per contact: 1000 pF - other components on request; geeignet für Kabel AWG 22

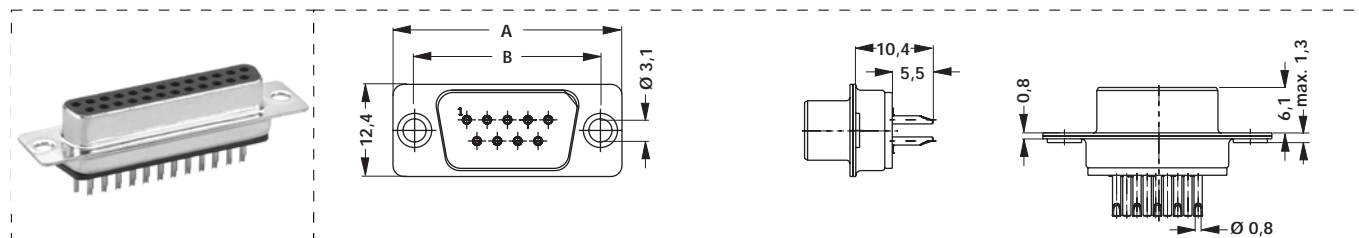

art. no.	no. of contacts	contact	dim. [mm]	
			A	B
FD B 09 L 1000	9	female	30.80	25.00
FD B 15 L 1000	15	female	39.20	33.30
FD B 25 L 1000	25	female	53.10	47.00
FD B 37 L 1000	37	female	69.50	63.50

Standard installation dimensions.

HF-tight, closed metal rear panel.

Compatible with standard accessories.

A

B

C

D

E

F

G

H

I



K

L

M

N

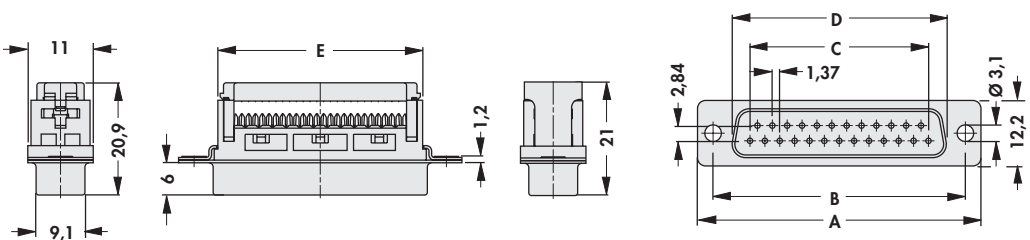
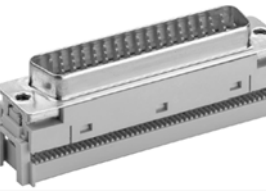
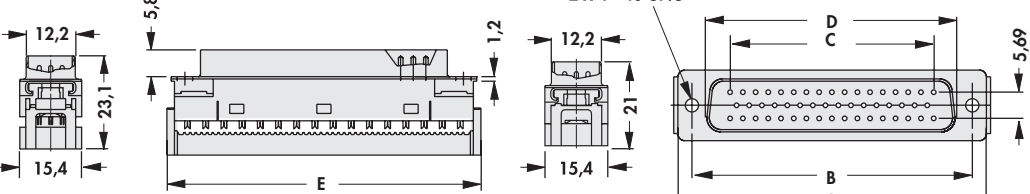
Male headers and female headers

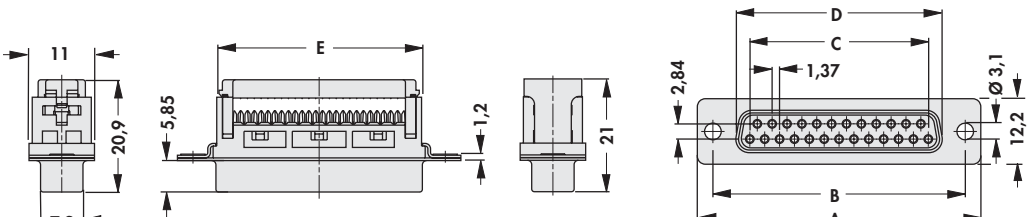
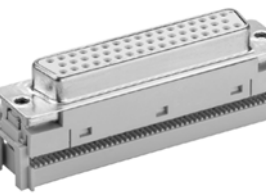
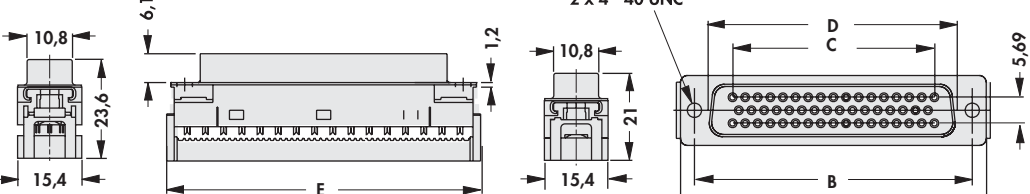
							
art. no.	no. of contacts	contact	dim. [mm]				
DS BK 09	9	male	A	B	C	D	E (max.)
DS BK 15	15	male	30.60	25.00	10.96	17.90	16.10
DS BK 25	25	male	39.00	33.30	19.33	26.20	23.90
DS BK 37	25	male	52.80	47.00	33.13	39.90	38.10
DS BK 37	37	male	69.20	63.50	49.70	56.30	54.70
							
art. no.	no. of contacts	contact	dim. [mm]				
DS BK 50	50	male	A	B	C	D	E (max.)
			66.80	61.10	44.20	54.00	68.60
							
art. no.	no. of contacts	contact	dim. [mm]				
DB BK 09	9	female	A	B	C	D	E (max.)
DB BK 15	15	female	30.60	25.00	10.96	16.30	16.10
DB BK 25	25	female	39.00	33.30	19.33	24.50	23.90
DB BK 37	25	female	52.80	47.00	33.13	38.50	38.10
DB BK 37	37	female	69.20	63.50	49.70	54.80	54.70
							
art. no.	no. of contacts	contact	dim. [mm]				
DB BK 50	50	female	A	B	C	D	E (max.)
			66.80	61.10	44.20	52.40	68.60

Male headers, low profile

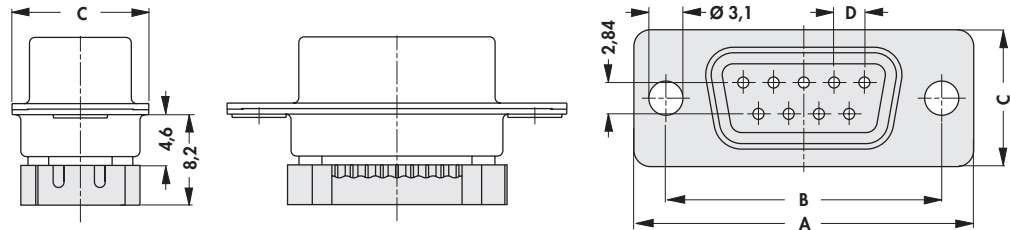
						
	art. no.	no. of contacts	contact	dim. [mm]		
DS BK 09 LP	9	male	A	B	C	D
DS BK 15 LP	15	male	30.80	25.00	12.40	2.74
DS BK 25 LP	25	male	39.20	33.30	12.40	2.74
DS BK 25 LP	25	male	53.10	47.00	12.40	2.77
DS BK 37 LP	37	male	69.50	63.50	12.40	2.77

useable ribbon cable: AWG 26 - 28

Female headers, low profile

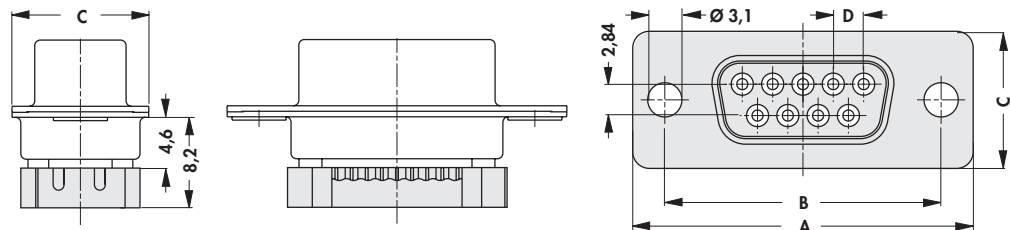
						
	art. no.	no. of contacts	contact	dim. [mm]		
DB BK 09 LP	9	female	A	B	C	D
DB BK 25 LP	25	female	30.80	25.00	12.40	2.74
DB BK 25 LP	25	female	53.10	47.00	12.40	2.77
DB BK 37 LP	37	female	69.50	63.50	12.40	2.77

useable ribbon cable: AWG 26 - 28

A

B

C

D

E

F

G

H

I

K

L

M

N

Male headers - suitable for standard D-Sub accessories

3 high current contacts

<p>art. no. DSM 3K3 L20</p>	<p>contact male</p>

2 high current contacts, 5 signal contacts

<p>art. no. DSM 7K2 L20</p>	<p>contact male</p>

3 high current contacts, 10 signal contacts

<p>art. no. DSM 13K3 L20</p>	<p>contact male</p>

Gold-plated contacts.

With high current contacts up to 20 A.

For cables up to AWG 16.

Female headers - suitable for standard D-Sub accessories

3 high current contacts

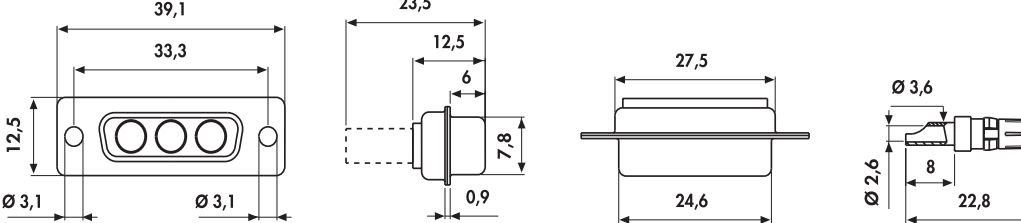
	
art. no. DBM 3K3 L20	contact female

2 high current contacts, 5 signal contacts

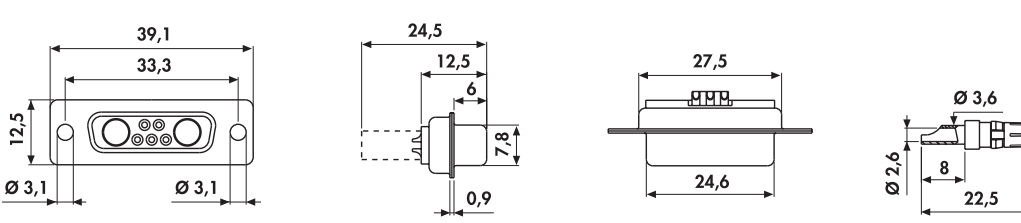
	
art. no. DBM 7K2 L20	contact female

3 high current contacts, 10 signal contacts

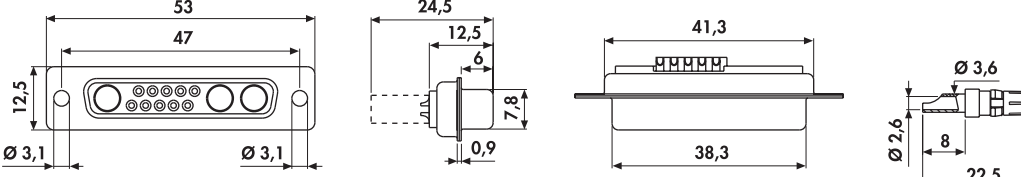
	
art. no. DBM 13K3 L20	contact female

Gold-plated contacts.

With high current contacts up to 20 A.

For cables up to AWG 16.

A

B

C

D

E

F

G

H

I

K

L

M

N



D-Sub in SMD-mounting

Male headers

	art. no.	no. of contacts	dim. [mm]		
		A	B	Y	Z
DS 09 SMD TR	9	30.80	25.00	10.98	1.37
DS 15 SMD TR	15	39.20	33.30	19.20	1.37
DS 25 SMD TR	25	53.10	47.00	33.12	1.38
DS 37 SMD TR	37	69.50	63.50	49.68	1.38

packing: tape and reel (150 pcs/reel); reel outer diameter 330 mm

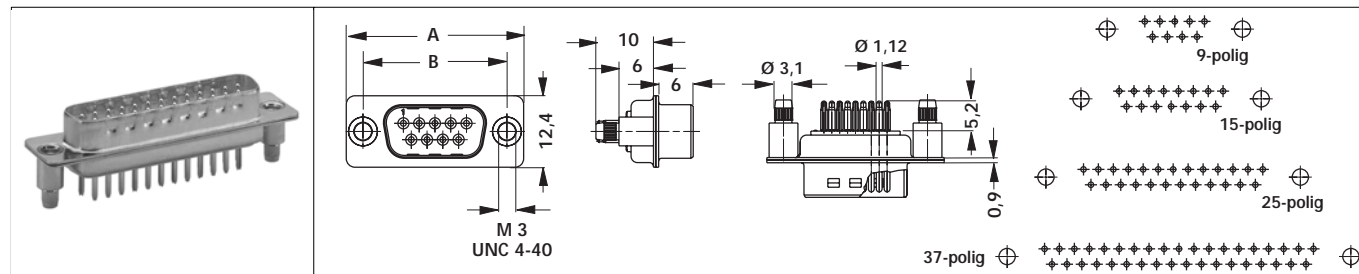

art. no.	no. of contacts	type of thread	dim. [mm]	
			A	B
DS ... 9 P	9	3	30.80	25.00
DS ... 15 P	15	3	39.20	33.30
DS ... 25 P	25	3	53.10	47.00
DS ... 37 P	37	3	69.50	63.50

please indicate: ... type of thread
 3 = M 3
 4 = UNC 4-40

A

B

C

D

E

F

G

H

I

K

L

M

N

Female headers

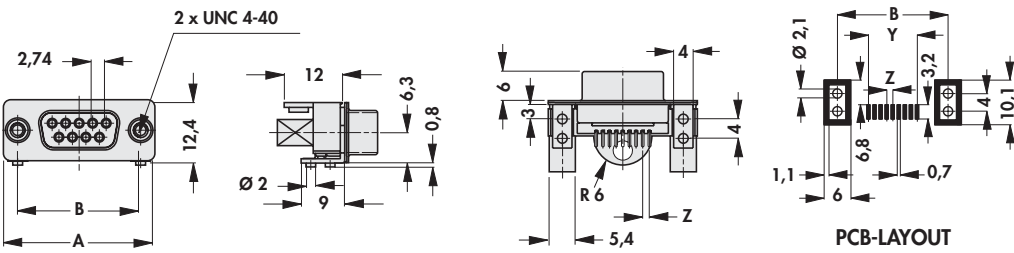
					
	art. no.	no. of contacts	dim. [mm]		
DB 09 SMD TR	9	A 30.80	B 25.00	Y 10.98	Z 1.37
DB 15 SMD TR	15	39.20	33.30	19.20	1.37
DB 25 SMD TR	25	53.10	47.00	33.12	1.38
DB 37 SMD TR	37	69.50	63.50	49.68	1.38

packing: tape and reel (150 pcs/reel); reel outer diameter 330 mm

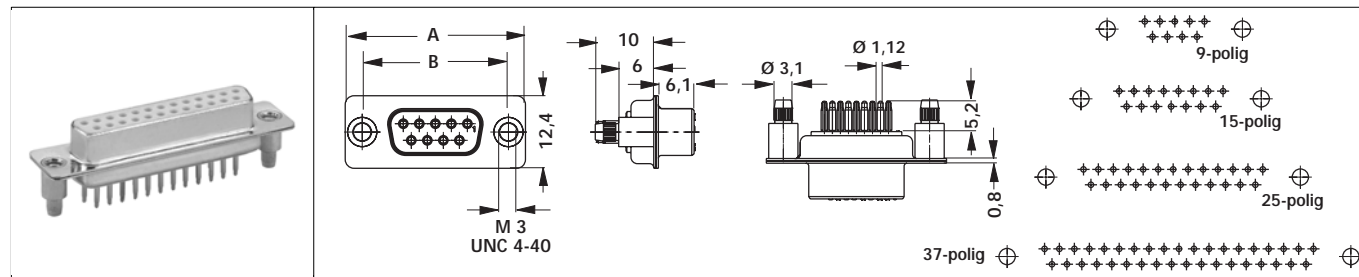

art. no.	no. of contacts	type of thread	dim. [mm]	
			A	B
DB ... 9 P	9	3	30.80	25.00
DB ... 15 P	15	3	39.20	33.30
DB ... 25 P	25	3	53.10	47.00
DB ... 37 P	37	3	69.50	63.50

please indicate: ... type of thread
 3 = M 3
 4 = UNC 4-40

A

B

C

D

E

F

G

H

I

K

L

M

N

D-Sub hoods, standard

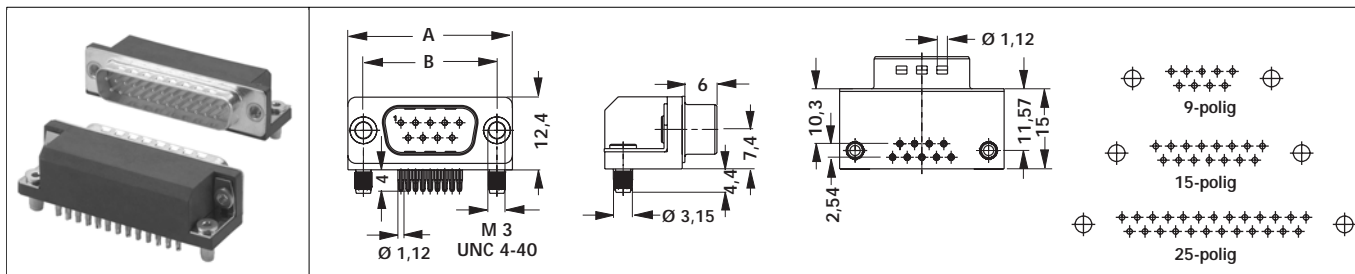

art. no.	no. of contacts	type of thread	dim. [mm]	
			A	B
DS WP ... 9	9	3	30.80	25.00
DS WP ... 15	15	3	39.20	33.30
DS WP ... 25	25	3	53.10	47.00
DS WP ... 37	37	3	69.50	63.50

please indicate: ... type of thread
3 = M 3
4 = UNC 4-40

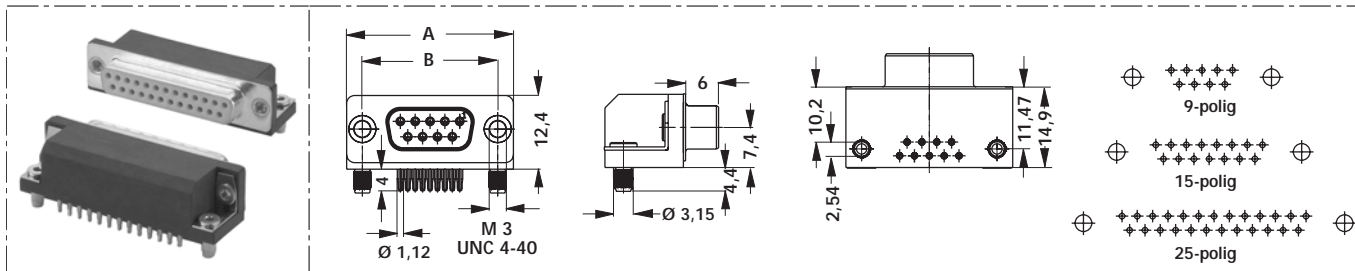

art. no.	no. of contacts	type of thread	dim. [mm]	
			A	B
DB WP ... 9	9	3	30.80	25.00
DB WP ... 15	15	3	39.20	33.30
DB WP ... 25	25	3	53.10	47.00
DB WP ... 37	37	3	69.50	63.50

please indicate: ... type of thread
3 = M 3
4 = UNC 4-40

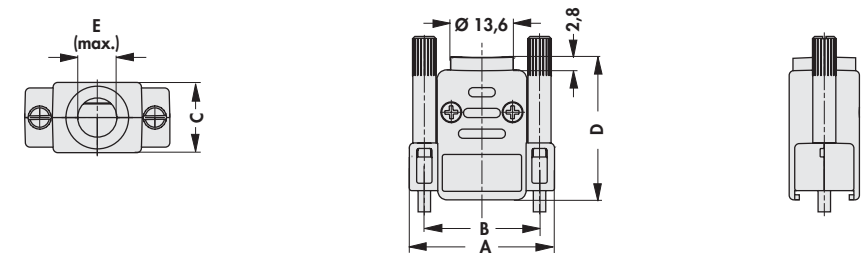
						
art. no.	no. of contacts	dim. [mm]				
		E (max.)	A	B	C	D
DH 09 ...	9	8.50	31.50	25.00	15.20	31.00
please indicate:		... case surface:				
		S = plastic, black				
		M = plastic, metallized				

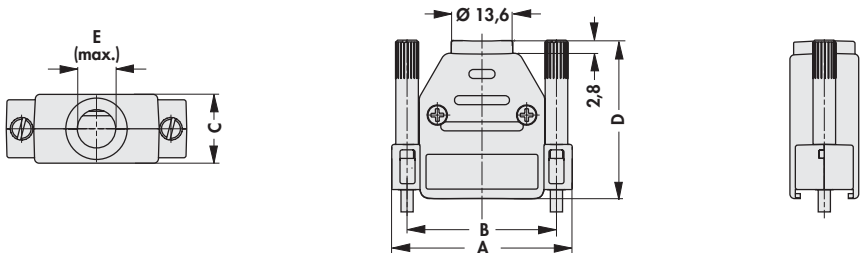
						
art. no.	no. of contacts	dim. [mm]				
		E (max.)	A	B	C	D
DH 15 ...	15	8.50	40.00	33.30	15.20	33.50
DH 25 ...	25	11.00	53.50	47.00	15.20	38.00
DH 37 ...	37	11.00	70.00	63.50	15.20	40.00
DH 50 ...	50	12.00	67.50	61.10	18.20	40.00
please indicate:		... case surface:				
		S = plastic, black				
		M = plastic, metallized				

E = max. diameter of the bushing in mm

Threaded bolt UNC 4-40. Large cable space with few components.

version: 9-37 can be mounted in series in 3 HP grid, thus especially suitable for 19" technology.

plastic material according: to UL 94:V-0

Suitable cable bushing

Protects the cable against damage by buckling.

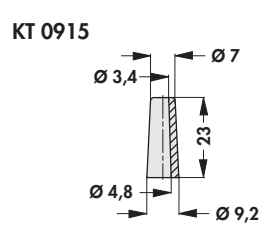
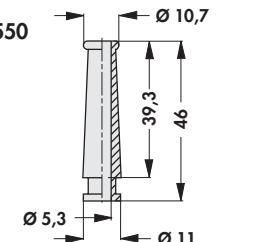
		
art. no.	for no. of contacts	
KT 0915	9, 15	
KT 2550	25, 37, 50	

D-Sub hoods, standard

With self-cutting threaded bolt

straight cable outlet with pre-assembled strain relief

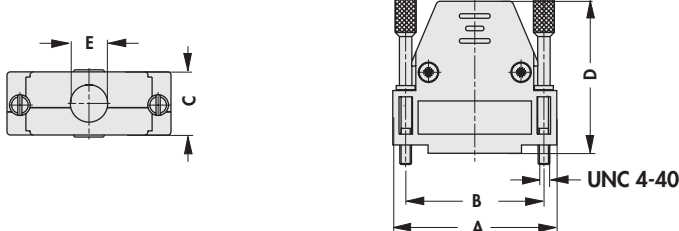
						
art. no.	no. of contacts	dim. [mm]				
		E (max.)	A	B	C	D
DH SG 09 ...	9	8.00	31.00	25.00	16.00	35.60
DH SG 15 ...	15	9.00	39.50	33.30	16.00	36.60
DH SG 25 ...	25	10.00	53.00	47.00	16.00	41.00
DH SG 37 ...	37	11.00	69.50	63.50	16.00	45.30
DH SG 50 ...	50	14.00	67.00	61.10	19.80	51.40
<p>please indicate:</p>		<p>... case surface: S = plastic, black M = plastic, metallized</p>				

material: thermoplastic ABS

D-Sub hoods with quick-action locking system

straight and side-gated cable outlet

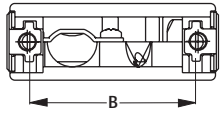
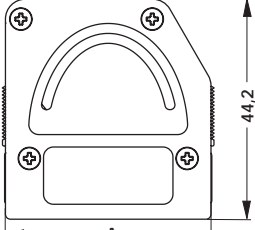
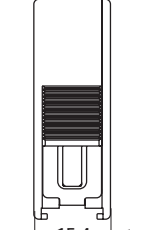
			
art. no.	no. of contacts	dim. [mm]	
		A	B
DH SV 09 S	9	33.00	25.00
DH SV 15 S	15	41.30	33.30
DH SV 25 S	25	55.00	47.00

option: metallised surface on request

material: thermoplastic ABS

Accessories – latch pin for hood – hood connection

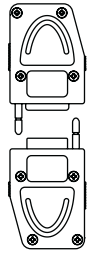
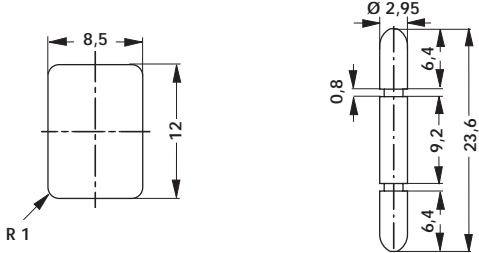
		
art. no.		
RS HH		

Accessories – latch pin for plug connector – hood connection

latch pin for connectors with thread M3 / UNC 4-40

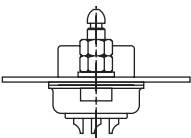
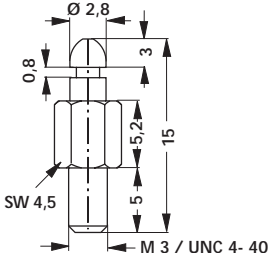
		
art. no.	type of thread	
RS SH 3	M 3	
RS SH 4	UNC 4-40	

A

B

C

D

E

F

G

H

I

K

L

M

N

Accessories – latch pin for plug connector – hood connection

latch pin for existing connector with through hole

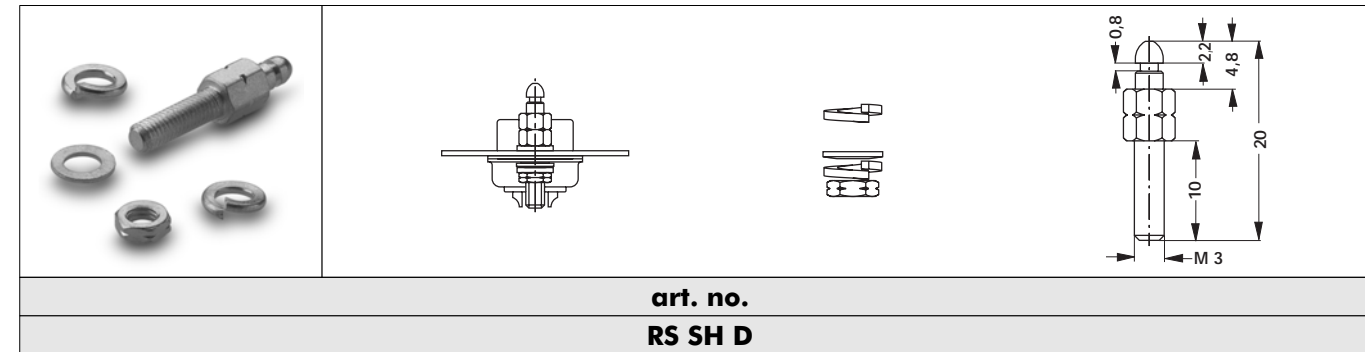

Cable sleeve - quick-acting closure hood DH SV ...

for cable diameters 3-9 mm

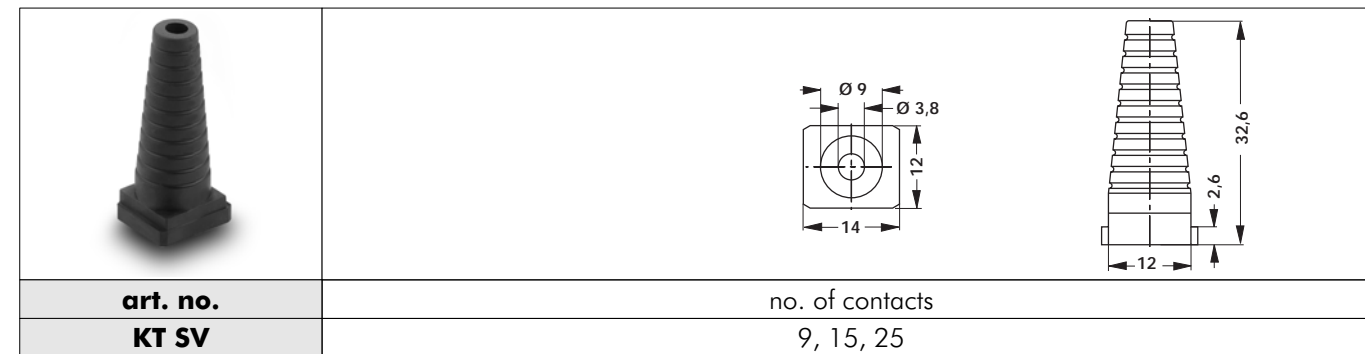

Cable sleeves are supplied with chamfers, which are adequate to a diameter-grading of 0.5 mm. They can be cut off depending on the existing diameter of the cable.

flammability: UL 94 HB

9-50 pins

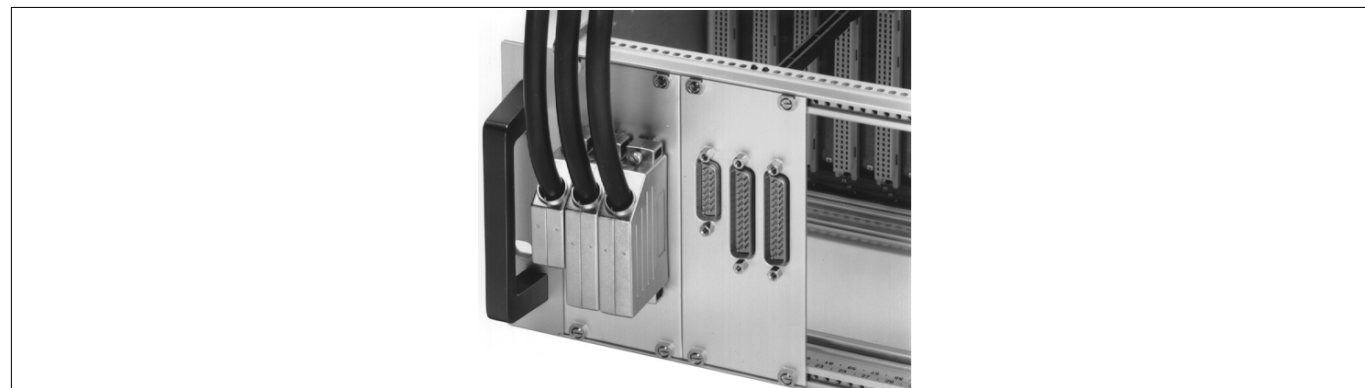

Width C - 3 HP

version: 9-37 pins can be mounted in series in 3 HP grid, thus especially suitable for 19" technology

plastic material: according to UL 94 V-0

Metallized version with excellent shielding against electrical and magnetic alternating fields.

2-at side cable outputs (25-50 pins).

40° opening, open (9-50 pins). 90° opening, covered (25-50 pins).

Integrated dust protective shroud.

Captive latching screws with UNC 4-40 treads.

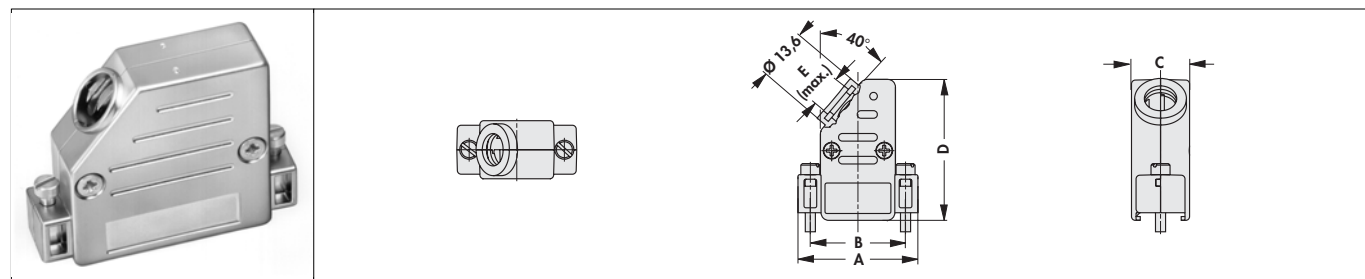

art. no.	no. of contacts	dim. [mm]				
		A	B	C	D	E (max.)
DH 09 ...	9	31.50	25.00	15.20	37.00	8.50
DH 15 ...	15	40.00	33.30	15.20	37.00	8.50
DH 25 ...	25	53.50	47.00	15.20	41.00	11.00
DH 37 ...	37	70.00	63.50	15.20	41.00	11.00
DH 50 ...	50	67.80	61.10	18.20	41.00	12.00

please indicate: ... case surface:
K = plastic, black
KM = plastic, metallized

E = max. diameter of the bushing in mm

D-Sub cover for flat cable

D-Sub cover for flat cable, 9-25 contacts

for D-Sub connectors DS BK ... and DB BK ...

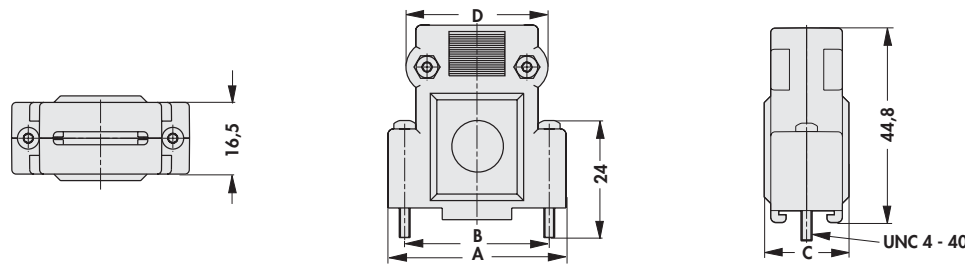
					
art. no.	no. of contacts	dim. [mm]			
		A	B	C	D
DH BK 09 ...	9	33.00	25.00	19.50	24.60
DH BK 25 ...	25	54.80	47.00	19.50	47.60
<p>please indicate:</p>		<p>... case surface: K = plastic, grey KM = plastic, metallized</p>			

material: ABS; Internal strain relief. Two-part plastic hood with UNC 4-40 screws.

Vertical cable clamp

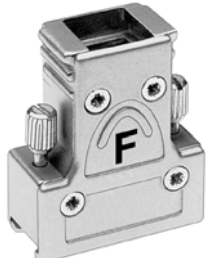
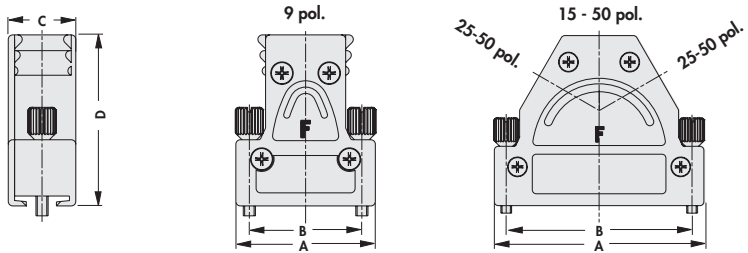
								
	art. no.	no. of contacts	cable clamps	crimp flange	crimp sleeve	dim. [mm]		
DH 09 VM	9	KKS 937	CF ...	CH ...	31.00	25.00	15.00	38.00
DH 15 VM	15	KKS 937	CF ...	CH ...	39.50	33.30	15.00	35.00
DH 25 VM	25	KKS 937	CF ...	CH ...	53.00	47.00	15.00	43.00
DH 37 VM	37	KKS 937	CF ...	CH ...	69.50	63.50	15.00	43.00
DH 50 VM	50	KKS 050	CF ...	CH ...	67.20	61.10	17.80	43.00

Lateral knurled screws with UNC 4-40 thread. Easy mounting due to pre-tapped thread.
HF-tight due to crimp flange CF ...

Accessories for D-Sub hoods made of full metal - screwable cable clamp

For clamping the screen and as strain relief.

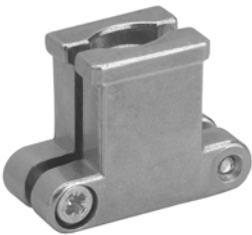
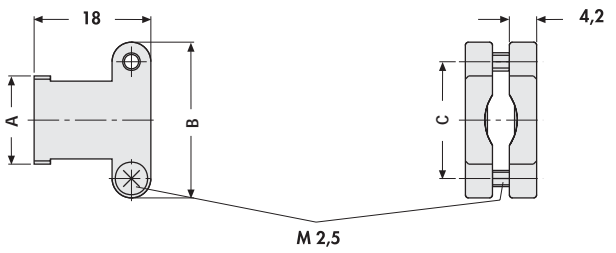
				
	art. no.	no. of contacts	dim. [mm]	
KKS 050	50	A	B	C
		19.80	25.00	19.00

A

B

C

D

E

F

G

H

I

K

L

M

N

Cover for D-Sub cut outs in front and backpanel

suitable for EMC application, closed one side

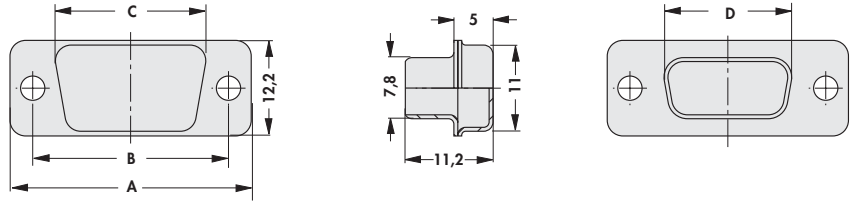
					
	art. no.	no. of contacts	dim. [mm]		
BADM 09	9	A	B	C	D
BADM 15	15	30.80	25.00	19.20	16.30
BADM 25	25	39.30	33.30	27.50	24.50
BADM 37	37	53.00	47.00	41.20	38.30
		69.40	63.50	57.70	54.80

surface metal case: tin-plated

Blank covers for exact sealing of unused D-Sub cut outs in front- and backpanels.
Size and form are as D-Sub housings.

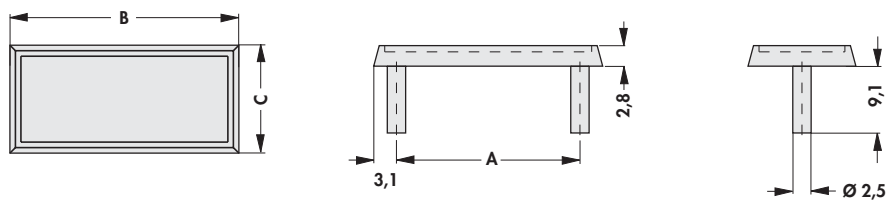
				
	art. no.	no. of contacts	dim. [mm]	
BADP 09	9	A	B	C
BADP 15	15	25.00	31.20	14.70
BADP 25	25	33.30	39.60	14.70
BADP 37	37	47.00	53.30	14.70
BADP 50	50	63.50	67.60	14.70

Plastic cover, blank, for blind D-Sub and other connector cutouts in front and rear panels.
Easy to mount with enclosed clamping springs.

- material: ABS
- flammability: UL 94 V-0
- colour: black
- clamping spring: steel

Screw fastening, mounted

2 screw fastenings incl. spacer, washer, nut

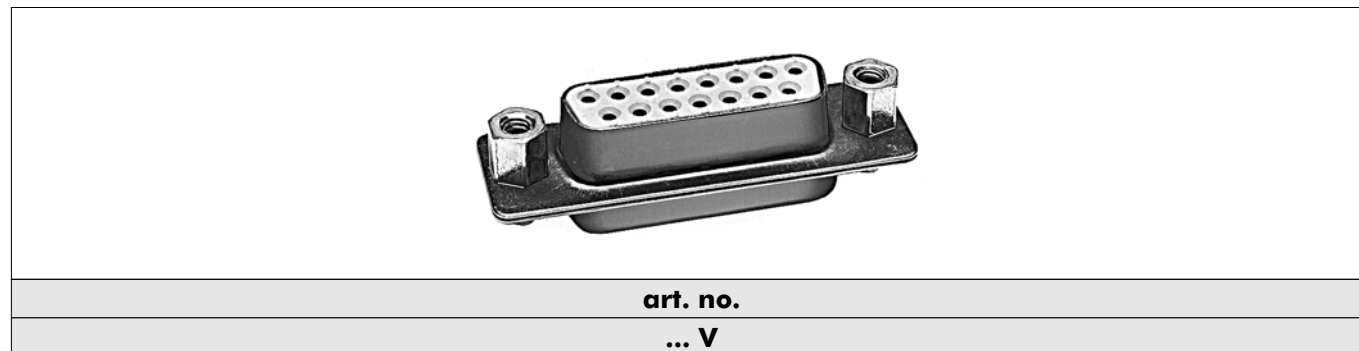

Please add a V to the corresponding art. no. ...

Screw fastening, loose

2 separate screw fasteners, with washer and nut

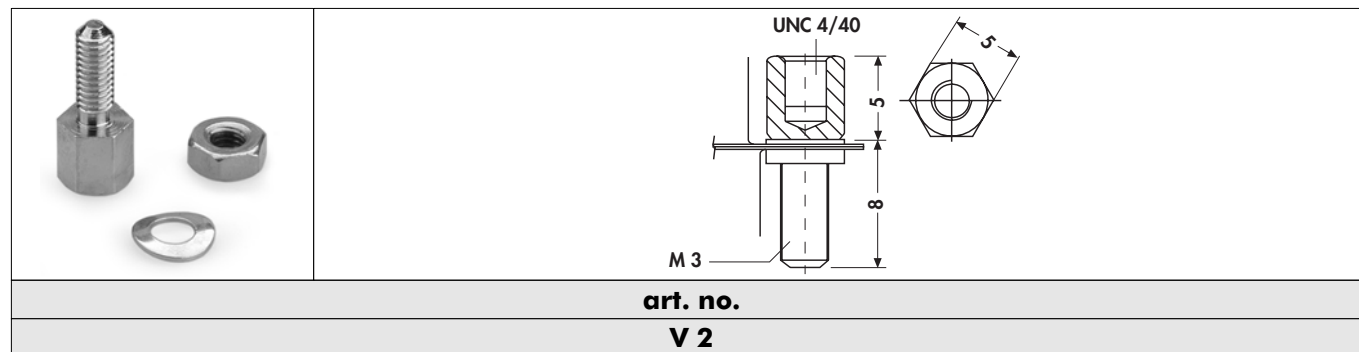

material:

screw - brass nickel-plated; **screw-nut** - steel nickel-plated; **washer** - steel tin-plated

Screw fastening for assembly of cases, separate

2 screw fastenings incl. spacer, washer, nut

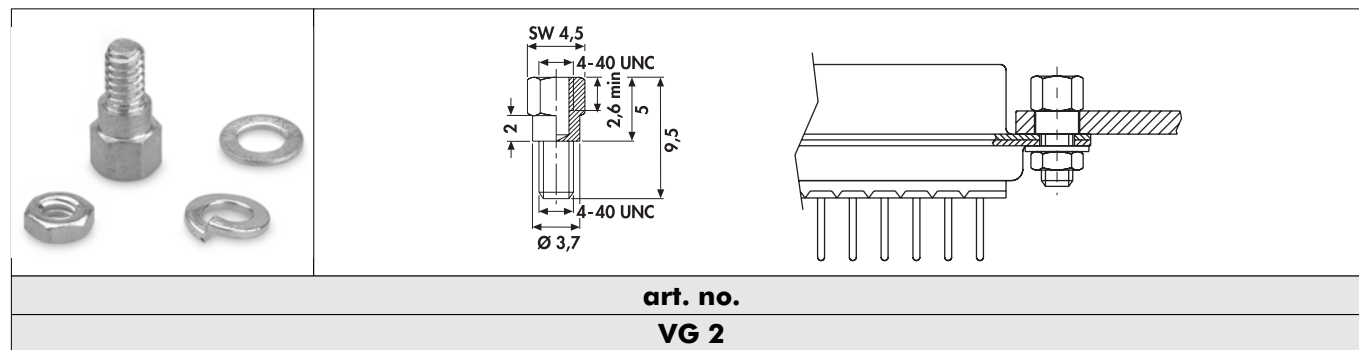

material:

screw and screw-nut - steel nickel-plated; **washer** - steel tin-plated

A

B

C

D

E

F

G

H

I

K

L

M

N

HF-tight caps, male headers and female headers

prevent HF-radiation at open interfaces

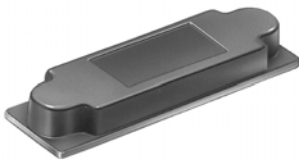
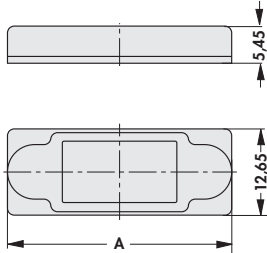
				
	art. no.	no. of contacts	colour	contact
HFK S 09	9	blue	male	32.90
HFK S 15	15	blue	male	41.30
HFK S 25	25	blue	male	55.70
HFK B 09	9	red	female	32.90
HFK B 15	15	red	female	41.30
HFK B 25	25	red	female	55.70

material: ABS plastics UL 94:V-0, nickel-plated on the inside

flammability: <1 Ω

temperature range: -25 °C ... +70 °C

HF-seals

as seal between plug and housing

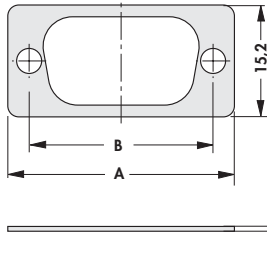
				
	art. no.	no. of contacts	dim. [mm]	
			A	B
HFD 09	9	30.80	25.00	
HFD 15	15	39.40	33.30	
HFD 25	25	53.40	47.00	
HFD 37	37	70.70	63.50	

material: silicone, filling of silvered copper particles

Extremely low contact resistance.

For male headers

art. no.	no. of contacts	dim. [mm]	
		A	B
SSK S 09	9	22.50	18.20
SSK S 15	15	30.60	26.50
SSK S 25	25	43.70	39.80
SSK S 37	37	60.30	56.20

material: polyethylere

For female headers

art. no.	no. of contacts	dim. [mm]	
		A	B
SSK B 09	9	22.30	17.00
SSK B 15	15	30.60	25.00
SSK B 25	25	44.10	38.65
SSK B 37	37	60.70	55.30

material: polyethylere

A

B

C

D

E

F

G

H

I

K

L

M

N

A

B

C

D

E

F

G

H

I

K

L

M

N

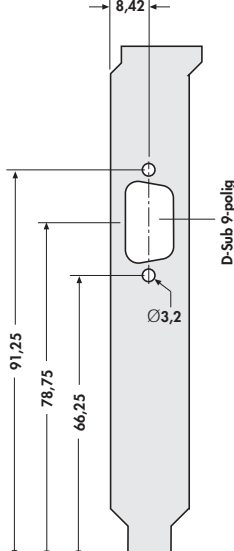
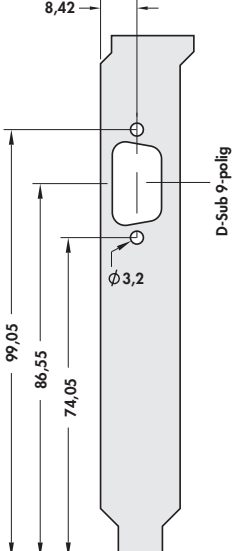
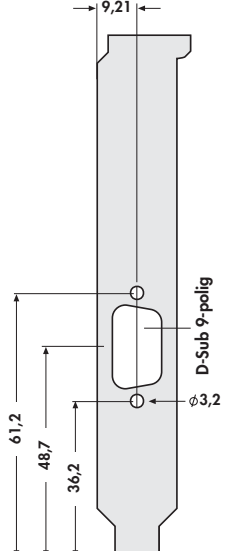
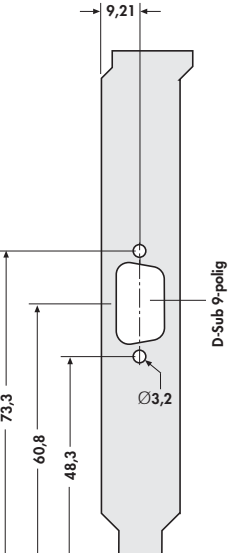
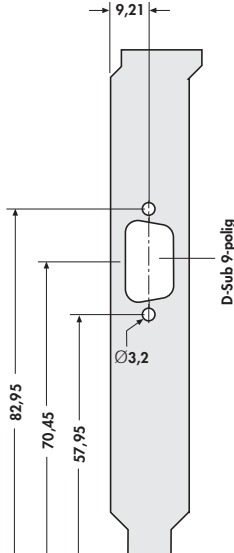
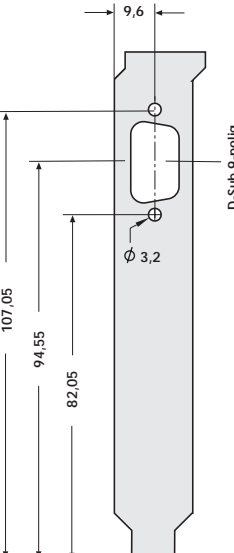
 <p>9</p>	<p>PCI 006 ...</p> 	<p>PCI 007 ...</p> 	<p>PCI 055 ...</p> 
<p>PCI 004 ...</p> 	<p>PCI 005 ...</p> 	<p>PCI 029 L</p> 	

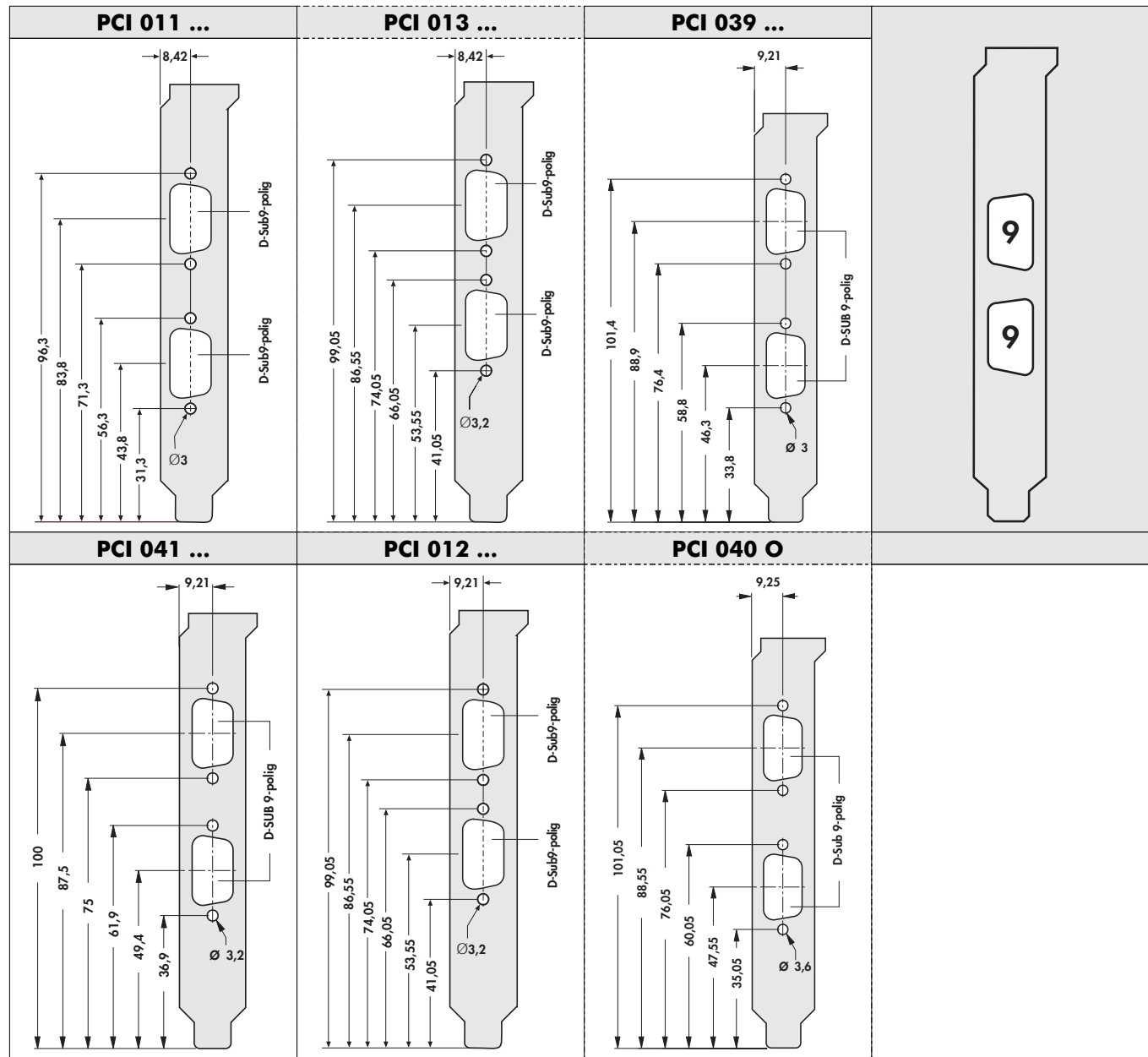

A

B

C

D

E

F

G

H

I

K

L

M

N

please indicate: ... fixing tab
L = bracket with fixing tab
O = bracket without fixing tab

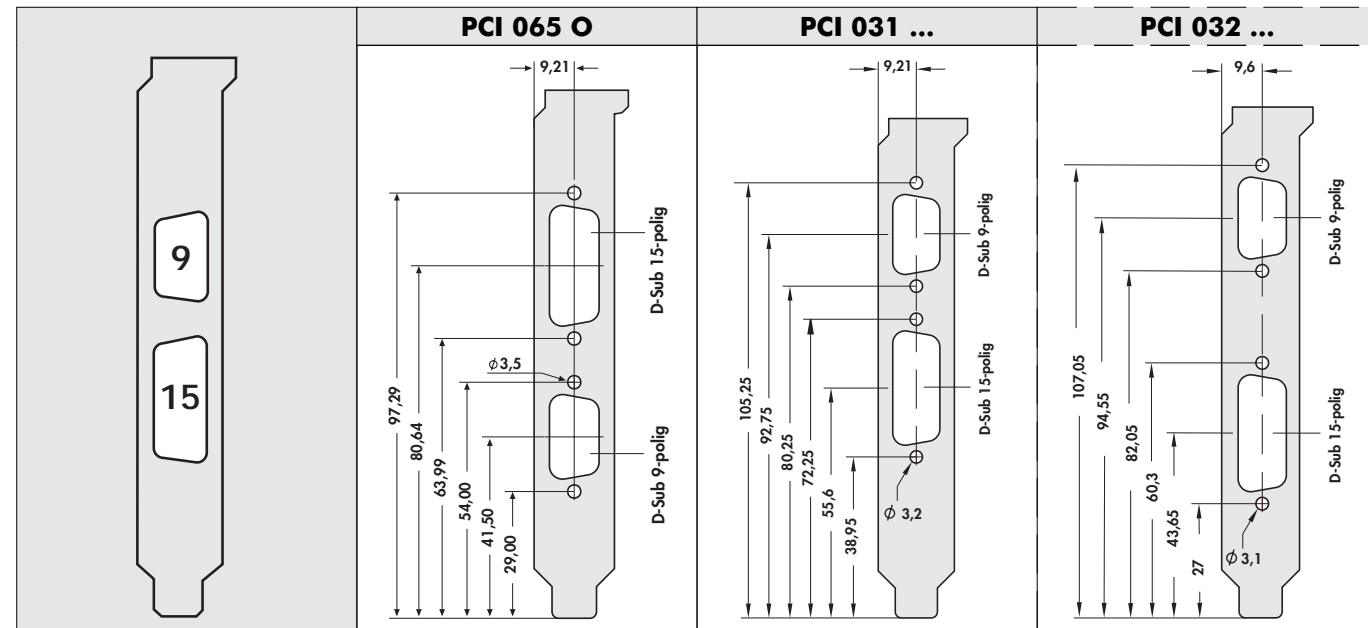

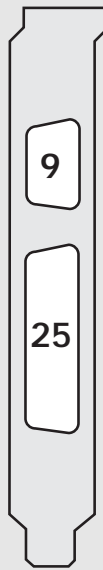
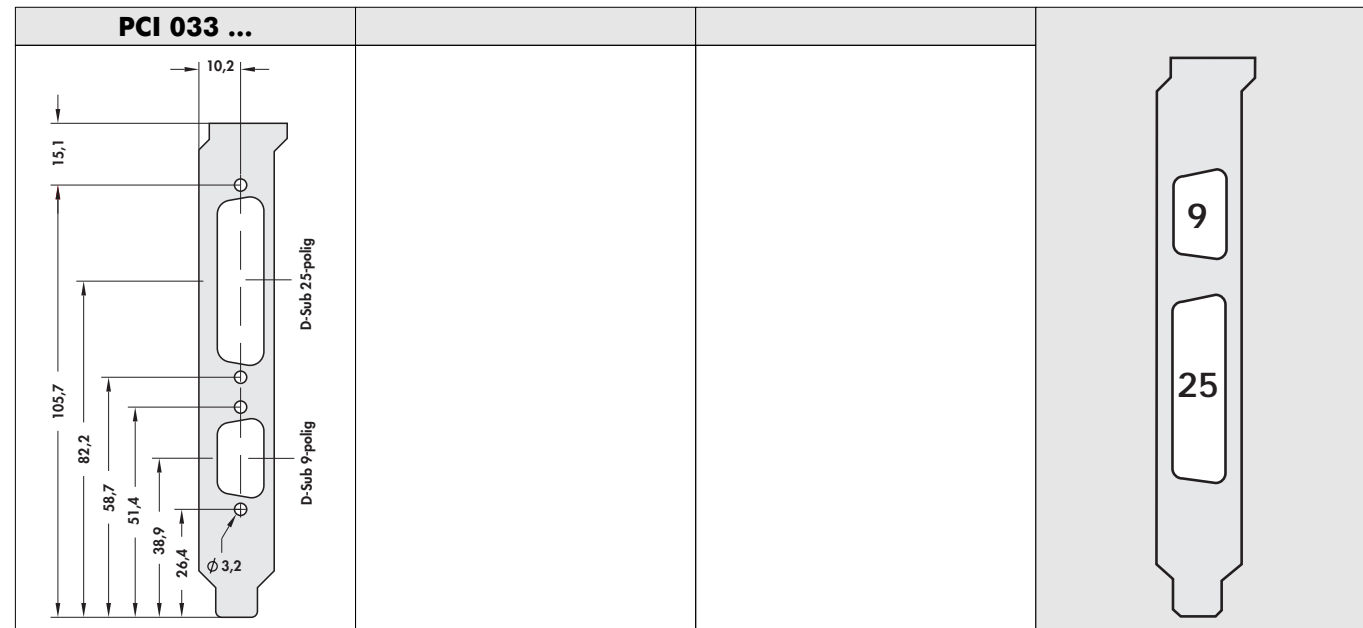

A

B

C

D

E

F

G

H

I

K

L

M

N

please indicate: ... fixing tab
L = bracket with fixing tab
O = bracket without fixing tab

K 10

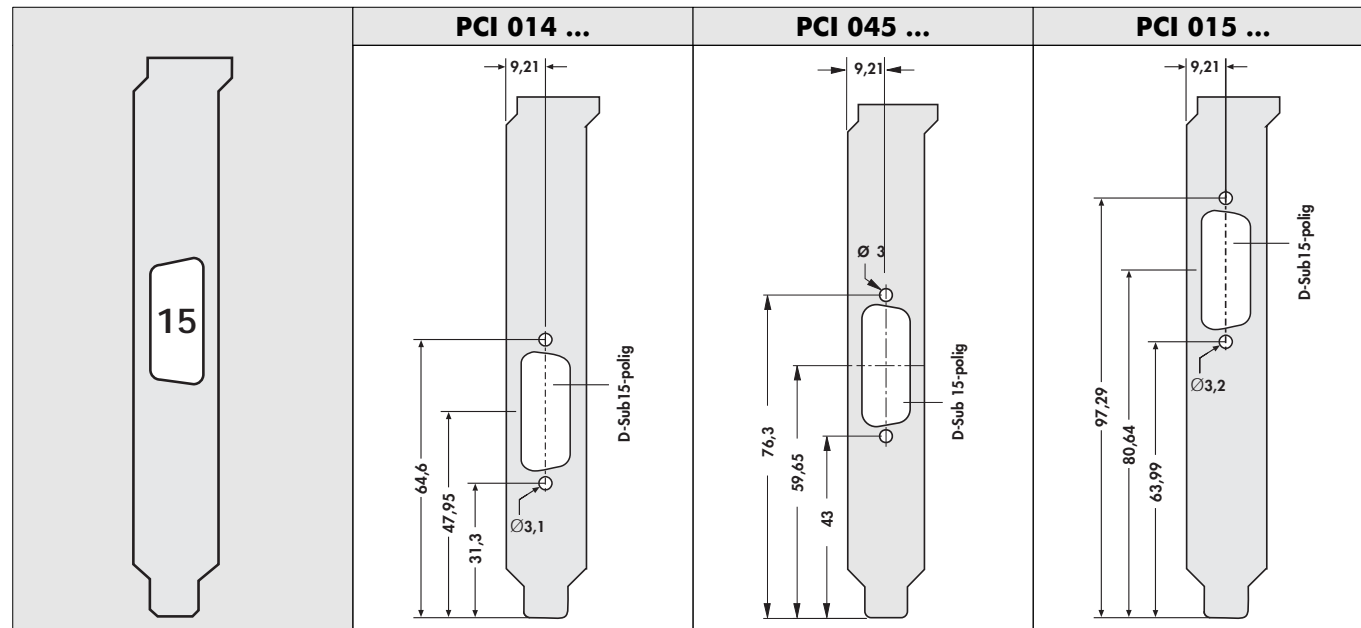

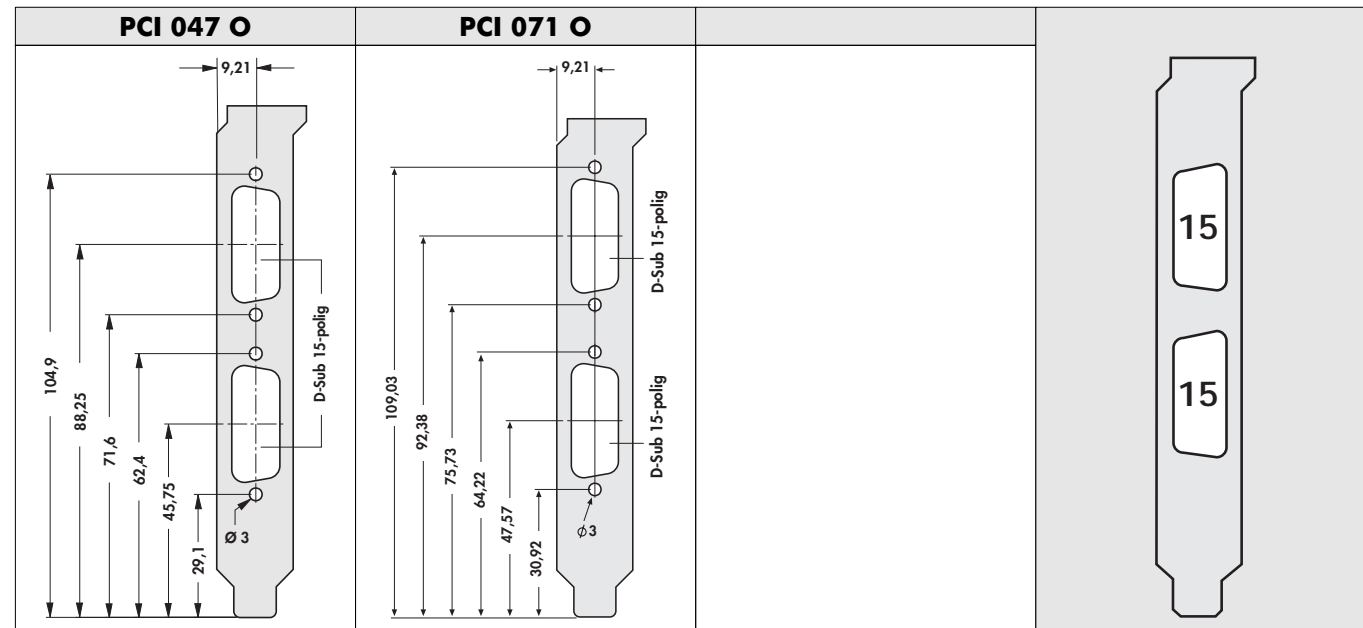

A

B

C

D

E

F

G

H

I

K

L

M

N

please indicate: ... fixing tab
L = bracket with fixing tab
O = bracket without fixing tab

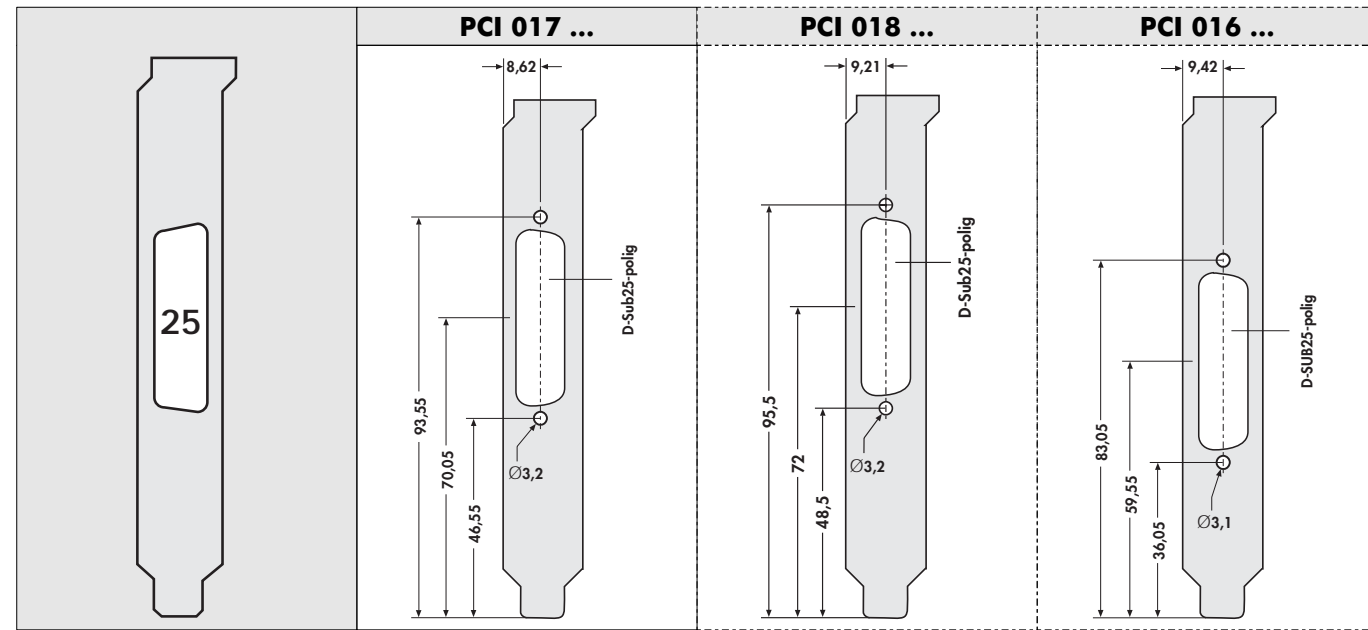

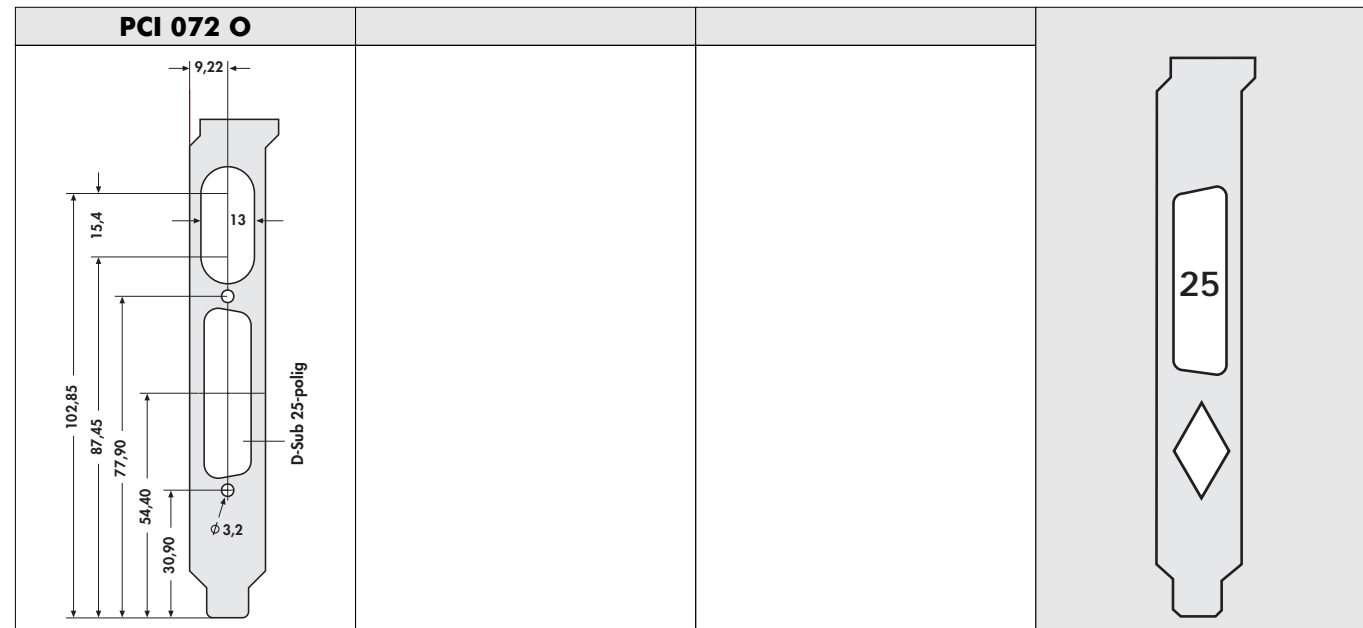

A

B

C

D

E

F

G

H

I

K

L

M

please indicate: ... fixing tab
 L = bracket with fixing tab
 O = bracket without fixing tab

K 14

N

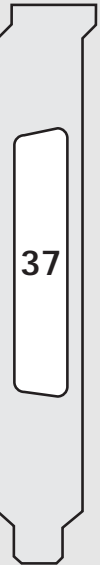
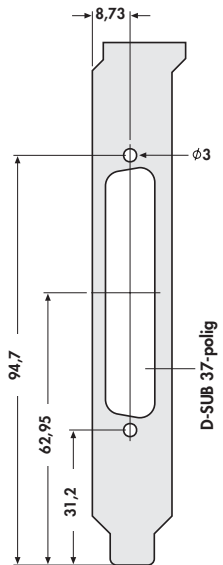
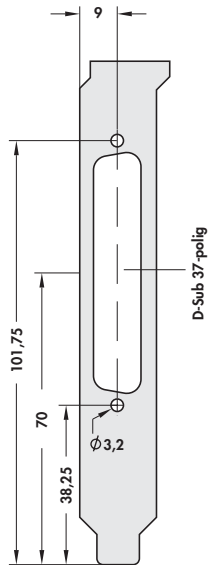
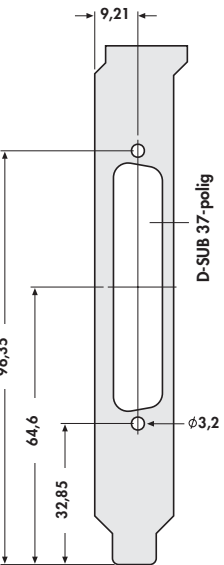
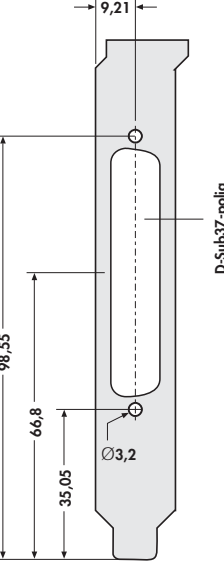
 <p>37</p>	<p>PCI 076 O</p>  <p>8,73 94,7 62,95 31,2 ∅3 D-SUB 37-polig</p>	<p>PCI 035 ...</p>  <p>9 101,75 70 38,25 ∅3,2 D-Sub 37-polig</p>	<p>PCI 077 ...</p>  <p>9,21 96,35 64,6 32,85 ∅3,2 D-SUB 37-polig</p>
<p>PCI 020 ...</p>  <p>9,21 98,55 66,8 35,05 ∅3,2 D-Sub37-polig</p>			

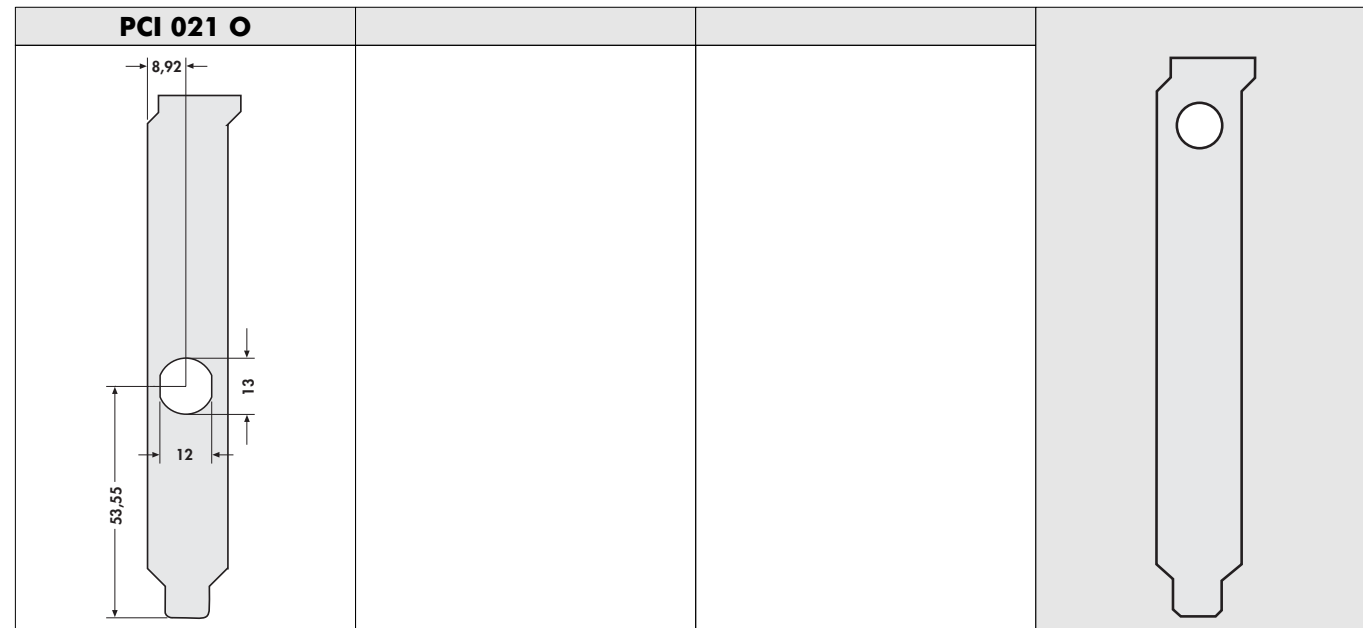

A

B

C

D

E

F

G

H

I

K

L

M

N

please indicate: ... fixing tab
 L = bracket with fixing tab
 O = bracket without fixing tab

K 16

A

B

C

D

E

F

G

H

I

K

L

M

N

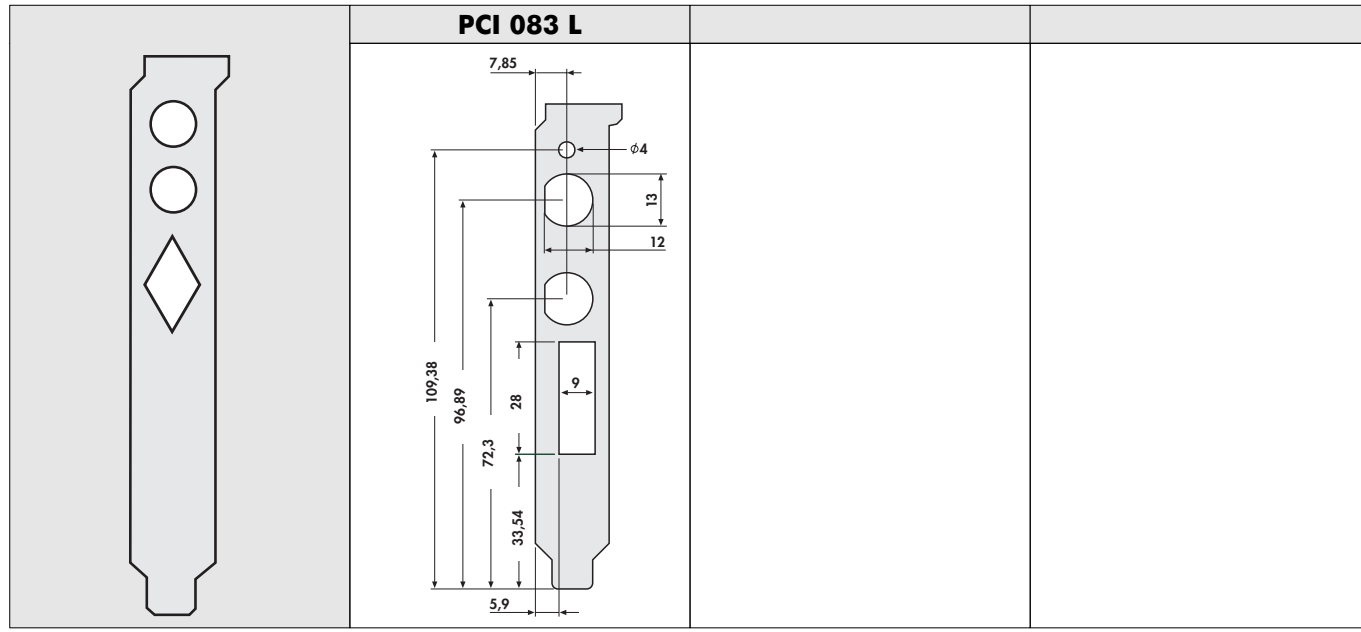

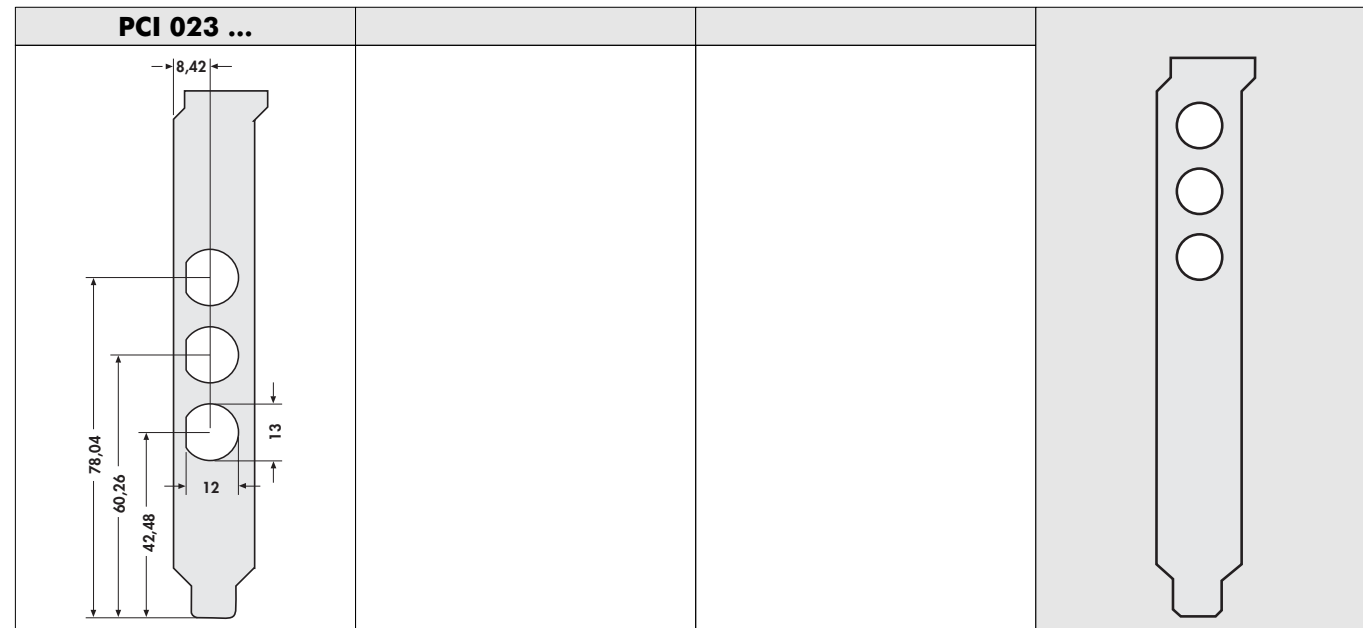

A

B

C

D

E

F

G

H

I

K

L

M

N

please indicate: ... fixing tab
 L = bracket with fixing tab
 O = bracket without fixing tab

K 18

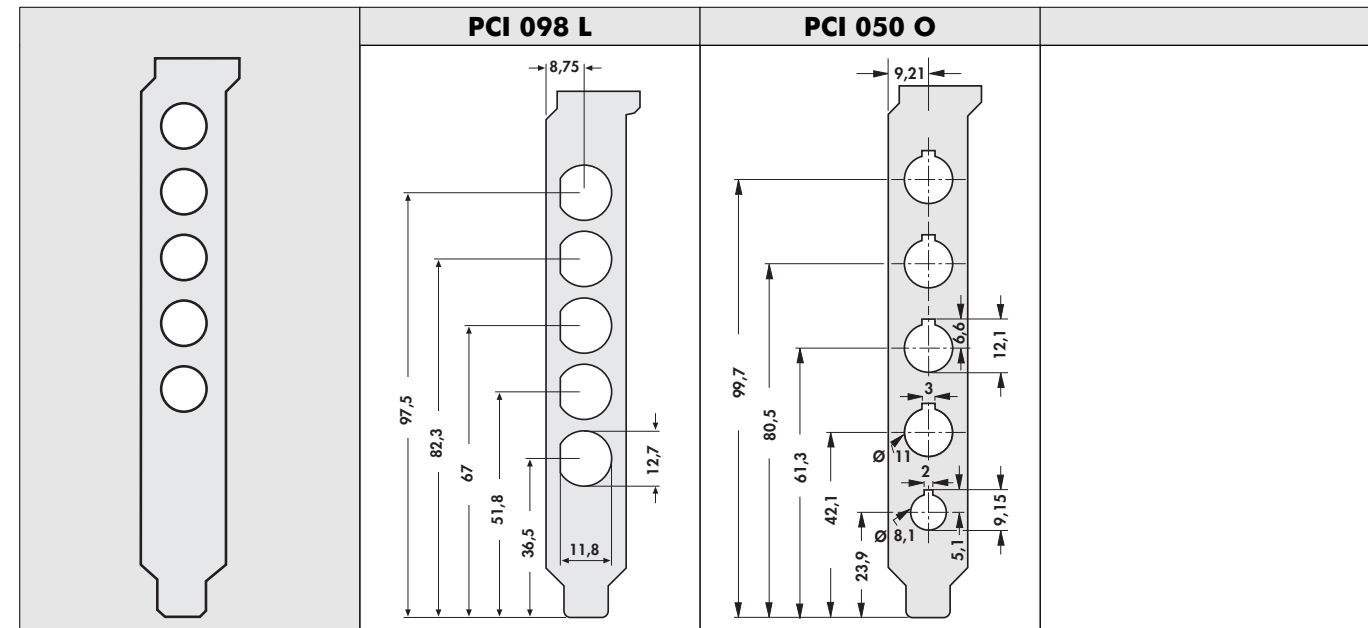

<p>PCI 027 L</p>	<p>PCI 105 L</p>	<p>PCI 104 O</p>	
<p>PCI 106 L</p>			

A

B

C

D

E

F

G

H

I

K

L

M

N

please indicate: ... fixing tab
 L = bracket with fixing tab
 O = bracket without fixing tab

A

B

C

D

E

F

G

H

I

K

L

M

N

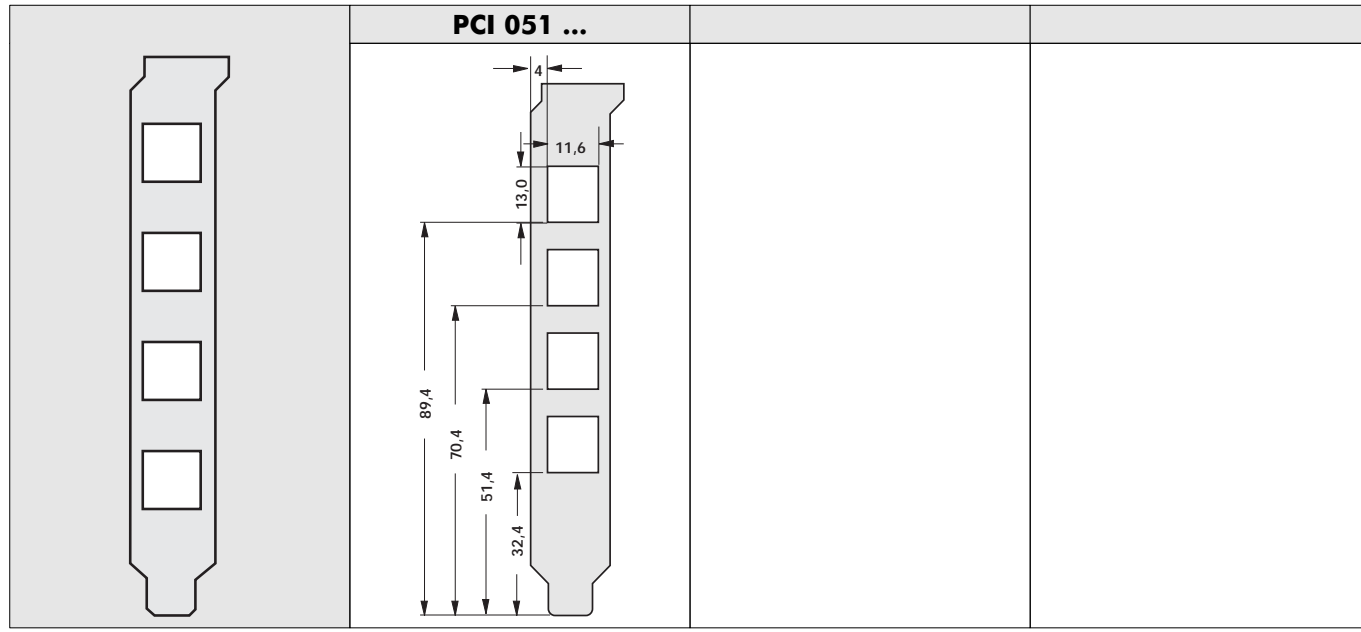

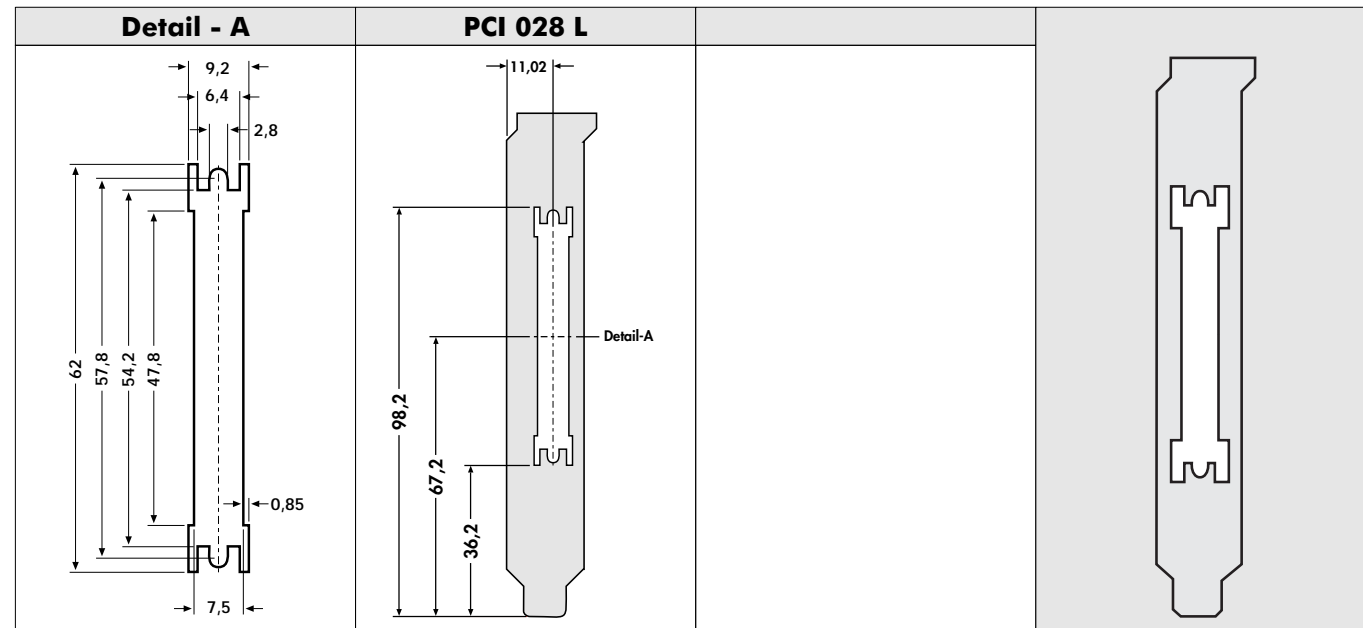

A

B

C

D

E

F

G

H

I

K

L

M

please indicate: ... fixing tab
 L = bracket with fixing tab
 O = bracket without fixing tab

K 22

N

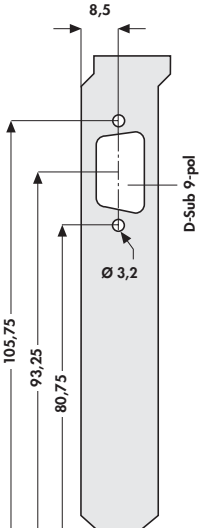
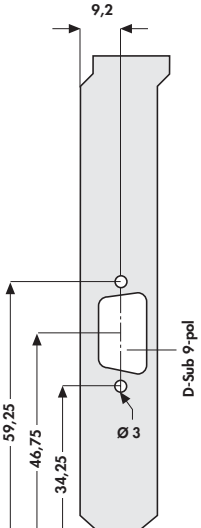
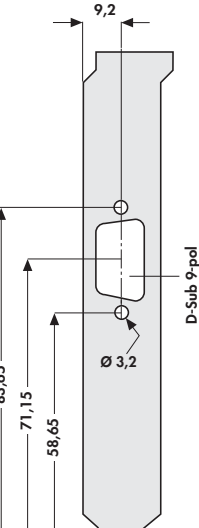
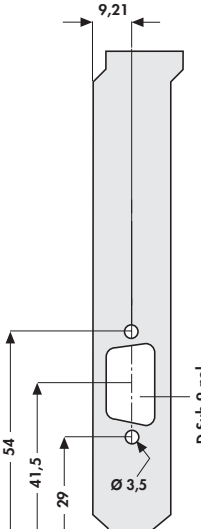
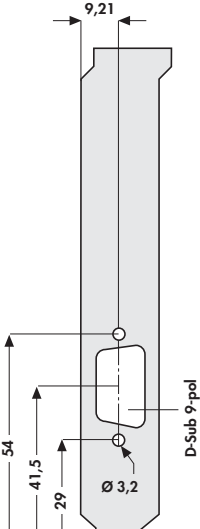
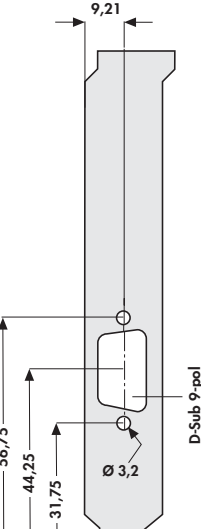
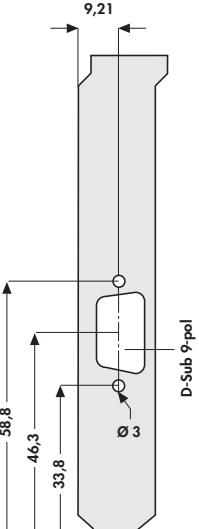
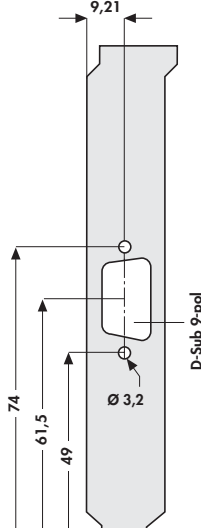
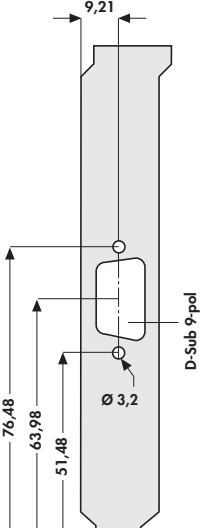
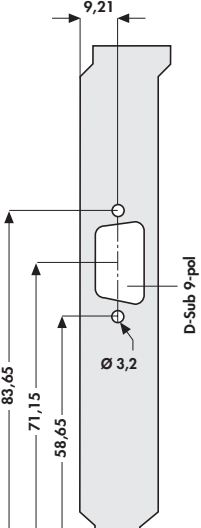
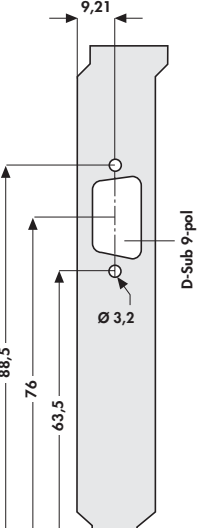
 <p>KHPC 007 O</p>	 <p>KHPC 002 O</p>	 <p>KHPC 092 ...</p>	 <p>KHPC 003 ...</p>
 <p>KHPC 010 ...</p>	 <p>KHPC 011 O</p>	 <p>KHPC 004 O</p>	 <p>KHPC 013 O</p>
 <p>KHPC 010 ...</p>	 <p>KHPC 093 L</p>	 <p>KHPC 094 O</p>	 <p>KHPC 096 O</p>

A

B

C

D

E

F

G

H

I

K

L

M

N

<p>KHPC 008 O</p>	<p>KHPC 014 O</p>	<p>KHPC 016 O</p>	
<p>KHPC 095 O</p>	<p>KHPC 017 ...</p>	<p>KHPC 102 O</p>	

please indicate: ... fixing tab
L = bracket with fixing tab
O = bracket without fixing tab

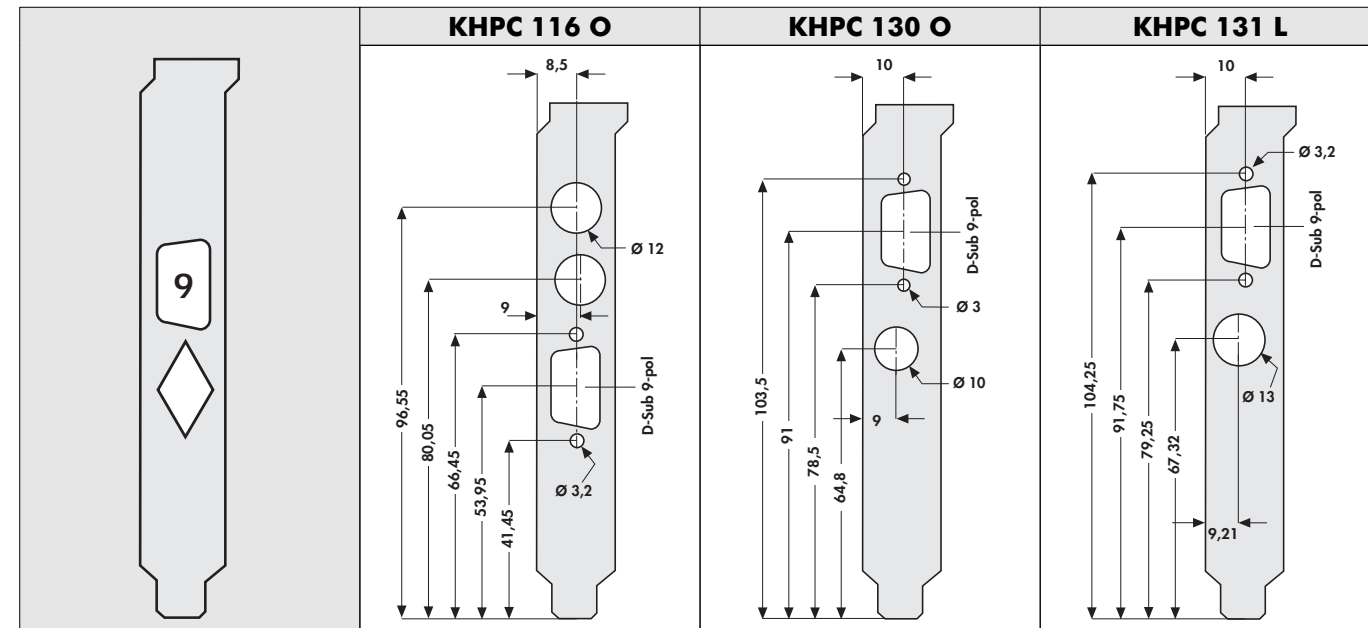

<p>KHPC 144 O</p>	<p>KHPC 142 O</p>	<p>KHPC 053 O</p>	
<p>KHPC 138 O</p>	<p>KHPC 006 O</p>	<p>KHPC 141 O</p>	<p>KHPC 012 O</p>
<p>KHPC 072 O</p>	<p>KHPC 150 O</p>	<p>KHPC 009 O</p>	<p>KHPC 143 O</p>

A

B

C

D

E

F

G

H

I

K

L

M

N

please indicate: ... fixing tab
L = bracket with fixing tab
O = bracket without fixing tab

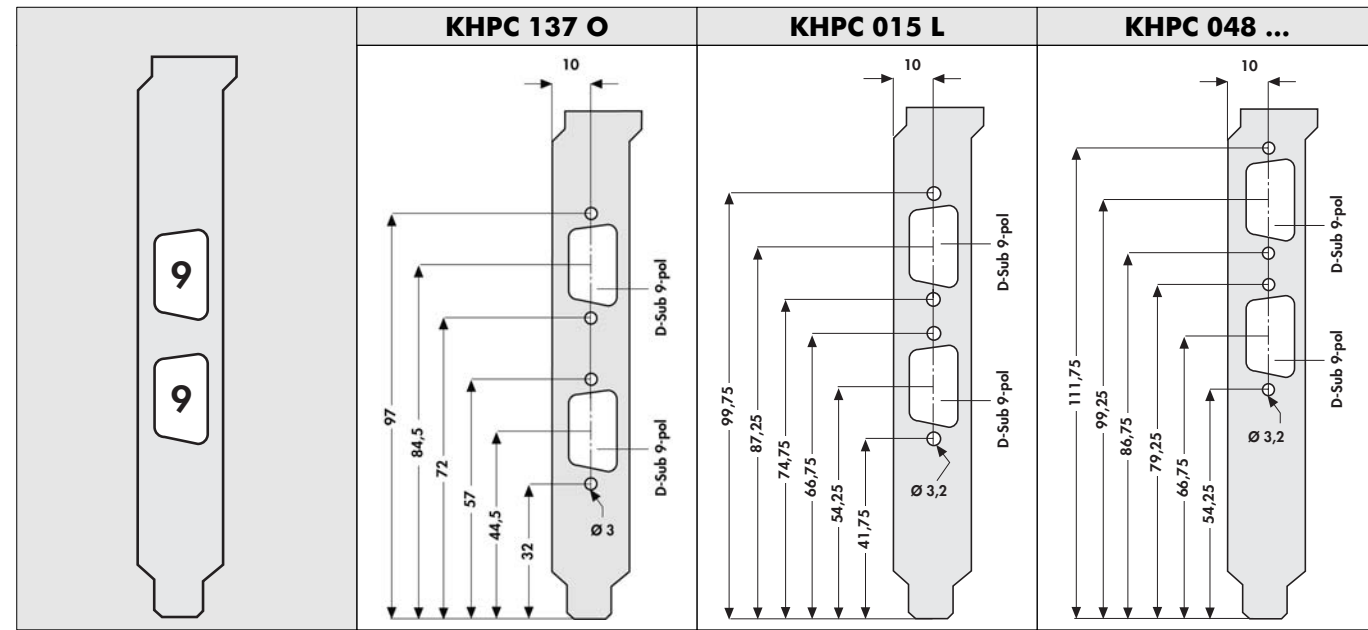

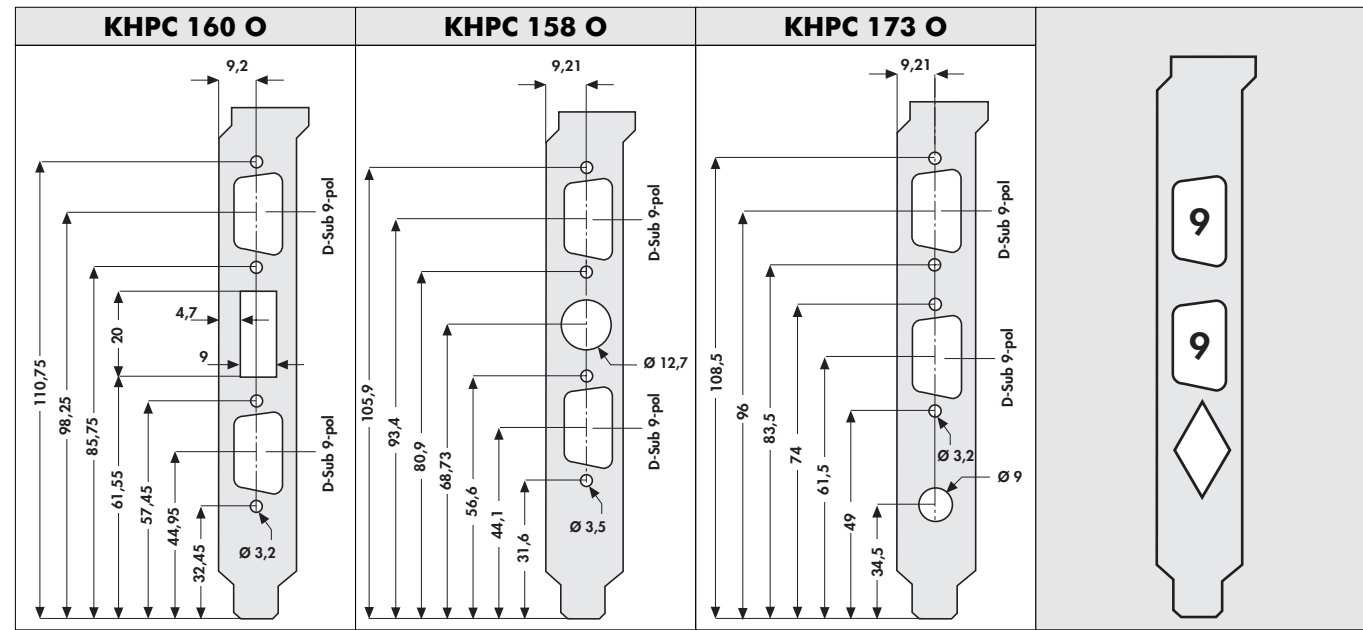

A

B

C

D

E

F

G

H

I

K

L

M

N

please indicate: ... fixing tab
L = bracket with fixing tab
O = bracket without fixing tab

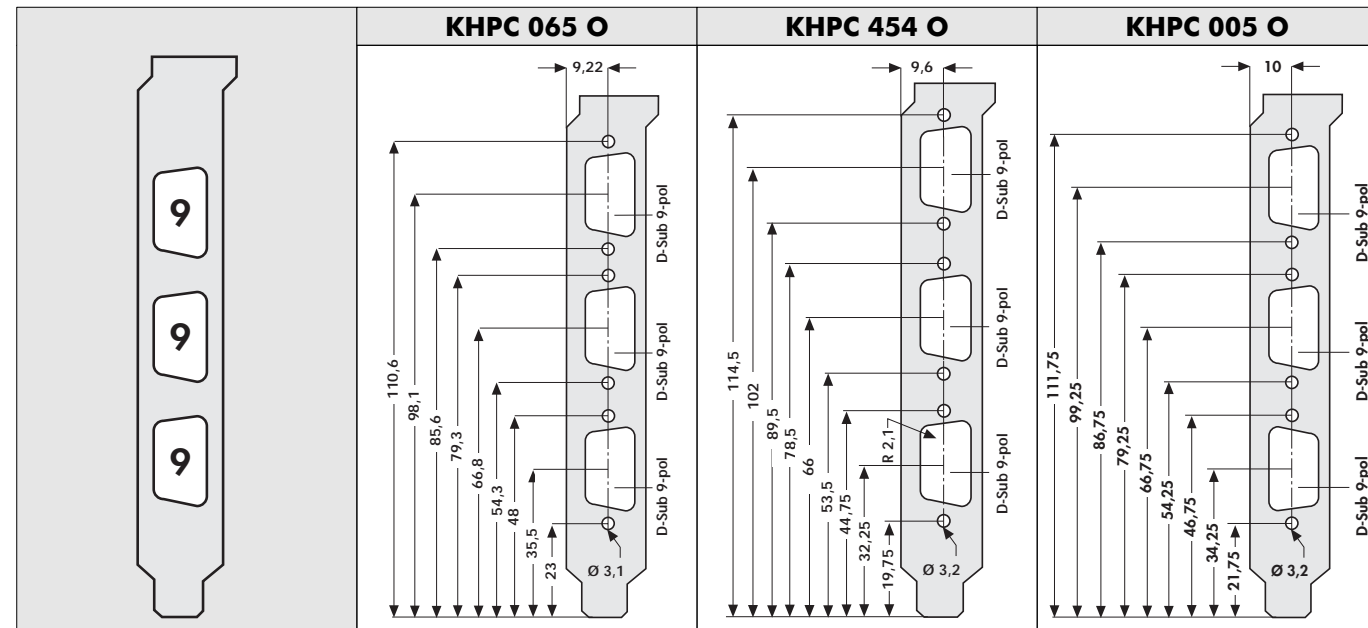

<p>KHPC 179 O</p>	<p>KHPC 177 ...</p>	<p>KHPC 178 O</p>	
<p>KHPC 076 O</p>			

A

B

C

D

E

F

G

H

I

K

L

M

N

please indicate: ... fixing tab
L = bracket with fixing tab
O = bracket without fixing tab

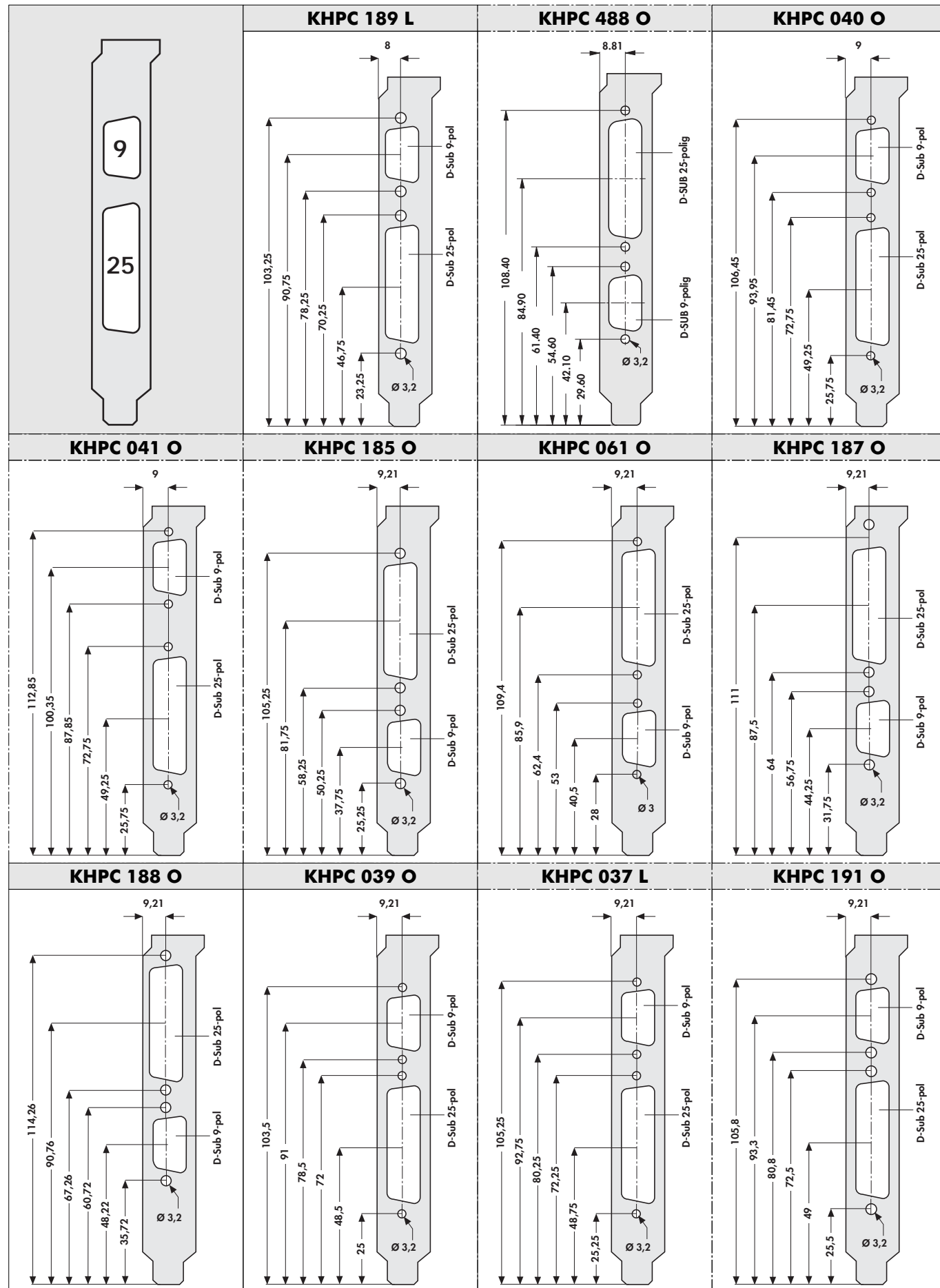

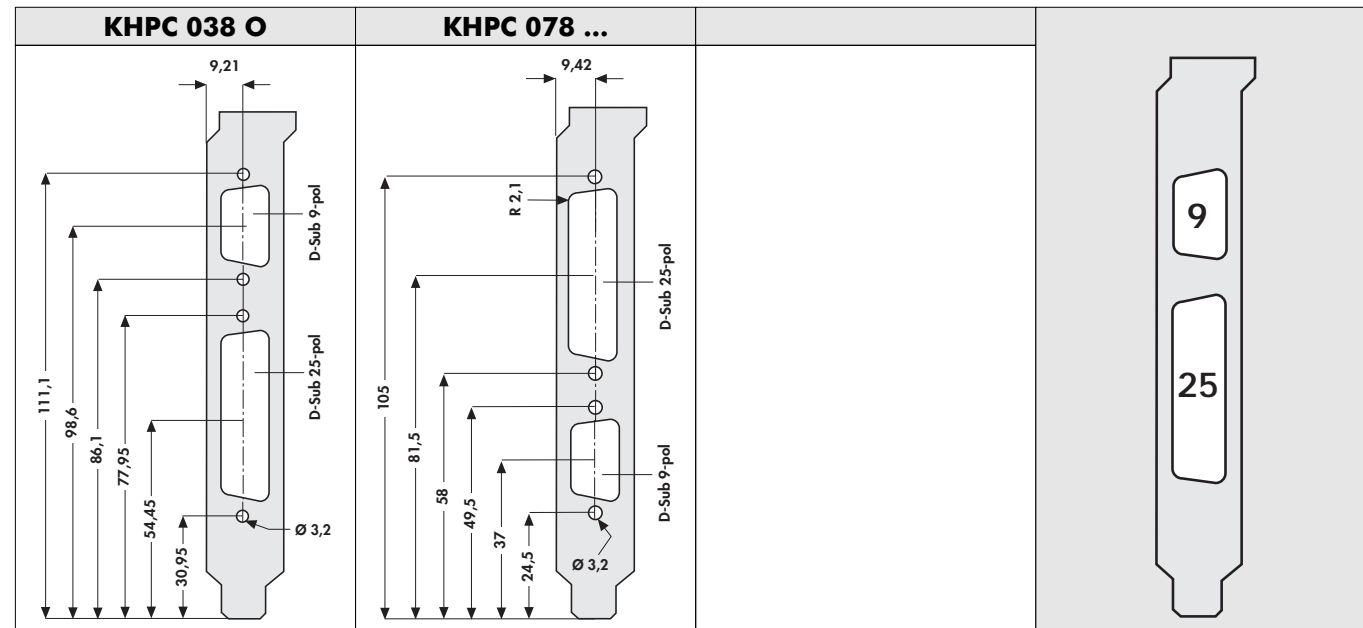

A

B

C

D

E

F

G

H

I

K

L

M

N

please indicate: ... fixing tab
 L = bracket with fixing tab
 O = bracket without fixing tab

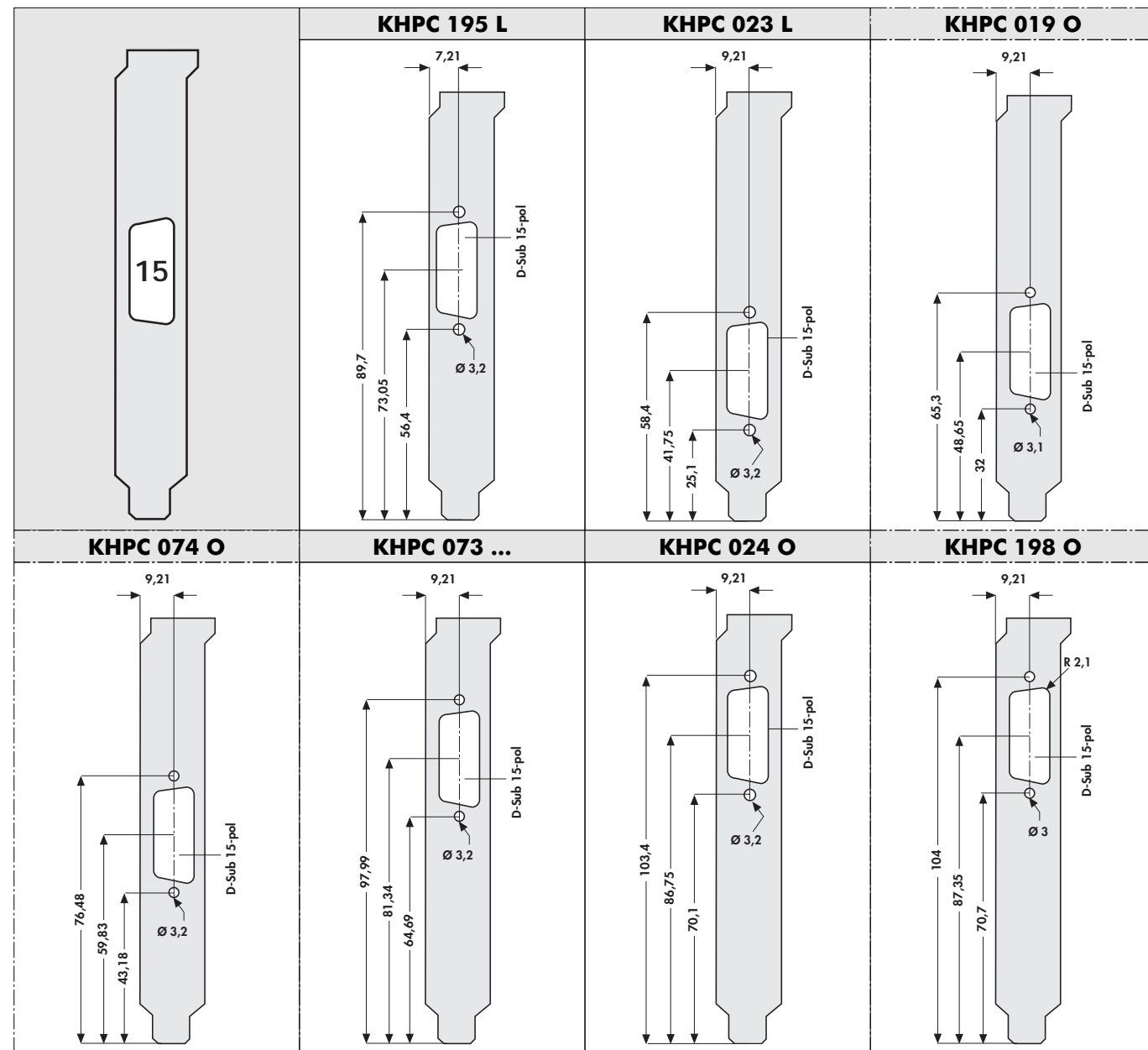

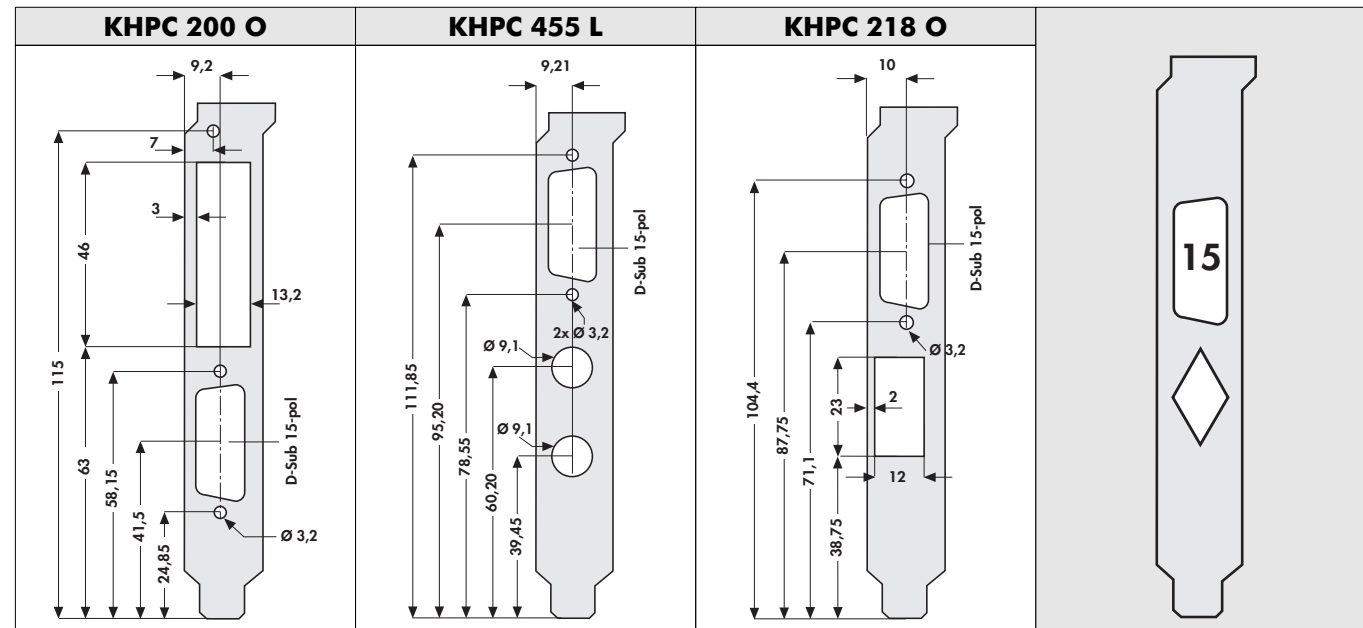

A

B

C

D

E

F

G

H

I

K

L

M

N

please indicate: ... fixing tab
 L = bracket with fixing tab
 O = bracket without fixing tab

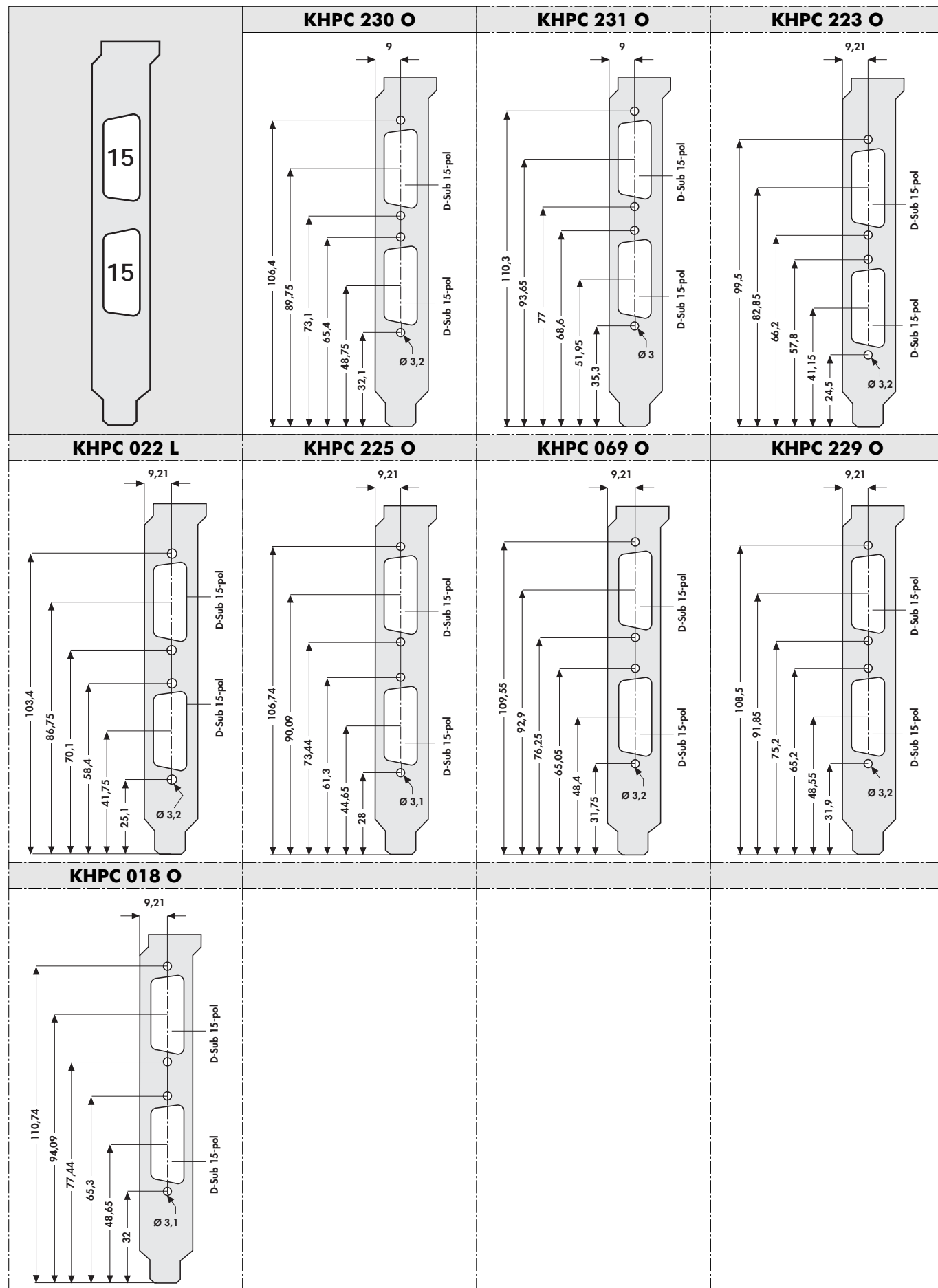

KHPC 241 O	KHPC 042 O	KHPC 242 O	
KHPC 075 O			

A

B

C

D

E

F

G

H

I

K

L

M

N

please indicate: ... fixing tab
L = bracket with fixing tab
O = bracket without fixing tab

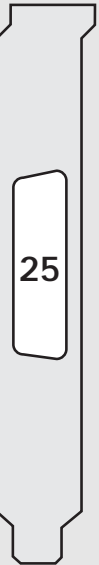
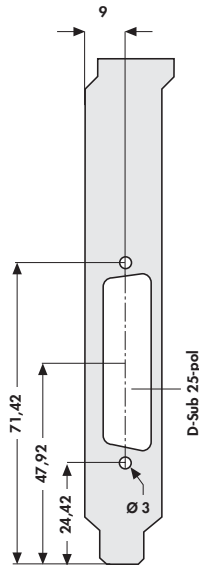
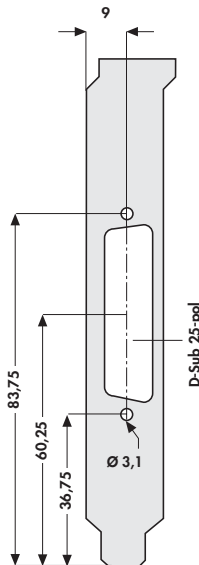
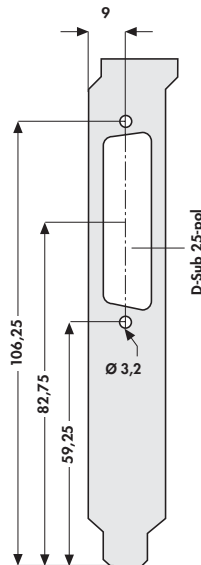
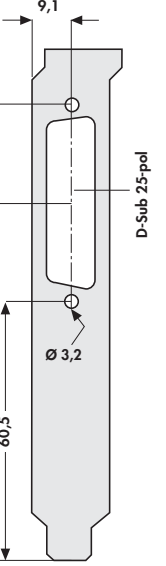
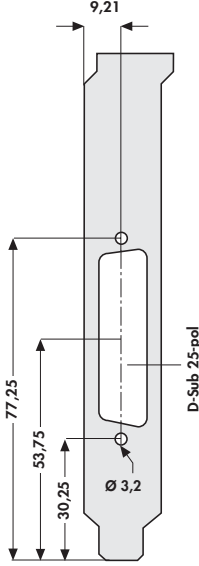
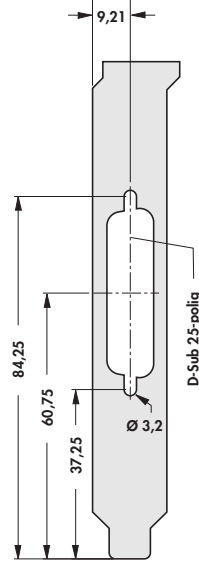
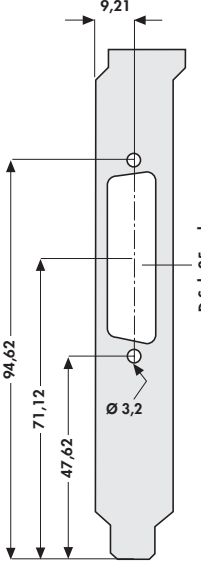
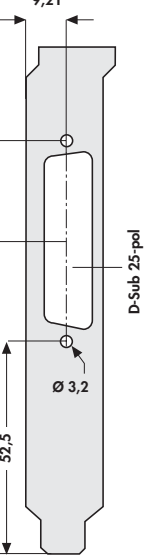
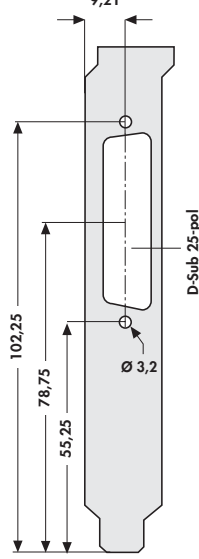
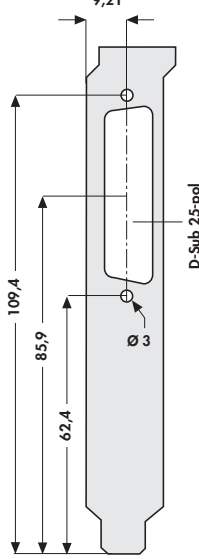
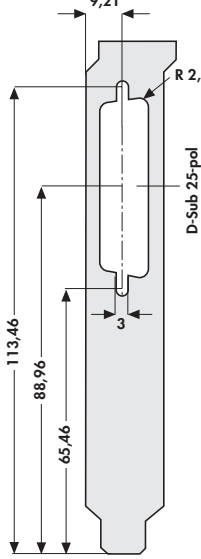
	<p>KHPC 243 O</p> 	<p>KHPC 070 O</p> 	<p>KHPC 027 O</p> 
<p>KHPC 054 O</p> 	<p>KHPC 028 O</p> 	<p>KHPC 491 O</p> 	<p>KHPC 026 ...</p> 
<p>KHPC 252 O</p> 	<p>KHPC 255 O</p> 	<p>KHPC 257 O</p> 	<p>KHPC 258 L</p> 

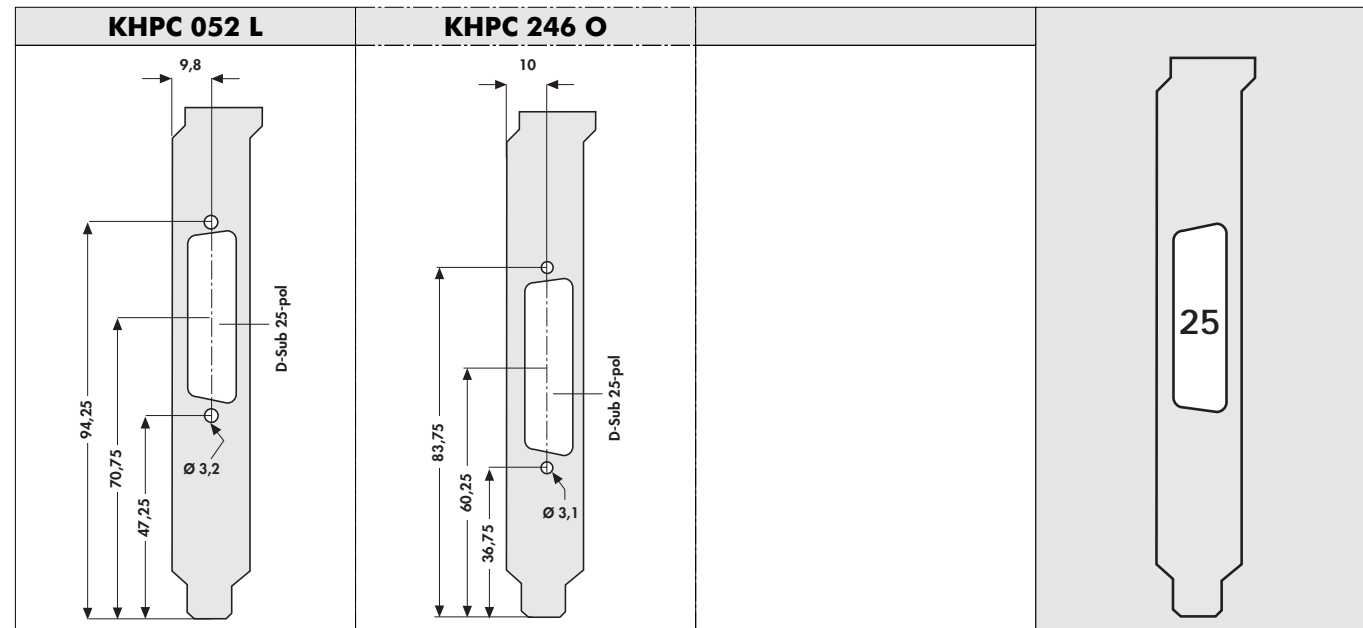

A

B

C

D

E

F

G

H

I

K

L

M

N

please indicate: ... fixing tab
 L = bracket with fixing tab
 O = bracket without fixing tab

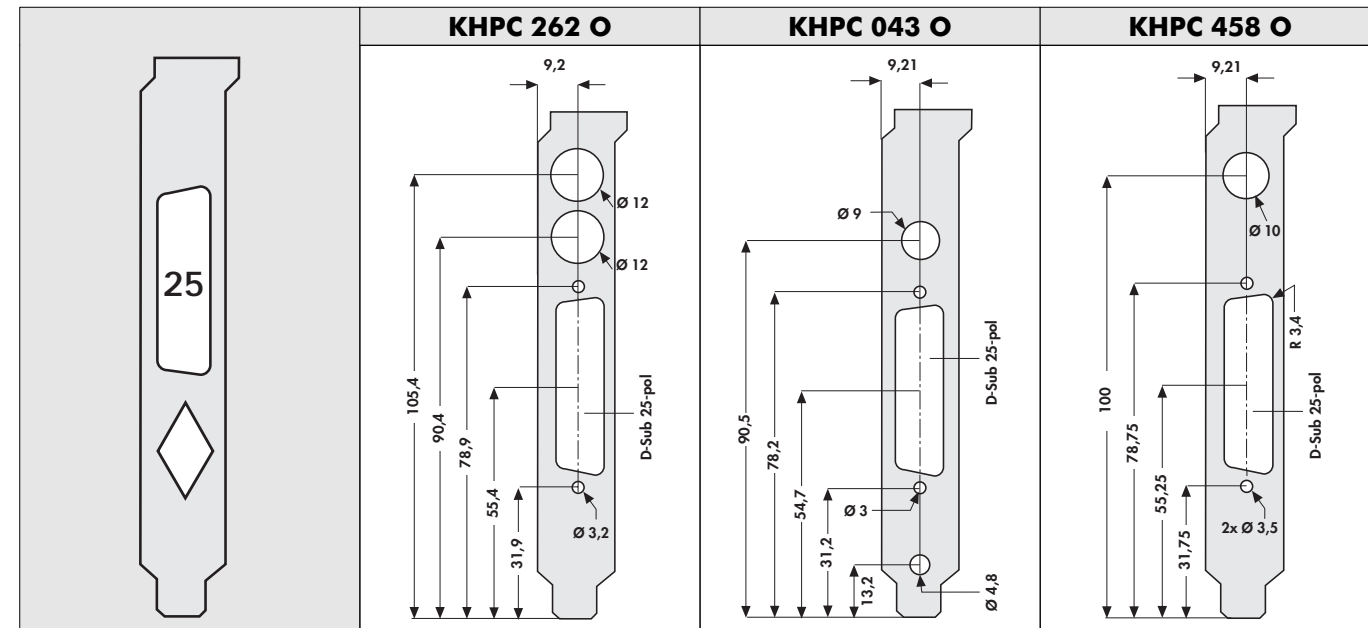

<p>KHPC 058 O</p>	<p>KHPC 035 O</p>	<p>KHPC 277 O</p>	<p>37</p>
<p>KHPC 267 ...</p>	<p>KHPC 033 O</p>	<p>KHPC 269 O</p>	<p>KHPC 270 O</p>
<p>KHPC 271 O</p>	<p>KHPC 274 O</p>	<p>KHPC 278 O</p>	<p>KHPC 034 O</p>

please indicate: ... fixing tab
L = bracket with fixing tab
O = bracket without fixing tab

A

B

C

D

E

F

G

H

I

K

L

M

N

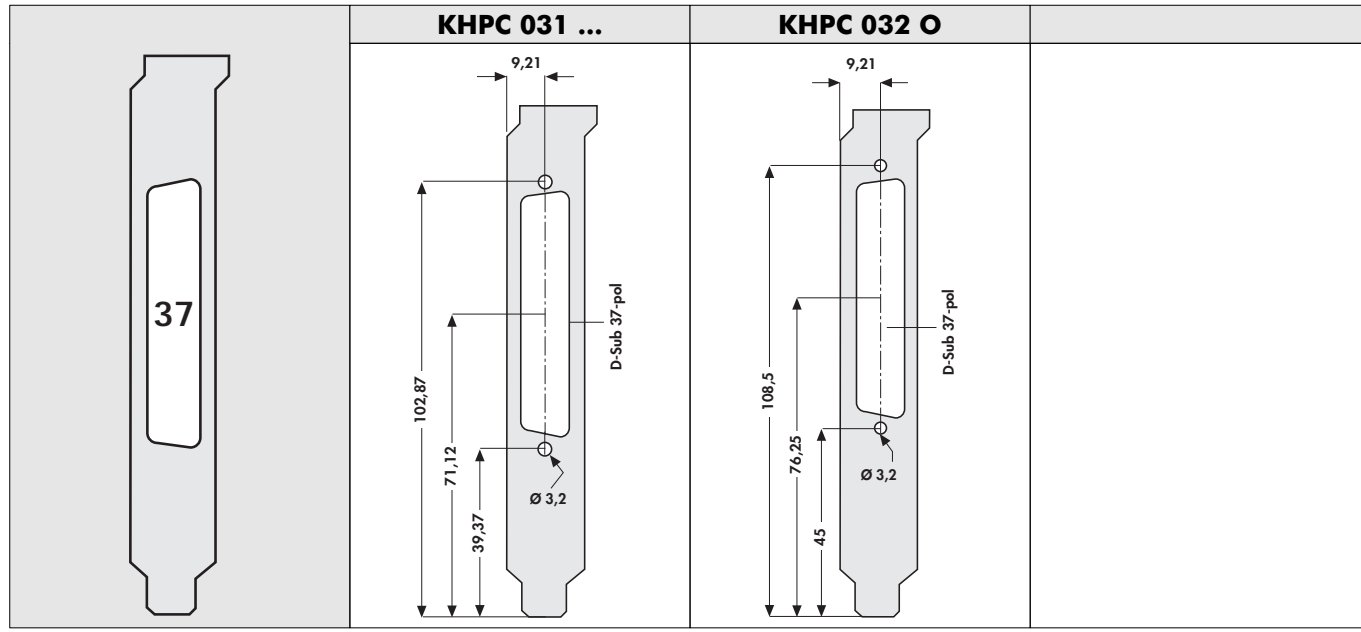

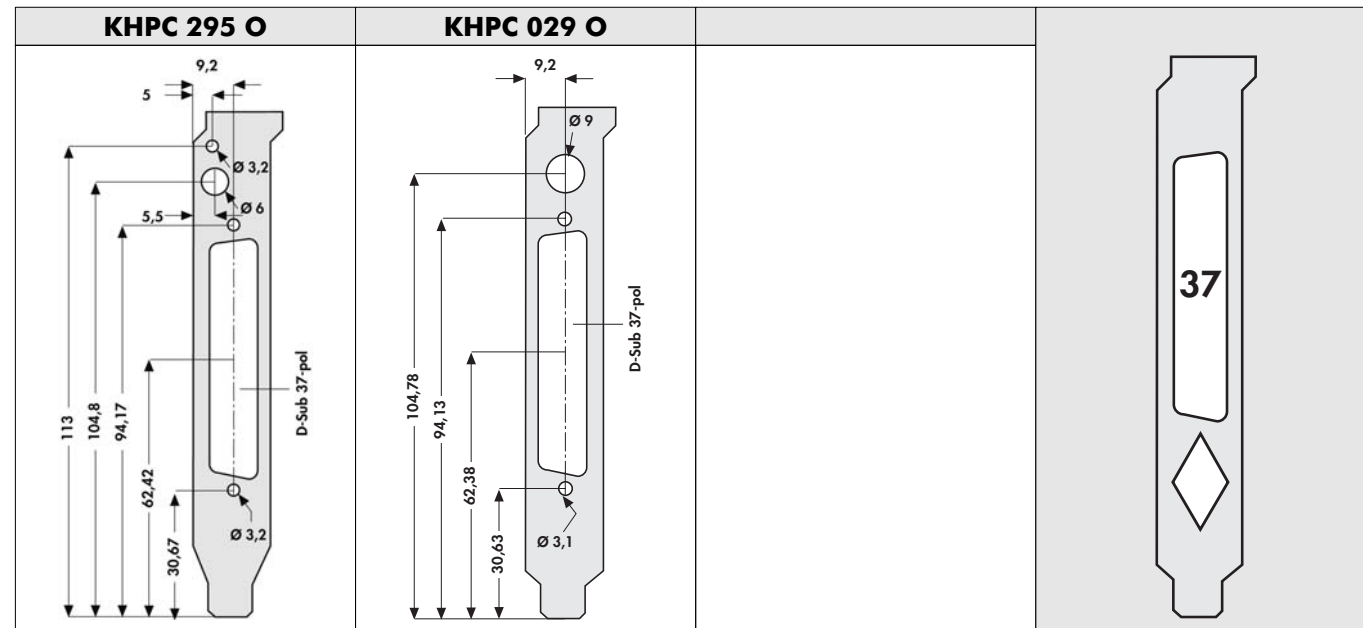

A

B

C

D

E

F

G

H

I

K

L

M

N

please indicate: ... fixing tab
 L = bracket with fixing tab
 O = bracket without fixing tab

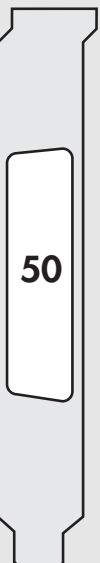
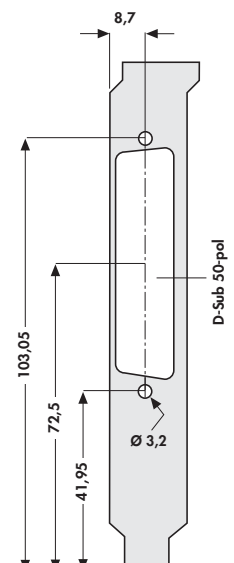
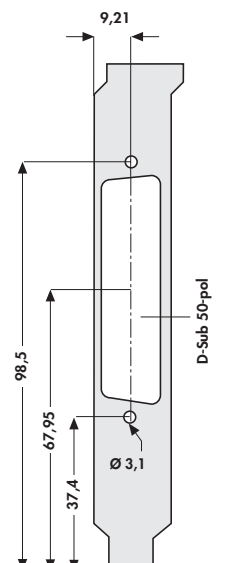
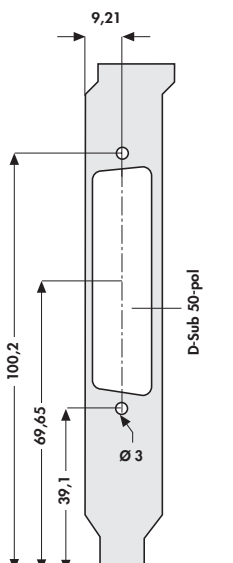
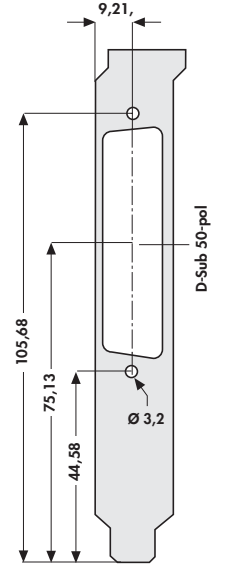
	KHPC 036 ...	KHPC 051 O	KHPC 083 O
			
KHPC 308 L			
			

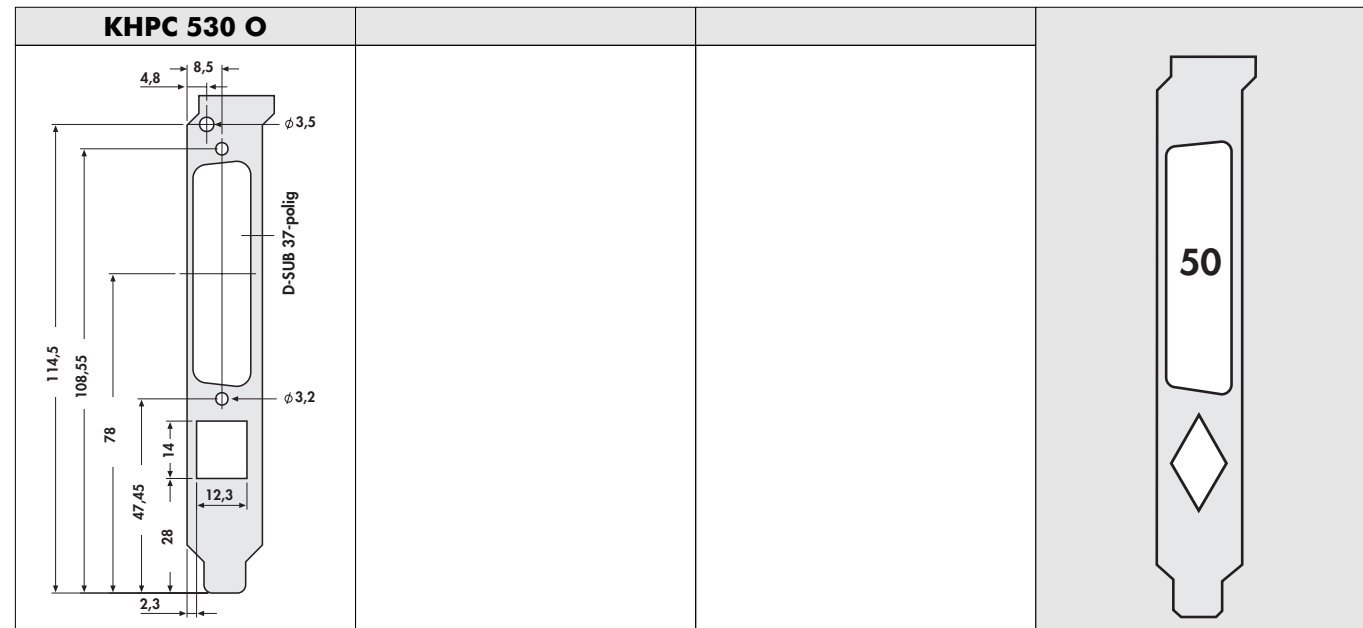

A

B

C

D

E

F

G

H

I

K

L

M

please indicate: ... fixing tab
L = bracket with fixing tab
O = bracket without fixing tab

K 44

N

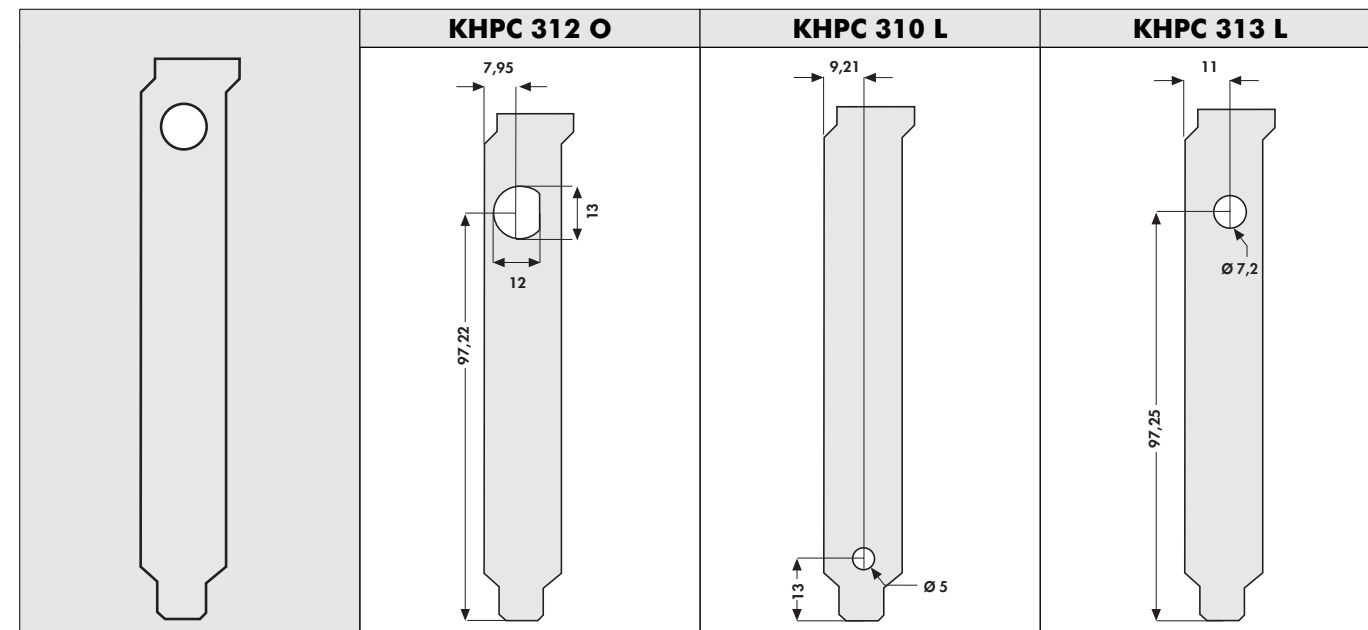

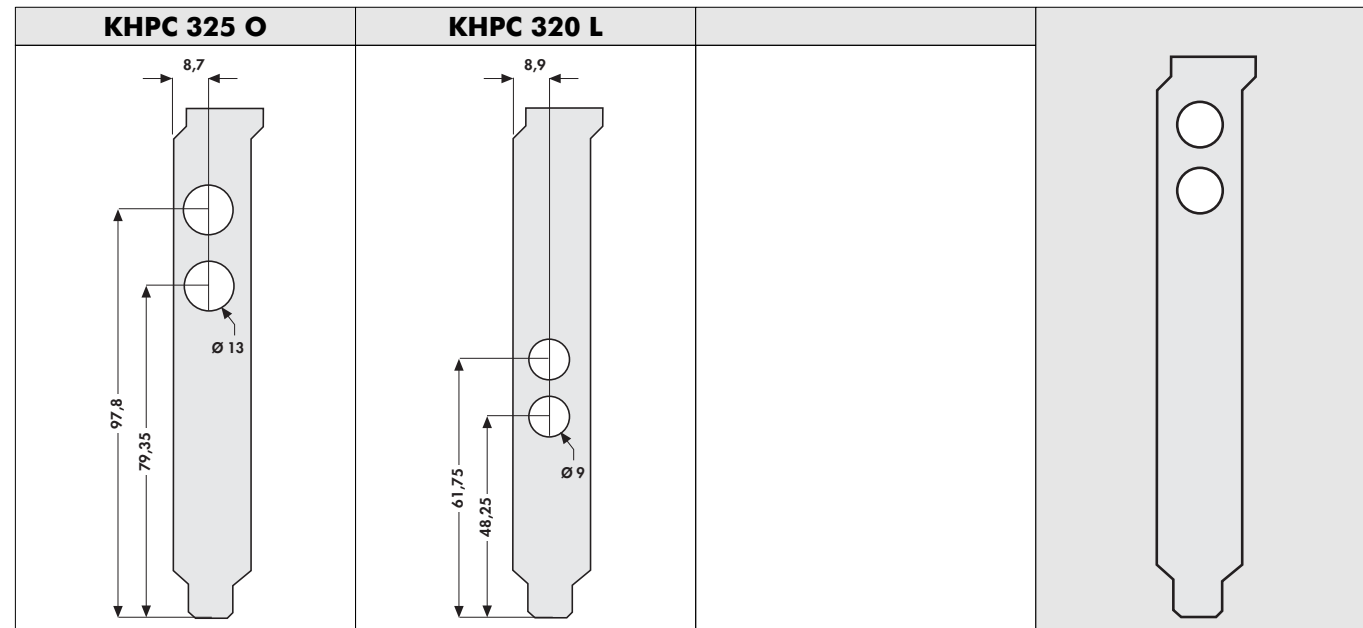

A

B

C

D

E

F

G

H

I

K

L

M

N

please indicate: ... fixing tab
 L = bracket with fixing tab
 O = bracket without fixing tab

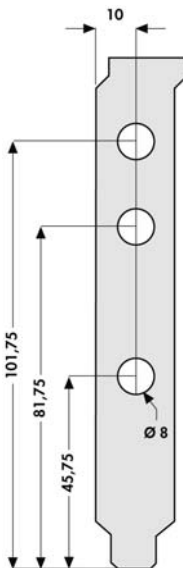
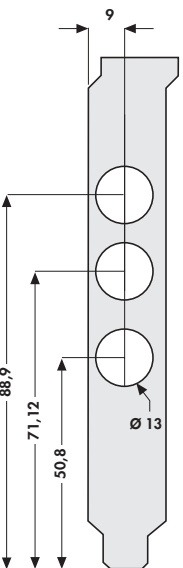
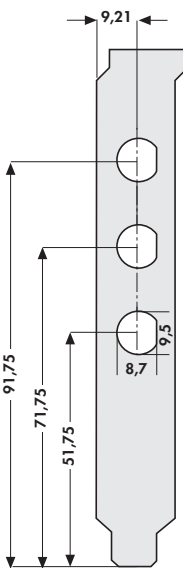
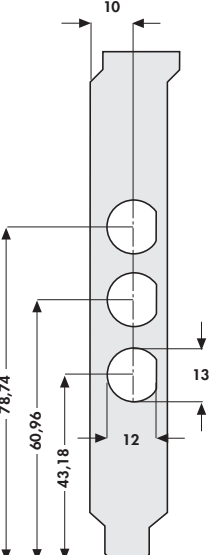
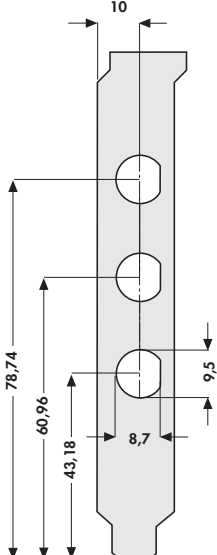
	<p>KHPC 333 L</p> 	<p>KHPC 335 L</p> 	<p>KHPC 463 O</p> 
<p>KHPC 044 L</p>	<p>KHPC 332 L</p>		
			

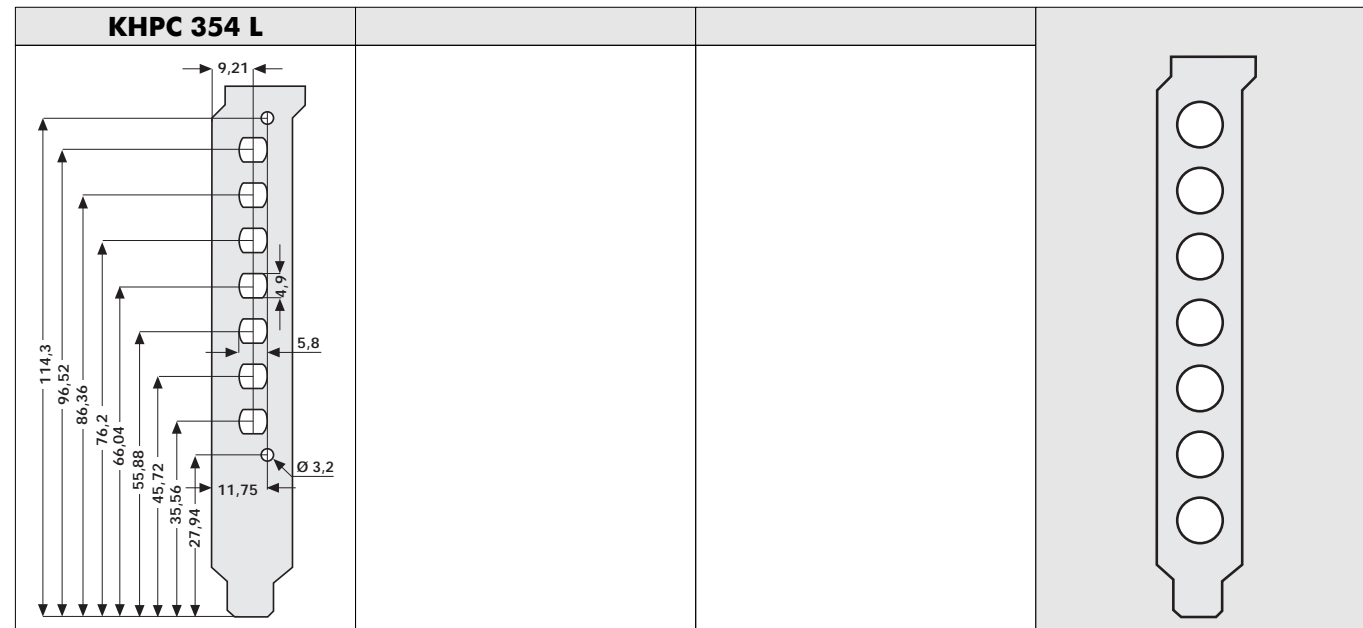

A

B

C

D

E

F

G

H

I

K



L

M

please indicate: ... fixing tab
L = bracket with fixing tab
O = bracket without fixing tab

K 48

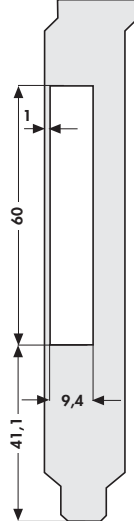
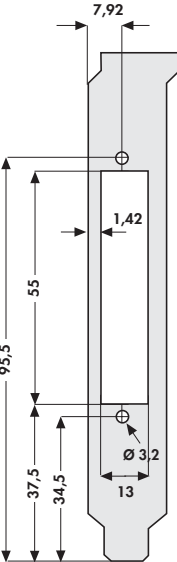
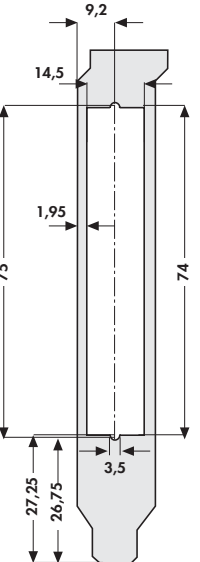
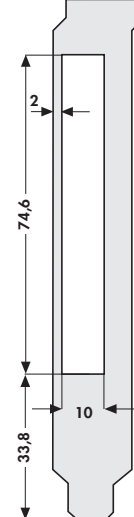
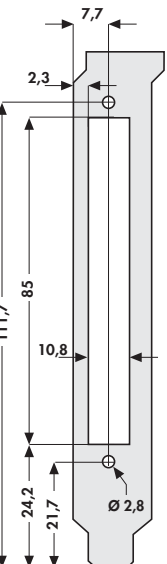
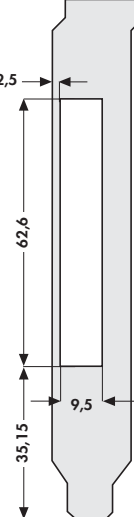
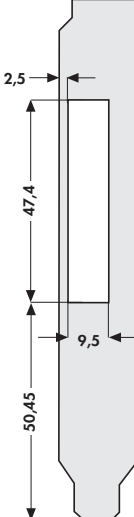
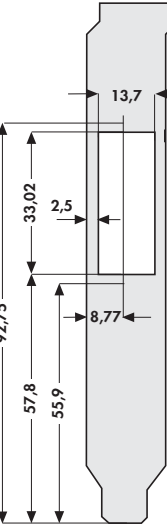
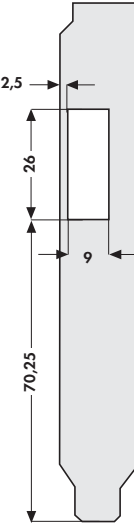
N

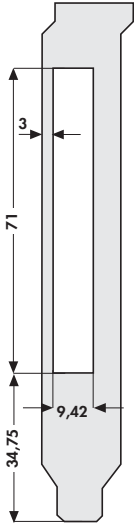
	<p>KHPC 055 L</p> 	<p>KHPC 377 L</p> 	<p>KHPC 389 O</p> 
<p>KHPC 390 L</p>	<p>KHPC 394 ...</p>	<p>KHPC 380 L</p>	<p>KHPC 371 L</p>
	<p>KHPC 365 L</p> 	<p>KHPC 085 L</p> 	<p>KHPC 384 L</p> 
<p>KHPC 367 L</p>	<p>KHPC 365 L</p>	<p>KHPC 085 L</p>	<p>KHPC 384 L</p>
	<p>KHPC 49 L</p> 		

A

B

C

D

E

F

G

H

I

K

L

M

N

<p>KHPC 062 L</p>	<p>KHPC 059 L</p>	<p>KHPC 398 ...</p>	
<p>KHPC 399 L</p>	<p>KHPC 391 O</p>	<p>KHPC 086 O</p>	<p>KHPC 366 O</p>

please indicate: ... fixing tab
L = bracket with fixing tab
O = bracket without fixing tab

A

B

C

D

E

F

G

H

I

K

L

M

N

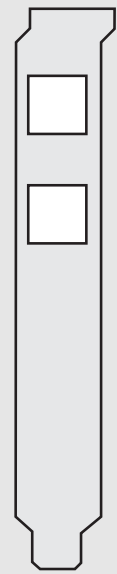
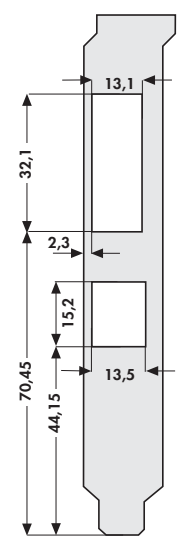
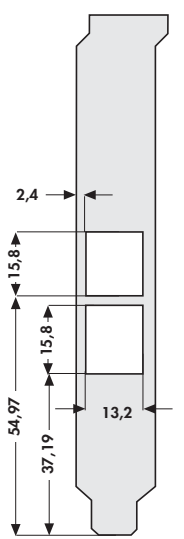
	KHPC 404 L	KHPC 407 L	
			

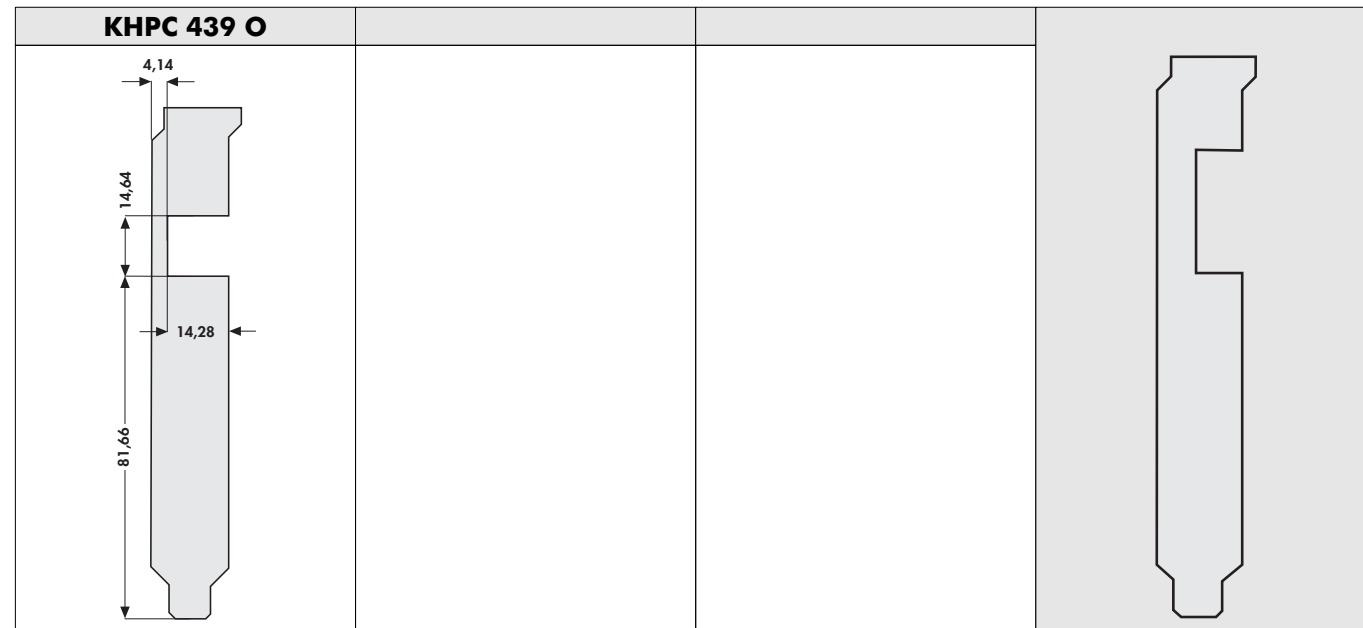

A

B

C

D

E

F

G

H

I

K

L

M



N

please indicate: ... fixing tab
 L = bracket with fixing tab
 O = bracket without fixing tab

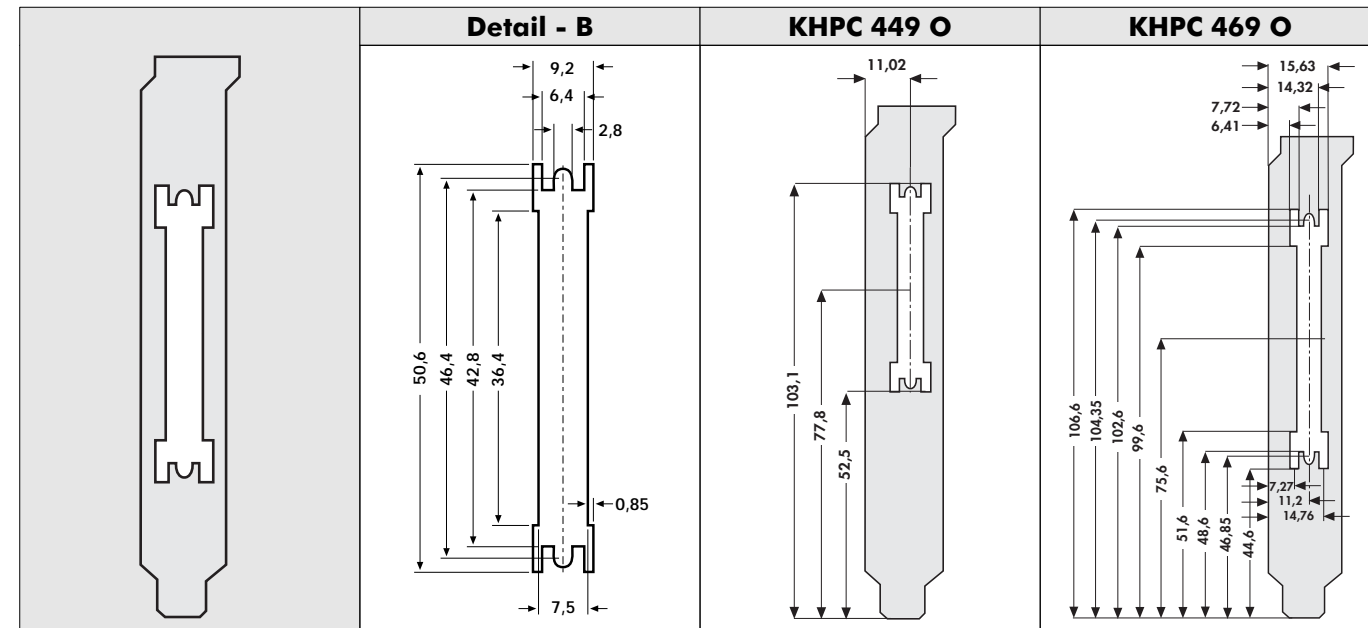
K 52

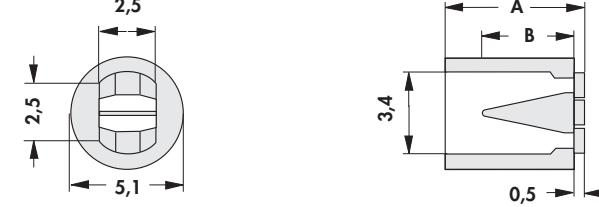

universal mount for LED Ø 3 mm and 5 mm, self retaining

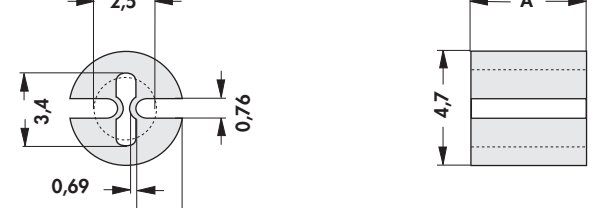
			
art. no.	dim. [mm]	art. no.	dim. [mm]
	A B		A B
MAH 31	3.10 1.50	MAH 71	7.10 4.70
MAH 41	4.10 1.50	MAH 81	8.10 4.70
MAH 51	5.10 1.50	MAH 89	8.90 4.70
MAH 61	6.10 1.50	MAH 99	9.90 7.90
			
art. no.	dim. [mm]	art. no.	dim. [mm]
	A		A
MAH 401	1.00	MAH 406	6.00
MAH 402	2.00	MAH 407	7.00
MAH 403	3.00	MAH 408	8.00
MAH 404	4.00	MAH 409	9.00
MAH 405	5.00	MAH 410	10.00

for LED Ø 3 mm, thin mount

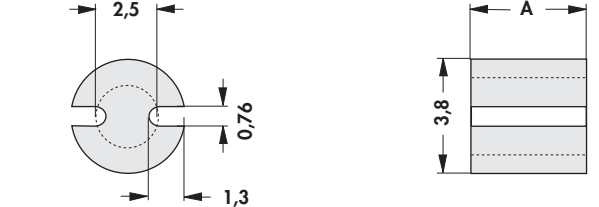
			
art. no.	dim. [mm]	art. no.	dim. [mm]
	A		A
MAH 301	1.00	MAH 306	6.00
MAH 302	2.00	MAH 307	7.00
MAH 303	3.00	MAH 308	8.00
MAH 304	4.00	MAH 309	9.00
MAH 305	5.00	MAH 310	10.00

material: PVC blend, black

temperature range: -40 °C ... +85 °C

flammability: UL 94 V-0

Spacers & mounting strips → L 2 - 3
 LED-hold.for front panel assembly → L 4
 Technical data of the LEDs → L 12
 Light pipes for SMDs → L 9 - 11

LED-holders for PCB assembly → L 5 - 8
 Sockets for LED → F 11 - 12

A

B

for LED Ø 5 mm, self retaining

C

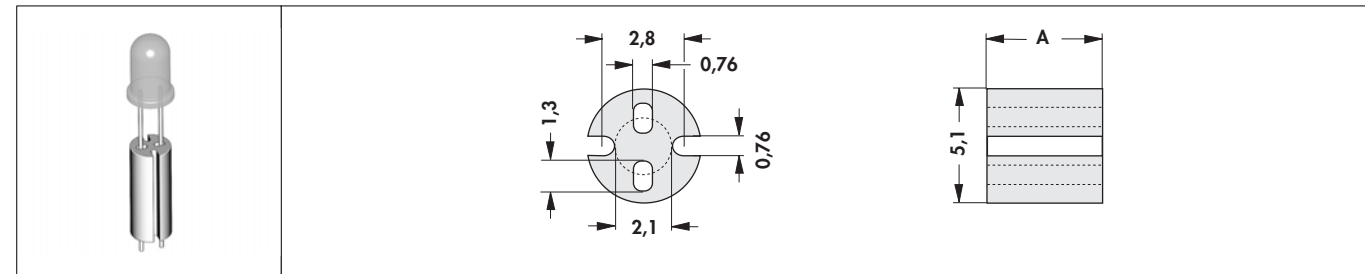

D

art. no.	dim. [mm] A	art. no.	dim. [mm] A
MAH 501	1.00	MAH 506	6.00
MAH 502	2.00	MAH 508	8.00
MAH 503	3.00	MAH 509	9.00
MAH 504	4.00	MAH 510	10.00
MAH 505	5.00		

E

material: PVC blend, black

temperature range: -40 °C ... +85 °C

flammability: UL 94 V-0

F

G

H

I

K

L

M

N

L 3

 Spacers & mounting strips
 LED-holders for PCB assembly
 Technical data of the LEDs
 Light pipes for SMDs

 → L 2 - 3
 → L 5 - 8
 → L 12
 → L 9 - 11

 Light pipes for SMDs
 Sockets for LED
 LED-hold.for front panel assembly

 → L 9 - 11
 → F 11 - 12
 → L 4

suitable for 3 mm diodes with a collar height of 0.6 mm

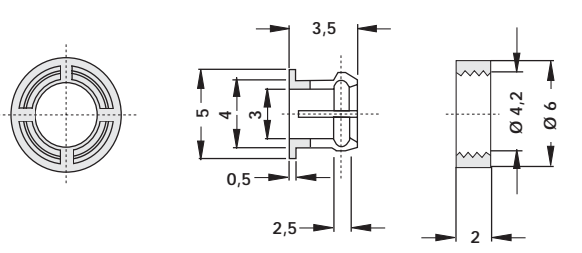
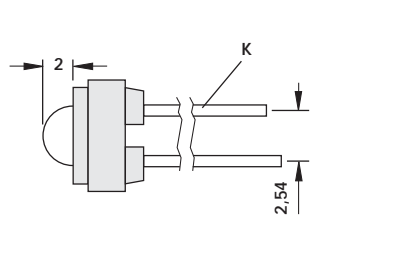
		
art. no. DH 3 V	type for LED Ø 3 mm	

K = cathode

material: glass fibre reinforced polyamide

suitable for 5 mm diodes with a collar height of 0.6 mm/1 mm

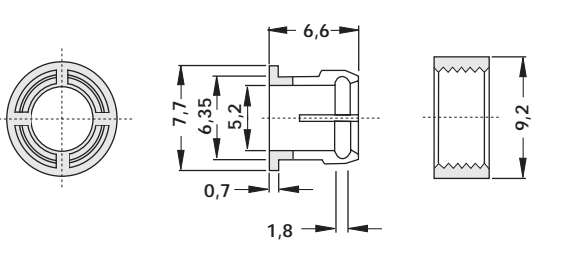
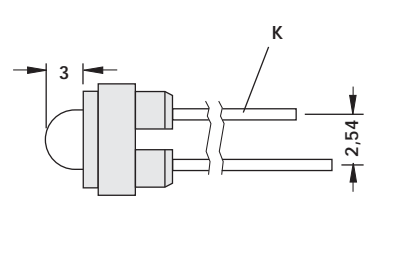
		
art. no. DH 5 VC	type for LED Ø 5 mm	

K = cathode

material: glass fibre reinforced polyamide

suitable for 5 mm diodes with a collar height of 0.6 mm/1 mm

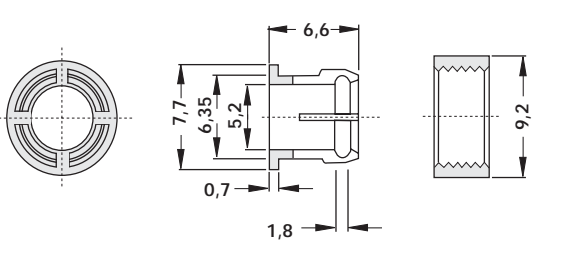
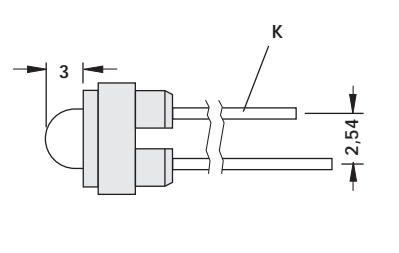
		
art. no. DH 5 SRC	type for LED Ø 5 mm	

material: glass fibre reinforced polyamide

A

B

C

D

E

F

G

H

I



K

L

M

N

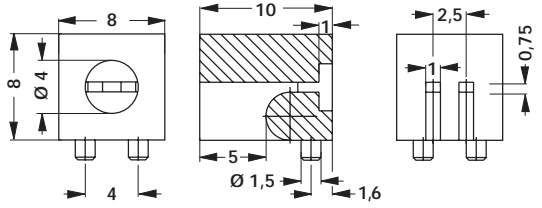
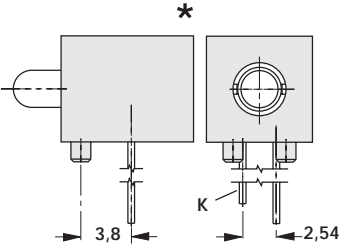
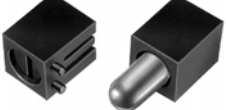
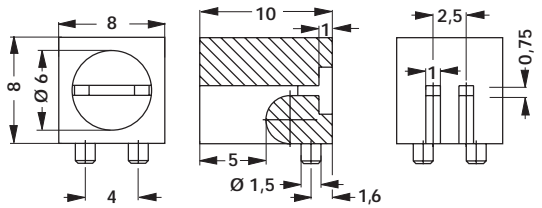
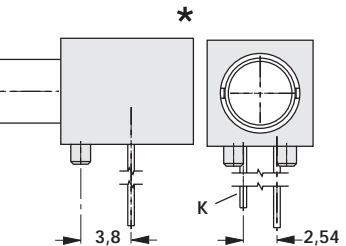
LED-holder for LED Ø 3 mm and 5 mm

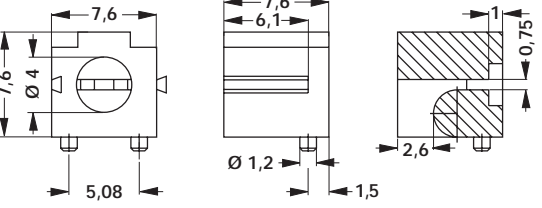
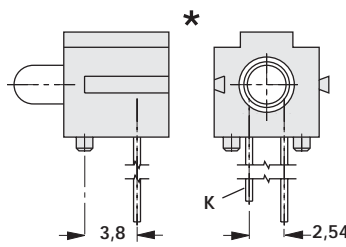
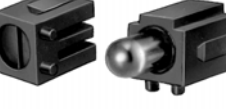
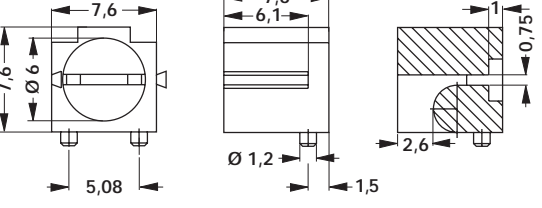
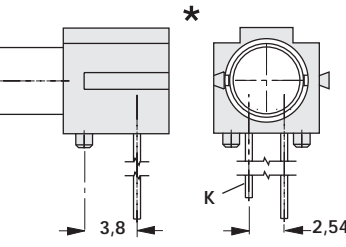
		
<p>art. no. DH 3 W</p>	<p>type for LED Ø 3 mm</p>	
		
<p>art. no. DH 5 W</p>	<p>type for LED Ø 5 mm</p>	
		
<p>art. no. DH 3 R</p>	<p>type for LED Ø 3 mm</p>	
		
<p>art. no. DH 5 R</p>	<p>type for LED Ø 5 mm</p>	

* = presentation with diode

K = cathode

material: glass fibre reinforced polyamide

LED-holder for LED Ø 3 mm

multiple LED-holders: single holder/can be strung, left/can be strung, middle/can be strung, right

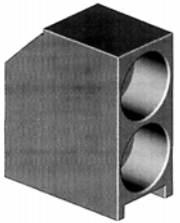
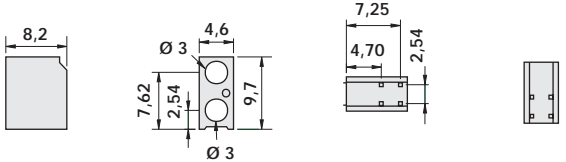
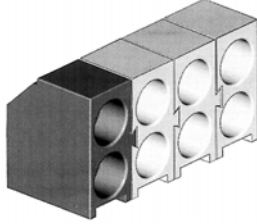
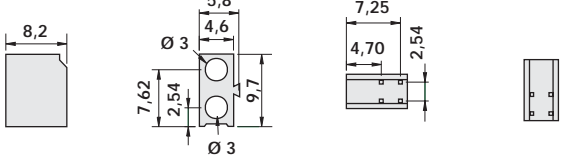
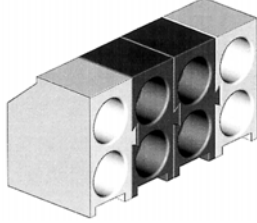
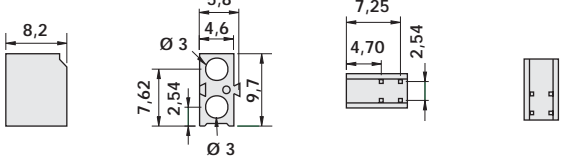
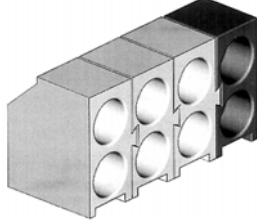
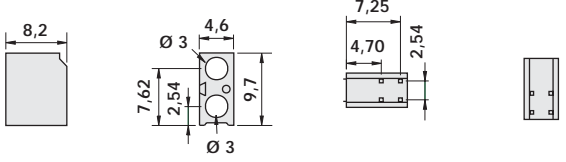
	
art. no. DDH 3 E	type for LED Ø 3 mm
	
art. no. DDH 3 L	type for LED Ø 3 mm
	
art. no. DDH 3 M	type for LED Ø 3 mm
	
art. no. DDH 3 R	type for LED Ø 3 mm

material: nylon, black

temperature range: -20 °C ... +85 °C

flammability: UL 94 V-0

A

B

C

D

E

F

G

H

I

K

L

M

N

Sockets for LED
Screw fastening
D-Sub cut-out cover
Technical data of the LEDs

→ F 11 - 12
→ I 28
→ I 27
→ L 12

Light pipes for SMDs
Spacers & mounting strips
LED-holders for PCB assembly

→ L 9 - 11
→ L 2 - 3
→ L 5 - 8

L 6

LED-holder for LED Ø 5 mm

multiple LED-holders: single holder/can be strung, left/can be strung, middle/can be strung, right

<p>art. no. DDH 5 E</p>	<p>type for LED Ø 5 mm</p>
<p>art. no. DDH 5 L</p>	<p>type for LED Ø 5 mm</p>
<p>art. no. DDH 5 M</p>	<p>type for LED Ø 5 mm</p>
<p>art. no. DDH 5 R</p>	<p>type for LED Ø 5 mm</p>

material: nylon, black

temperature range: -20 °C ... +85 °C

flammability: UL 94 V-0

Fourfold-LED-holders

standard case, diffuse lens, standard colours, space-saving version, round lens, rectangular lens

Technical drawing showing dimensions and pin configurations for the fourfold LED holder. Dimensions include 15, 13,6, 11,3, 9,47, 6,93, 4,39, 1,85, 5,08, 3 x 2,54, 0,5, 2,54, 5,08, and Ø 1,9. Pin configurations are shown as 1-3-5-7 and 2-4-6-8, with a central A-B-C-D label. A circuit symbol for an LED is also provided.

art. no.	type	emission colour
DLH 21 ASEH	with LED Ø 2 mm, fourfold	red
DLH 21 AYEH	with LED Ø 2 mm, fourfold	yellow
DLH 21 AGEH	with LED Ø 2 mm, fourfold	green

material: nylon, black

temperature range: -20 °C ... +85 °C

flammability: UL 94 V-0

A

B

C

D

E

F

G

H

I



K

L

M

N

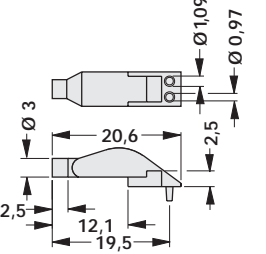
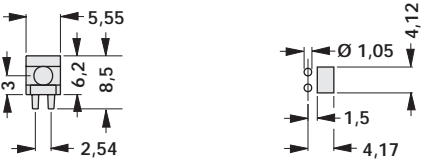
suitable for common SMD types, 3 mm light pipes, horizontal, ESD-protection from panel to PCB

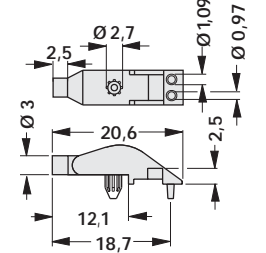
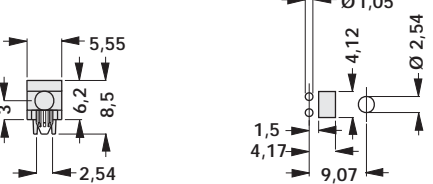
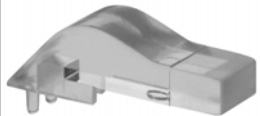
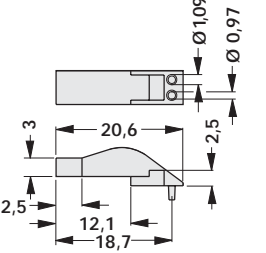
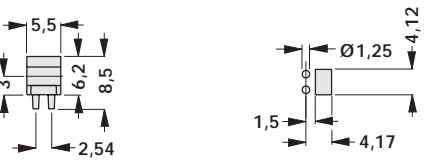
		
<p>art. no. LL 30 HRS</p>	<p>way of fixation by alignment pins</p>	<p>diameter of lense Ø 3 mm</p>
		
<p>art. no. LL 30 HRP</p>	<p>way of fixation by press-in pins</p>	<p>diameter of lense Ø 3 mm</p>
		
<p>art. no. LL 35 HVS</p>	<p>way of fixation by alignment pins</p>	<p>diameter of lense rectangle 5.5x3 mm</p>

material: polycarbonat, clear colour
temperature range: -30 °C ... +100 °C
flammability: UL 94 V-0

suitable for common SMD types, 3 mm light pipes, horizontal, ESD-protection from panel to PCB

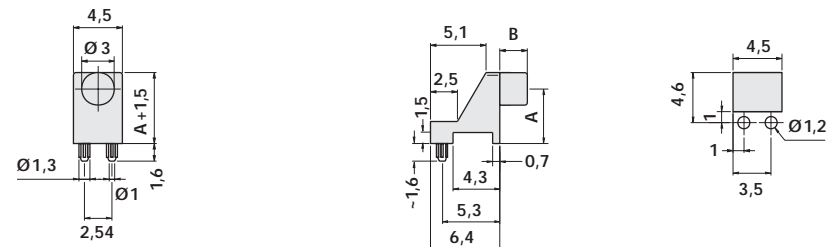
			
	art. no.	way of fixation	dim. [mm]
LL 30 WRFP 038	by press-in pins	A	B
LL 30 WRFP 050	by press-in pins	3.80	2.50
LL 30 WRFP 076	by press-in pins	5.00	2.50
LL 30 WRFP 102	by press-in pins	7.60	2.50
		10.20	2.50

panel light pipe, 6 mm lens, suitable for common SMD LEDs, white lens, large angle of radiation

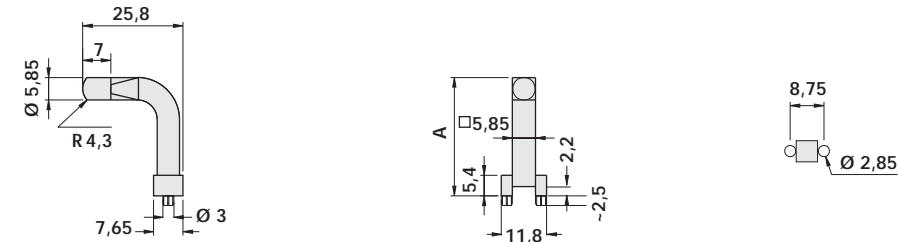
			
	art. no.	way of fixation	dim. [mm]
LL 60 WRB 254	by press-in pins	A	25.40

material: polycarbonat, clear colour

temperature range: -30 °C ... +100 °C

flammability: UL 94 V-0

A

B

C

D

E

F

G

H

I

K



L

M

N

Light pipes for SMDs

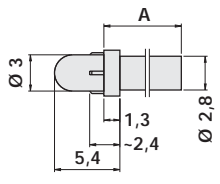
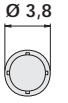
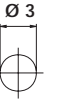
panel light pipe 3 mm, ESD protection from panel to PCB

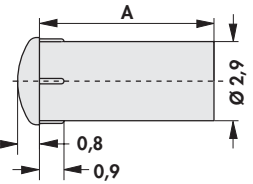
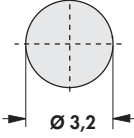
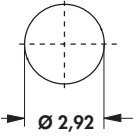
			
art. no.	dim. [mm] A	art. no.	dim. [mm] A
LL 30 PRB 032	3.20	LL 30 PRB 089	8.90
LL 30 PRB 064	6.40		
			
art. no.	dim. [mm] A	art. no.	dim. [mm] A
LL 30 PRL 032	3.20	LL 30 PRL 127	12.70
LL 30 PRL 064	6.40	LL 30 PRL 159	15.90
LL 30 PRL 089	8.90		

material: polycarbonat, clear colour
temperature range: -30 °C ... +100 °C
flammability: UL 94 V-0

suitable for common SMD LEDs, vertical, rigid light pipe Ø 3 mm, ESD protection from panel to PCB

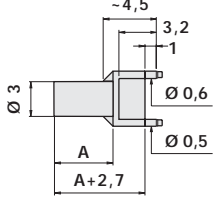
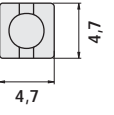
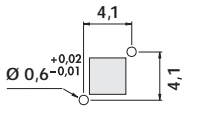
			
art. no.	way of fixation	dim. [mm] A	
LL 30 VRFS 024	by alignment pins	2.40	
LL 30 VRFS 050	by alignment pins	5.00	
LL 30 VRFS 075	by alignment pins	7.50	

material: polycarbonat, clear colour
temperature range: -30 °C ... +100 °C
flammability: UL 94 V-0

X-ON Electronics

Largest Supplier of Electrical and Electronic Components

Click to view similar products for [Headers & Wire Housings](#) category:

Click to view products by [Fisher](#) manufacturer:

Other Similar products are found below :

[95000-104TRLF](#) [10135584-644402LF](#) [DF62W-EP2022PCA](#) [95000-106TRLF](#) [DF62W-2022SCA](#) [DF62W-EP2022PC](#) [2203348](#) [DF62W-2022SC](#) [1084018](#) [1029039](#) [1084017](#) [802-10-012-10-002000](#) [1112640](#) [1112639](#) [000-34000](#) [0009482033](#) [0009507031](#) [57102-S06-03LF](#) [57202-S52-04LF](#) [PCN6-15S-2.5E](#) [0039019024](#) [58102-G61-06LF](#) [582553-1](#) [0009485154](#) [0009508121](#) [0022285053](#) [0050291907](#) [018731A](#) [LY20-4P-DT1-P1E-BR](#) [02.125.8002.8](#) [60101931](#) [60598-1 \(Cut Strip\)](#) [M1625-3R/100](#) [61062-3](#) [61082-181009](#) [636-1427](#) [638009-1](#) [641938-9](#) [641991-4](#) [644168-1](#) [647662-1](#) [65039-019ELF](#) [65817-002LF](#) [65817-015LF](#) [65863-015LF](#) [66207-023LF](#) [67016-026LF](#) [67046-001LF](#) [67095-007LF](#) [67230-005LF](#)