

NHD-0108BZ-FSY-YBW-3V3

Character Liquid Crystal Display Module

NHD- Newhaven Display
0108- 1 line x 8 characters
BZ- Model
F- Transflective
SY- Side Yellow/Green LED Backlight
Y- STN- Yellow/Green
B- 6:00 view
W- Wide Temperature (-20°C~+70°C)
3V3- 3 VDD, 3 Volt Backlight
RoHS Compliant

Newhaven Display International, Inc.

2511 Technology Drive, Suite 101
Elgin IL, 60124

Ph: 847-844-8795 Fax: 847-844-8796

www.newhavendisplay.com

nhtech@newhavendisplay.com

nhsales@newhavendisplay.com

Document Revision History

Revision	Date	Description	Changed by
0	7/29/2008	Initial Release	-
1	10/13/2009	User Guide Reformat	BE
2	10/16/2009	Block Diagram Revision	BE
3	11/20/2009	Optical/Backlight Current Revision	BE
4	12/22/2009	Optical revised	BE
5	6/30/2010	Mechanical drawing updated	MP
6	1/4/2011	Updated alternate controller information	AK
7	4/15/2011	Electrical characteristics updated	AK

Functions and Features

- 1 line x 8 characters
- Built-in controller (ST7066U)
- +3.0V power supply
- 1/8 duty, 1/4 bias
- RoHS compliant

Part No. NHD-0108BZ-FSY-YBW-3V3

Newhaven Display

s, VDD3.0V VLCD3.0V
 e/Transflective/6:00 Visual Angle
 Storage Temp: -30°C~80°C
 Green

SCALE=3.0:1

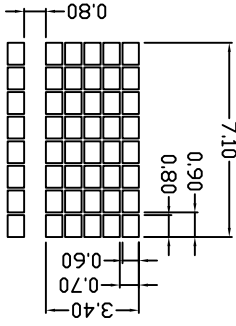

DOTS DETAIL

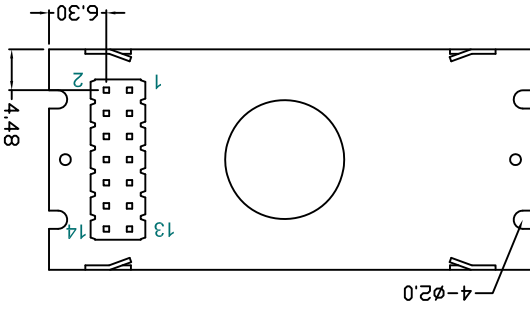

14	DB7
13	DB6
12	DB5
11	DB4
10	DB3
9	DB2
8	DB1
7	DB0
6	E
5	RW
4	RS
3	V0
2	VDD
1	VSS

PIN ASSIGNMENT

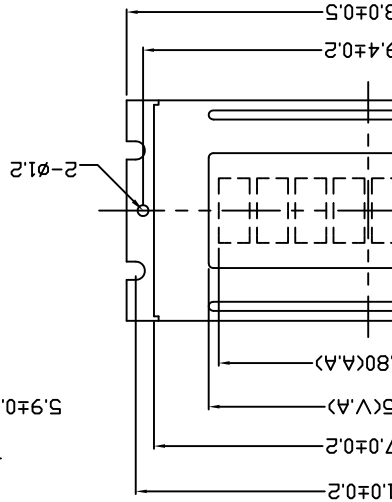
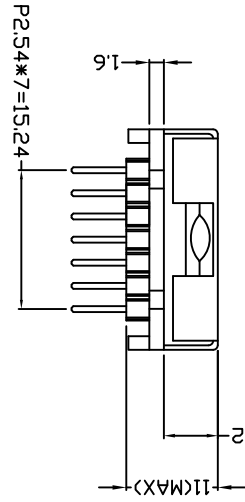

Pin Description and Wiring Diagram

Pin No.	Symbol	External Connection	Function Description
1	VSS	Power Supply	Ground
2	VDD	Power Supply	Supply Voltage for logic and backlight (+3.0V)
3	VO	Adj Power Supply	Power supply for contrast (approx. 0V)
4	RS	MPU	Register select signal. RS=0: Command, RS=1: Data
5	R/W	MPU	Read/Write select signal, R/W=1: Read R/W: =0: Write
6	E	MPU	Operation enable signal. Falling edge triggered.
7-10	DB0 – DB3	MPU	Four low order bi-directional three-state data bus lines. These four are not used during 4-bit operation.
11-14	DB4 – DB7	MPU	Four high order bi-directional three-state data bus lines.

Recommended LCD connector: 2.54mm pitch pins

Backlight connector: --- Mates with: ---

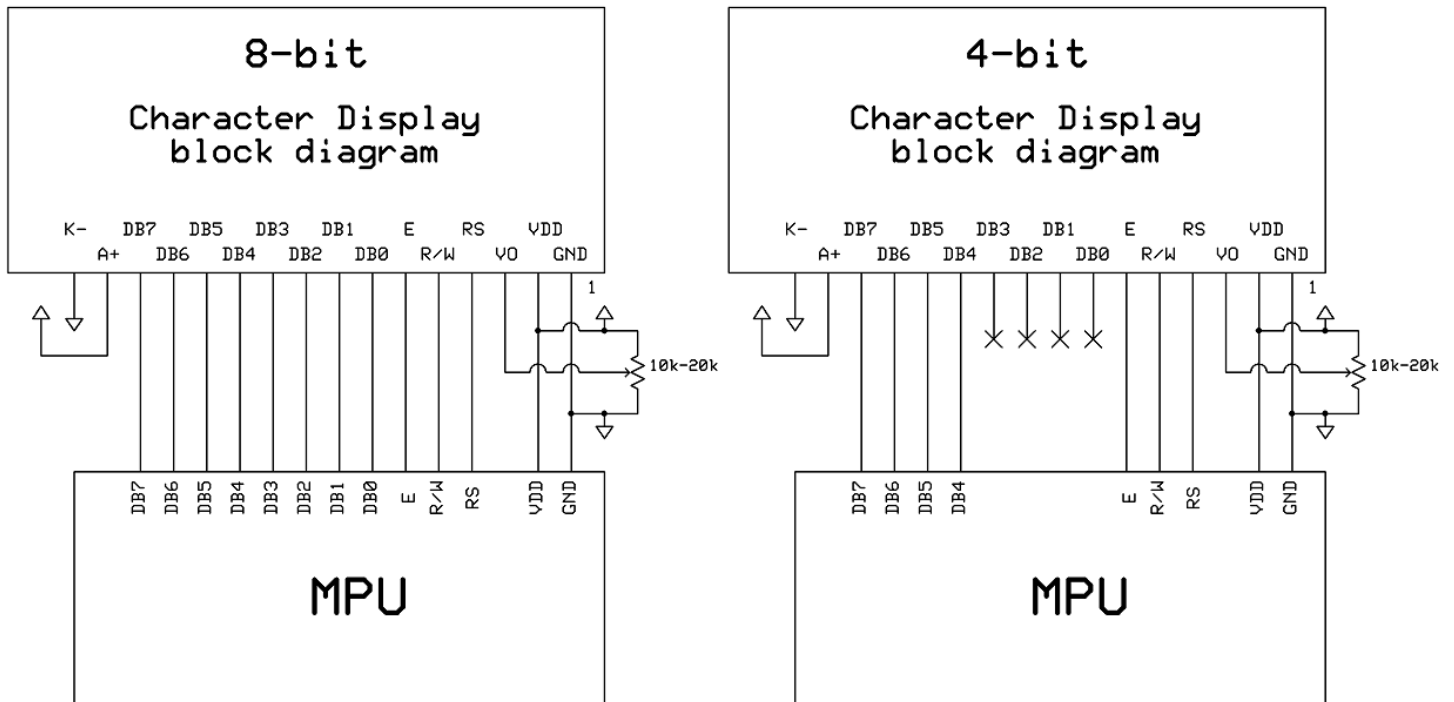

Electrical Characteristics

Item	Symbol	Condition	Min.	Typ.	Max.	Unit
Operating Temperature Range	Top	Absolute Max	-20	-	+70	°C
Storage Temperature Range	Tst	Absolute Max	-30	-	+80	°C
Supply Voltage	VDD		2.7	3.0	3.3	V
Supply Current	IDD	Ta=25°C, VDD=3.0V	-	1.0	1.5	mA
Supply for LCD (contrast)	VDD-V0	Ta=25°C	-	3.0	-	V
"H" Level input	Vih		0.7 VDD	-	VDD	V
"L" Level input	Vil		0	-	0.6	V
"H" Level output	Voh		0.75 VDD	-	-	V
"L" Level output	Vol		-	-	0.2 VDD	V
Backlight Supply Voltage	Vled	-	-	3.0	-	V
Backlight Supply Current	Iled	Vled=3.0V	30	45	60	mA

Optical Characteristics

Item	Symbol	Condition	Min.	Typ.	Max.	Unit
Viewing Angle – Vertical (top)	AV	Cr ≥ 2	-	25	-	°
Viewing Angle -Vertical (bottom)	AV	Cr ≥ 2	-	70	-	°
Viewing Angle – Horizontal (left)	AH	Cr ≥ 2	-	30	-	°
Viewing Angle – Horizontal (right)	AH	Cr ≥ 2	-	30	-	°
Contrast Ratio	Cr		-	2	-	-
Response Time (rise)	Tr	-	-	120	150	ms
Response Time (fall)	Tf	-	-	120	150	ms

Controller Information

Built-in ST7066U. Download specification at http://www.newhavendisplay.com/app_notes/ST7066U.pdf

DDRAM address:

Display position							
1	2	3	4	5	6	7	8
00	01	02	03	04	05	06	07
DDRAM address							

Command Table

Instruction	Instruction Code										Description	Description Time (270KHz)	
	RS	R/W	DB7	DB6	DB5	DB4	DB3	DB2	DB1	DB0			
Clear Display	0	0	0	0	0	0	0	0	0	0	1	Write "20H" to DDRAM. and set DDRAM address to "00H" from AC	1.52 ms
Return Home	0	0	0	0	0	0	0	0	0	1	x	Set DDRAM address to "00H" from AC and return cursor to its original position if shifted. The contents of DDRAM are not changed.	1.52 ms
Entry Mode Set	0	0	0	0	0	0	0	0	1	I/D	S	Sets cursor move direction and specifies display shift. These operations are performed during data write and read.	37 us
Display ON/OFF	0	0	0	0	0	0	0	1	D	C	B	D=1:entire display on C=1:cursor on B=1:cursor position on	37 us
Cursor or Display Shift	0	0	0	0	0	0	1	S/C	R/L	x	x	Set cursor moving and display shift control bit, and the direction, without changing DDRAM data.	37 us
Function Set	0	0	0	0	1	DL	N	F	x	x	x	DL:interface data is 8/4 bits N:number of line is 2/1 F:font size is 5x11/5x8	37 us
Set CGRAM address	0	0	0	1	AC5	AC4	AC3	AC2	AC1	AC0		Set CGRAM address in address counter	37 us
Set DDRAM address	0	0	1	AC6	AC5	AC4	AC3	AC2	AC1	AC0		Set DDRAM address in address counter	37 us
Read Busy flag and address	0	1	BF	AC6	AC5	AC4	AC3	AC2	AC1	AC0		Whether during internal operation or not can be known by reading BF. The contents of address counter can also be read.	0 us
Write data to RAM	1	0	D7	D6	D5	D4	D3	D2	D1	D0		Write data into internal RAM (DDRAM/CGRAM)	37 us
Read data from RAM	1	1	D7	D6	D5	D4	D3	D2	D1	D0		Read data from internal RAM (DDRAM/CGRAM)	37 us

Built-in Font Table

Lower 4 Bits \ Upper 4 Bits	0000	0001	0010	0011	0100	0101	0110	0111	1000	1001	1010	1011	1100	1101	1110	1111
xxxx0000	CG RAM (1)			0	a	P	`	P				-	夕	三	&	P
xxxx0001	(2)		!	1	A	Q	a	q			。	ア	チ	△	△	Q
xxxx0010	(3)		"	2	B	R	b	r			「	イ	ツ	×	⊗	⊗
xxxx0011	(4)		#	3	C	S	c	s			」	ウ	テ	モ	ε	ε
xxxx0100	(5)		\$	4	D	T	d	t			、	エ	ト	⊂	μ	Ω
xxxx0101	(6)		%	5	E	U	e	u			・	オ	ナ	⊂	ε	⊂
xxxx0110	(7)		&	6	F	V	f	v			ヲ	カ	ニ	ヨ	ρ	Σ
xxxx0111	(8)		'	7	G	W	g	w			フ	キ	ヌ	ラ	g	π
xxxx1000	(1)		(8	H	X	h	x			イ	ク	ネ	リ	γ	⊗
xxxx1001	(2))	9	I	Y	i	y			ウ	ケ	ル	ル	γ	γ
xxxx1010	(3)		*	:	J	Z	j	z			エ	コ	ハ	レ	j	≠
xxxx1011	(4)		+	;	K	[k	[オ	サ	ヒ	ロ	*	≠
xxxx1100	(5)		,	<	L	¥	l	l			カ	シ	フ	フ	⊗	⊗
xxxx1101	(6)		-	=	M]	m]			ユ	ス	ハ	ン	⊗	÷
xxxx1110	(7)		.	>	N	^	n	→			ヨ	セ	ホ	°	⊗	
xxxx1111	(8)		/	?	O	_	o	†			ッ	ソ	マ	°	ö	■

Example Initialization Program

8-bit Initialization:

```

/*****/
void command(char i)
{
    P1 = i;                //put data on output Port
    D_I =0;                //D/I=LOW : send instruction
    R_W =0;                //R/W=LOW : Write
    E = 1;
    Delay(1);              //enable pulse width >= 300ns
    E = 0;                 //Clock enable: falling edge
}
/*****/
void write(char i)
{
    P1 = i;                //put data on output Port
    D_I =1;                //D/I=LOW : send data
    R_W =0;                //R/W=LOW : Write
    E = 1;
    Delay(1);              //enable pulse width >= 300ns
    E = 0;                 //Clock enable: falling edge
}
/*****/
void init()
{
    E = 0;
    Delay(100);            //Wait >15 msec after power is applied
    command(0x30);         //command 0x30 = Wake up
    Delay(30);             //must wait 5ms, busy flag not available
    command(0x30);         //command 0x30 = Wake up #2
    Delay(10);             //must wait 160us, busy flag not available
    command(0x30);         //command 0x30 = Wake up #3
    Delay(10);             //must wait 160us, busy flag not available
    command(0x38);         //Function set: 8-bit/2-line
    command(0x10);         //Set cursor
    command(0x0c);         //Display ON; Cursor ON
    command(0x06);         //Entry mode set
}
/*****/
```

4-bit Initialization:

```

/*****/
void command(char i)
{
    P1 = i;                //put data on output Port
    D_I = 0;              //D/I=LOW : send instruction
    R_W = 0;              //R/W=LOW : Write
    Nybble();             //Send lower 4 bits
    i = i<<4;             //Shift over by 4 bits
    P1 = i;                //put data on output Port
    Nybble();             //Send upper 4 bits
}
/*****/
void write(char i)
{
    P1 = i;                //put data on output Port
    D_I = 1;              //D/I=HIGH : send data
    R_W = 0;              //R/W=LOW : Write
    Nybble();             //Clock lower 4 bits
    i = i<<4;             //Shift over by 4 bits
    P1 = i;                //put data on output Port
    Nybble();             //Clock upper 4 bits
}
/*****/
void Nybble()
{
    E = 1;
    Delay(1);              //enable pulse width >= 300ns
    E = 0;                 //Clock enable: falling edge
}
/*****/
void init()
{
    P1 = 0;
    P3 = 0;
    Delay(100);           //Wait >15 msec after power is applied
    P1 = 0x30;            //put 0x30 on the output port
    Delay(30);            //must wait 5ms, busy flag not available
    Nybble();             //command 0x30 = Wake up
    Delay(10);            //must wait 160us, busy flag not available
    Nybble();             //command 0x30 = Wake up #2
    Delay(10);            //must wait 160us, busy flag not available
    Nybble();             //command 0x30 = Wake up #3
    Delay(10);            //can check busy flag now instead of delay
    P1= 0x20;             //put 0x20 on the output port
    Nybble();             //Function set: 4-bit interface
    command(0x28);        //Function set: 4-bit/2-line
    command(0x10);        //Set cursor
    command(0x0F);        //Display ON; Blinking cursor
    command(0x06);        //Entry Mode set
}
/*****/

```

Quality Information

Test Item	Content of Test	Test Condition	Note
High Temperature storage	Endurance test applying the high storage temperature for a long time.	+80°C , 48hrs	2
Low Temperature storage	Endurance test applying the low storage temperature for a long time.	-30°C , 48hrs	1,2
High Temperature Operation	Endurance test applying the electric stress (voltage & current) and the high thermal stress for a long time.	+70°C 48hrs	2
Low Temperature Operation	Endurance test applying the electric stress (voltage & current) and the low thermal stress for a long time.	-20°C , 48hrs	1,2
High Temperature / Humidity Operation	Endurance test applying the electric stress (voltage & current) and the high thermal with high humidity stress for a long time.	+40°C , 90% RH , 48hrs	1,2
Thermal Shock resistance	Endurance test applying the electric stress (voltage & current) during a cycle of low and high thermal stress.	0°C,30min -> 25°C,5min -> 50°C,30min = 1 cycle 10 cycles	
Vibration test	Endurance test applying vibration to simulate transportation and use.	10-55Hz , 15mm amplitude. 60 sec in each of 3 directions X,Y,Z For 15 minutes	3
Static electricity test	Endurance test applying electric static discharge.	VS=800V, RS=1.5kΩ, CS=100pF One time	

Note 1: No condensation to be observed.

Note 2: Conducted after 4 hours of storage at 25°C, 0%RH.

Note 3: Test performed on product itself, not inside a container.

Precautions for using LCDs/LCMs

See Precautions at www.newhavendisplay.com/specs/precautions.pdf

Warranty Information and Terms & Conditions

http://www.newhavendisplay.com/index.php?main_page=terms

X-ON Electronics

Largest Supplier of Electrical and Electronic Components

Click to view similar products for [LCD Character Display Modules & Accessories](#) category:

Click to view products by [Newhaven Display](#) manufacturer:

Other Similar products are found below :

[HG9Z-AC501](#) [HG9Z-SCI25B](#) [HG9Z-XC300](#) [LCD-S401M14TF](#) [LCM-H04002DWN-1G](#) [LCM-S01602DTRA-3](#) [HDM16216L-S-L30S](#)
[HG9Z-XC13A](#) [HG9Z-XC213](#) [C216L01YBW00](#) [LCM-S01602DSF/Q](#) [EA FL-10P](#) [MDLS-161612-G-LV-LED4G](#) [MDLS24265LVLED04](#)
[MDLS-20265-LV-GLED4G](#) [NHD-0420AZ-FSW-GBW-33V33-0](#) [PC2004LRS-AWB-B-Q](#) [CM1644-SGR1](#) [C216W01BBW00](#)
[C420W01NBW00](#) [C220W04NBW00](#) [C220L01YBWR00](#) [C216N04YBW00](#) [G64128W23NBW00](#) [G64128W18NBW00](#) [G64128Z24UBW00](#)
[G64128W20NBW00](#) [G64128W20BBW00](#) [G64128W22BBW00](#) [G64128W25NBW00](#) [162A BC BW](#) [LCM-S02002DSM-Y](#) [MOP-AL202C-](#)
[BYFY-25E-3IN](#) [NHD-0416BZ-FL-GBW-SED](#) [162D BA BC](#) [MDLS-20464-LV-GLED4G](#) [MDLS-40466-G-HV](#) [HDM24216H-2-P9XS](#)
[MIKROE-4169](#) [MDLS-82603-LV-G](#) [MDLS-16263-C-LV-G-LED01G-FFC](#) [VIM-404-DP-RC-S-HV](#) [LCD-S401M16KR](#) [LED4-20265](#) [NHD-](#)
[0440WH-ATFH-JT#](#) [EA 9907-DIP](#) [GLK12232A25SMUSBWBVSE](#) [GLK19264A-7T-1U-USB-FGW](#) [GLK19264A-7T-1U-USB-WB](#)
[GLK12232A25SMUSBGWVSE](#)