

## VIDEO SUPER IMPOSER

### ■ GENERAL DESCRIPTION

The **NJM2207** is video signal superimposer, with synchronous separation circuit, vertical synchronous reproduce circuit and two video high performance switches for switching from video signal to character signal and background signal.

The **NJM2207** is suitable for simply indicating the date time, TV channel and others.

### ■ FEATURES

- Operating Voltage (+4.75V to +13V)
- With Synchronous Separation Circuit
- With Vertical Synchronous Reproduce Circuit
- Package Outline DIP14, DMP14, ZIP16
- Bipolar Technology

### ■ RECOMMENDED OPERATING CONDITION

- Operating Voltage 4.75 to 13V

### ■ PACKAGE OUTLINE

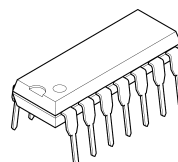

NJM2207D  
(DIP14)

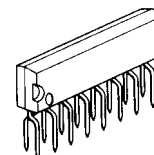

NJM2207S  
(ZIP16)

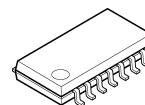

NJM2207M  
(DMP14)

### ■ ABSOLUTE MAXIMUM RATINGS

( $T_a=25^\circ\text{C}$ )

PARAMETER	SYMBOL	RATINGS	UNIT
Supply Voltage	$V^+$	17	V
Power Dissipation	$P_D$	(ZIP16) 500	mW
		(DIP14) 700	mW
		(DMP14) 300	mW
Operating Temperature Range	$T_{opr}$	-40 to +85	$^\circ\text{C}$
Storage Temperature Range	$T_{stg}$	-40 to +125	$^\circ\text{C}$

### ■ ELECTRICAL CHARACTERISTICS

( $T_a=25^\circ\text{C}$ ,  $V^+=5\text{V}$ )

PARAMETER	SYMBOL	TEST CONDITION	MIN.	TYP.	MAX.	UNIT
Operating Current	$I_{CC}$		-	6.5	9	mA
Video Signal Processing Section (Video Input $2V_{PP}$ , Source Resistance=75 $\Omega$ )						
OFF-SET Voltage (Back-ground Input)	$V_{BOS}$	Cross Voltage In Ext.10k $\Omega$ Resistor	-	-	0.1	V
OFF-SET Voltage (Char. Input)	$V_{COS}$	Cross Voltage In Ext.10k $\Omega$ Resistor	-	-	0.1	V
OFF-Voltage (Background Cont. Input)	$V_{BL}$		-	-	0.4	V
OFF-Voltage (Char. Cont. Input)	$V_{CL}$		-	-	0.4	V
ON-Voltage (Background Cont. Input)	$V_{BH}$		2.0	-	-	V
ON-Voltage (Char. Cont. Input)	$V_{CH}$		2.0	-	-	V
Transfer Gain	$G_V$	$R_L=5\text{k}\Omega$	-1	-	+1	dB
Frequency Response	$G_f$	$f=10\text{MHz}$ , $R_L=5\text{k}\Omega$	-	-0.2	-	dB
Crosstalk In Each Signal	$C_T$	Video Input ( $f=3.58\text{MHz}$ )	-	50	-	
		Background Input ( $f=3.48\text{MHz}$ )				
		Char. Input ( $f=3.68\text{MHz}$ )				
		Each Signal. is Sine-Wave $R_L=5\text{k}\Omega$				
Video Differential Phase	DP	$R_L=5\text{k}\Omega$	-	-	3	Deg
Video Differential Gain	DG	$R_L=5\text{k}\Omega$	-	-	3	%

# NJM2207

## ■ ELECTRICAL CHARACTERISTICS SYNC. SEPAATION SECTION

( $T_a=25^{\circ}\text{C}$ ,  $V^+=5\text{V}$ )

PARAMETER	SYMBOL	TEST CONDITION	MIN.	TYP.	MAX.	UNIT
Sync. Sepa. Input Threshold Voltage	$V_{ISP}$	Source Resistance $R_g=75\Omega$	100	140	180	mV
H-Sync. High Level	$V_{HH1}$	$R_L=100\text{k}\Omega$ Pin 3 (13)	4.0	-	-	V
H-Sync. High Level	$V_{HH2}$	$R_L=2.2\text{k}\Omega$ Pin 3 (13)	3.6	4.1	-	V
H-Sync. Low Level	$V_{HL}$	$R_L=2.2\text{k}\Omega$ Pin 3 (13)	-	-	0.1	V
H-Sync. High Level	$V_{FH}$	$R_L=100\text{k}\Omega$ Pin 4 (14)	4.9	-	-	V
H-Sync. Low Level	$V_{FL}$	$R_L=100\text{k}\Omega$ Pin 4 (14)	-	-	0.3	V
V-Sync. High Level	$V_{VH1}$	$R_L=100\text{k}\Omega$ Pin 7 (2)	4.0	-	-	V
V-Sync. High Level	$V_{VH2}$	$R_L=10\text{k}\Omega$ Pin 7 (2)	3.6	4.1	-	V
V-Sync. Low Level	$V_{VL}$	$R_L=10\text{k}\Omega$ Pin 7 (2)	-	-	0.1	V
V-Sync. High Level	$V_{\bar{V}H}$	$R_L=100\text{k}\Omega$ Pin 9 (4)	4.9	-	-	V
V-Sync. Low Level	$V_{\bar{V}L}$	$R_L=100\text{k}\Omega$ Pin 9 (4)	-	-	0.3	V
Schmitt Trigger						
Threshold High Level	$V_{VTH}$	Pin 5 Input Voltage (1)	1.9	2.1	2.3	V
Threshold Low Level	$V_{VTL}$	Pin 5 Input Voltage (1)	1.1	1.3	1.5	V

(Note) : ( ) to DIP-14/DMP-14

## ■ TEST CIRCUIT

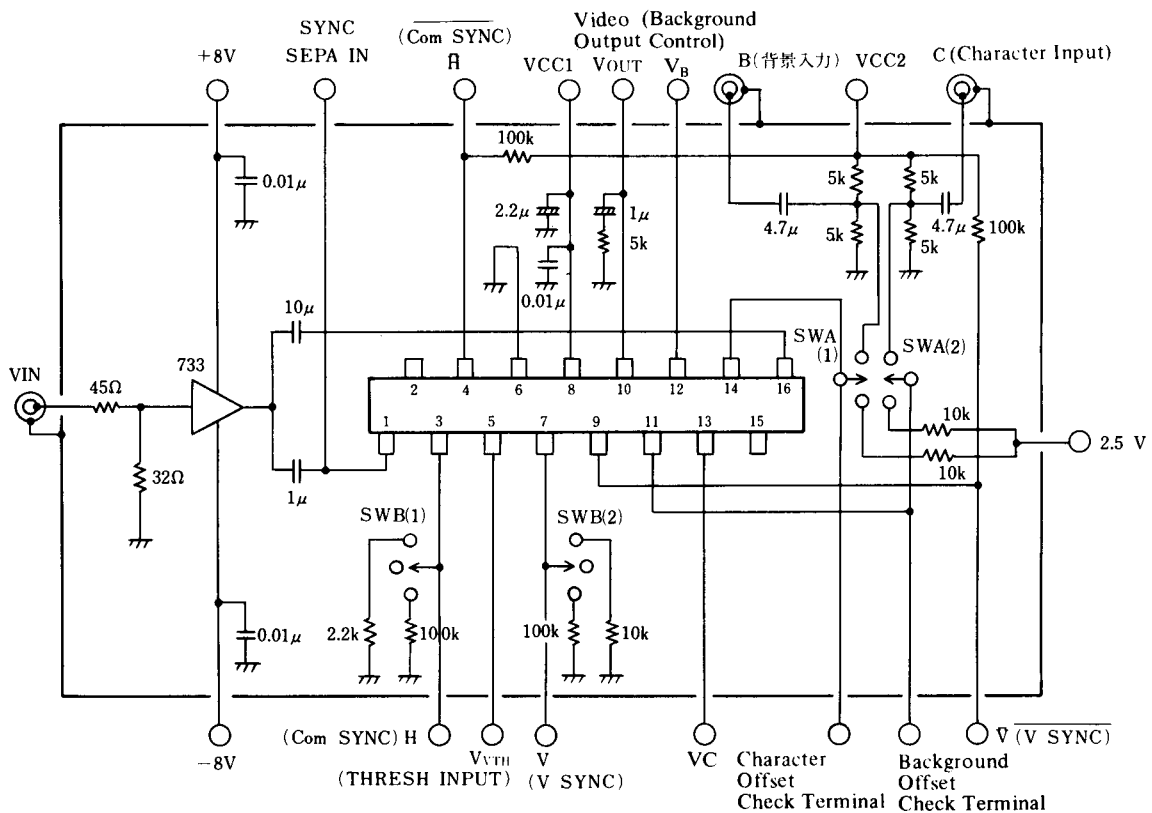

## ■ TYPICAL APPLICATION

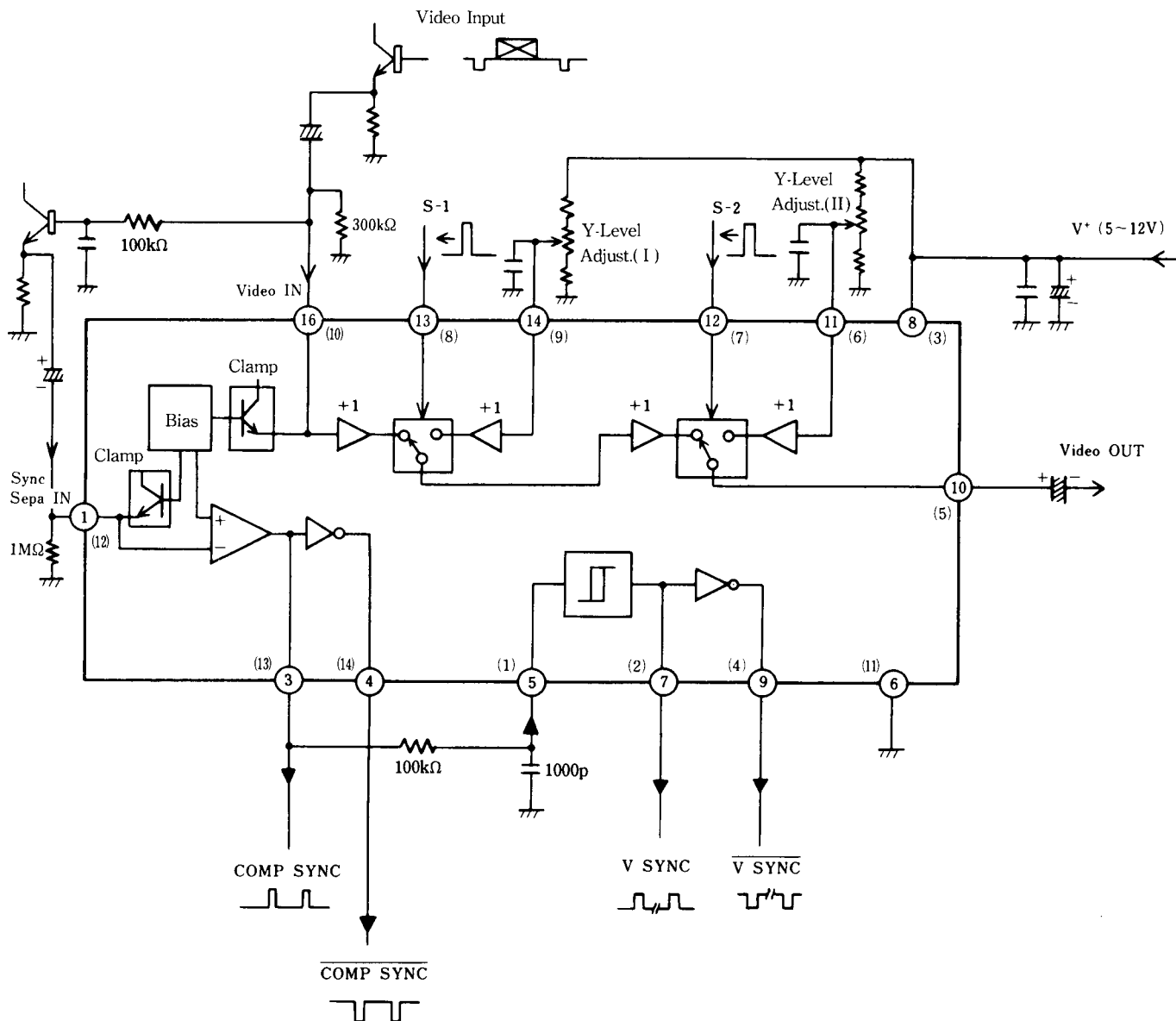

Note 1: Pin Connection to ZIP-16 (Pin 2, Pin 15: NC). ( ) to DIP-14/DMP-14

Note 2: Syn. Sepa. Input Threshold voltage increases 40mV (typ.) when putting 1MΩ in to Pin 1 (Pin 12).

## ■ PRINCIPEL OF CHARACTER SUPERIMPOSER

Basic principle is shown at Fig.1.

Usual TV has video (composite) signal output and input terminals to connect VCR or others. There is all information about picture on video composite signal (Ref. to Fig. 2). Its time signal of horizontal and vertical synchronous signal indicates the brighten place of TV tube. For brightening TV tube regardless video signal, the video input signal has to be switched to DC level (luminance level) on that scanning time. On this method, character is shown with background of usual picture.

Fig.1 Principle of Character Superimposer

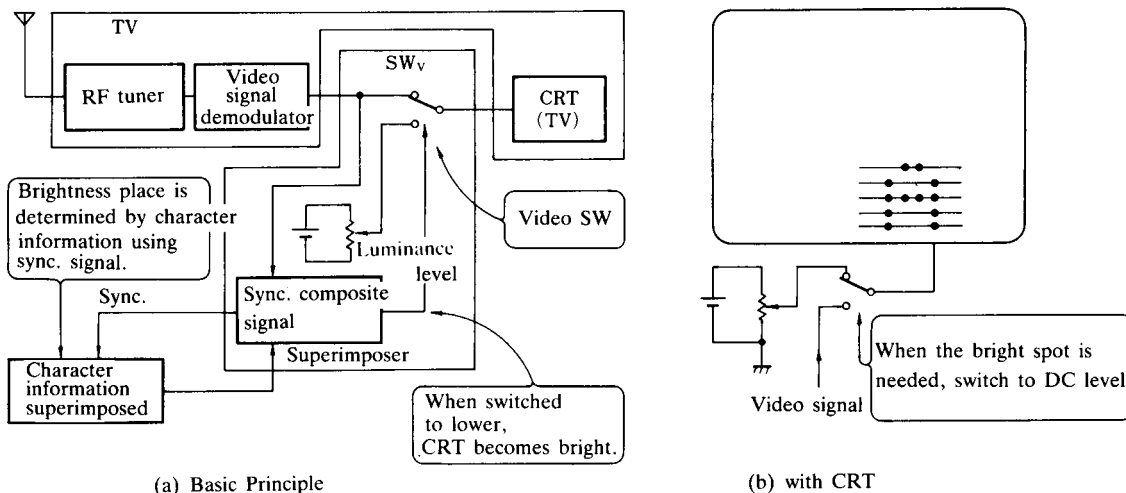
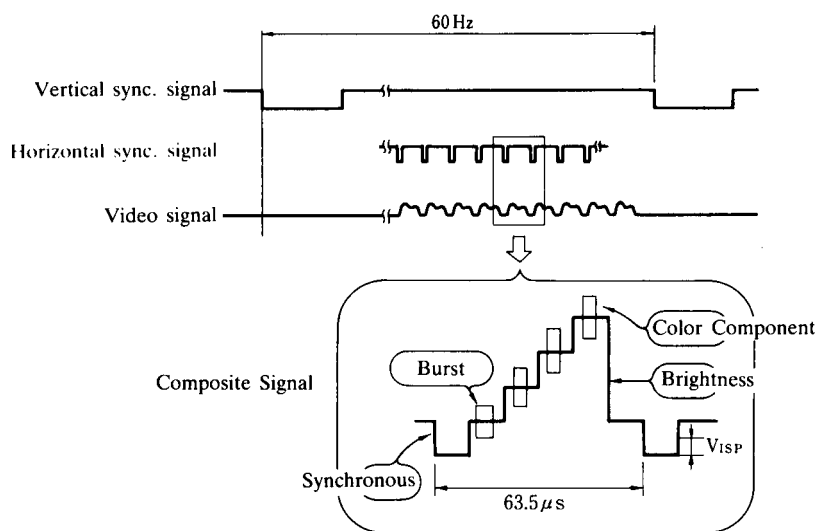

Fig.2 Composite Video Signal



## ■ CIRCUIT CONFIGURATION

Date superimposer circuit configuration on TV is shown at Fig. 3. The NJM2207 includes video switches which convert, usual video signal (horizontal and vertical synchronous signal, video) to signal, of superimposed character given by character generator.

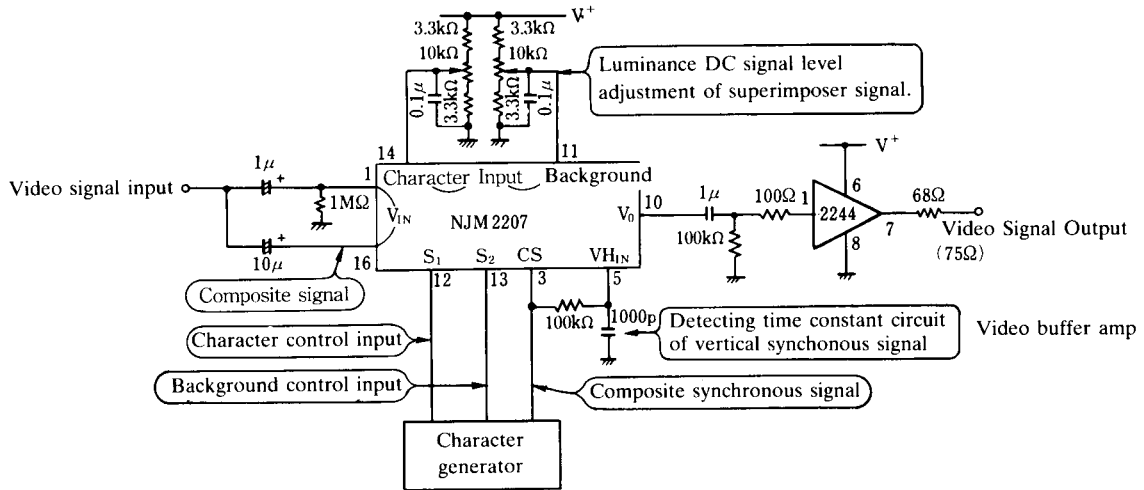
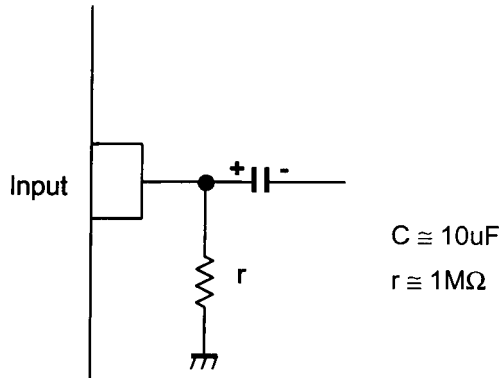

Fig.3 Typical circuit of date superimposer

# NJM2207

## ■APPLICATION

This IC requires 1MΩ resistance between INPUT and GND pin for clamp type input since the minute current causes an unstable pin voltage.



### [CAUTION]

The specifications on this databook are only given for information, without any guarantee as regards either mistakes or omissions. The application circuits in this databook are described only to show representative usages of the product and not intended for the guarantee or permission of any right including the industrial rights.

## X-ON Electronics

Largest Supplier of Electrical and Electronic Components

*Click to view similar products for [Video ICs category](#):*

*Click to view products by [NJR manufacturer](#):*

Other Similar products are found below :

[ADV7343WBSTZ](#) [TW2964-LA2-CR](#) [TW9903-FB](#) [TW9919-PE1-GR](#) [TW9960-TA1-GR](#) [LA9520V-TLM-E](#) [TW9910-NA2-GR](#) [TW9900-TA1-GR](#) [ADV7625KBCZ-8](#) [ADV7626KBCZ-8](#) [MAX9406ETM+T](#) [PI3HDX414FCEEX](#) [PI3HDX511FZLEX](#) [M31245G-15](#)  
[PI3HDX511DZLEX](#) [MAX4895EETE+T](#) [M23428G-33](#) [PI7VD9008ABHFDE](#) [TW2984-NA2-CR](#) [ADV7186BBCZ-RL](#) [ADV7186BBCZ-TL](#)  
[PI3HDMI521FBE](#) [ADV7186BBCZ-T-RL](#) [ADV8003KBCZ-7C](#) [LT6554IGN#PBF](#) [M21324G-13](#) [GS12181-INE3](#) [PI3VDP411LSAZBEX](#)  
[PI3VDP411LSTZBEX](#) [M23145G-14](#) [PI3VDP411LSRZBEX](#) [PI3HDX511EZLSEX](#) [TW2835-BA1-GR](#) [ISL59913IRZ](#) [TW9910-NB2-GR](#)  
[CM5100-01CP](#) [ADV7610BBCZ-RL](#) [BA7653AFV-E2](#) [BA7654F-E2](#) [BA7657F-E2](#) [BH76331FVM-TR](#) [BH76332FVM-TR](#) [BH76363FV-E2](#)  
[TVP5160PNP](#) [MAX9597CTI+](#) [BA7602F-E2](#) [BA7606FS-E2](#) [BA7612F-E2](#) [BA7626F-E2](#) [BA7653AF-E2](#)