

FSK DEMODULATOR / TONE DECODER

■ GENERAL DESCRIPTION

The **NJM2211** is a monolithic phase-locked loop (PLL) system especially designed for data communications. It is particularly well suited for FSK modem applications, and operates over a wide frequency range of 0.01Hz to 300kHz. It can accommodate analog signals between 2mV and 3V, and can interface with conventional DTL, TTL and ECL logic families. The circuit consists of a basic PLL for tracking an input signal frequency within the passband, a quadrature phase detector which provides carrier detection, and an FSK voltage comparator which provides FSK demodulation. External components are used to independently set carrier frequency, bandwidth, and output delay.

■ FEATURES

- Wide Operating Voltage (4.5V to 20V)
- Wide frequency range (0.01Hz to 300kHz)
- DTL / TTL / ECL logic compatibility
- FSK demodulation with carrier-detector
- Wide dynamic range (2mV to 3V_{rms})
- Adjustable tracking range ($\pm 1\%$ to $\pm 80\%$)
- Excellent temperature stability (20ppm / °C typical)
- Package Outline DIP14, DMP14
- Bipolar Technology

■ APPLICATIONS

- FSK demodulation
- Data synchronization
- Tone decoding
- FM detection
- Carrier detection

■ PIN CONFIGURATION

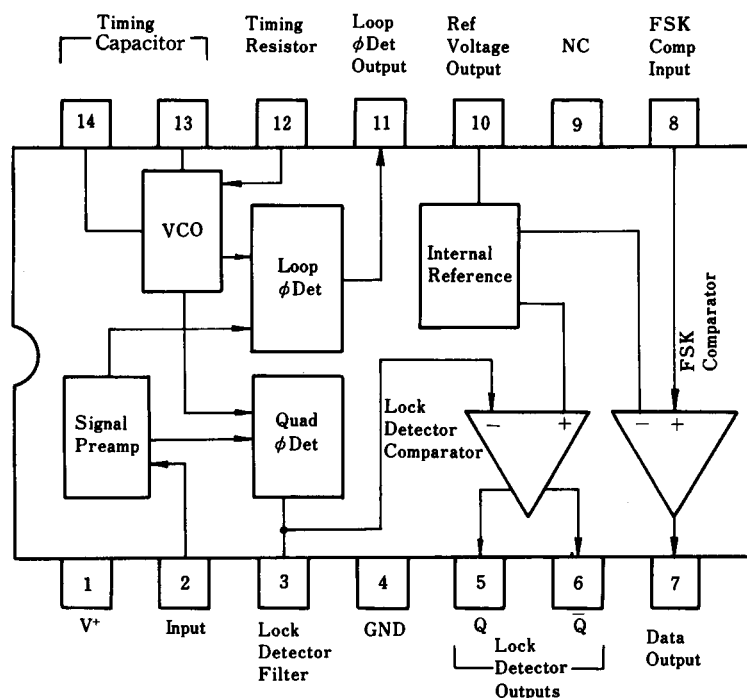

NJM2211D
NJM2211M

■ PACKAGE OUTLINE

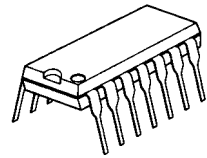

NJM2211D

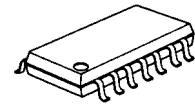

NJM2211M

NJM2211

■ BLOCK DIAGRAM

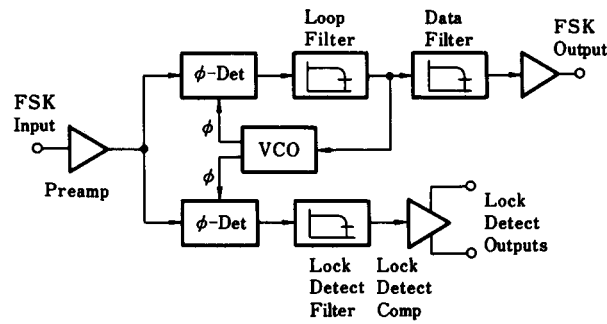

■ ABSOLUTE MAXIMUM RATINGS

($T_a=25^\circ\text{C}$)

PARAMETER	SYMBOL	RATINGS	UNIT
Supply Voltage	V^+	20	V
Input Signal Level	V_{IN}	3	Vrms
Power Dissipation	P_D	(DIP14) 700 (DMP14) 300	mW mW
Operating Temperature Range	T_{opr}	-40 to +85	$^\circ\text{C}$
Storage Temperature Range	T_{stg}	-40 to +125	$^\circ\text{C}$

■ ELECTRICAL CHARACTERISTICS

($V^+=+12V$, $T_a=25^\circ C$)

PARAMETER	SYMBOL	TEST CONDITION	MIN.	TYP.	MAX.	UNIT
Operating Voltage	V^+		4.5	-	20	V
Operating Current	I_{CC}	$R_0 \geq 10k\Omega$	-	5	11	mA
Oscillator						
Frequency Accuracy	Δf_0		-	± 1.0	-	%
Frequency Stability Temp. Coefficient	$\Delta f_0 / \Delta T$	$R_1 = \infty$	-	± 20	-	ppm / $^\circ C$
Power Supply Rejection	PSRR	$V^+ = 12 \pm 1V$ $V^+ = 5 \pm 0.5V$	-	± 0.05 ± 0.2	± 1.5	% / V % / V
Upper Frequency Limit	f_{0MAX}	$R_0 = 8.2k\Omega$, $C_0 = 400pF$	-	300	-	kHz
Lowest Operating Frequency	f_{0MIN}	$R_0 = 2M\Omega$, $C_0 = 50\mu F$	-	0.01	-	Hz
Timing Resistor						
Timing Resistor	R_0	Operating Range	5	-	2000	k Ω
		Recommended Range	15	-	100	k Ω
Loop Phase Detector						
Peak Output Current	I_o	Meas. at pin 11	± 100	± 200	± 300	μA
Output Offset Current	I_{OS}		-	± 2.0	-	μA
Output Impedance	Z_o		-	1.0	-	M Ω
Maximum Voltage Swing	V_{OM}	Ref. to pin 10	± 4.0	± 5.0	-	V
Quadrature Phase Detector						
Peak Output Current	I_o	Meas. at Pin 3	-	150	-	μA
Output Impedance			-	1.0	-	M Ω
Maximum Voltage Swing			-	11	-	V_{P-P}
Input Preamp						
Input Impedance	R_{IN}	Meas. at Pin 2	-	20	-	k Ω
Input Signal Voltage Required to Cause Limiting	V_{IN}		-	2	-	mVrms
Voltage Comparator						
Input Impedance	R_{IN}	Measure at Pin 3 & 8	-	2	-	M Ω
Input Bias Current	I_B		-	100	-	nA
Voltage Gain	G_V	$R_L = 5.1k\Omega$	-	70	-	dB
Output Voltage Low	V_{SAT}	5, 6, 7PIN $I_C = 3mA$	-	0.3	1.0	V
Output Leakage Current	I_{LEAK}	$V_0 = 12V$	-	0.01	11	μA
Internal Reference						
Output Voltage	V_{REF}	Measure at Pin 10	4.75	5.30	5.85	V
Output Impedance	Z_o		-	100	-	Ω

■ EQUIVALENT CIRCUIT

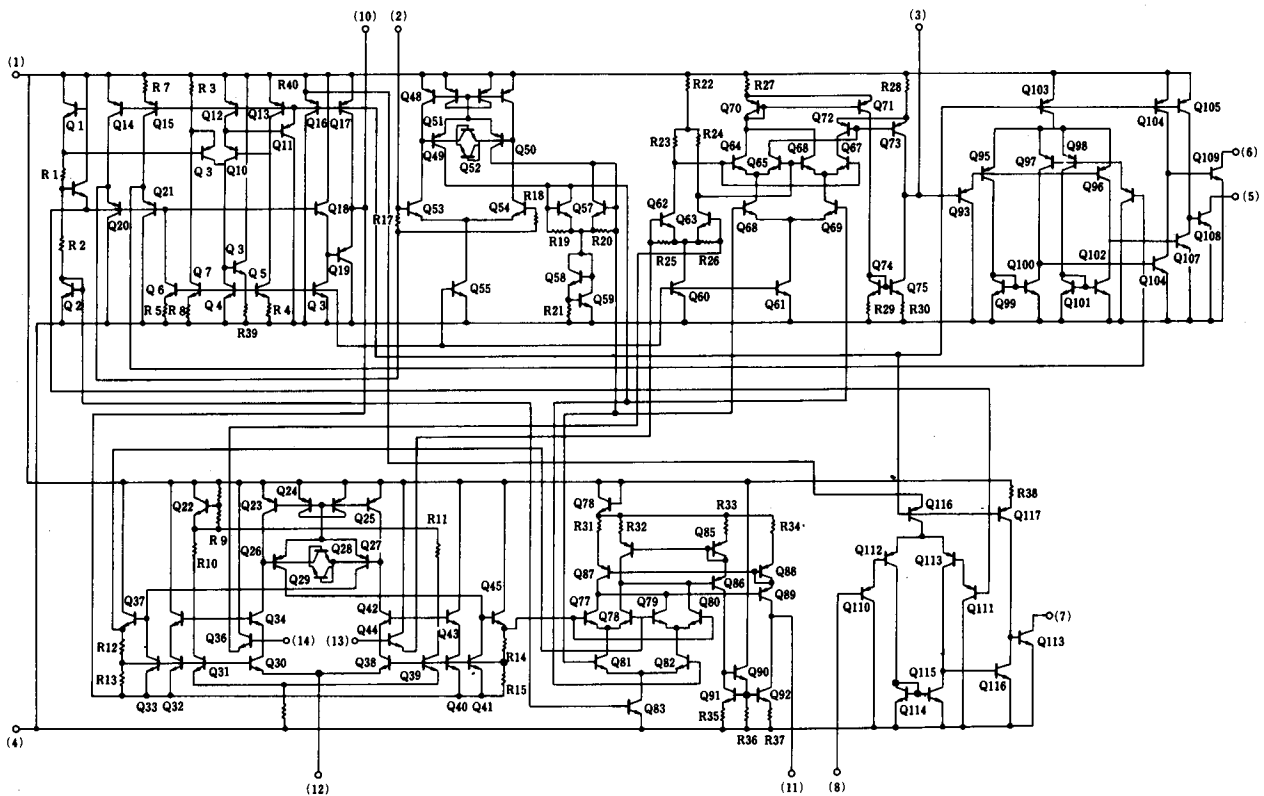

■ CIRCUIT FUNCTION

● Signal Input (Pin 2)

The input signal is AC coupled to this terminal. The internal impedance at pin 2 is 20k Ω , Recommended input signal levels in the range of 10mVrms to 3Vrms.

● Quadrature Phase Detector Output (Pin 3)

This is the high-impedance output of the quadrature phase detector, and is internally connected to the input of lock-detect voltage comparator. In tone detection applications, pin 3 is connected to ground through a parallel combination of R_D and C_D (see Figure 1) to eliminate chatter at the lock-detect outputs. If this tone-detect section is not used, pin 3 can be left open circuited.

● Lock-Detect Output, Q (Pin 5)

The output at pin 5 is at a "high" state when the PLL is out of lock and goes to a "low" or conducting state when the PLL is locked. It is an open collector type output and required a pull-up resistor, R_L , to V^+ for proper operation. In the "low" state it can sink up to 5mA of load current.

● Lock-Detect Complement, Q (Pin 6)

The output at pin 6 is the logic complement of the lock-detect output at pin 5. This output is also an open collector type stage which can sink 5mA of load current in the low or "on" state.

● FSK Data Output (Pin 7)

This output is an open collector logic stage which requires a pull-up resistor, R_L , to V^+ for proper operation. It can sink 5mA of load current. When decoding FSK signals the FSK data output will switch to a "high" or off state for low input frequency, and will switch to a "low" or on state for high input frequency. If no input signal is present, the logic state at pin 7 is indeterminate.

● FSK Comparator Input (Pin 8)

This is the high-impedance input to the FSK voltage comparator. Normally, an FSK post-detection or data filter is connected between this terminal and the PLL phase-detector output (pin 11). This data filter is formed by R_F and C_F of Figure 1. The threshold voltage of the comparator is set by the internal reference voltage, V_R , available at pin 10.

● **Reference Voltage V_R (Pin 10)**

This pin is internally biased at the reference voltage level, V_R ; $V_R = V^+ / 2 - 650\text{mV}$. The DC voltage level at this pin forms an internal reference for the voltage levels at pin 3, 8, 11, and 12. Pin 10 must be bypassed to ground with a $0.1\mu\text{F}$ capacitor.

● **Loop Phase Detector Output (Pin 11)**

This terminal provides a high impedance output for the loop phase-detector. The PLL loop filter is formed by R_1 and C_1 connected to pin 11 (see Figure 1). With no input signal, or with no phase error within the PLL, the DC level at pin 11 is very nearly equal to V_{REF} . The peak voltage swing available at the phase detector output is equal to $\pm V_{REF}$.

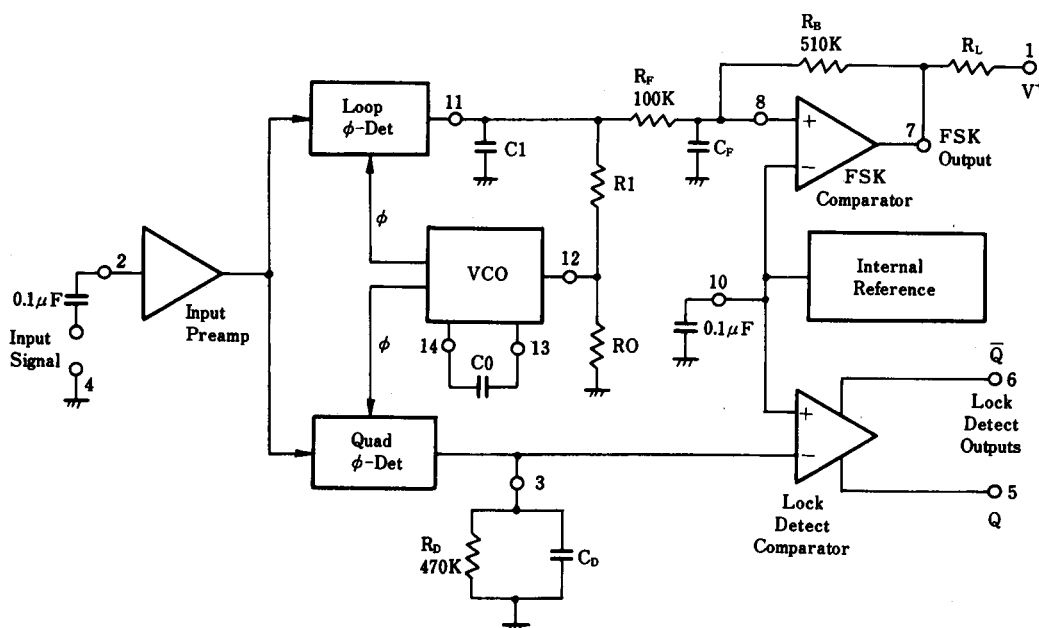

Figure 1. FSK & Tone Detection

● **VCO Control Input (Pin 12)**

VCO free-running frequency is determined by external timing resistor, R_0 , connected from this terminal to ground. The VCO free-running frequency, f_0 , is given by :

$$f_0(\text{Hz}) = \frac{1}{R_0 C_0}$$

where C_0 is the timing capacitor across pins 13 and 14. For optimum temperature stability R_0 must be in the range of $10\text{k}\Omega$ to $100\text{k}\Omega$ (see Typical Electrical Characteristics).

This terminal is a low impedance point, and is internally biased at a DC level equal to V_R . The maximum timing current drawn from pin 12 must be limited to $\leq 3\text{mA}$ for proper operation of the circuit.

● **VCO Timing Capacitor (Pins 13 and 14)**

VCO frequency is inversely proportional to the external timing capacitor, C_0 , connected across these terminals. C_0 must be non-polarized, and in the range of 200pF to $10\mu\text{F}$.

● **VCO Frequency Adjustment**

VCO can be fine tuned by connecting a potentiometer, R_x , in series with R_0 at pin 12 (see Figure 2)

● **VCO Free-Running Frequency, F_0**

The **NJM2211** does not have a separate VCO output terminal. Instead, the VCO outputs are internally connected to the phase-detector sections of the circuit. However, for setup or adjustment purposes, the VCO free-running frequency can be measured at pin 3 (with C_D disconnected) with no input and also pin 2 shorted to pin 10.

■ DESIGN EQUATIONS

See Figure 1 for Definitions of Components.

1. VCO Center Frequency, f_0 :

$$f_0(\text{Hz}) = \frac{1}{R_0 C_0}$$

2. Internal Reference Voltage, V_R (measured at pin 10) :

$$V_R = \left(\frac{+V_S}{2} \right) - 650\text{mV}$$

3. Loop Lowpass Filter Time Constant, τ :

$$\tau = R_1 C_1$$

4. Loop Damping, ξ :

$$\xi = \left(\sqrt{\frac{C_0}{C_1}} \right) \left(\frac{1}{4} \right)$$

5. Loop Tracking Bandwidth, $\pm \Delta f / f_0$:

$$\Delta f / f_0 = R_0 / R_1$$

6. FSK Data Filter Time Constant, T_F :

$$T_F = R_F C_F$$

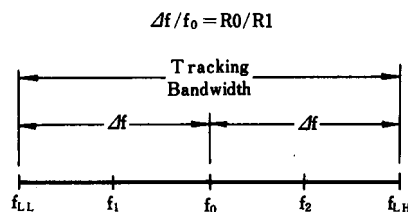

7. Loop Phase Detector Conversion Gain, K_ϕ :

(K_ϕ is the differential DC voltage across pins 10 and 11, per unit of phase error at phase-detector input) :

$$K_\phi \text{ (in volts per radian)} = \frac{(-2)(V_{REF})}{\pi}$$

8. VCO conversion Gain, K_0 , is the amount of change in VCO frequency per unit of DC voltage change at pin 11 :

$$K_0 \text{ (in Hertz per volt)} = \frac{-1}{C_0 R_1 V_{REF}}$$

9. Total Loop Gain K_T :

$$K_T \text{ (in radians per second per volt)} = 2\pi K_\phi K_0 = 4 / C_0 R_1$$

10. Peak Phase-Detector Current, I_A :

$$I_A \text{ (mA)} = \frac{V_{REF}}{25}$$

■ APPLICATIONS

FSK Decoding

Figure 2 shows the basic circuit connection for FSK decoding. With reference to Figures 1 and 2, the functions of external components are defined as follows : R₀ and C₀ set the PLL center frequency. R₁ sets the system bandwidth, and C₁ sets the loop filter time constant and the loop damping factor. C_F and R_F form a one pole post-detection filter for the FSK data output. The resistor R_B (=510kΩ) from pin 7 to pin 8 introduces positive feedback across FSK comparator to facilitate rapid transition between output logic states.

Recommended component values for some of the most commonly used FSK bauds are given in Table 1.

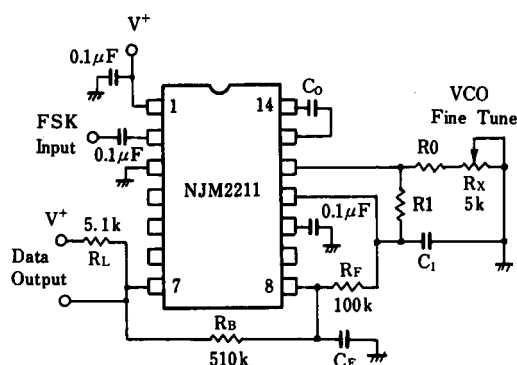

Figure 2. FSK Decoding

Table 1. Recommended Value for FSK

(Ref. Fig. 2)

FSK Band	Component Values
300 Band F ₁ =1070Hz f ₂ =1270Hz	C ₀ =0.039µF C _F =0.005µF C ₁ =0.01µF R ₀ =18kΩ R ₁ =100kΩ
300 Band f ₁ =2025Hz f ₂ =2225Hz	C ₀ =0.022µF C _F =0.005µF C ₁ =0.0047µF R ₀ =18kΩ R ₁ =200kΩ
1200 Band f ₁ =1200Hz f ₂ =2200Hz	C ₀ =0.027µF C _F =0.0022µF C ₁ =0.01µF R ₀ =18kΩ R ₁ =30kΩ

Design Instructions

The circuit of Figure 2 can be tailored for any FSK decoding application by the choice of five key circuit components ; R₀, R₁, C₀, C₁ and C_F. For a given set of FSK mark and space frequencies. f₁ and f₂, these parameters can be calculated as follows :

1. Calculate PLL center frequency, f₀

$$f_0 = \frac{f_1 + f_2}{2}$$

2. Chose a value of timing resistor R₀ to be in the range of 10kΩ to 100kΩ. This choice is arbitrary. The recommended value is R₀ ≅ 20kΩ. The final value of R₀ is normally fine-tuned with the series potentiometer, R_x.

3. Calculate value of C₀ from Design Equation No.1 or from Typical Performance Characteristics :

$$C_0 = 1 / R_0 f_0$$

4. Calculate R₁ to give a Δf equal to the mark-space deviation :

$$R_1 = R_0 [f_0 / (f_1 - f_2)]$$

5. Calculate C₁ to set loop damping. (See Design Equation No.4.)

Normally, ξ ≈ 1 / 2 is recommended

$$\text{Then : } C_1 = C_0 / 4 \text{ for } \xi = 1 / 2$$

6. Calculate Data Filter Capacitance, C_F :

For R_F=100kΩ. R_B=510kΩ, the recommended value of C_F is :

$$C_F (\text{in } \mu\text{F}) = \frac{3}{\text{Band Rate}}$$

Note : All calculated component values except R₀ can be rounded off to the nearest standard value, and R₀ can be varied to fine-tune center frequency through a series potentiometer, R_x (see Figure 2).

NJM2211

Design Example

75 Band FSK demodulator with mark / space frequencies of 1110 / 1170Hz :

Step 1 : Calculate f_0 :

$$f_0 = (1110 + 1170) / 2 = 1140 \text{ Hz}$$

Step 2 : Choose $R_0 = 20 \text{ k}\Omega$ (18k Ω fixed resistor in series with 5k Ω potentiometer)

Step 3 : Calculate C_0 from VCO Frequency vs. Timing Capacitor : $C_0 = 0.044 \mu\text{F}$

Step 4 : Calculate R_1 : $R_1 = R_0 (1140 / 60) = 380 \text{ k}\Omega$

Step 5 : Calculate C_1 : $C_1 = C_0 / 4 = 0.011 \mu\text{F}$

Note : All values except R_0 can be rounded off to nearest standard value.

FSK Decoding With Carrier Detect

The lock-detect section of the **NJM2211** can be used as a carrier detect option for FSK decoding. The recommended circuit connection for this application is shown in Figure 3. The open-collector lock-detect output, pin 6, is shorted to the data output (pin 7). Thus, the data output will be disabled at "low" state, until there is a carrier within the detection band of the PLL, and the pin 6 output goes "high" to enable the data output.

The Minimum value of the lock-detect filter capacitance C_D is inversely proportional to the capture range, $\pm \Delta f_c$. This is the range of incoming frequencies over which the loop can acquire lock and is always less than the tracking range. It is further limited by C_1 . For most applications, $\Delta f_c < \Delta f / 2$, For $R_D = 470 \text{ k}\Omega$, the approximate minimum value of C_D can be determined by :

$$C_D (\mu\text{F}) \geq 16 / \text{capture range in Hz}$$

With values of C_D that are too small, chatter can be observed on the lock-detect output as an incoming signal frequency approaches the capture bandwidth. Excessively large values of C_D will slow the response time of the lock-detect output.

Tone Detection

Figure 4 shows the generalized circuit connection for tone detection. The logic outputs, Q and \bar{Q} at pins 5 and 6 are normally at "high" and "low" logic states, respectively. When a tone is present within the detection band of the PLL, the logic state at these outputs becomes reversed for the duration of the input tone. Each logic output can sink 5mA of load current.

Both logic outputs at pins 5 and 6 are open-collector type stages, and require external pull-up resistors R_{L1} and R_{L2} as shown in Figure 4.

With reference to Figure 1 and 4, the function of the external circuit components can be explained as follows : R_0 and C_0 set VCO center frequency, R_1 sets the detection bandwidth, C_1 sets the lowpass-loop filter time constant and the loop damping factor, and R_{L1} and R_{L2} are the respective pull-up resistors for the Q and \bar{Q} logic outputs.

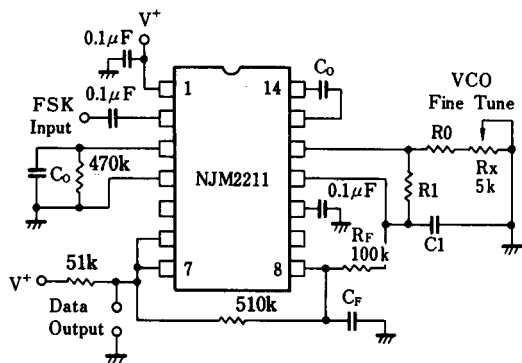

(Data Output is "low" when no carrier is present)

Figure 3. FSK Demodulation with Carrier Detect Capability

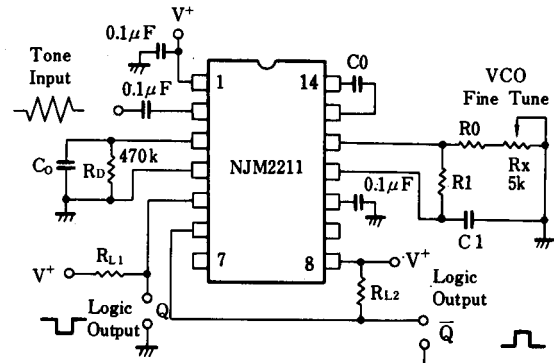

Figure 4. Tone Detection

Design Instructions

The circuit of Figure 4 can be optimized for any tone-detection application by the choice of five key circuit components : R0, R1, C0, C1, and C_D. For a given input tone frequency, f_s, these parameters are calculated as follows :

1. Chose R0 to be in the range of 15kΩ to 100kΩ. This choice is arbitrary.
2. Calculate C0 to set center frequency, f₀ equal to f_s : C0=1 / R0f_s.
3. Calculate R1 to set bandwidth ±Δf (see Design Equation No.5) : R1=R0 (f₀ / Δf)

Note : The total detection bandwidth covers the frequency range of f₀=Δf

4. Calculate value of C1 for a given loop damping factor :

$$C1 = C0 / 16\xi^2$$

Normally $\xi \approx 1 / 2$ is optimum for most tone-detector applications, giving C1=0.25 C0.

Increasing C1 improves the out-of band signal rejection, but increases the PLL capture time.

5. Calculate value of filter capacitor C_D. To avoid chatter at the logic output, with R_D=470kΩ, C_D must be :

$$C_D (\mu F) \geq (16 / \text{capture range in Hz})$$

Increasing C_D slows the logic output response time.

Design Examples

Tone detector with a detection band of 1kHz±20Hz :

Step 1 : Choose R0=20kΩ (18kΩ in series with 5kΩ potentiometer).

Step 2 : Choose C0 for f₀=1kHz : C0 =0.05μF.

Step 3 : Calculate R1 : R1=(R0)(1000 / 20)=1MΩ.

Step 4 : Calculate C1 : for $\xi=1 / 2$, C1=0.25μF, C2=0.013μF.

Step 5 : Calculate C_D : C_D=16 / 38=0.42μF.

Step 6 : Fine tune the center frequency with the 5kΩ potentiometer, R_x.

Linear FM Detection

The **NJM2211** can be used as a linear FM detector for a wide range of analog communications and telemetry applications. The recommended circuit connection for the application is shown in Figure 5. The demodulated output is taken from the loop phase detector output (pin 11), through a post detection filter made up of R_F and C_F, and an external buffer amplifier. This buffer amplifier is necessary because of the high impedance output at pin 11. Normally, a non-inverting unity gain op amp can be used as a buffer amplifier, as shown in Figure 5.

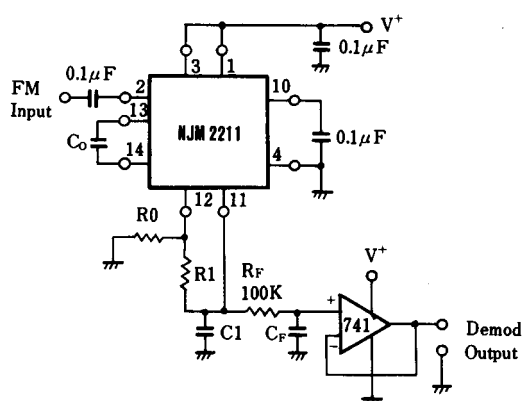

Figure 5. Linear FM Detector

The FM detector gain, i.e., the output voltage change per unit of FM deviation, can be given as :

$$V_{OUT} = R1 V_R / 100 R0 \text{ Volts/\% deviation}$$

where V_R is the internal reference voltage. For the choice of extremal components R1, R0, C_D, C1 and C_F, see the section on Design Equations.

■ TYPICAL CHARACTERISTICS

Operating Current

($T_a = 25^\circ\text{C}$)

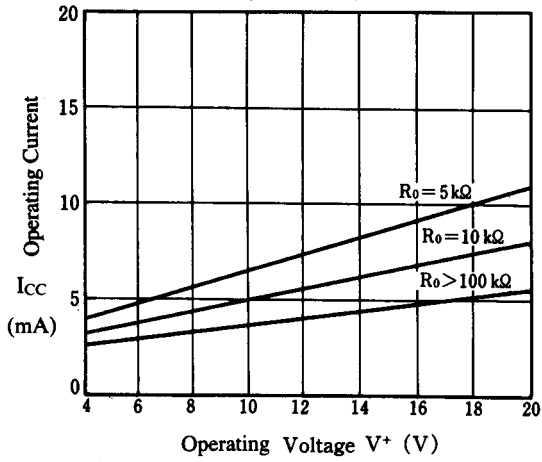

VCO Frequency

($V^+ = 12\text{V}$, $T_a = 25^\circ\text{C}$)

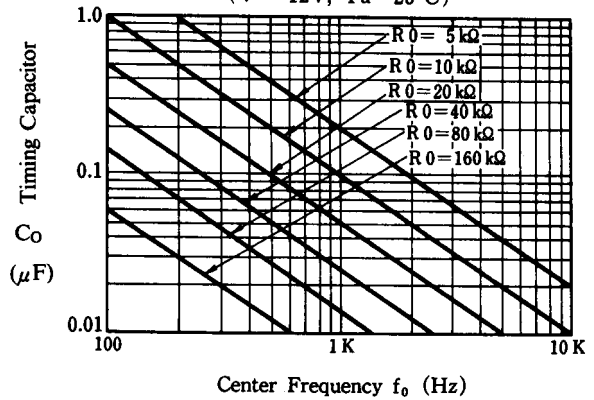

Center Frequency Drift

($V^+ = 12\text{V}$, $R_1 = 10R_0$, $f = 1\text{kHz}$)

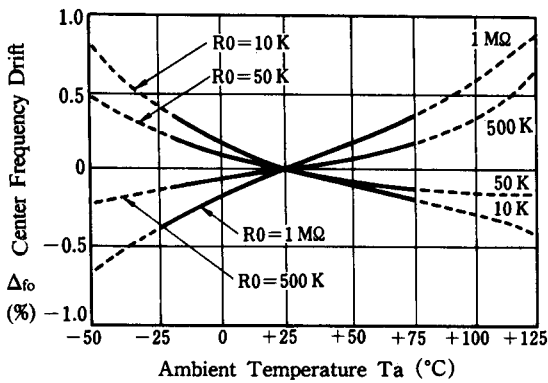

VCO Frequency

($V^+ = 12\text{V}$, $T_a = 25^\circ\text{C}$)

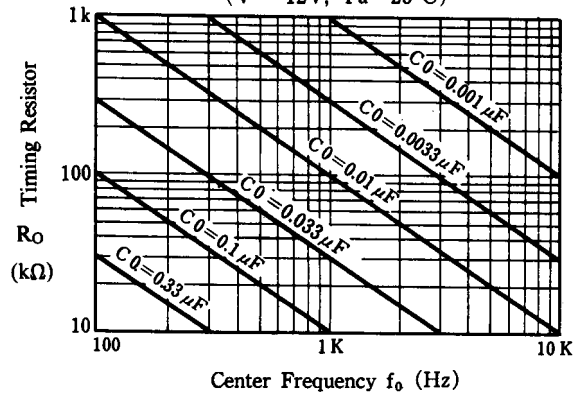

Center Frequency

($f_0 = 1\text{kHz}$, $R \geq 10R_0$, $T_a = 25^\circ\text{C}$)

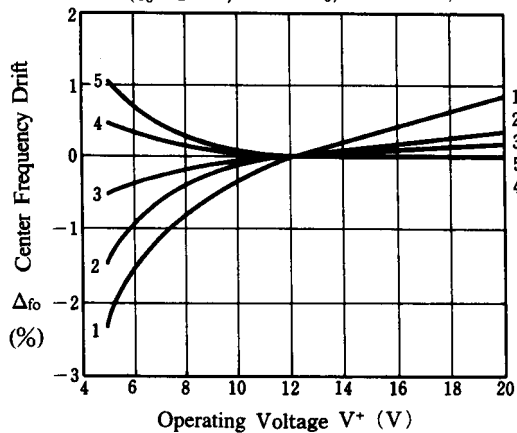

Curve	R_0
1	5 K
2	10 K
3	30 K
4	100 K
5	300 K

[CAUTION]

The specifications on this databook are only given for information, without any guarantee as regards either mistakes or omissions. The application circuits in this databook are described only to show representative usages of the product and not intended for the guarantee or permission of any right including the industrial rights.

X-ON Electronics

Largest Supplier of Electrical and Electronic Components

Click to view similar products for [Modulator/Demodulator](#) category:

Click to view products by [NJR](#) manufacturer:

Other Similar products are found below :

[F1653NLGI](#) [LC72723MA-AH](#) [MAX5862BUXH+](#) [MAX5860FUXH+](#) [SKY73009-11](#) [LC72722PM-TLM-E](#) [NJM2549RB2-TE2](#) [PM-103-PIN](#)
[HMC495LP3TR](#) [MAX2021ETX+](#) [MAX2308ETI+](#) [MAX2306ETI+](#) [MAX2150ETI+](#) [MAX2150ETI](#) [LT5517EUF#PBF](#) [HMC1097LP4ETR](#)
[LT5516EUF#PBF](#) [LT5575EUF#PBF](#) [ADL5373ACPZ-R7](#) [ADRF6821ACPZ](#) [LTC5588IPF-1#PBF](#) [LA72912V-TLM-H](#) [LT5506EUF#PBF](#)
[LT5515EUF#PBF](#) [LT5572EUF#PBF](#) [LT5546EUF#PBF](#) [LTC5585IUF#PBF](#) [LT5528EUF#PBF](#) [TDA8296HN/C1,557](#) [LA72914V-TLM-H](#)
[RFMD2081TR13](#) [LT5502EGN#PBF](#) [CMX7143Q3](#) [ADRF6702ACPZ-R7](#) [031-5](#) [CMX909BD5](#) [CMX589AD5](#) [AD630ADZ](#) [AD630ARZ](#)
[AD630BDZ](#) [AD630JNZ](#) [AD630KNZ](#) [AD630SD](#) [AD630SD/883B](#) [AD8346ARUZ-REEL7](#) [AD8333ACPZ-WP](#) [AD8339ACPZ](#) [AD8345ARE](#)
[AD8345AREZ](#) [AD8345AREZ-RL7](#)