

HIGH PRECISION DC/DC CONVERTER CONTROL IC

■ GENERAL DESCRIPTION

The NJM2360A is a control circuit containing the primary functions required for DC to DC CONVERTOR.

This device consist of high precision reference, comparator controlled duty cycle oscillator with an active current limit circuit, driver and high current output switch.

This IC was specifically designed to be incorporated in step-up, step-down and inverting applications with a minimum number of external components. This IC is designed to be $\pm 5\%$ output voltage by using precision 1% resistance on external detected resistance.

■ FEATURES

- Precision Reference $1.25V \pm 2\%$
- Output Switch Current 1.5A (MAX)
- Operating Voltage $2.5V^*$ to 40V
- Internal Over Current Limit Circuit
- Supply Voltage V^+ $2.5V^*$ to 40V
- Output Voltage V_{OR} 1.25V to 40V
- Oscillator Frequency f_{OSC} 100Hz to 100kHz
- Package Outline DIP8, DMP8

* $T_a = 25^\circ C$. At low temperature, the minimum voltage is 3.0V.

■ PACKAGE OUTLINE

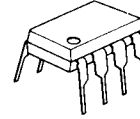

NJM2360AD



NJM2360AM

■ PIN CONFIGURATION

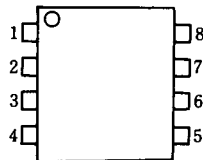

NJM2360AD
NJM2360AM

PIN FUNCTION

1. C_S
2. E_S
3. C_T
4. GND
5. INV_{IN}
6. V^+
7. S_I
8. C_D

■ BLOCK DIAGRAM

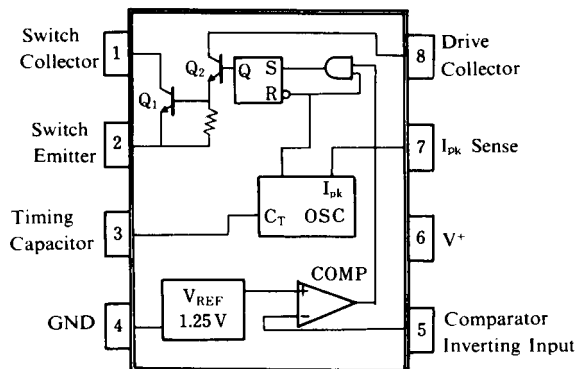

NJM2360A

■ ABSOLUTE MAXIMUM RATINGS

($T_a = 25^\circ\text{C}$)

PARAMETER	SYMBOL	RATINGS	UNIT
Supply Voltage	V^+	40	V
Comparator Input Voltage Range	V_{IR}	-0.3 to 40	V
Power Dissipation	P_D	(DIP8) 875 (DMP8) 750 (note1)	mW mW
Switch Current	I_{SW}	1.5	A
Operating Temperature Range	T_{opr}	-40 to +85	$^\circ\text{C}$
Storage Temperature Range	T_{stg}	-40 to +150	$^\circ\text{C}$

(note 1) At on PC board

■ ELECTRICAL CHARACTERISTICS

● DC Characteristics ($V^+ = 5\text{V}$, $T_a = 25^\circ\text{C}$)

PARAMETER	SYMBOL	TEST CONDITION	MIN.	TYP.	MAX.	UNIT
Operating Current	I_{CC}	$5\text{V} \leq V^+ \leq 40\text{V}$, $C_T = 0.001\mu\text{F}$ $S_1 = V^+$, $INV_{IN} > V_{th}$, $E_S = \text{GND}$	-	2.4	3.5	mA

Oscillator

Charge Current	I_{chg}	$5\text{V} \leq V^+ \leq 40\text{V}$	20	35	50	μA
Discharge Current	I_{dischg}	$5\text{V} \leq V^+ \leq 40\text{V}$	150	200	250	μA
Voltage Swing	V_{OSC}		-	0.5	-	V_{P-P}
Discharge to Charge Current Ratio	I_{dischg}/I_{chg}	$S_1 = V^+$	-	6	-	-
Peak Current Sense Voltage	$V_{IPK(sense)}$	$I_{chg} = I_{dischg}$	250	300	350	mV

Output Switch (Note 2)

Saturation Voltage 1	$V_{CE(sat)1}$	Darlington Connection ($C_S = C_D$) $I_{SW} = 1.0\text{A}$	-	1.0	1.3	V
Saturation Voltage 2	$V_{CE(sat)2}$	$I_{SW} = 1.0\text{A}$, I_C (driver) = 50mA (Forced $\beta=20$)	-	0.5	0.7	V
DC Current Gain	h_{FE}	$I_{SW} = 1.0\text{A}$, $V_{CE} = 5.0\text{V}$	35	120	-	-
Collector Off-State Current	$I_{C(off)}$	$V_{CE} = 40\text{V}$	-	10	-	nA

Comparator

Threshold Voltage	V_{th}		1.225	1.250	1.275	V
Input Bias Current	I_{IB}	$V_{IN} = 0\text{V}$	-	40	400	nA

Note 2 : Output switch tests are performed under pulsed conditions to minimize power dissipation.

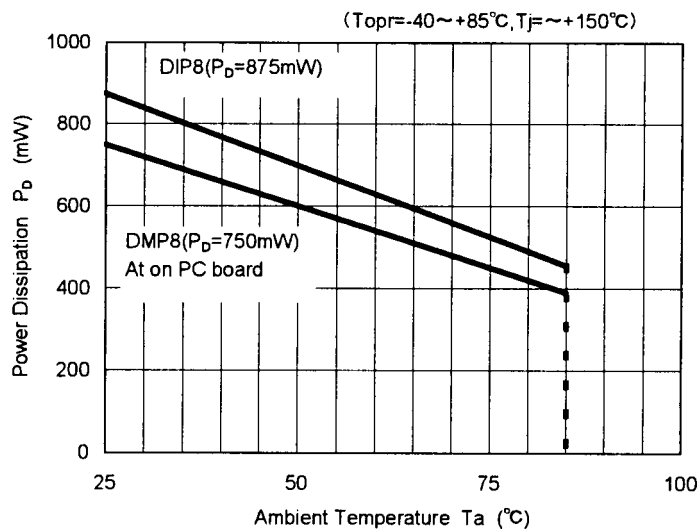

[CAUTION]

The specifications on this databook are only given for information, without any guarantee as regards either mistakes or omissions. The application circuits in this databook are described only to show representative usages of the product and not intended for the guarantee or permission of any right including the industrial rights.

X-ON Electronics

Largest Supplier of Electrical and Electronic Components

Click to view similar products for [Voltage Regulators - Switching Regulators](#) category:

Click to view products by [NJR](#) manufacturer:

Other Similar products are found below :

[LX7186A](#) [622616F](#) [632259F](#) [FAN53610AUC33X](#) [MP2148GQD-33-P](#) [MP2374DS-LF-Z](#) [EN6310QA](#) [NCP81108MNTXG](#)
[NCP81109BMNTXG](#) [L79M05TL-E](#) [FAN48610BUC45X](#) [R3](#) [LV5710GP-TE-L-H](#) [430464BB](#) [455605G](#) [AZ7500BMTR-E1](#) [MIC23156-](#)
[0YML-T5](#) [MIC4930YFL-T5](#) [MP8763GLE-P](#) [KE177614](#) [418569H](#) [455596X](#) [511087D](#) [030908C](#) [063375FB](#) [067501FB](#) [099508GB](#)
[EP5358LUA](#) [NCP81102MNTXG](#) [715715H](#) [FAN48611UC53X](#) [FAN53611AUC12X](#) [MAX809TTR](#) [MAX77596ETBC+T](#)
[MAX77596ETBB+T](#) [MAX16905AUE/V+](#) [NCP6332CMTAATBG](#) [NCV890203MWTXG](#) [LX7176A](#) [ISL8018IRAJZ](#) [MP2162AGQH-Z](#)
[MAX17544ATP+T](#) [EN6360QI](#) [MCP1623T-IMC](#) [MCP1642B-18IMC](#) [MCP1642BT-30I/MS](#) [MCP1642D-50IMC](#) [MCP1642D-50IMS](#)
[MCP1642D-ADJIMC](#) [MC34063LBBGEVB](#)