

## PWM DC/DC CONVERTER IC

### ■GENERAL DESCRIPTION

The **NJM2374A** is a PWM DC/DC converter IC.

It features fixed frequency type PWM control for better noise handling and to avoid intermittent oscillation observed in a simplified controller.

It is suitable for Step-Up, Step-Down and Inverting applications for EMI sensitive application.

### ■PACKAGE OUTLINE

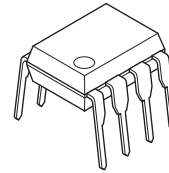

**NJM2374AD**  
( DIP8 )

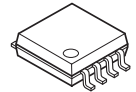

**NJM2374AM**  
( DMP8 )

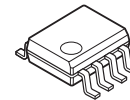

**NJM2374AE**  
( SOP8 )

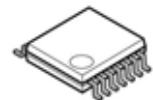

**NJM2374AV**  
( SSOP14 )

### ■FEATURES

- Operating Voltage (2.5V\* to 40V)
- NJM2374AE Operating Voltage (2.5V\* to 48V)
- Wide Oscillator Frequency (100Hz to 100kHz)
- Internal High Power Transistor 1.5A (max.)
- Internal Over Current Limit Circuit
- PWM form Switching Power Supply Control
- Bipolar Technology
- Package Outline DIP8, DMP8, SOP8 JEDEC 150mil  
SSOP14

\*Ta =25°C. At low temperature, the minimum voltage is 3.0V.

### ■PIN CONFIGURATION

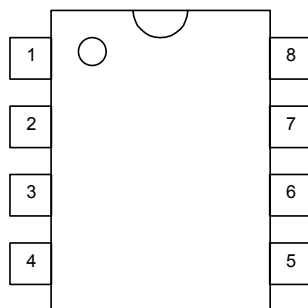

**NJM2374AD**  
**NJM2374AM**  
**NJM2374AE**

#### PIN FUNCTION

- |                   |                    |
|-------------------|--------------------|
| 1. C <sub>S</sub> | 5. IN <sup>+</sup> |
| 2. E <sub>S</sub> | 6. V <sup>+</sup>  |
| 3. C <sub>T</sub> | 7. S <sub>I</sub>  |
| 4. GND            | 8. C <sub>D</sub>  |

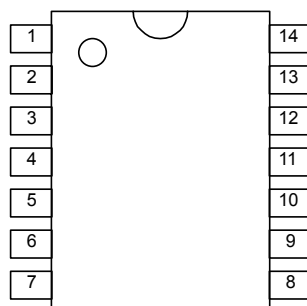

**NJM2374AV**

#### PIN FUNCTION

- |                   |                    |
|-------------------|--------------------|
| 1. C <sub>S</sub> | 8. IN <sup>+</sup> |
| 2. NC             | 9. NC              |
| 3. E <sub>S</sub> | 10. V <sup>+</sup> |
| 4. NC             | 11. NC             |
| 5. C <sub>T</sub> | 12. S <sub>I</sub> |
| 6. NC             | 13. NC             |
| 7. GND            | 14. C <sub>D</sub> |

# NJM2374A

## ■BLOCK DIAGRAM

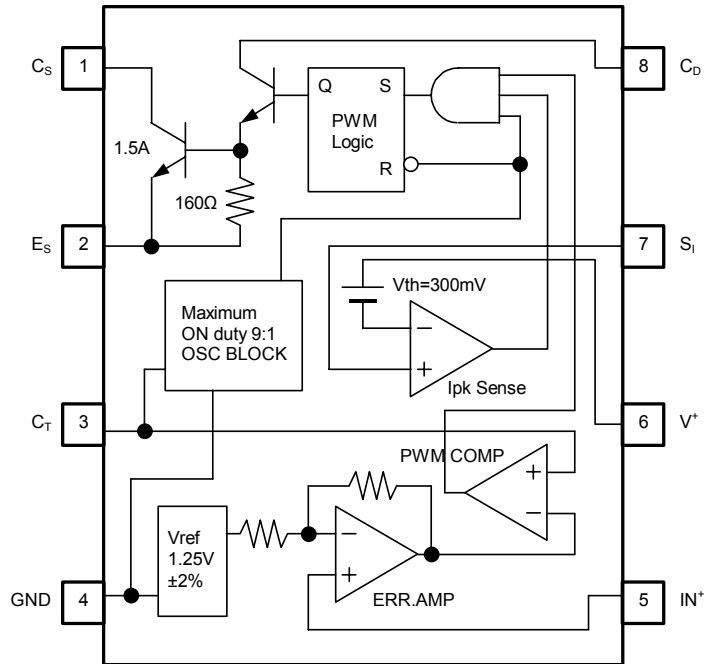

(DIP8, DMP8, SOP8: PACKAGE)

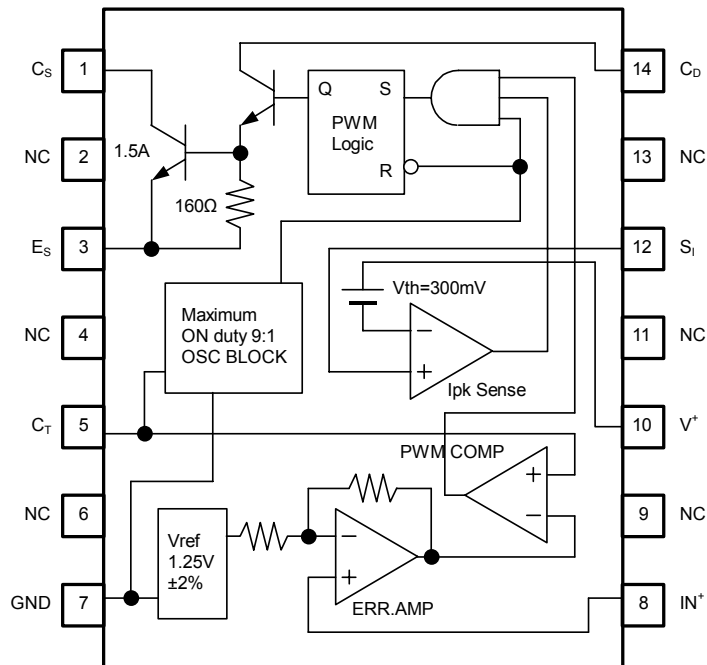

(SSOP14: PACKAGE)

## ■ABSOLUTE MAXIMUM RATINGS

(Ta=25°C)

| PARAMETER                   | SYMBOL           | RATINGS  | UNIT |
|-----------------------------|------------------|--|------|
| Maximum Supply Voltage      | V <sup>+</sup>   | 40<br>(NJM2374AE: 48V)   | V    |
| Output Switch Current       | I <sub>SW</sub>  | 1.5  | A    |
| Output Switch Voltage       | V <sub>SW</sub>  | 40<br>(NJM2374AE: 48V)   | V    |
| Comparator Input Voltage    | V <sub>IR</sub>  | -0.3 ~ 40<br>(NJM2374AE: 48V)  | V    |
| Power Dissipation           | P <sub>D</sub>   | (DIP8) 875<br>(DMP8) 750 (note1)<br>(SOP8) 1,000 (note1)<br>(SSOP14) 375 | mW   |
| Operating Temperature Range | T <sub>opr</sub> | -40 ~ +85  | °C   |
| Storage Temperature Range   | T <sub>stg</sub> | -50 ~ +150   | °C   |

(note1) At on PC board.

In the case of Step-Down and Inverting Conversion with the internal power transistor, the Output Voltage must be set lower than 6V(-6V).

## ■POWER DISSIPATION vs. AMBIENT TEMPERATURE

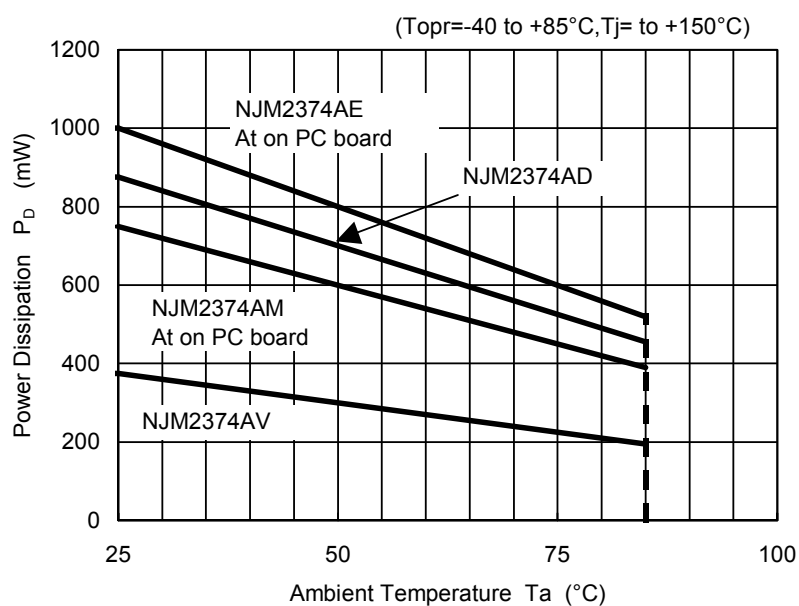

In the case of SSOP packaging, the power dissipation should carefully be considered when designing this parts.

# NJM2374A

## ■ELECTRICAL CHARACTERISTICS

DC Characteristics ( $V^+=5V$ ,  $T_a=25^\circ C$ )

| PARAMETER                               | SYMBOL       | TEST CONDITIONS  | MIN.  | TYP.  | MAX.  | UNIT      |
|---|--------------|--|-------|-------|-------|-----------|
| Operating Current 1                     | $I_{CC1}$    | $C_T=1nF$ , $S_I=V^+$ , $IN^+ > V_{th}$ , $E_S=GND$                | –     | 2.8   | 4.0   | mA        |
| Operating Current 2<br>(NJM2374AE Only) | $I_{CC2}$    | $V^+=48V$ , $C_T=1nF$ , $S_I=V^+$ ,<br>$IN^+ > V_{th}$ , $E_S=GND$ | –     | 3.4   | 4.5   | mA        |
| Charge Current                          | $I_{chg}$    |  | 12    | 20    | 30    | $\mu A$   |
| Discharge Current                       | $I_{dis}$    |  | 110   | 180   | 300   | $\mu A$   |
| Voltage Swing                           | $V_{OSC}$    |  | –     | 0.5   | –     | $V_{P-P}$ |
| Discharge to Charge<br>Current Ratio    | $I_{ratio}$  | $S_I=V^+$  | –     | 9     | –     | –         |
| Peak Current<br>Sense Voltage           | $V_{ipk}$    | $I_{chg}=I_{dis}$  | 250   | 300   | 350   | mV        |
| Saturation Voltage 1                    | $V_{sat1}$   | Darlington Connection<br>( $C_S=C_D$ ), $I_{SW}=0.7A$              | –     | 1.0   | 1.3   | V         |
| Saturation Voltage 2                    | $V_{sat2}$   | $I_{SW}=0.7A$ , $I_c(driver)=50mA$<br>(Forced $\beta \approx 14$ ) | –     | 0.5   | 0.7   | V         |
| Output Transistor<br>Bias Resistance    | $R_{bias}$   |  | –     | 160   | –     | $\Omega$  |
| DC Voltage Gain                         | $h_{FE}$     | $I_{SW}=0.7A$ , $V_{CE}=5.0V$                                      | 35    | 120   | –     | –         |
| Collector Off-State<br>Current          | $I_{C(off)}$ | $V_{CE}=40V$<br>(NJM2374AE: $V_{CE}=48V$ )                         | –     | 10    | –     | nA        |
| Threshold Voltage                       | $V_{th}$     |  | 1.225 | 1.250 | 1.275 | V         |
| Input Bias Current                      | $I_B$        | $IN^+=0V$  | –     | 40    | 400   | nA        |

(note) Output switch tests are performed under pulsed conditions to minimize power dissipation.

## ■TIMING CHART

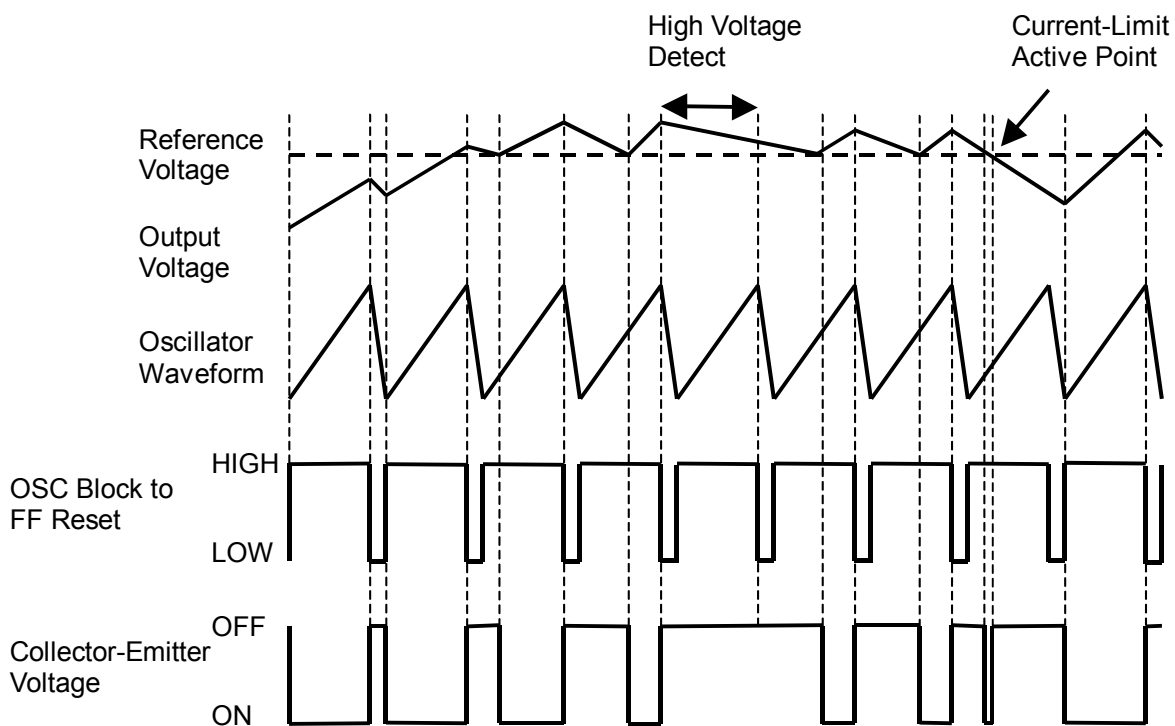

## ■ TYPICAL CHARACTERISTICS

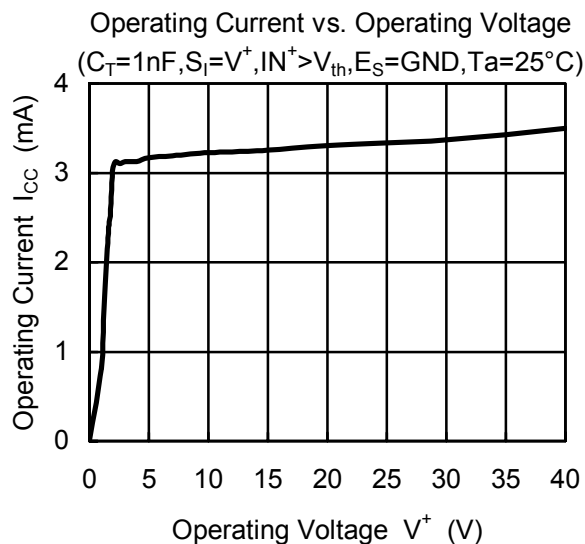
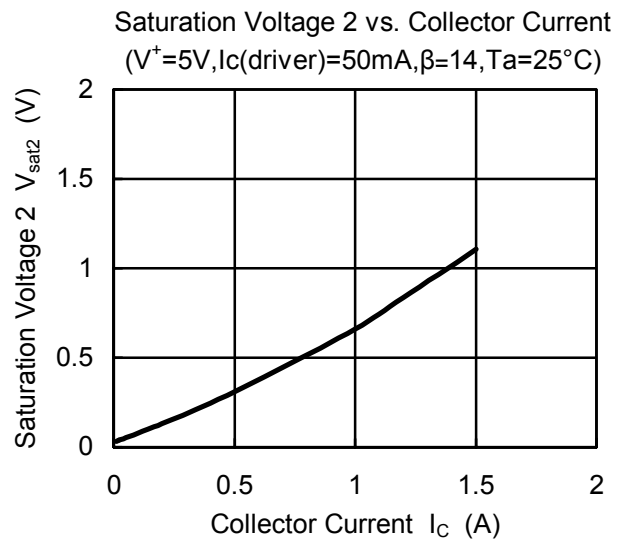
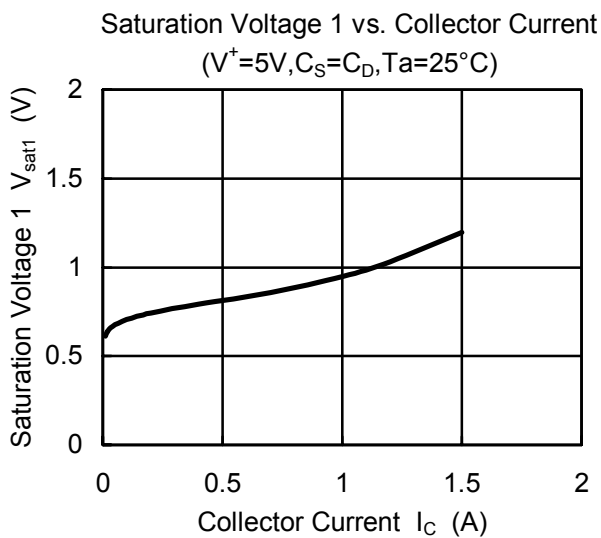
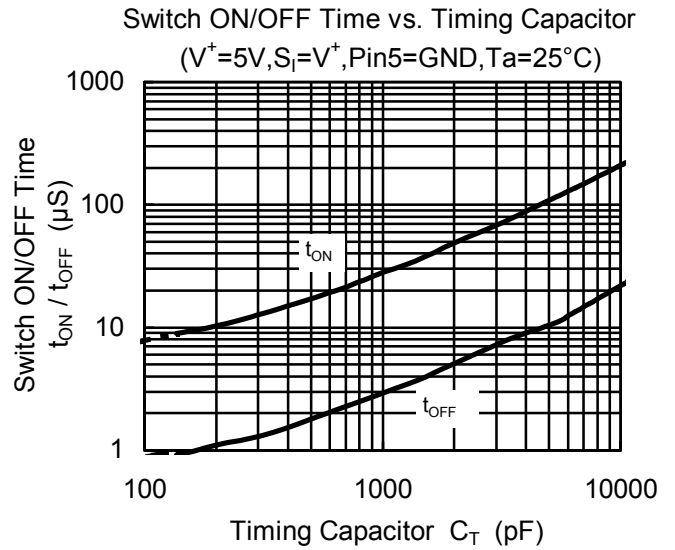
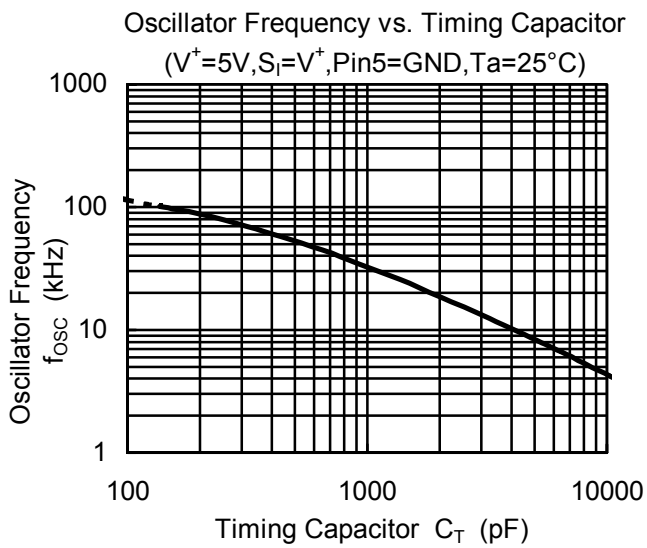

## ■ TYPICAL CHARACTERISTICS

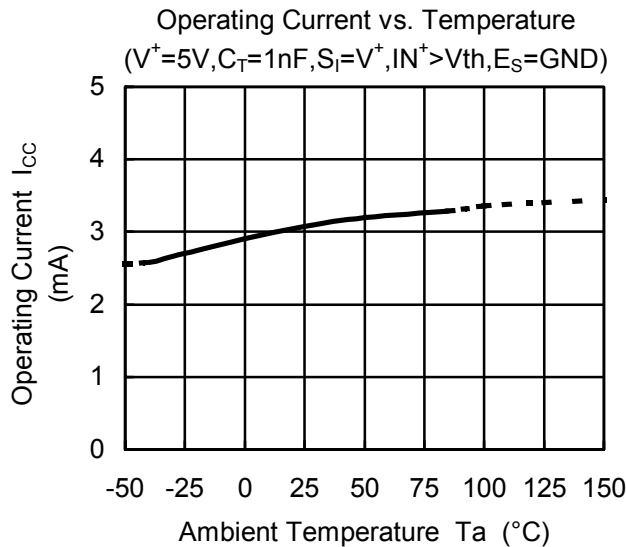
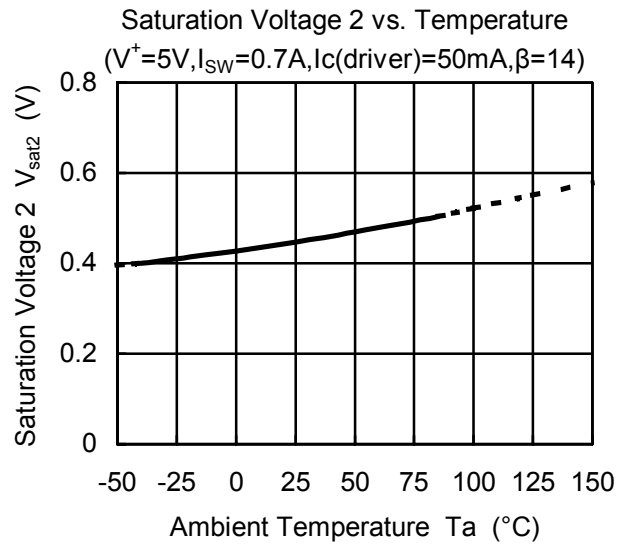
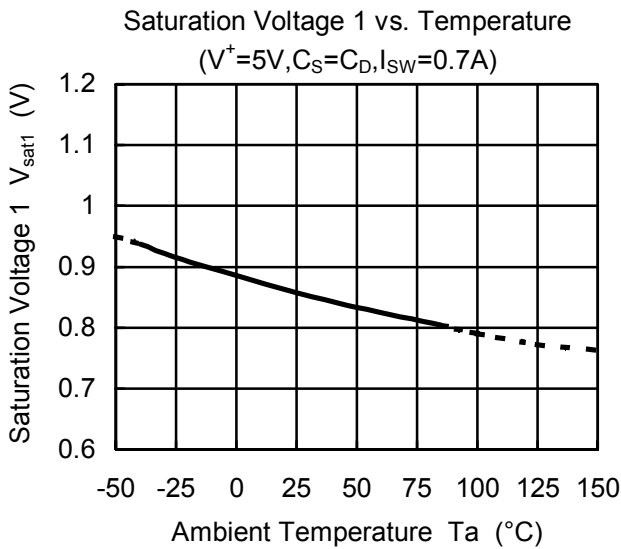
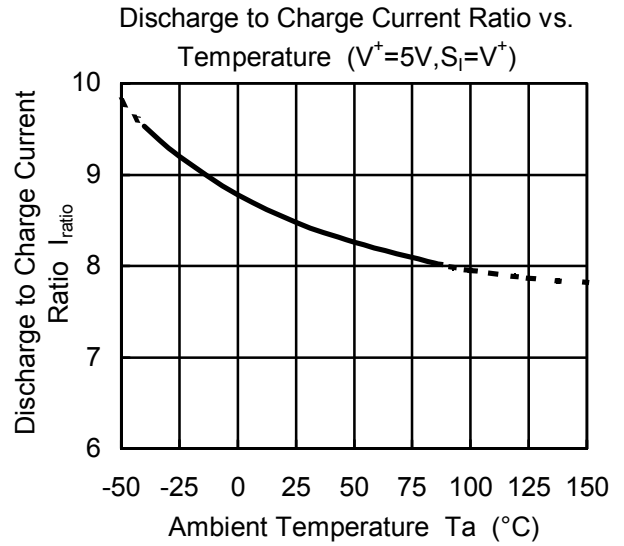
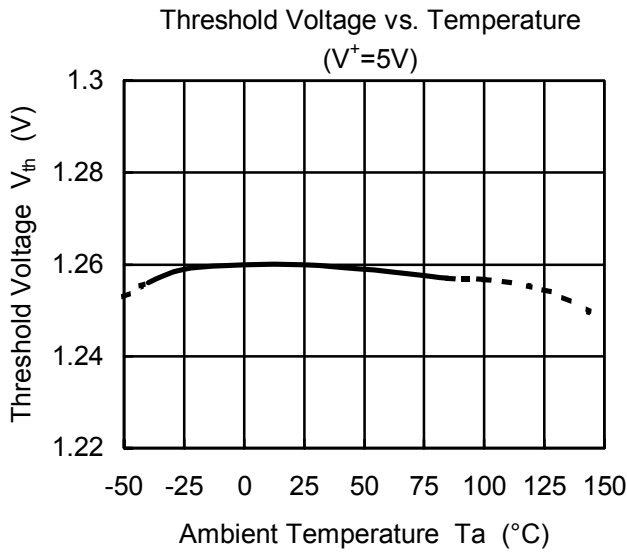

## ■ TYPICAL APPLICATIONS

### Step-Down Converter

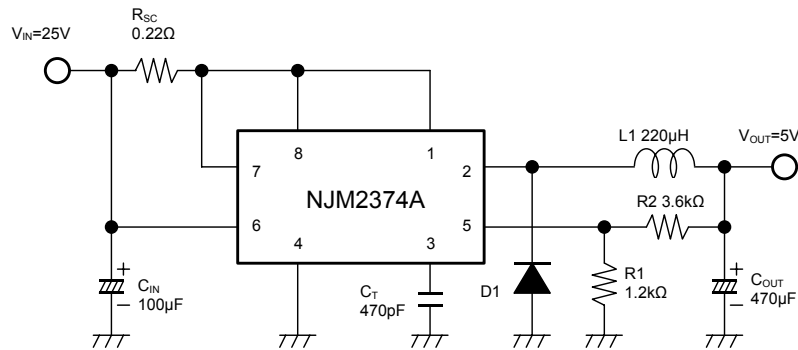

In the case of Step-Down Conversion with the internal power transistor, the Output Voltage must be set lower than 6V.

### Step-Up Converter

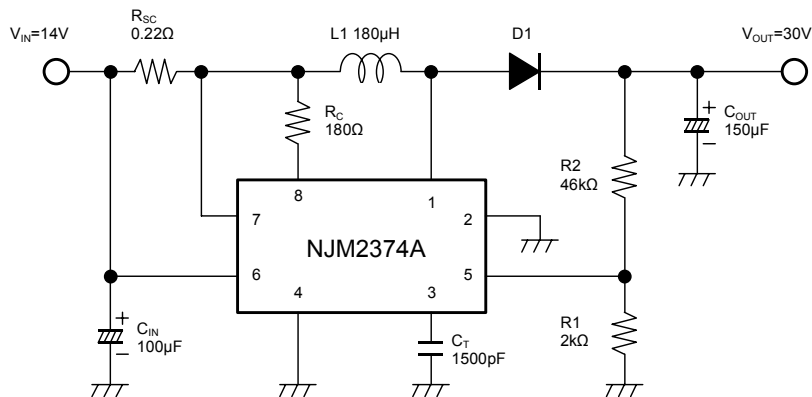

### Inverting Converter

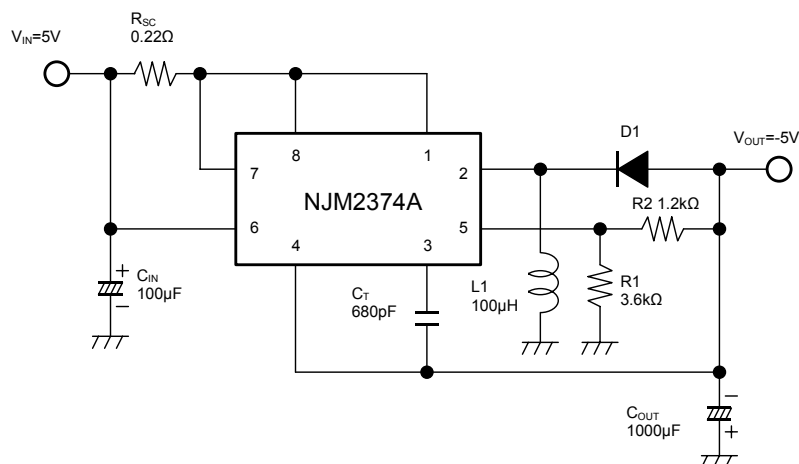

In the case of Inverting Conversion with the internal power transistor, the Output Voltage must be set lower than -6V.

D1 use to schottky diode.

In the case of SSOP packaging, the power dissipation should carefully be considered when designing this parts.

# NJM2374A

## Step-Down Converter (High Current)

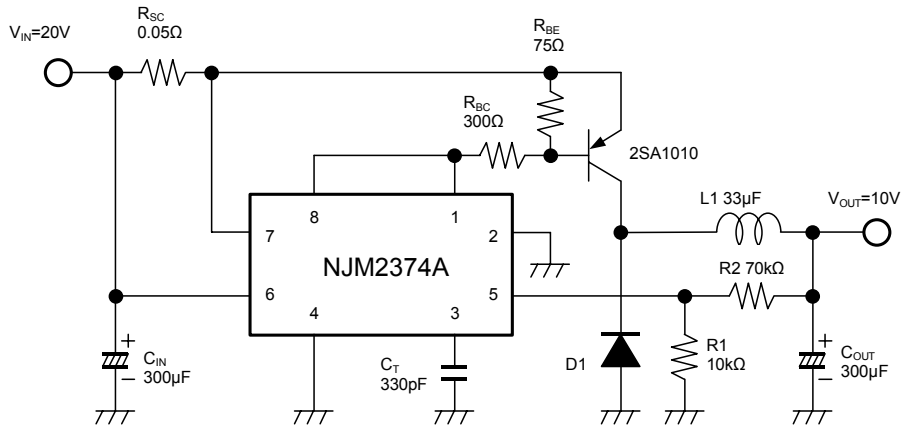

## Step-Up Converter (High Current)

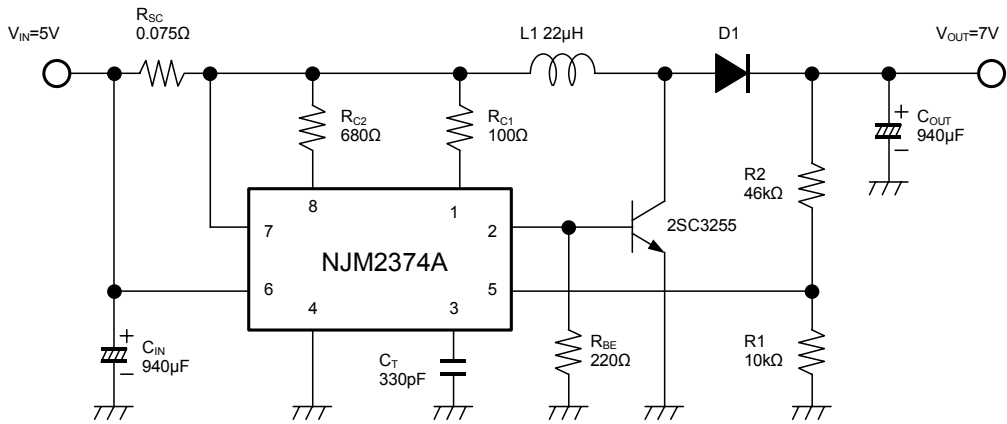

D1 use to schottky diode.

**[CAUTION]**

The specifications on this databook are only given for information, without any guarantee as regards either mistakes or omissions. The application circuits in this databook are described only to show representative usages of the product and not intended for the guarantee or permission of any right including the industrial rights.



## X-ON Electronics

Largest Supplier of Electrical and Electronic Components

*Click to view similar products for [Voltage Regulators - Switching Regulators](#) category:*

*Click to view products by [NJR](#) manufacturer:*

Other Similar products are found below :

[LX7186A](#) [622616F](#) [632259F](#) [FAN53610AUC33X](#) [MP2148GQD-33-P](#) [MP2374DS-LF-Z](#) [EN6310QA](#) [NCP81108MNTXG](#)  
[NCP81109BMNTXG](#) [L79M05TL-E](#) [FAN48610BUC45X](#) [R3](#) [LV5710GP-TE-L-H](#) [430464BB](#) [455605G](#) [AZ7500BMTR-E1](#) [MIC23156-](#)  
[0YML-T5](#) [MIC4930YFL-T5](#) [MP8763GLE-P](#) [KE177614](#) [418569H](#) [455596X](#) [511087D](#) [030908C](#) [063375FB](#) [067501FB](#) [099508GB](#)  
[EP5358LUA](#) [NCP81102MNTXG](#) [715715H](#) [FAN48611UC53X](#) [FAN53611AUC12X](#) [MAX809TTR](#) [MAX77596ETBC+T](#)  
[MAX77596ETBB+T](#) [MAX16905AUE/V+](#) [NCP6332CMTAATBG](#) [NCV890203MWTXG](#) [LX7176A](#) [ISL8018IRAJZ](#) [MP2162AGQH-Z](#)  
[MAX17544ATP+T](#) [EN6360QI](#) [MCP1623T-IMC](#) [MCP1642B-18IMC](#) [MCP1642BT-30I/MS](#) [MCP1642D-50IMC](#) [MCP1642D-50IMS](#)  
[MCP1642D-ADJIMC](#) [MC34063LBBGEVB](#)