

SENSITRON SEMICONDUCTOR

1N5550/US thru 1N5554/US

3A STANDARD RECOVERY
RECTIFIERS

TECHNICAL DATA
DATA SHEET 126, REV G.1

AVAILABLE AS
1N, JAN, JANTX, JANTXV
JANS
JAN EQUIVALENT*
SJ*, SX*, SV*, SS*

Fast Recovery Rectifiers

Qualified per MIL-PRF-19500/420

DESCRIPTION:

This voidless hermetically sealed standard recovery rectifier diode series is military qualified per MIL-PRF-19500/420 and is targeted for space, commercial and military aircraft, military vehicles, shipboard markets and all high reliability applications.

FEATURES / BENEFITS:

- ✓ Hermetic, non-cavity glass package
- ✓ Category I Metallurgically bonded
- ✓ All parts are 100% hot solder dipped
- ✓ JAN/ JANTX/ JANTXV available per MIL-PRF-19500/420
- ✓ "JANS Plus" removes atypical/out of family V_F

ELECTRICAL CHARACTERISTICS

MAX. RATINGS / ELECTRICAL CHARACTERISTICS All ratings are at $T_A = 25^\circ\text{C}$ unless otherwise specified.

RATING	CONDITIONS	MIN	TYP	MAX	UNIT
Peak Inverse Voltage (PIV) 1N5550 1N5551 1N5552 1N5553 1N5554	-	-	-	200 400 600 800 1000	Vdc
Average DC Output Current (I_o)	$T_A = +55^\circ\text{C}$	-	-	3.0	Amps
Peak Single Cycle Surge Current (I_{fsm})	$t_p = 8.3$ ms Single Half Cycle Sine Wave, Superimposed On Rated Load	-	-	100	Amps(pk)
Operating and Storage Temp. (T_{op} & T_{sto})	-	-65	-	+175	$^\circ\text{C}$
Maximum Forward Voltage (V_f) 1N5550 1N5551 1N5552 1N5553 1N5554	$I_f = 9.0\text{A}$ (300 μsec pulse, duty cycle < 2%)	-	-	1.2 1.2 1.2 1.3 1.3	Volts

SENSITRON SEMICONDUCTOR

1N5550/US thru 1N5554/US

3A STANDARD RECOVERY
RECTIFIERS

TECHNICAL DATA
DATA SHEET 126, REV G.1

RATING	CONDITIONS	MIN	TYP	MAX	UNIT
Maximum Instantaneous Reverse Current At Rated (PIV)	$T_A = 25^\circ\text{C}$ $T_A = 100^\circ\text{C}$	-	-	1.0 60	μAmps
Reverse Recovery Time (t_{rr})	$I_f = 0.5\text{A}$, $I_r = 1.0\text{A}$, $I_{rr} = 0.25\text{A}$	-	-	2000	nsec
Thermal Resistance (θ_{JL})	Junction to Lead $d = 0.375''$			22	$^\circ\text{C/W}$
Thermal Resistance (θ_{JEC})	Junction to Endcap	-	-	6.5	$^\circ\text{C/W}$

*Sensitron **space equivalent diodes** are manufactured and screened to MIL-PRF-19500 flow and guidelines starting from wafer fabrication through assembly and testing using our internal specification.

GRAPHS:

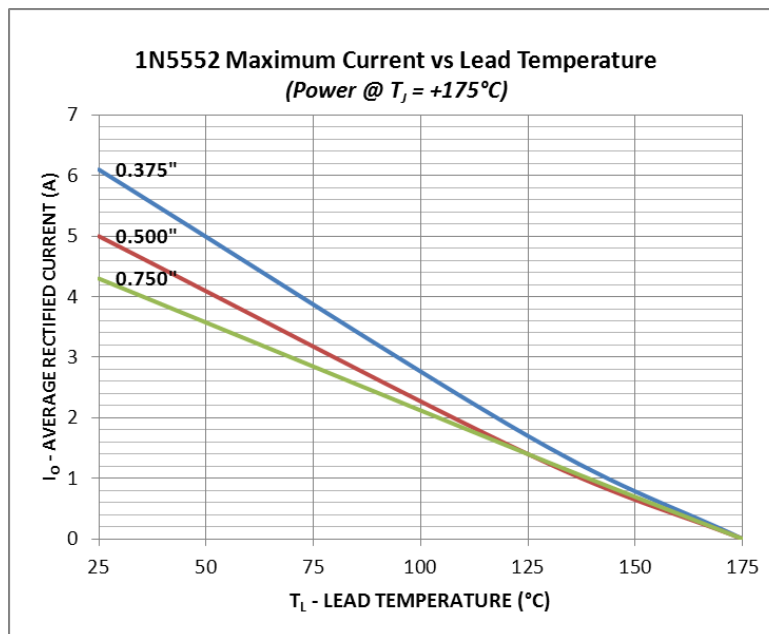

SENSITRON SEMICONDUCTOR

1N5550/US thru 1N5554/US

3A STANDARD RECOVERY
RECTIFIERS

TECHNICAL DATA
DATA SHEET 126, REV G.1

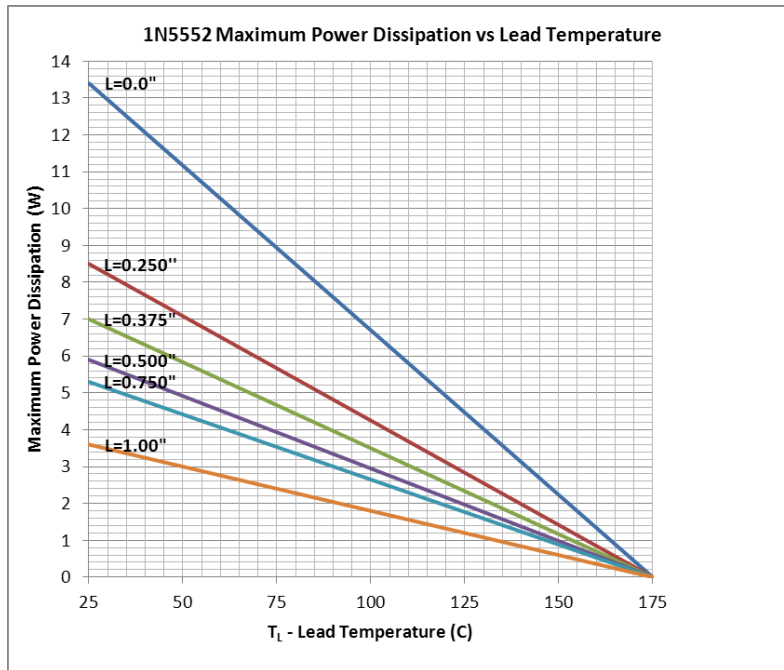

PACKAGE DIMENSIONS (inches/mm)

AXIAL (PKG 301)

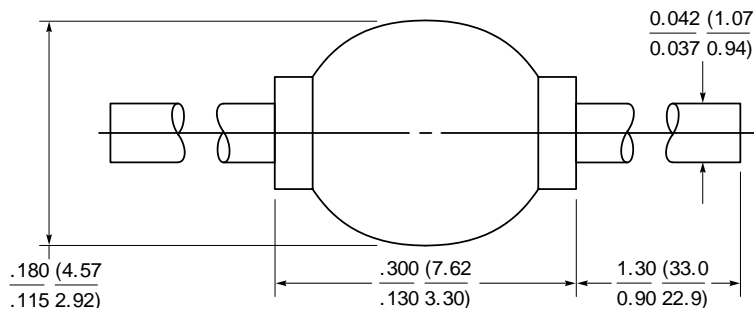

Note: The cathode side is marked with a dark colored band on one side of the diode body.

SENSITRON SEMICONDUCTOR

1N5550/US thru 1N5554/US

3A STANDARD RECOVERY
RECTIFIERS

TECHNICAL DATA
DATA SHEET 126, REV G.1

MELF (Add "US" to part number)

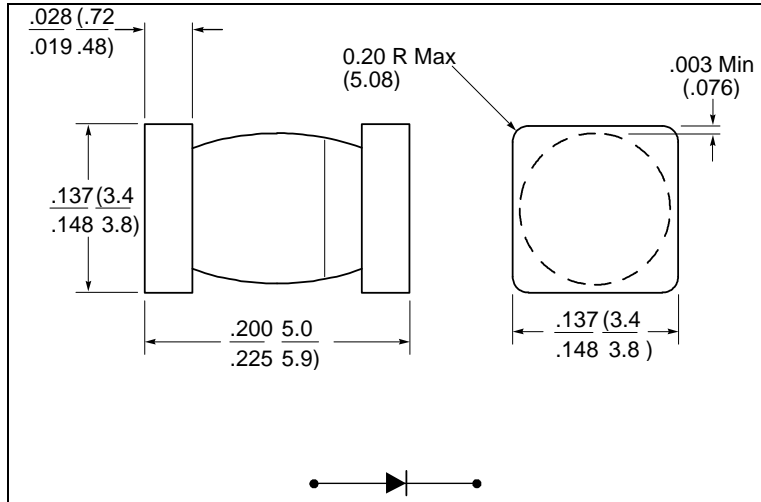

MELF-B

Note: The cathode side is marked on body with a dark band.

PART ORDERING INFORMATION

The following part numbers can be screened and tested to the military screening flow. The parts are marked in accordance with the testing performed, example:

Sensitron Screening Level	*Part Number-- Leaded Package (example for 1N5550)	*Part Number-- Surface Mount Package (example for 1N5550US)
1N	1N5550	1N5550US
JAN	JAN1N5550	JAN1N5550US
JANTX	JANTX1N5550	JANTX1N5550US
JANTXV	JANTXV1N5550	JANTXV1N5550US
SJ	SJ5550	SJ5550US
SX	SX5550	SX5550US
SV	SV5550	SV5550US
JANS	JANS1N5550	JANS1N5550US
SS	SS5550	SS5550US

DISCLAIMER:

- 1- The information given herein, including the specifications and dimensions, is subject to change without prior notice to improve product characteristics. Before ordering, purchasers are advised to contact the Sensitron Semiconductor sales department for the latest version of the datasheet(s).
- 2- In cases where extremely high reliability is required (such as use in nuclear power control, aerospace and aviation, traffic equipment, medical equipment, and safety equipment), safety should be ensured by using semiconductor devices that feature assured safety or by means of users' fail-safe precautions or other arrangement.
- 3- In no event shall Sensitron Semiconductor be liable for any damages that may result from an accident or any other cause during operation of the user's units according to the datasheet(s). Sensitron Semiconductor assumes no responsibility for any intellectual property claims or any other problems that may result from applications of information, products or circuits described in the datasheets.
- 4- In no event shall Sensitron Semiconductor be liable for any failure in a semiconductor device or any secondary damage resulting from use at a value exceeding the absolute maximum rating.
- 5- No license is granted by the datasheet(s) under any patents or other rights of any third party or Sensitron Semiconductor.
- 6- The datasheet(s) may not be reproduced or duplicated, in any form, in whole or part, without the expressed written permission of Sensitron Semiconductor.
- 7- The products (technologies) described in the datasheet(s) are not to be provided to any party whose purpose in their application will hinder maintenance of international peace and safety nor are they to be applied to that purpose by their direct purchasers or any third party. When exporting these products (technologies), the necessary procedures are to be taken in accordance with related laws and regulations.

X-ON Electronics

Largest Supplier of Electrical and Electronic Components

Click to view similar products for [Rectifiers](#) category:

Click to view products by [Semtech](#) manufacturer:

Other Similar products are found below :

[D91A](#) [DA24F4100L](#) [DD89N1600K-A](#) [DD89N16K-K](#) [RL252-TP](#) [DLA11C-TR-E](#) [DSA17G](#) [1N4005-TR](#) [BAV199-TP](#) [UFS120Je3/TR13](#)
[JANS1N6640US](#) [VS-80-1293](#) [DD89N16K](#) [DD89N16K-A](#) [481235F](#) [DSP10G-TR-E](#) [RRE02VS6SGTR](#) [067907F](#) [MS306](#) [ND104N08K](#)
[SPA2003-B-D-A01](#) [VS-80-6193](#) [VS-66-9903](#) [VGF0136AB](#) [US2JFL-TP](#) [UFS105Je3/TR13](#) [A1N5404G-G](#) [ACGRA4007-HF](#) [ACGRB207-HF](#)
[RF301B2STL](#) [RF501B2STL](#) [UES1306](#) [UES1302](#) [BAV199E6433HTMA1](#) [ACGRC307-HF](#) [ACEFC304-HF](#) [JANTXV1N5660A](#) [UES1106](#)
[GS2K-LTP](#) [D126A45C](#) [D251N08B](#) [SCHJ22.5K](#) [SM100](#) [SCPA2](#) [SCH10000](#) [SDHD5K](#) [STTH20P035FP](#) [VS-8EWS12S-M3](#) [VS-](#)
[12FL100S10](#) [ACGRA4001-HF](#)