



ELECTRONICS, INC.
 44 FARRAND STREET
 BLOOMFIELD, NJ 07003
 (973) 748-5089

NTE5600 thru NTE5607 TRIAC, 4 Amp

Description:

The NTE5600 through NTE5607 TRIACs are designed primarily for full-wave AC control applications such as light dimmers, motor controls, heating controls and power supplies; or wherever full-wave silicon gate controlled solid-state devices are needed. TRIAC type thyristors switch from a blocking to a conducting state for either polarity of applied anode voltage with positive or negative gate triggering.

Features:

- 2 Mode Gate Triggering
- Blocking Voltages to 600V
- All Diffused and Glass Passivated Junctions for Greater Parameters Uniformity and Stability

Absolute Maximum Ratings:

Repetitive Peak Off-State Voltage ($T_C = +110^\circ\text{C}$, Note 1), V_{DRM}	
NTE5600	25V
NTE5601	50V
NTE5602	100V
NTE5603	200V
NTE5604	300V
NTE5605	400V
NTE5606	500V
NTE5607	600V
RMS On-State Current ($T_C = +85^\circ\text{C}$), $I_{\text{T(RMS)}}$	
4A	
Peak Surge Current (One Full Cycle, 60Hz, $T_J = -40^\circ$ to $+110^\circ\text{C}$), I_{TSM}	
30A	
Circuit Fusing ($t = 8.3\text{ms}$), I^2t	
3.7A ² s	
Peak Gate Power, P_{GM}	
10W	
Average Gate Power, $P_{\text{G(AV)}}$	
0.5W	
Peak Gate Voltage, V_{GM}	
5V	
Operating Junction Temperature Range, T_J	
-40° to $+110^\circ\text{C}$	
Storage Temperature Range, T_{stg}	
-40° to $+150^\circ\text{C}$	
Thermal Resistance, Junction-to-Case, R_{thJC}	
3.5°C/W	
Thermal Resistance, Junction-to-Ambient, R_{thJA}	
75°C/W	
Mounting Torque (6-32 Screw, Note 2)	
8 in. lb.	

Note 1. Ratings apply for open gate conditions. Thyristor devices shall not be tested with a constant current source for blocking capability such that the voltage applied exceeds the rated blocking voltage.

Note 2. Torque rating applies with the use of a compression washer. Mounting torque in excess of 8 in. lb. does not appreciably lower case-to-sink thermal resistance. MT_2 and heatsink contact pad are common.

Electrical Characteristics: ($T_C = +25^\circ\text{C}$ unless otherwise specified)

Parameter	Symbol	Test Conditions	Min	Typ	Max	Unit
Peak Forward or Reverse Blocking Current	I_{DRM} , I_{RRM}	Rated V_{DRM} or V_{RRM} , Gate Open, $T_J = +25^\circ\text{C}$	-	-	10	μA
		Rated V_{DRM} or V_{RRM} , Gate Open, $T_J = +110^\circ\text{C}$	-	-	2	mA
On-State Voltage (Either Direction)	V_{TM}	$I_{TM} = 6\text{A Peak}$	-	-	2	V
Peak Gate Trigger Voltage MT ₂ (+), G (+); MT ₂ (-), G (-) MT ₂ (+), G (-); MT ₂ (-), G (+)	V_{GT}	Main Terminal Voltage = 12V, $R_L = 100\Omega$, $T_J = -40^\circ\text{C}$	-	1.4	2.5	V
Peak Gate Trigger Voltage MT ₂ (+), G (+); MT ₂ (-), G (-) MT ₂ (+), G (-); MT ₂ (-), G (+)	V_{GT}	Main Terminal Voltage = Rated V_{DRM} , $R_L = 10\text{k}\Omega$, $T_J = +110^\circ\text{C}$	0.2	-	-	V
Holding Current (Either Direction)	I_H	Main Terminal Voltage = 12V, Gate Open, $T_J = -40^\circ\text{C}$, Initiating Current = 1A	-	-	70	mA
		Main Terminal Voltage = 12V, Gate Open, $T_J = +25^\circ\text{C}$	-	-	30	mA
Turn-On Time (Either Direction)	t_{on}	$I_{TM} = 14\text{A}$, $I_{GT} = 100\text{mA}$	-	1.5	-	μs
Blocking Voltage Application Rate at Commutation	dv/dt	Rated V_{DRM} , Gate Open, $T_J = +85^\circ\text{C}$	-	5	-	V/ μs
Gate Trigger Current Quads I & III	I_{GT}	Main Terminal Voltage = 12V, $R_L = 100\Omega$, $T_J = +25^\circ\text{C}$	-	-	30	mA
		Main Terminal Voltage = 12V, $R_L = 100\Omega$, $T_J = -40^\circ\text{C}$	-	-	60	mA

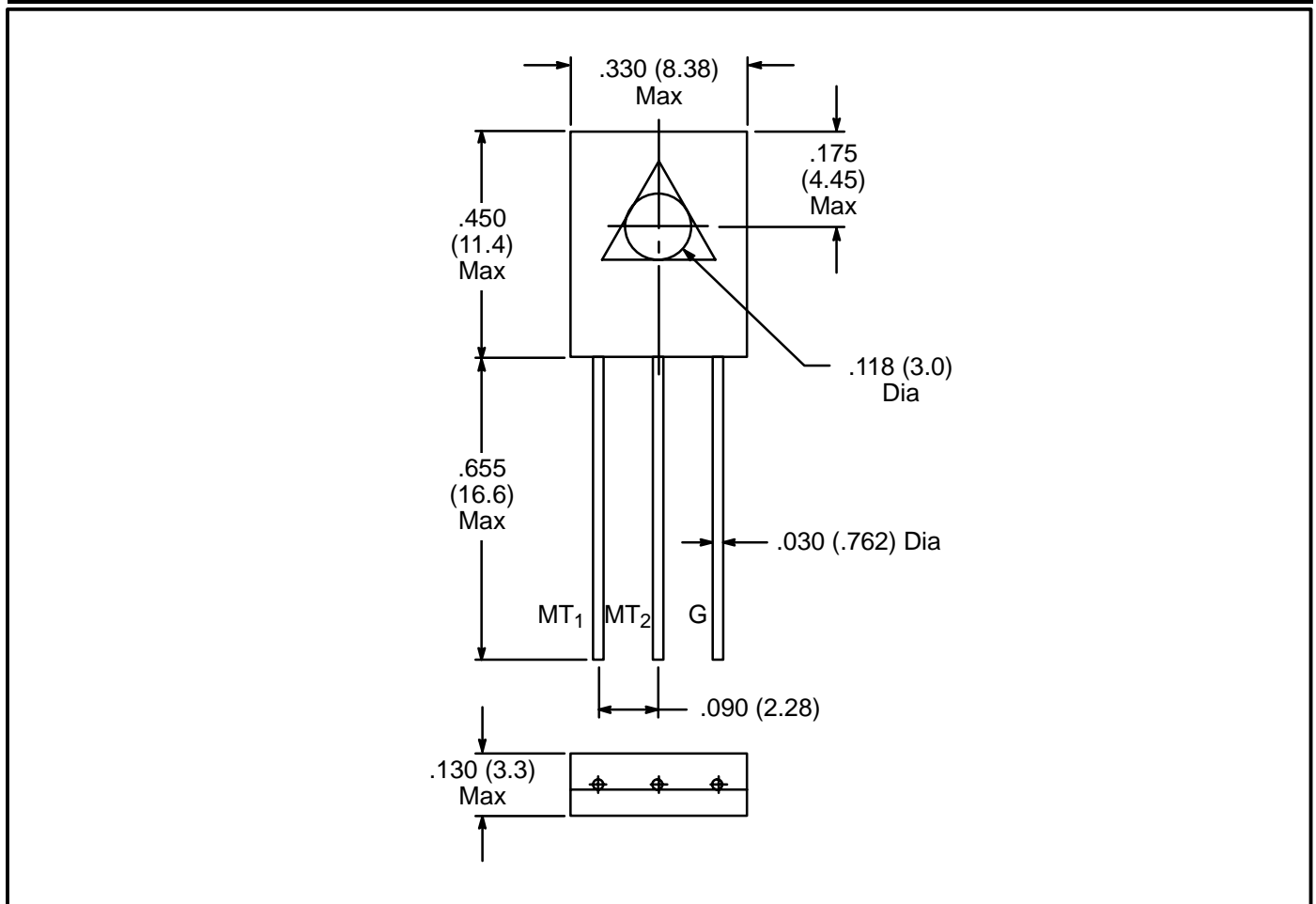

X-ON Electronics

Largest Supplier of Electrical and Electronic Components

Click to view similar products for [Triacs](#) category:

Click to view products by [NTE](#) manufacturer:

Other Similar products are found below :

[ACST435-8B](#) [LIC01-215B-TR](#) [T2035H-6G](#) [BT137-600-0Q](#) [Z0410NF 1AA2](#) [098128C](#) [620675E](#) [T1610-600G-TR](#) [Z0409MF0AA2](#)
[Z0109NA 2AL2](#) [ACS108-8SA-AP](#) [ACS108-8SN-TR](#) [ACST1635T-8FP](#) [BCR16PM-12LG#B00](#) [BCR20RM-30LA#B00](#) [T1205-600G-TR](#)
[CMA60MT1600NHR](#) [NTE5611](#) [NTE5612](#) [NTE5613](#) [NTE5621](#) [NTE5623](#) [NTE5629](#) [NTE5638-08](#) [NTE5688](#) [NTE5689](#) [NTE5690](#) [T1235T-](#)
[8I](#) [BTA312-600CT.127](#) [T1210T-8G-TR](#) [T1210T-8G](#) [BT136S-600E,118](#) [BT137B-800G,118](#) [Z0109NN0,135](#) [MAC4DLM-1G](#) [BT137-](#)
[600E,127](#) [BT137X-600D](#) [BT148W-600R,115](#) [BT258-500R,127](#) [BTA08-800BW3G](#) [BTA140-800,127](#) [BTA30-600CW3G](#) [BTA30-600CW3G](#)
[BTB08-800BW3G](#) [BTB16-600CW3G](#) [BTB16-600CW3G](#) [Z0405M-0AA2](#) [Z0410MF0AA2](#) [Z0109MN,135](#) [T825T-6I](#)