



ELECTRONICS, INC.
 44 FARRAND STREET
 BLOOMFIELD, NJ 07003
 (973) 748-5089

NTE5650 thru NTE5653 TRIAC – 100V_{RM}, 2.5A

Description:

The NTE5650 through NTE5653 sensitive gate TRIACs are designed to be driven directly with IC and MOS devices. These devices features a void-free glass passivated chip and are hermetically sealed in TO-5 outline cans.

The NTE5650 through NTE5653 are bi-directional triode thyristors and may be switched from off-state to conduction for either polarity of applied voltage with positive or negative gate-trigger current and are designed for control applications in lighting, heating, cooling and static switching relays.

Absolute Maximum Ratings:

Repetitive Peak Off-State Voltage ($T_J = +90^\circ\text{C}$, Gate Open, Note 1), V_{DROM}

NTE5650	100V
NTE5651	200V
NTE5652	400V
NTE5653	600V

RMS On-State Current ($T_C = +75^\circ\text{C}$ and Conduction Angle of 360°), $I_{T(RMS)}$ 3A

Peak Surge (Non-Repetitive) On-State Current (One-Cycle at 50Hz or 60Hz), I_{TSM} 30A

Peak Gate-Trigger Current (3 μ sec, Max.), I_{GTM} 1A

Peak Gate-Power Dissipation ($I_{GT} \leq I_{GTM}$ for 3 μ sec. Max.), P_{GM} 20W

Average Gate-Power Dissipation, $P_{G(AV)}$ 0.2W

Operating Temperature Range (T_C), T_{opr} -40° to $+90^\circ\text{C}$

Storage Temperature Range, T_{stg} -40° to $+150^\circ\text{C}$

Typical Thermal Resistance, Junction-to-Case, R_{thJC} 4°C/W

Note 1. All values apply in either direction.

Electrical Characteristics: (At Maximum Ratings & Specified Case Temperature)

Parameter	Symbol	Test Conditions	Min	Typ	Max	Unit
Peak Off-State Current	I_{DROM}	$T_J = +90^\circ\text{C}$, $V_{DROM} = \text{Max Rating}$, Gate Open, Note 1	-	-	0.75	mA
Maximum On-State Voltage	V_{TM}	$T_C = +25^\circ\text{C}$, $i_T = 5\text{A}$ (Peak), Note 1	-	-	1.85	V
DC Holding Current	I_{HO}	$T_C = +25^\circ\text{C}$, Gate Open	-	-	5	mA
Critical Rate-of-Rise of Off-State Voltage	Critical dv/dt	$T_C = +90^\circ\text{C}$, $v_D = V_{DROM}$, Gate Open, Note 1	-	3	-	V/ μ s
DC Gate-Trigger Current MT ₂ (+) Gate (+), MT ₂ (-) Gate (-) MT ₂ (+) Gate (-), MT ₂ (-) Gate (+)	I_{GT}	$T_C = +25^\circ\text{C}$, $v_D = 6\text{V}$, $R_L = 39\Omega$	-	-	3	mA

Note 1. All values apply in either direction.

Electrical Characteristics (Cont'd): (At Maximum Ratings & Specified Case Temperature)

Parameter	Symbol	Test Conditions	Min	Typ	Max	Unit
DC Gate Trigger Voltage	V_{GT}	$T_C = +25^\circ\text{C}$, $v_D = 6\text{V}$, $R_L = 39\Omega$	–	–	2.2	V
Gate-Controlled Turn-On Time	t_{gt}	$T_C = +25^\circ\text{C}$, $v_D = V_{DROM}$, $I_{GT} = 80\text{mA}$, $t_r = 0.1\mu\text{s}$, $i_T = 10\text{A}$ (Peak)	–	2.2	–	μs
Fusing Current (For TRIAC Protection)	I^2t	$T = 1.25$ to 10ms	–	–	3	A^2s

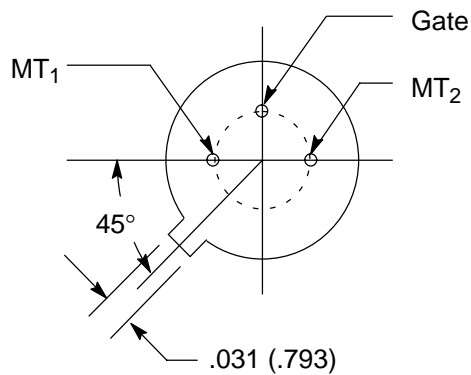
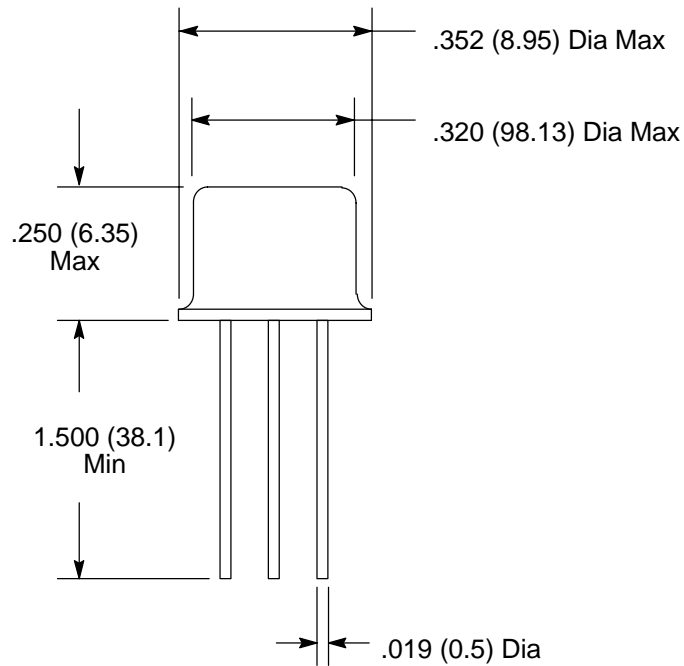

TO5

X-ON Electronics

Largest Supplier of Electrical and Electronic Components

Click to view similar products for [Triacs](#) category:

Click to view products by [NTE](#) manufacturer:

Other Similar products are found below :

[ACST435-8B](#) [LIC01-215B-TR](#) [T2035H-6G](#) [BT137-600-0Q](#) [Z0410NF 1AA2](#) [098128C](#) [620675E](#) [T1610-600G-TR](#) [Z0409MF0AA2](#)
[Z0109NA 2AL2](#) [ACS108-8SA-AP](#) [ACS108-8SN-TR](#) [ACST1635T-8FP](#) [BCR16PM-12LG#B00](#) [BCR20RM-30LA#B00](#) [T1205-600G-TR](#)
[CMA60MT1600NHR](#) [NTE5611](#) [NTE5612](#) [NTE5613](#) [NTE5621](#) [NTE5623](#) [NTE5629](#) [NTE5638-08](#) [NTE5688](#) [NTE5689](#) [NTE5690](#) [T1235T-](#)
[8I](#) [BTA312-600CT.127](#) [T1210T-8G-TR](#) [T1210T-8G](#) [BT136S-600E,118](#) [BT137B-800G,118](#) [Z0109NN0,135](#) [MAC4DLM-1G](#) [BT137-](#)
[600E,127](#) [BT137X-600D](#) [BT148W-600R,115](#) [BT258-500R,127](#) [BTA08-800BW3G](#) [BTA140-800,127](#) [BTA30-600CW3G](#) [BTA30-600CW3G](#)
[BTB08-800BW3G](#) [BTB16-600CW3G](#) [BTB16-600CW3G](#) [Z0405M-0AA2](#) [Z0410MF0AA2](#) [Z0109MN,135](#) [T825T-6I](#)