

FEATURES

- **IMPROVED POWER RATING** (HIGHER THAN NTR SERIES)
- **PRECISE TOLERANCE AND TEMPERATURE COEFFICIENT**
- **EIA STANDARD CASE SIZES** (0402 ~ 2512)
- **LOW NOISE, THIN FILM (NiCr) CONSTRUCTION**
- **REFLOW SOLDERABLE (Pb FREE TERMINATION FINISH)**

RoHS Compliant
includes all homogeneous materials

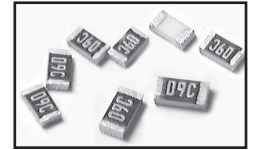

*See Part Number System for Details

Type	EIA Size	Power Rating at 70°C	Max.*1 Working Voltage	Max.*2 Overload Voltage	Resistance Tolerance (Code)	Temperature Coefficient (ppm/°C)	Resistance Range (Ω)	Resistance Values
NTRH04	0402	1/10 (0.100)W	50V	100V	±0.01% (T), ±0.05% (A), ±0.1% (B)	±2 (X), ±3 (O)	49.9 ~ 4.99KΩ	E24 & E-96
					±0.01% (T), ±0.05% (A), ±0.1% (B), ±0.25 (C), ±0.5 (D), ±1% (F)	±5 (S)	49.9 ~ 4.99KΩ	
					±0.01% (T), ±0.05% (A)	±10 (B) ±15 (N)	49.9 ~ 12KΩ	
					±0.1% (B), ±0.25 (C), ±0.5 (D), ±1% (F)	±10 (B)	49.9 ~ 60KΩ	
					±0.1% (B), ±0.25 (C), ±0.5 (D), ±1% (F)	±15 (N)	49.9 ~ 69.8KΩ	
					±0.05% (A)	±25 (C) ±50 (D)	49.9 ~ 12KΩ	
					±0.1% (B)		10 ~ 255KΩ	
±0.25 (C), ±0.5 (D), ±1% (F)	4.7 ~ 255KΩ							
NTRH06	0603	1/10 (0.100)W	75V	150V	±0.01% (T), ±0.05% (A), ±0.1% (B)	±2 (X), ±3 (O)	24.9 ~ 15KΩ	
					±0.01% (T), ±0.05% (A), ±0.1% (B), ±0.25 (C), ±0.5 (D), ±1% (F)	±5 (S)	24.9 ~ 15KΩ	
					±0.01% (T)	±10 (B) ±15 (N) ±25 (C) ±50 (D)	24.9 ~ 100KΩ	
					±0.05% (A)	±10 (B) ±15 (N)	4.7 ~ 332KΩ	
					±0.1% (B), ±0.25 (C), ±0.5 (D), ±1% (F)	±10 (B) ±15 (N)	4.7 ~ 332KΩ	
NTRH07		1/6 (0.166)W	100V	150V	± 0.05% (A), ±0.1% (B), ±0.25 (C), ±0.5 (D), ±1% (F)	±25 (C) ±50 (D)	10 ~ 332KΩ	
NTRH10	0805	1/8 (0.125)W	150V	300V	±0.01% (T), ±0.05% (A), ±0.1% (B)	±2 (X), ±3 (O)	24.9 ~ 30KΩ	
					±0.01% (T), ±0.05% (A), ±0.1% (B), ±0.25 (C), ±0.5 (D), ±1% (F)	±5 (S)	24.9 ~ 30KΩ	
					±0.01% (T)	±10 (B) ±15 (N) ±25 (C) ±50 (D)	24.9 ~ 200KΩ	
					±0.05% (A)	±10 (B) ±15 (N)	4.7 ~ 511KΩ	
					±0.1% (B), ±0.25 (C), ±0.5 (D), ±1% (F)	±10 (B) ±15 (N)	4.7 ~ 511KΩ	
					±0.1% (B)	±25 (C) ±50 (D)	4.7 ~ 1MΩ	
					±0.25 (C), ±0.5 (D), ±1% (F)	±25 (C) ±50 (D)	1.0 ~ 1MΩ	
NTRH11		1/4 (0.250)W			± 0.05% (A), ±0.1% (B), ±0.25 (C), ±0.5 (D), ±1% (F)	±25 (C) ±50 (D)	10 ~ 499KΩ	
NTRH12	1206	1/4 (0.250)W	200V	400V	±0.01% (T), ±0.05% (A), ±0.1% (B)	±2 (X), ±3 (O)	24.9 ~ 49.9KΩ	
					±0.01% (T), ±0.05% (A), ±0.1% (B), ±0.25 (C), ±0.5 (D), ±1% (F)	±5 (S)	24.9 ~ 49.9KΩ	
					±0.01% (T)	±10 (B) ±15 (N) ±25 (C) ±50 (D)	24.9 ~ 499KΩ	
					±0.05% (A), ±0.1% (B), ±0.25 (C), ±0.5 (D), ±1% (F)	±10 (B) ±15 (N) ±25 (C) ±50 (D)	4.7 ~ 1MΩ	
NTRH13		1/3 (0.333)W			± 0.05% (A), ±0.1% (B), ±0.25 (C), ±0.5 (D), ±1% (F)	±25 (C) ±50 (D)	10 ~ 1MΩ	

Continue on next page



Type	EIA Size	Power Rating at 70°C	Max.*1 Working Voltage	Max.*2 Overload Voltage	Resistance Tolerance (Code)	Temperature Coefficient (ppm/°C)	Resistance Range (Ω)	Resistance Values
NTRH15	1210	1/3 (0.333)W	200V	400V	±0.01% (T), ±0.05% (A), ±0.1% (B)	±2 (X), ±3 (O)	24.9 ~ 49.9KΩ	E24 & E-96
					±0.01% (T), ±0.05% (A), ±0.1% (B), ±0.25 (C), ±0.5 (D), ±1% (F)	±5 (S)	24.9 ~ 49.9KΩ	
					±0.01% (T)	±10 (B) ±15 (N)	24.9 ~ 499KΩ	
					±0.05% (A), ±0.1% (B), ±0.25 (C), ±0.5 (D), ±1% (F)	±25 (C) ±50 (D)	4.7 ~ 1MΩ	
NTRH20	2010	1/3 (0.333)W	200V	400V	±0.01% (T), ±0.05% (A), ±0.1% (B)	±2 (X), ±3 (O)	24.9 ~ 49.9KΩ	
					±0.01% (T), ±0.05% (A), ±0.1% (B), ±0.25 (C), ±0.5 (D), ±1% (F)	±5 (S)	24.9 ~ 49.9KΩ	
					±0.01% (T)	±10 (B) ±15 (N)	24.9 ~ 499KΩ	
					±0.05% (A), ±0.1% (B), ±0.25 (C), ±0.5 (D), ±1% (F)	±25 (C) ±50 (D)	4.7 ~ 1MΩ	
NTRH25	2512	3/4 (0.750)W	200V	400V	±0.01% (T)	±10 (B)	24.9 ~ 2KΩ	
					±0.05% (A), ±0.1% (B)	±15 (N)	4.7 ~ 2KΩ	
NTRH26	2512	1.0W	200V	400V	±0.25 (C), ±0.5 (D), ±1% (F)	±25 (C) ±50 (D)	1.0 ~ 2KΩ	
					0.1% (B)	±25 (C) ±50 (D)	4.7 ~ 100Ω	
					±0.25 (C), ±0.5 (D), ±1% (F)	±50 (D)	1.0 ~ 100Ω	

ENVIRONMENTAL CHARACTERISTICS

Item	Specification	Test Method
Standard Temperature Range: -55°C ~ +155°C (power derating above +70°C)		
Temperature Coefficient of Resistance	As specified	MIL-STD-202, Method 304 +25/-55/+25/+125/+25
Short Time Overload	ΔR ± 0.2%	JIS-C-5202-5.5 RCWV x 2.5 or Max Overloading Voltage for 5 Seconds
Dielectric Withstanding Voltage	As specified	MIL-STD-202F Method 301 Apply Max. Overload Voltage for 1 minute
Insulation Resistance	>9999MΩ	MIL-STD-202F Method 302 Apply 100Vdc for 1 minute
Thermal Shock	Tol ≤0.05%: ΔR ± 0.05% Tol >0.05%: ΔR ± 0.2%	MIL-STD-202F Method 107G -55°C ~ +150°C, 100 cycles
Load Life	ΔR ± 0.5%	MIL-STD-202F Method 108A RCWV +70°C, 1.5 hours ON, 0.5 hours OFF Total time 1,000 ~ 1,048 hours
Humidity (Steady State)	ΔR ± 0.5%	MIL-STD-202F Method 103B +40°C, 90% ~ 95% RH, RCWV 1.5 hours ON, 0.5 hours OFF Total time 1,000 ~ 1,048 hours
High Temperature Exposure	ΔR ± 0.5%	MIL-STD-202F Method 103B 1000 hours @ +155°C without load
Low Temperature Operation	ΔR ± 0.5%	JIS-C-502-7.1 1 hour @ -65°C followed by 45 minutes of RCWV
Bending Strength	Tol ≤0.05%: ΔR ± 0.05% Tol >0.05%: ΔR ± 0.1%	JIS-C-5202-6.1.4 Bending Amplitude 3mm for 10 seconds
Solderability	95% Minimum Coverage	MIL-STD-202F Method 208H 245°C ±5°C, 5 ±0.5 seconds
Resistance to Soldering Heat	Tol ≤0.05%: ΔR ± 0.05% Tol >0.05%: ΔR ± 0.1%	MIL-STD-202F Method 210E 260°C ±5°C for 10 ±1 seconds

PART NUMBER SYSTEM

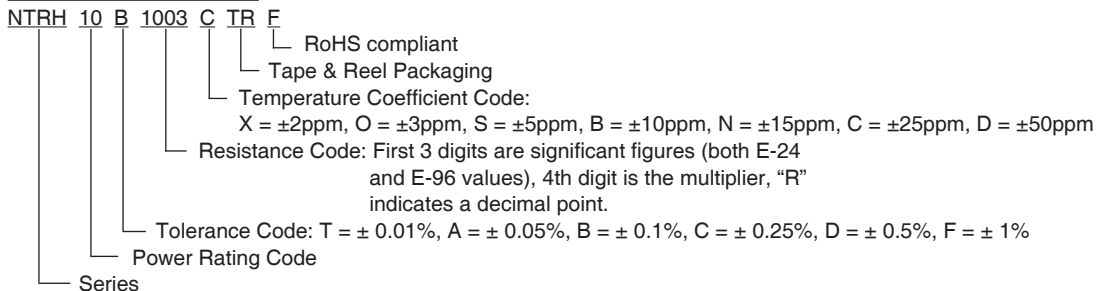

Note *1 - Maximum allowable continuous Working Voltage for all resistors is the lower of the two values:
 "Maximum Working Voltage" as specified above
 or

$$\sqrt{\text{Power rating (Watts)} \times \text{Resistance (Ohms)}}$$

Note *2 - Maximum Overload Voltage for all resistors is the lower of the two values:
 "Maximum Overload Voltage" as specified above
 or

$$2.5 \times \sqrt{\text{Power rating (Watts)} \times \text{Resistance (Ohms)}}$$

TYPICAL NOISE CHARACTERISTICS

Resistance Value (Ω)	Case Size		
	0603	0805	1206
4.7 ~ 9	-95dB	-95dB	-95dB
10 ~ 49	-85dB	-85dB	-85dB
50 ~ 99	-85dB	-85dB	-85dB
100 ~ 4.99K	-100dB	-100dB	-105dB
5K ~ 19.9K	-100dB	-100dB	-100dB
20K ~ 1M	-90dB	-100dB	-100dB

Power Derating Curve: For operation above 70°C, power rating must be derated according to the following chart:

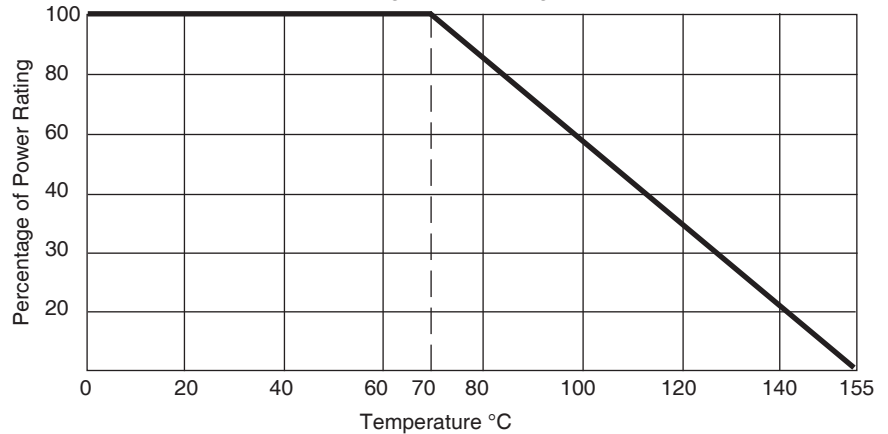

STANDARD E-24, E-96 VALUES AND 0603 RESISTANCE CODES

E-24 Value	E-96							
	Value Code		Value Code		Value Code		Value Code	
100	100	01	102	02	105	03	107	04
110	110	05	113	06	115	07	118	08
120	121	09	124	10	127	11	130	12
130	133	13	137	14	140	15	143	16
150	147	17	150	18	154	19	158	20
160	162	21	165	22	169	23	174	24
180	178	25	182	26	187	27	191	28
200	196	29	200	30	205	31	210	32
220	215	33	221	34	226	35	232	36
240	237	37	243	38	249	39	255	40
270	261	41	267	42	274	43	280	44
300	287	45	294	46	301	47	309	48
330	316	49	324	50	332	51	340	52
360	348	53	357	54	365	55	374	56
390	383	57	392	58	402	59	412	60
430	422	61	432	62	442	63	453	64
470	464	65	475	66	487	67	499	68
510	511	69	523	70	536	71	549	72
560	562	73	576	74	590	75	604	76
620	619	77	634	78	649	79	665	80
680	681	81	698	82	715	83	732	84
750	750	85	768	86	787	87	806	88
820	825	89	845	90	866	91	887	92
910	909	93	931	94	953	95	976	96

MULTIPLIER CODES

Code	A	B, b	C	D, d	E	F	G	H	X	Y	Z
Multiplier	10 ⁰	10 ¹	10 ²	10 ³	10 ⁴	10 ⁵	10 ⁶	10 ⁷	10 ⁻¹	10 ⁻²	10 ⁻³

- No marking for 0402 case size.
- Marking for 0603 case size is a three character code. The code** includes two characters to denote the value (based on 0603 Resistance Codes Table and a third character that denotes the value multiplier (see multiplier codes table).

CODING FORMULA

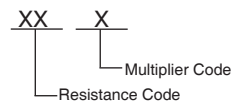

MARKING EXAMPLES

10Ω = 01X
 7.5k Ω = 85B
 150k Ω = 18D
 1 MegΩ = 01E

- The 0805 and 1206 case sizes parts use the standard four character marking method as shown in the examples below.
- E-24 and E-96 series - ±0.5% (D), ±0.25% (C), ±0.1% (B) tolerances
 4 DIGIT MARKING SYSTEM - First 3 digits are the significant figures, the 4th digit is the multiplier. "R" = decimal point.

Examples: 0R10 = 0.10 ohms, 1R00 = 1.0 ohms, 22R1=22.1 ohms, 3320= 332 ohms, 4751=4.75K ohms, 1132=11.3K ohms, 6493=649K ohms



DIMENSIONS (mm)

Type	EIA Size	L	W	H	T	t
NTRH04	0402	1.00 ± 0.05	0.50 ± 0.05	0.30 ± 0.05	0.20 ± 0.10	0.20 ± 0.10
NTRH06/07	0603	1.55 ± 0.10	0.80 ± 0.10	0.45 ± 0.10	0.30 ± 0.20	0.30 ± 0.20
NTRH10/11	0805	2.0 ± 0.15	1.25 ± 0.15	0.55 ± 0.10	0.30 ± 0.20	0.40 ± 0.25
NTRH12/13	1206	3.05 ± 0.10	1.55 ± 0.10	0.55 ± 0.10	0.42 ± 0.20	0.35 ± 0.25
NTRH15	1210	3.10 ± 0.15	2.40 ± 0.15	0.55 ± 0.10	0.40 ± 0.20	0.55 ± 0.25
NTRH20	2010	4.90 ± 0.15	2.40 ± 0.15	0.55 ± 0.10	0.60 ± 0.30	0.50 ± 0.25
NTRH25/26	2512	6.30 ± 0.15	3.10 ± 0.15	0.55 ± 0.10	0.60 ± 0.30	0.50 ± 0.25

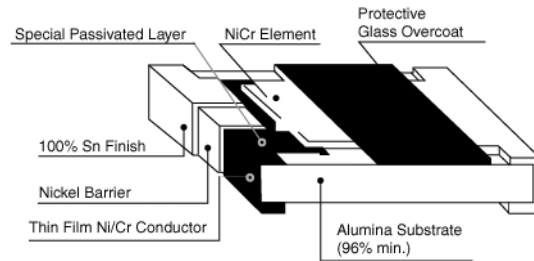
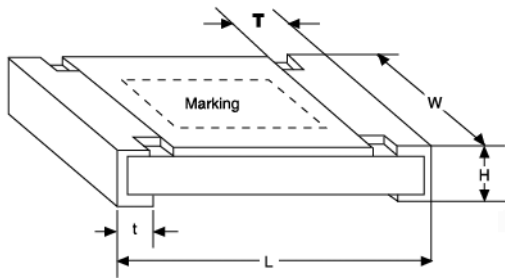

TAPING SPECIFICATIONS

(1) Availability

Type	EIA Size	Carrier Tape		Qty per Reel (pcs)
		Material	Width (mm)	
NTRH04	0402	Paper	8	10,000
NTRH06/07	0603			
NTRH10/11	0805			
NTRH12/13	1206			
NTRH15	1210	Plastic	12	4,000
NTRH20	2010			
NTRH25/26	2512			

(2) PAPER TAPE DIMENSIONS (mm)

Type	EIA Size	A ± 0.05	B ± 0.05	D	E	F	P ₀	P ₁	P ₂	W	T
NTRH04	0402	0.70	1.16	1.55 ± 0.05	1.75 ± 0.05	3.50 ± 0.05	4.0 ± 0.10	2.0 ± 0.05	2.0 ± 0.05	8.0 ± 0.1	0.40 ± 0.03
NTRH06/07	0603	1.10	1.90					0.60 ± 0.03			
NTRH10/11	0805	1.60	2.37					0.75 ± 0.05			
NTRH12/13	1206	2.00	3.55	1.60 ± 0.10				4.0 ± 0.05			
NTRH15	1210	2.75	3.40								

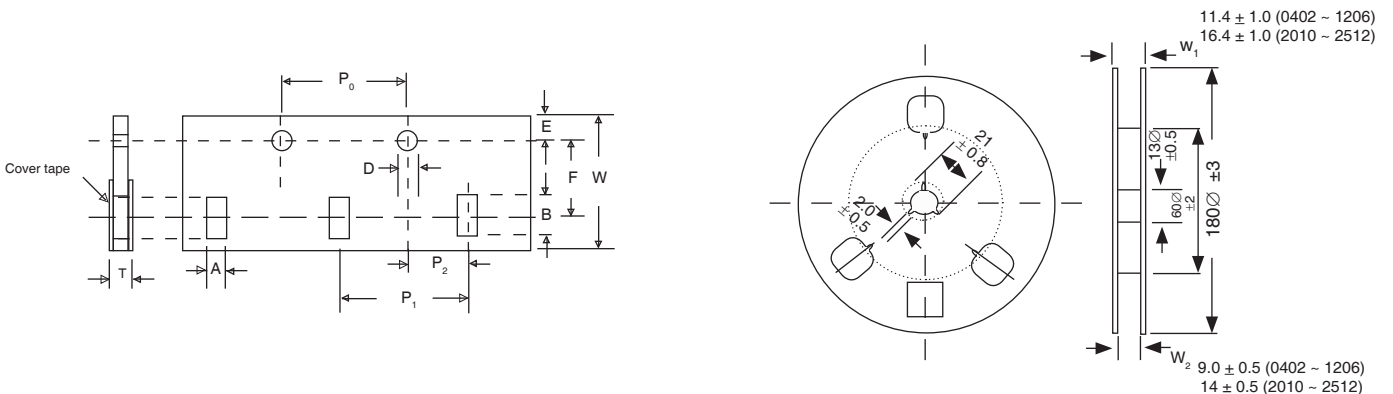

(2) PLASTIC TAPE DIMENSIONS (mm)

Type	EIA Size	A ± 0.10	B ± 0.10	D	E	F	P ₀	P ₁	P ₂	W	T
NTRH20	2010	2.85	5.45	1.50 ± 0.10	1.75 ± 0.10	5.50 ± 0.05	4.0 ± 0.05	4.0 ± 0.05	2.0 ± 0.05	12.0 ± 0.1	1.0 ± 0.20
NTRH25/26	2512	3.40	6.65								

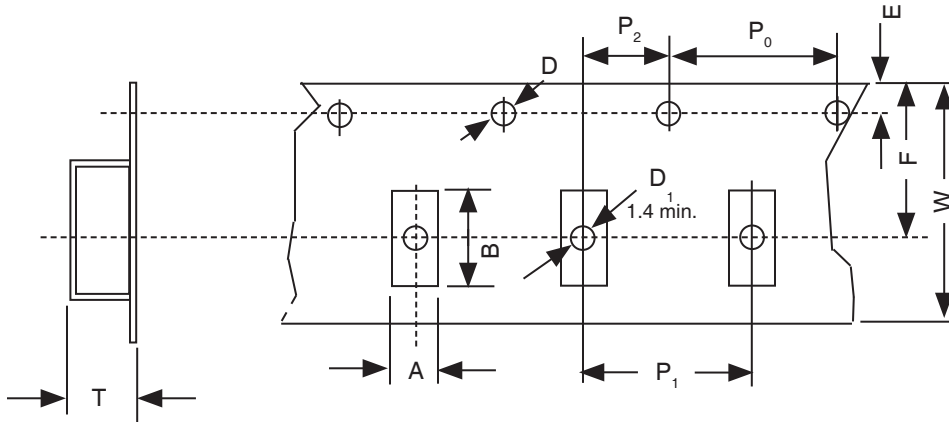

PEAK REFLOW SOLDERING CONDITIONS

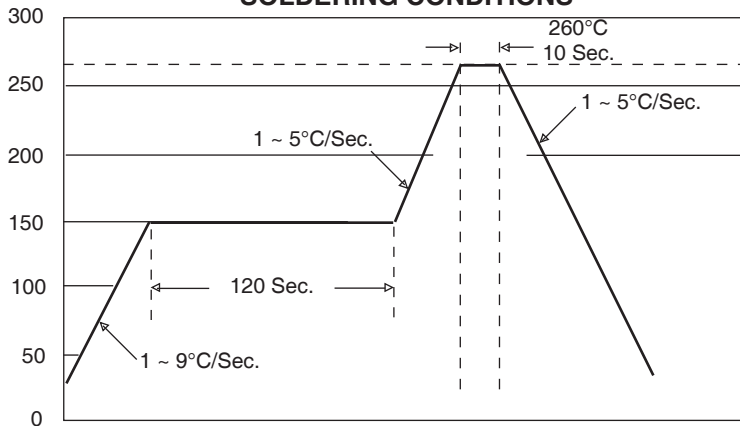

LAND PATTERN DIMENSIONS (mm)

Type	EIA Size	A	B	C
NTRH04	0402	0.50	0.50	0.60 ± 0.2
NTRH06/07	0603	0.80	1.00	0.90 ± 0.2
NTRH10/11	0805	1.00	1.00	1.35 ± 0.2
NTRH12/13	1206	2.00	1.15	1.70 ± 0.2
NTRH15	1210	2.00	1.15	2.50 ± 0.2
NTRH20	2010	3.60	1.40	2.50 ± 0.2
NTRH25/26	2512	4.90	1.60	3.10 ± 0.2

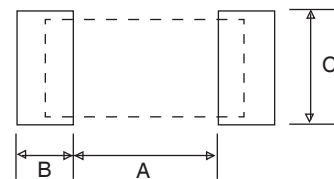

X-ON Electronics

Largest Supplier of Electrical and Electronic Components

Click to view similar products for [nic manufacturer](#):

Other Similar products are found below :

[NMC0603NPO0R6B50TRPF](#) [NMC0603NPO270J100TRPF](#) [NMC1206X5R226K6.3TRPLP2KF](#) [NRE-S100M25V4X7F](#) [NRE-
HS102M25V12.5X16F](#) [NRCA12F1001TRQYF](#) [NRC-S06F2212TRF](#) [NCD180J1KVNPOJTRF](#) [NRC-S06F1692TRF](#)
[NCD102M1KVZ5U.250STRF](#) [NTC-T105K20TRAF](#) [NMC-P1206X7R104K100TRPF](#) [NMC-H1206NPO471K1KVTRPLPF](#) [NML04J9N1TRF](#)
[NRSNA4I4J150TR40KF](#) [NCC0805F261HTRF](#) [NRWA470M35V6.3X11TBF](#) [NACE221M16V6.3X8TR13F](#) [NRSS332M50V18X35.5F](#)
[NDTM106K25F1TRF](#) [NACZ221M50V10X10.5TR13F](#) [NCM15X7R103K50F](#) [NCD103M1KVZ5UF](#) [NRSS682M25V18X35.5F](#)
[NEXC224Z5.5V10.5X8.5TRF](#) [NRLRW221M450V30X35SF](#) [NDTM225K50F2TRF](#) [NRSZ471M50V12.5X20F](#) [NTCL106K35TRDF](#)
[NRWA331M25V10X12.5F](#) [NRSY472M25V16X31.5F](#) [NEXS105Z5.5V28.5X14F](#) [NRLR181M400V25X30SF](#) [NRSZ102M25V12.5X20F](#)
[NUVA33T385TRF](#) [NUVA33V405TRF](#) [NRLMW331M250V30X25F](#) [NRLF103M25V35X20F](#) [NDTM106K35F](#) [NRLMW102M200V35X35F](#)
[NPIS43LS220MTRF](#) [NDTM476K35F2F](#) [NTC-T475K50TRDF](#) [NCD222M1KVZ5UKF](#) [NRLR472M63V25X40SF](#) [NTP157M10TRD\(40\)F](#)
[NPIM74C3R3MTRF](#) [NPI104C100MTRF](#) [NRLM102M100V25X25F](#) [NRLM223M50V 35X50F](#)