

# NuMicro™ NUC200/220 Series Datasheet

*The information described in this document is the exclusive intellectual property of Nuvoton Technology Corporation and shall not be reproduced without permission from Nuvoton.*

*Nuvoton is providing this document only for reference purposes of NuMicro™ microcontroller based system design. Nuvoton assumes no responsibility for errors or omissions.*

*All data and specifications are subject to change without notice.*

*For additional information or questions, please contact: Nuvoton Technology Corporation.*

[www.nuvoton.com](http://www.nuvoton.com)

## Table of Contents

LIST OF FIGURES .....	5
LIST OF TABLES .....	6
1 GENERAL DESCRIPTION .....	7
2 FEATURES .....	8
2.1 NuMicro™ NUC200 Features – Advanced Line .....	8
2.2 NuMicro™ NUC220 Features – USB Line .....	12
3 PARTS INFORMATION LIST AND PIN CONFIGURATION .....	16
3.1 NuMicro™ NUC200/220xxxAN Selection Guide .....	16
3.1.1 NuMicro™ NUC200 Advanced Line Selection Guide .....	16
3.1.2 NuMicro™ NUC220 USB Line Selection Guide .....	16
3.2 Pin Configuration .....	18
3.2.1 NuMicro™ NUC200 Pin Diagram .....	18
3.2.2 NuMicro™ NUC220 Pin Diagram .....	21
3.3 Pin Description .....	24
3.3.1 NuMicro™ NUC200 Pin Description .....	24
3.3.2 NuMicro™ NUC220 Pin Description .....	31
4 BLOCK DIAGRAM .....	38
4.1 NuMicro™ NUC200 Block Diagram .....	38
4.2 NuMicro™ NUC220 Block Diagram .....	39
5 FUNCTIONAL DESCRIPTION .....	40
5.1 ARM® Cortex™-M0 Core .....	40
5.2 System Manager .....	42
5.2.1 Overview .....	42
5.2.2 System Reset .....	42
5.2.3 System Power Distribution .....	43
5.2.4 System Memory Map .....	45
5.2.5 System Timer (SysTick) .....	47
5.2.6 Nested Vectored Interrupt Controller (NVIC) .....	48
5.2.7 System Control (SCS) .....	54
5.3 Clock Controller .....	54
5.3.1 Overview .....	54
5.3.2 Clock Generator .....	56
5.3.3 System Clock and SysTick Clock .....	57
5.3.4 Peripherals Clock .....	58
5.3.5 Power-down Mode Clock .....	58
5.3.6 Frequency Divider Output .....	59
5.4 USB Device Controller (USB) .....	60
5.4.1 Overview .....	60
5.4.2 Features .....	60
5.5 General Purpose I/O (GPIO) .....	61
5.5.1 Overview .....	61



5.5.2	Features .....	61
5.6	I <sup>2</sup> C Serial Interface Controller (I <sup>2</sup> C).....	62
5.6.1	Overview .....	62
5.6.2	Features .....	63
5.7	PWM Generator and Capture Timer (PWM) .....	64
5.7.1	Overview .....	64
5.7.2	Features .....	65
5.8	Real Time Clock (RTC).....	66
5.8.1	Overview .....	66
5.8.2	Features .....	66
5.9	Serial Peripheral Interface (SPI) .....	67
5.9.1	Overview .....	67
5.9.2	Features .....	67
5.10	Timer Controller (TMR).....	68
5.10.1	Overview .....	68
5.10.2	Features .....	68
5.11	Watchdog Timer (WDT).....	69
5.11.1	Overview .....	69
5.11.2	Features .....	69
5.12	Window Watchdog Timer (WWDT).....	69
5.12.1	Overview .....	69
5.12.2	Features .....	69
5.13	UART Interface Controller (UART) .....	70
5.13.1	Overview .....	70
5.13.2	Features .....	72
5.14	PS/2 Device Controller (PS2D).....	73
5.14.1	Overview .....	73
5.14.2	Features .....	73
5.15	I <sup>2</sup> S Controller (I <sup>2</sup> S) .....	74
5.15.1	Overview .....	74
5.15.2	Features .....	74
5.16	Analog-to-Digital Converter (ADC) .....	75
5.16.1	Overview .....	75
5.16.2	Features .....	75
5.17	Analog Comparator (ACMP).....	76
5.17.1	Overview .....	76
5.17.2	Features .....	76
5.18	PDMA Controller (PDMA) .....	77
5.18.1	Overview .....	77
5.18.2	Features .....	77
5.19	Smart Card Host Interface (SC).....	78
5.19.1	Overview .....	78
5.19.2	Features .....	78
5.20	FLASH MEMORY CONTROLLER (FMC) .....	79

	5.20.1	Overview .....	79
	5.20.2	Features .....	79
6		ELECTRICAL CHARACTERISTICS .....	80
	6.1	Absolute Maximum Ratings .....	80
	6.2	DC Electrical Characteristics .....	81
	6.3	AC Electrical Characteristics .....	87
	6.3.1	External 4~24 MHz High Speed Oscillator .....	87
	6.3.2	External 4~24 MHz High Speed Crystal .....	87
	6.3.3	External 32.768 kHz Low Speed Crystal Oscillator .....	88
	6.3.4	Internal 22.1184 MHz High Speed Oscillator .....	88
	6.3.5	Internal 10 kHz Low Speed Oscillator .....	88
	6.4	Analog Characteristics .....	89
	6.4.1	12-bit SARADC Specification .....	89
	6.4.2	LDO and Power Management Specification .....	89
	6.4.3	Low Voltage Reset Specification .....	90
	6.4.4	Brown-out Detector Specification .....	90
	6.4.5	Power-on Reset Specification .....	90
	6.4.6	Temperature Sensor Specification .....	91
	6.4.7	Comparator Specification .....	91
	6.4.8	USB PHY Specification .....	92
	6.5	Flash DC Electrical Characteristics .....	94
7		PACKAGE DIMENSIONS .....	95
	7.1	100-pin LQFP (14x14x1.4 mm footprint 2.0 mm) .....	95
	7.2	64-pin LQFP (7x7x1.4 mm footprint 2.0 mm) .....	96
	7.3	48-pin LQFP (7x7x1.4 mm footprint 2.0 mm) .....	97
8		REVISION HISTORY .....	98

### List of Figures

Figure 3-1 NuMicro™ NUC200 Series Selection Code .....	17
Figure 3-2 NuMicro™ NUC200VxxAN LQFP 100-pin Diagram .....	18
Figure 3-3 NuMicro™ NUC200SxxAN LQFP 64-pin Diagram .....	19
Figure 3-4 NuMicro™ NUC200LxxAN LQFP 48-pin Diagram .....	20
Figure 3-5 NuMicro™ NUC220VxxAN LQFP 100-pin Diagram .....	21
Figure 3-6 NuMicro™ NUC220SxxAN LQFP 64-pin Diagram .....	22
Figure 3-7 NuMicro™ NUC220LxxAN LQFP 48-pin Diagram .....	23
Figure 4-1 NuMicro™ NUC200 Block Diagram .....	38
Figure 4-2 NuMicro™ NUC220 Block Diagram .....	39
Figure 5-1 Functional Controller Diagram .....	40
Figure 5-2 NuMicro™ NUC200 Power Distribution Diagram.....	43
Figure 5-3 NuMicro™ NUC220 Power Distribution Diagram.....	44
Figure 5-4 Clock Generator Global View Diagram.....	55
Figure 5-5 Clock Generator Block Diagram .....	56
Figure 5-6 System Clock Block Diagram .....	57
Figure 5-7 SysTick Clock Control Block Diagram .....	57
Figure 5-8 Clock Source of Frequency Divider .....	59
Figure 5-9 Frequency Divider Block Diagram .....	59
Figure 5-18 I <sup>2</sup> C Bus Timing .....	62
Figure 6-1 Typical Crystal Application Circuit .....	88

### List of Tables

Table 1-1 Connectivity Support Table.....	7
Table 5-1 Address Space Assignments for On-Chip Controllers.....	46
Table 5-2 Exception Model .....	49
Table 5-3 System Interrupt Map.....	50
Table 5-4 Vector Table Format .....	51
Table 5-9 UART Baud Rate Equation.....	70
Table 5-10 UART Baud Rate Setting Table.....	71

## 1 GENERAL DESCRIPTION

The NuMicro™ NUC200 Series 32-bit microcontrollers is embedded with the newest ARM® Cortex™-M0 core with a cost equivalent to traditional 8-bit MCU for industrial control and applications requiring rich communication interfaces. The NuMicro™ NUC200 Series includes NUC200 and NUC220 product lines.

The NuMicro™ NUC200 Advanced Line is embedded with the Cortex™-M0 core running up to 50 MHz and features 32K/64K/128K bytes flash, 8K/16K bytes embedded SRAM, and 4 Kbytes loader ROM for the ISP. It is also equipped with plenty of peripheral devices, such as Timers, Watchdog Timer, Window Watchdog Timer, RTC, PDMA with CRC calculation unit, UART, SPI, I<sup>2</sup>C, I<sup>2</sup>S, PWM Timer, GPIO, PS/2, Smart Card Host, 12-bit ADC, Analog Comparator, Low Voltage Reset Controller and Brown-out Detector.

The NuMicro™ NUC220 USB Line with USB 2.0 full-speed function is embedded with the Cortex™-M0 core running up to 50 MHz and features 32K/64K/128K bytes flash, 8K/16K bytes embedded SRAM, and 4 Kbytes loader ROM for the ISP. It is also equipped with plenty of peripheral devices, such as Timers, Watchdog Timer, Window Watchdog Timer, RTC, PDMA with CRC calculation unit, UART, SPI, I<sup>2</sup>C, I<sup>2</sup>S, PWM Timer, GPIO, PS/2, USB 2.0 FS Device, Smart Card Host, 12-bit ADC, Analog Comparator, Low Voltage Reset Controller and Brown-out Detector.

Product Line	UART	SPI	I <sup>2</sup> C	USB	LIN	CAN	PS/2	I <sup>2</sup> S	SC
NUC200	•	•	•				•	•	•
NUC220	•	•	•	•			•	•	•

Table 1-1 Connectivity Support Table

## 2 FEATURES

The equipped features are dependent on the product line and their sub products.

### 2.1 NuMicro™ NUC200 Features – Advanced Line

- ARM® Cortex™-M0 core
  - Runs up to 50 MHz
  - One 24-bit system timer
  - Supports low power sleep mode
  - Single-cycle 32-bit hardware multiplier
  - NVIC for the 32 interrupt inputs, each with 4-levels of priority
  - Serial Wire Debug supports with 2 watchpoints/4 breakpoints
- Built-in LDO for wide operating voltage ranged from 2.5 V to 5.5 V
- Flash Memory
  - 32K/64K/128K bytes Flash for program code
  - 4 KB flash for ISP loader
  - Supports In-System-Program (ISP) and In-Application-Program (IAP) application code update
  - 512 byte page erase for flash
  - Configurable data flash address and size for 128 KB system, fixed 4 KB data flash for the 32 KB and 64 KB system
  - Supports 2-wired ICP update through SWD/ICE interface
  - Supports fast parallel programming mode by external programmer
- SRAM Memory
  - 8K/16K bytes embedded SRAM
  - Supports PDMA mode
- PDMA (Peripheral DMA)
  - Supports 9 channels PDMA for automatic data transfer between SRAM and peripherals
  - Supports CRC calculation with four common polynomials, CRC-CCITT, CRC-8, CRC-16 and CRC-32
- Clock Control
  - Flexible selection for different applications
  - Built-in 22.1184 MHz high speed oscillator for system operation
    - ◆ Trimmed to  $\pm 1\%$  at  $+25\text{ }^{\circ}\text{C}$  and  $V_{DD} = 5\text{ V}$
    - ◆ Trimmed to  $\pm 3\%$  at  $-40\text{ }^{\circ}\text{C} \sim +85\text{ }^{\circ}\text{C}$  and  $V_{DD} = 2.5\text{ V} \sim 5.5\text{ V}$
  - Built-in 10 kHz low speed oscillator for Watchdog Timer and Wake-up operation
  - Supports one PLL, up to 50 MHz, for high performance system operation
  - External 4~24 MHz high speed crystal input for precise timing operation
  - External 32.768 kHz low speed crystal input for RTC function and low power system operation
- GPIO
  - Four I/O modes:
    - ◆ Quasi-bidirectional
    - ◆ Push-pull output
    - ◆ Open-drain output
    - ◆ Input only with high impedance
  - TTL/Schmitt trigger input selectable
  - I/O pin configured as interrupt source with edge/level setting



- Timer
  - Supports 4 sets of 32-bit timers with 24-bit up-timer and one 8-bit prescale counter
  - Independent clock source for each timer
  - Provides one-shot, periodic, toggle and continuous counting operation modes
  - Supports event counting function
  - Supports input capture function
- Watchdog Timer
  - Multiple clock sources
  - 8 selectable time-out period from 1.6 ms ~ 26.0 sec (depending on clock source)
  - Wake-up from Power-down or Idle mode
  - Interrupt or reset selectable on watchdog time-out
- Window Watchdog Timer
  - 6-bit down counter with 11-bit prescale for wide range window selected
- RTC
  - Supports software compensation by setting frequency compensate register (FCR)
  - Supports RTC counter (second, minute, hour) and calendar counter (day, month, year)
  - Supports Alarm registers (second, minute, hour, day, month, year)
  - Selectable 12-hour or 24-hour mode
  - Automatic leap year recognition
  - Supports periodic time tick interrupt with 8 period options 1/128, 1/64, 1/32, 1/16, 1/8, 1/4, 1/2 and 1 second
  - Supports battery power pin ( $V_{BAT}$ )
  - Supports wake-up function
- PWM/Capture
  - Up to four built-in 16-bit PWM generators providing eight PWM outputs or four complementary paired PWM outputs
  - Each PWM generator equipped with one clock source selector, one clock divider, one 8-bit prescaler and one Dead-Zone generator for complementary paired PWM
  - Up to eight 16-bit digital capture timers (shared with PWM timers) providing eight rising/falling capture inputs
  - Supports Capture interrupt
- UART
  - Up to three UART controllers
  - UART ports with flow control (TXD, RXD, nCTS and nRTS)
  - UART0 with 64-byte FIFO is for high speed
  - UART1/2(optional) with 16-byte FIFO for standard device
  - Supports IrDA (SIR) and LIN function
  - Supports RS-485 9-bit mode and direction control
  - Programmable baud-rate generator up to 1/16 system clock
  - Supports PDMA mode
- SPI
  - Up to four sets of SPI controllers
  - The maximum SPI clock rate of Master can up to 36 MHz (chip working at 5V)
  - The maximum SPI clock rate of Slave can up to 18 MHz (chip working at 5V)
  - Supports SPI Master/Slave mode
  - Full duplex synchronous serial data transfer
  - Variable length of transfer data from 8 to 32 bits
  - MSB or LSB first data transfer
  - Rx and Tx on both rising or falling edge of serial clock independently

- Two slave/device select lines in Master mode, and one slave/device select line in Slave mode
- Supports Byte Suspend mode in 32-bit transmission
- Supports PDMA mode
- Supports three wire, no slave select signal, bi-direction interface
- I<sup>2</sup>C
  - Up to two sets of I<sup>2</sup>C device
  - Master/Slave mode
  - Bidirectional data transfer between masters and slaves
  - Multi-master bus (no central master)
  - Arbitration between simultaneously transmitting masters without corruption of serial data on the bus
  - Serial clock synchronization allowing devices with different bit rates to communicate via one serial bus
  - Serial clock synchronization used as a handshake mechanism to suspend and resume serial transfer
  - Programmable clocks allowing for versatile rate control
  - Supports multiple address recognition (four slave address with mask option)
  - Supports wake-up function
- I<sup>2</sup>S
  - Interface with external audio CODEC
  - Operate as either Master or Slave mode
  - Capable of handling 8-, 16-, 24- and 32-bit word sizes
  - Supports mono and stereo audio data
  - Supports I<sup>2</sup>S and MSB justified data format
  - Provides two 8 word FIFO data buffers, one for transmitting and the other for receiving
  - Generates interrupt requests when buffer levels cross a programmable boundary
  - Supports two DMA requests, one for transmitting and the other for receiving
- PS/2 Device
  - Host communication inhibit and request to send detection
  - Reception frame error detection
  - Programmable 1 to 16 bytes transmit buffer to reduce CPU intervention
  - Double buffer for data reception
  - Software override bus
- ADC
  - 12-bit SAR ADC with 760 kSPS
  - Up to 8-ch single-end input or 4-ch differential input
  - Single scan/single cycle scan/continuous scan
  - Each channel with individual result register
  - Scan on enabled channels
  - Threshold voltage detection
  - Conversion started by software programming or external input
  - Supports PDMA mode
- Analog Comparator
  - Up to two analog comparators
  - External input or internal Band-gap voltage selectable at negative node
  - Interrupt when compare result change
  - Supports Power-down wake-up
- Smart Card Host (SC)

- Compliant to ISO-7816-3 T=0, T=1
- Supports up to three ISO-7816-3 ports
- Separate receive / transmit 4 bytes entry FIFO for data payloads
- Programmable transmission clock frequency
- Programmable receiver buffer trigger level
- Programmable guard time selection (11 ETU ~ 266 ETU)
- One 24-bit and two 8-bit time-out counters for Answer to Request (ATR) and waiting times processing
- Supports auto inverse convention function
- Supports transmitter and receiver error retry and error limit function
- Supports hardware activation sequence process
- Supports hardware warm reset sequence process
- Supports hardware deactivation sequence process
- Supports hardware auto deactivation sequence when detecting the card removal
- 96-bit unique ID (UID)
- One built-in temperature sensor with 1°C resolution
- Brown-out Detector
  - With 4 levels: 4.4 V/3.7 V/2.7 V/2.2 V
  - Supports Brown-out Interrupt and Reset option
- Low Voltage Reset
  - Threshold voltage level: 2.0 V
- Operating Temperature: -40°C ~ 85°C
- Packages:
  - All Green package (RoHS)
  - LQFP 100-pin / 64-pin / 48-pin

## 2.2 NuMicro™ NUC220 Features – USB Line

- ARM® Cortex™-M0 core
  - Runs up to 50 MHz
  - One 24-bit system timer
  - Supports low power sleep mode
  - Single-cycle 32-bit hardware multiplier
  - NVIC for the 32 interrupt inputs, each with 4-levels of priority
  - Serial Wire Debug supports with 2 watchpoints/4 breakpoints
- Built-in LDO for wide operating voltage ranges from 2.5 V to 5.5 V
- Flash Memory
  - 32K/64K/128K bytes Flash for program code
  - 4 KB flash for ISP loader
  - Supports In-System-Program (ISP) and In-Application-Program (IAP) application code update
  - 512 byte page erase for flash
  - Configurable data flash address and size for 128 KB system, fixed 4 KB data flash for the 32 KB and 64 KB system
  - Supports 2-wired ICP update through SWD/ICE interface
  - Supports fast parallel programming mode by external programmer
- SRAM Memory
  - 8K/16K bytes embedded SRAM
  - Supports PDMA mode
- PDMA (Peripheral DMA)
  - Supports 9 channels PDMA for automatic data transfer between SRAM and peripherals
  - Supports CRC calculation with four common polynomials, CRC-CCITT, CRC-8, CRC-16 and CRC-32
- Clock Control
  - Flexible selection for different applications
  - Built-in 22.1184 MHz high speed oscillator for system operation
    - ◆ Trimmed to  $\pm 1\%$  at  $+25\text{ }^{\circ}\text{C}$  and  $V_{DD} = 5\text{ V}$
    - ◆ Trimmed to  $\pm 3\%$  at  $-40\text{ }^{\circ}\text{C} \sim +85\text{ }^{\circ}\text{C}$  and  $V_{DD} = 2.5\text{ V} \sim 5.5\text{ V}$
  - Built-in 10 kHz low speed oscillator for Watchdog Timer and Wake-up operation
  - Supports one PLL, up to 50 MHz, for high performance system operation
  - External 4~24 MHz high speed crystal input for USB and precise timing operation
  - External 32.768 kHz low speed crystal input for RTC function and low power system operation
- GPIO
  - Four I/O modes:
    - ◆ Quasi-bidirectional
    - ◆ Push-pull output
    - ◆ Open-drain output
    - ◆ Input only with high impedance
  - TTL/Schmitt trigger input selectable
  - I/O pin configured as interrupt source with edge/level setting
- Timer

- Supports 4 sets of 32-bit timers with 24-bit up-timer and one 8-bit prescale counter
- Independent clock source for each timer
- Provides one-shot, periodic, toggle and continuous counting operation modes
- Supports event counting function
- Supports input capture function
- Watchdog Timer
  - Multiple clock sources
  - 8 selectable time-out period from 1.6 ms ~ 26.0 sec (depending on clock source)
  - Wake-up from Power-down or Idle mode
  - Interrupt or reset selectable on watchdog time-out
- Window Watchdog Timer
  - 6-bit down counter with 11-bit prescale for wide range window selected
- RTC
  - Supports software compensation by setting frequency compensate register (FCR)
  - Supports RTC counter (second, minute, hour) and calendar counter (day, month, year)
  - Supports Alarm registers (second, minute, hour, day, month, year)
  - Selectable 12-hour or 24-hour mode
  - Automatic leap year recognition
  - Supports periodic time tick interrupt with 8 period options 1/128, 1/64, 1/32, 1/16, 1/8, 1/4, 1/2 and 1 second
  - Supports battery power pin ( $V_{BAT}$ )
  - Supports wake-up function
- PWM/Capture
  - Up to four built-in 16-bit PWM generators providing eight PWM outputs or four complementary paired PWM outputs
  - Each PWM generator equipped with one clock source selector, one clock divider, one 8-bit prescaler and one Dead-Zone generator for complementary paired PWM
  - Up to eight 16-bit digital capture timers (shared with PWM timers) providing eight rising/falling capture inputs
  - Supports Capture interrupt
- UART
  - Up to three UART controllers
  - UART ports with flow control (TXD, RXD, nCTS and nRTS)
  - UART0 with 64-byte FIFO is for high speed
  - UART1/2(optional) with 16-byte FIFO for standard device
  - Supports IrDA (SIR) and LIN function
  - Supports RS-485 9-bit mode and direction control
  - Programmable baud-rate generator up to 1/16 system clock
  - Supports PDMA mode
- SPI
  - Up to four sets of SPI controllers
  - The maximum SPI clock rate of Master can up to 36 MHz (chip working at 5V)
  - The maximum SPI clock rate of Slave can up to 18 MHz (chip working at 5V)
  - Supports SPI Master/Slave mode
  - Full duplex synchronous serial data transfer
  - Variable length of transfer data from 8 to 32 bits
  - MSB or LSB first data transfer
  - Rx and Tx on both rising or falling edge of serial clock independently
  - Two slave/device select lines in Master mode, and one slave/device select line in Slave mode

- Supports Byte Suspend mode in 32-bit transmission
- Supports PDMA mode
- Supports three wire, no slave select signal, bi-direction interface
- I<sup>2</sup>C
  - Up to two sets of I<sup>2</sup>C device
  - Master/Slave mode
  - Bidirectional data transfer between masters and slaves
  - Multi-master bus (no central master)
  - Arbitration between simultaneously transmitting masters without corruption of serial data on the bus
  - Serial clock synchronization allowing devices with different bit rates to communicate via one serial bus
  - Serial clock synchronization used as a handshake mechanism to suspend and resume serial transfer
  - Programmable clocks allowing for versatile rate control
  - Supports multiple address recognition (four slave address with mask option)
  - Supports wake-up function
- I<sup>2</sup>S
  - Interface with external audio CODEC
  - Operate as either Master or Slave mode
  - Capable of handling 8-, 16-, 24- and 32-bit word sizes
  - Supports mono and stereo audio data
  - Supports I<sup>2</sup>S and MSB justified data format
  - Provides two 8 word FIFO data buffers, one for transmitting and the other for receiving
  - Generates interrupt requests when buffer levels cross a programmable boundary
  - Supports two DMA requests, one for transmitting and the other for receiving
- PS/2 Device
  - Host communication inhibit and request to send detection
  - Reception frame error detection
  - Programmable 1 to 16 bytes transmit buffer to reduce CPU intervention
  - Double buffer for data reception
  - Software override bus
- USB 2.0 Full-Speed Device
  - One set of USB 2.0 FS Device 12 Mbps
  - On-chip USB Transceiver
  - Provides 1 interrupt source with 4 interrupt events
  - Supports Control, Bulk In/Out, Interrupt and Isochronous transfers
  - Auto suspend function when no bus signaling for 3 ms
  - Provides 6 programmable endpoints
  - Includes 512 Bytes internal SRAM as USB buffer
  - Provides remote wake-up capability
- ADC
  - 12-bit SAR ADC with 760 kSPS
  - Up to 8-ch single-end input or 4-ch differential input
  - Single scan/single cycle scan/continuous scan
  - Each channel with individual result register
  - Scan on enabled channels
  - Threshold voltage detection
  - Conversion started by software programming or external input

- Supports PDMA mode
- Analog Comparator
  - Up to two analog comparators
  - External input or internal Band-gap voltage selectable at negative node
  - Interrupt when compare result change
  - Supports Power-down wake-up
- Smart Card Host (SC)
  - Compliant to ISO-7816-3 T=0, T=1
  - Supports up to three ISO-7816-3 ports
  - Separate receive / transmit 4 bytes entry FIFO for data payloads
  - Programmable transmission clock frequency
  - Programmable receiver buffer trigger level
  - Programmable guard time selection (11 ETU ~ 266 ETU)
  - One 24-bit and two 8-bit time-out counters for Answer to Request (ATR) and waiting times processing
  - Supports auto inverse convention function
  - Supports transmitter and receiver error retry and error limit function
  - Supports hardware activation sequence process
  - Supports hardware warm reset sequence process
  - Supports hardware deactivation sequence process
  - Supports hardware auto deactivation sequence when detecting the card removal
- 96-bit unique ID (UID)
- One built-in temperature sensor with 1°C resolution
- Brown-out Detector
  - With 4 levels: 4.4 V/3.7 V/2.7 V/2.2 V
  - Supports Brown-out Interrupt and Reset option
- Low Voltage Reset
  - Threshold voltage level: 2.0 V
- Operating Temperature: -40°C ~ 85°C
- Packages:
  - All Green package (RoHS)
  - LQFP 100-pin / 64-pin / 48-pin



### 3 PARTS INFORMATION LIST AND PIN CONFIGURATION

#### 3.1 NuMicro™ NUC200/220xxxAN Selection Guide

##### 3.1.1 NuMicro™ NUC200 Advanced Line Selection Guide

Part number	APROM	RAM	Data Flash	ISP Loader ROM	I/O	Timer	Connectivity						I <sup>2</sup> S	SC	Comp.	PWM	ADC	RTC	ISP ICP IAP	Package
							UART	SPI	I <sup>2</sup> C	USB	LIN	CAN								
NUC200LC2AN	32 KB	8 KB	4 KB	4 KB	up to 35	4x32-bit	2	1	2	-	-	-	1	2	1	6	7x12-bit	v	v	LQFP48
NUC200LD2AN	64 KB	8 KB	4KB	4 KB	up to 35	4x32-bit	2	1	2	-	-	-	1	2	1	6	7x12-bit	v	v	LQFP48
NUC200LE3AN	128 KB	16 KB	Definable	4 KB	up to 35	4x32-bit	2	1	2	-	-	-	1	2	1	6	7x12-bit	v	v	LQFP48
NUC200SC2AN	32 KB	8 KB	4 KB	4 KB	up to 49	4x32-bit	3	2	2	-	-	-	1	2	2	6	7x12-bit	v	v	LQFP64
NUC200SD2AN	64 KB	8 KB	4KB	4 KB	up to 49	4x32-bit	3	2	2	-	-	-	1	2	2	6	7x12-bit	v	v	LQFP64
NUC200SE3AN	128 KB	16 KB	Definable	4 KB	up to 49	4x32-bit	3	2	2	-	-	-	1	2	2	6	7x12-bit	v	v	LQFP64
NUC200VE3AN	128 KB	16 KB	Definable	4 KB	up to 83	4x32-bit	3	4	2	-	-	-	1	3	2	8	8x12-bit	v	v	LQFP100

##### 3.1.2 NuMicro™ NUC220 USB Line Selection Guide

Part number	APROM	RAM	Data Flash	ISP Loader ROM	I/O	Timer	Connectivity						I <sup>2</sup> S	SC	Comp.	PWM	ADC	RTC	ISP ICP IAP	Package
							UART	SPI	I <sup>2</sup> C	USB	LIN	CAN								
NUC220LC2AN	32 KB	8 KB	4 KB	4 KB	up to 31	4x32-bit	2	1	2	1	-	-	1	2	1	4	7x12-bit	v	v	LQFP48
NUC220LD2AN	64 KB	8 KB	4 KB	4 KB	up to 31	4x32-bit	2	1	2	1	-	-	1	2	1	4	7x12-bit	v	v	LQFP48
NUC220LE3AN	128 KB	16 KB	Definable	4 KB	up to 31	4x32-bit	2	1	2	1	-	-	1	2	1	4	7x12-bit	v	v	LQFP48
NUC220SC2AN	32 KB	8 KB	4 KB	4 KB	up to 45	4x32-bit	2	2	2	1	-	-	1	2	2	6	7x12-bit	v	v	LQFP64
NUC220SD2AN	64 KB	8 KB	8 KB	4 KB	up to 45	4x32-bit	2	2	2	1	-	-	1	2	2	6	7x12-bit	v	v	LQFP64
NUC220SE3AN	128 KB	16 KB	Definable	4 KB	up to 45	4x32-bit	2	2	2	1	-	-	1	2	2	6	7x12-bit	v	v	LQFP64
NUC220VE3AN	128 KB	16 KB	Definable	4 KB	up to 79	4x32-bit	3	4	2	1	-	-	1	3	2	8	8x12-bit	v	v	LQFP100

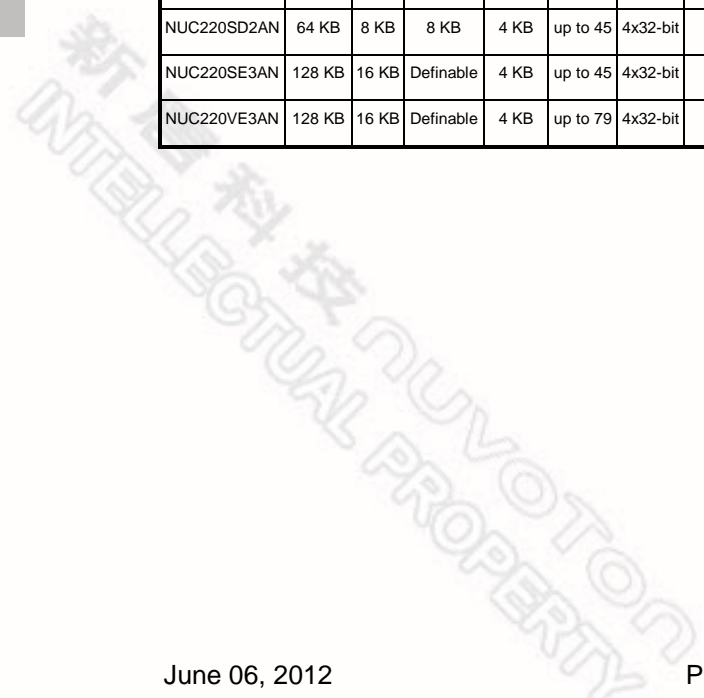



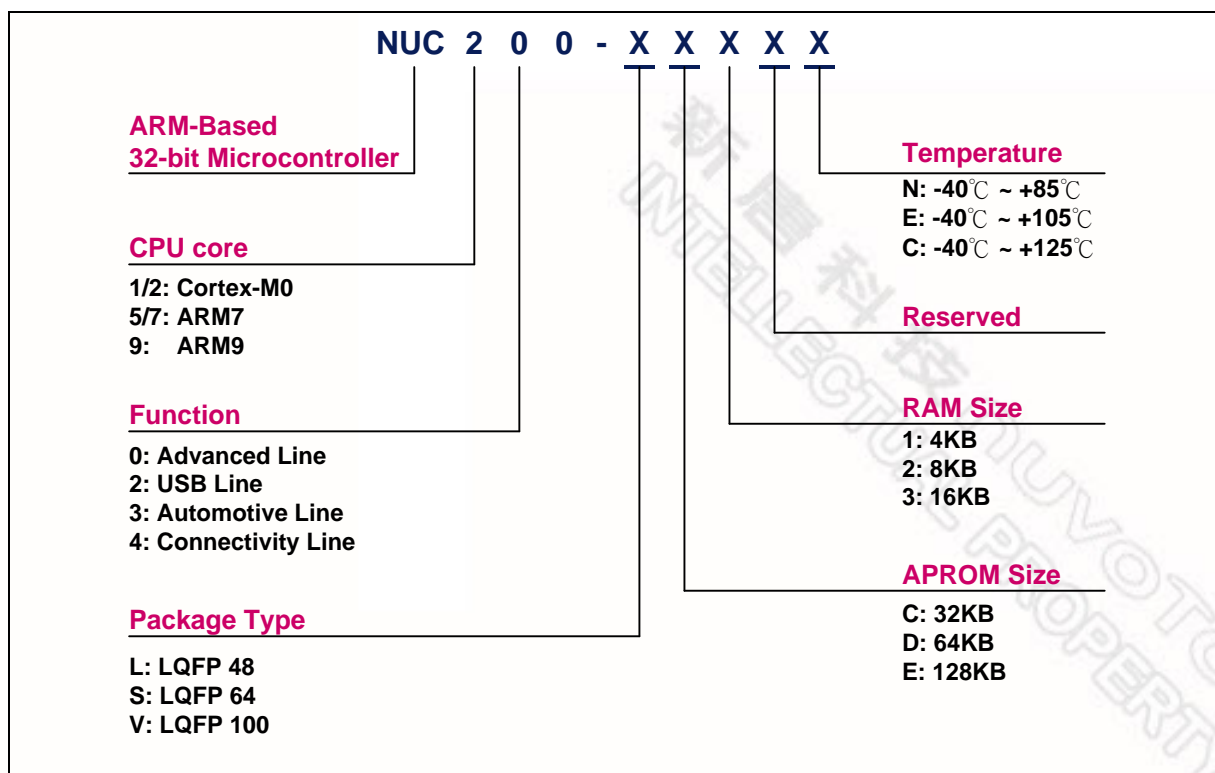

Figure 3-1 NuMicro™ NUC200 Series Selection Code



### 3.2 Pin Configuration

#### 3.2.1 NuMicro™ NUC200 Pin Diagram

##### 3.2.1.1 NuMicro™ NUC200VxxAN LQFP 100-pin

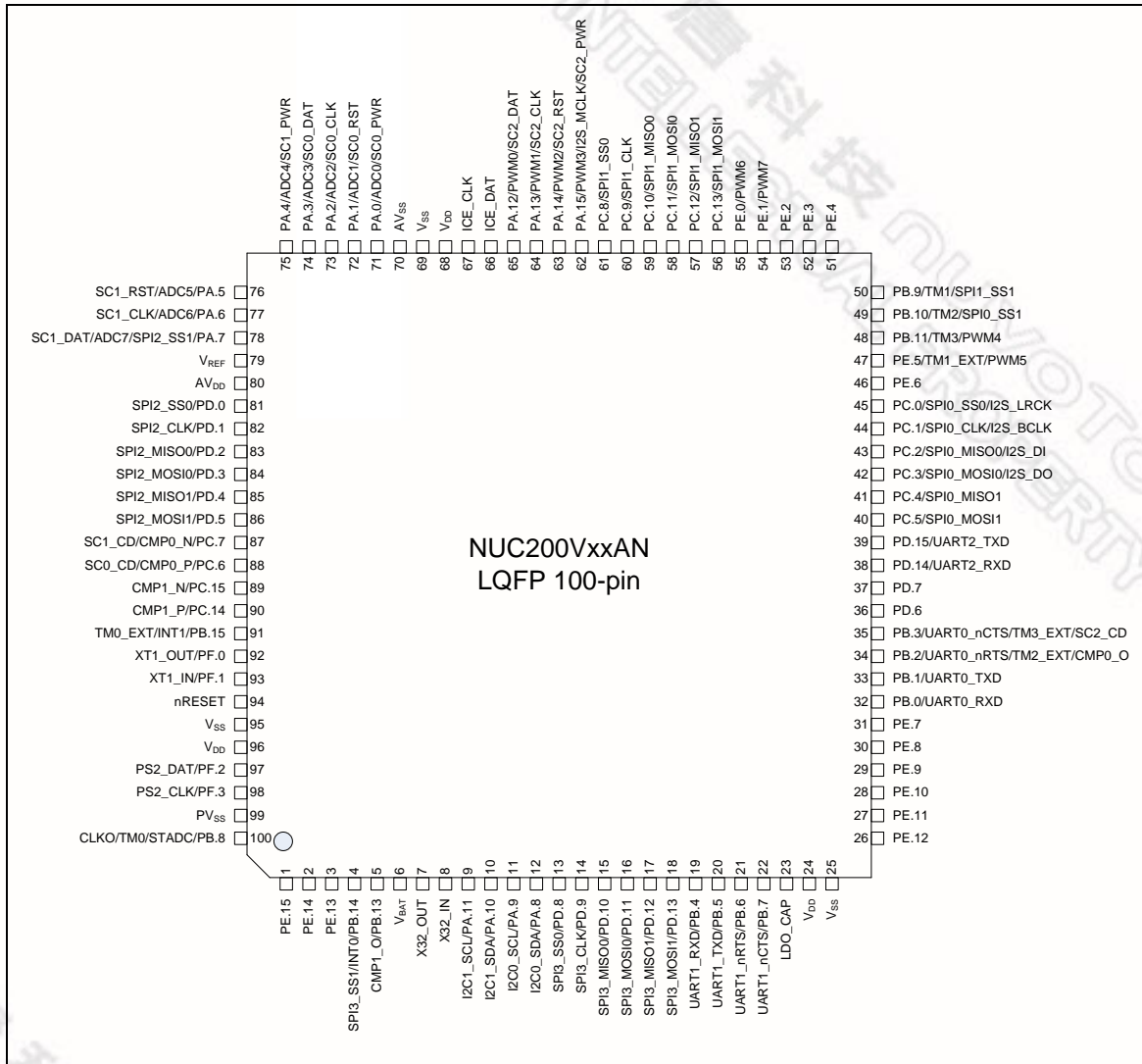

Figure 3-2 NuMicro™ NUC200VxxAN LQFP 100-pin Diagram

3.2.1.2 NuMicro™ NUC200RxxAN LQFP 64-pin

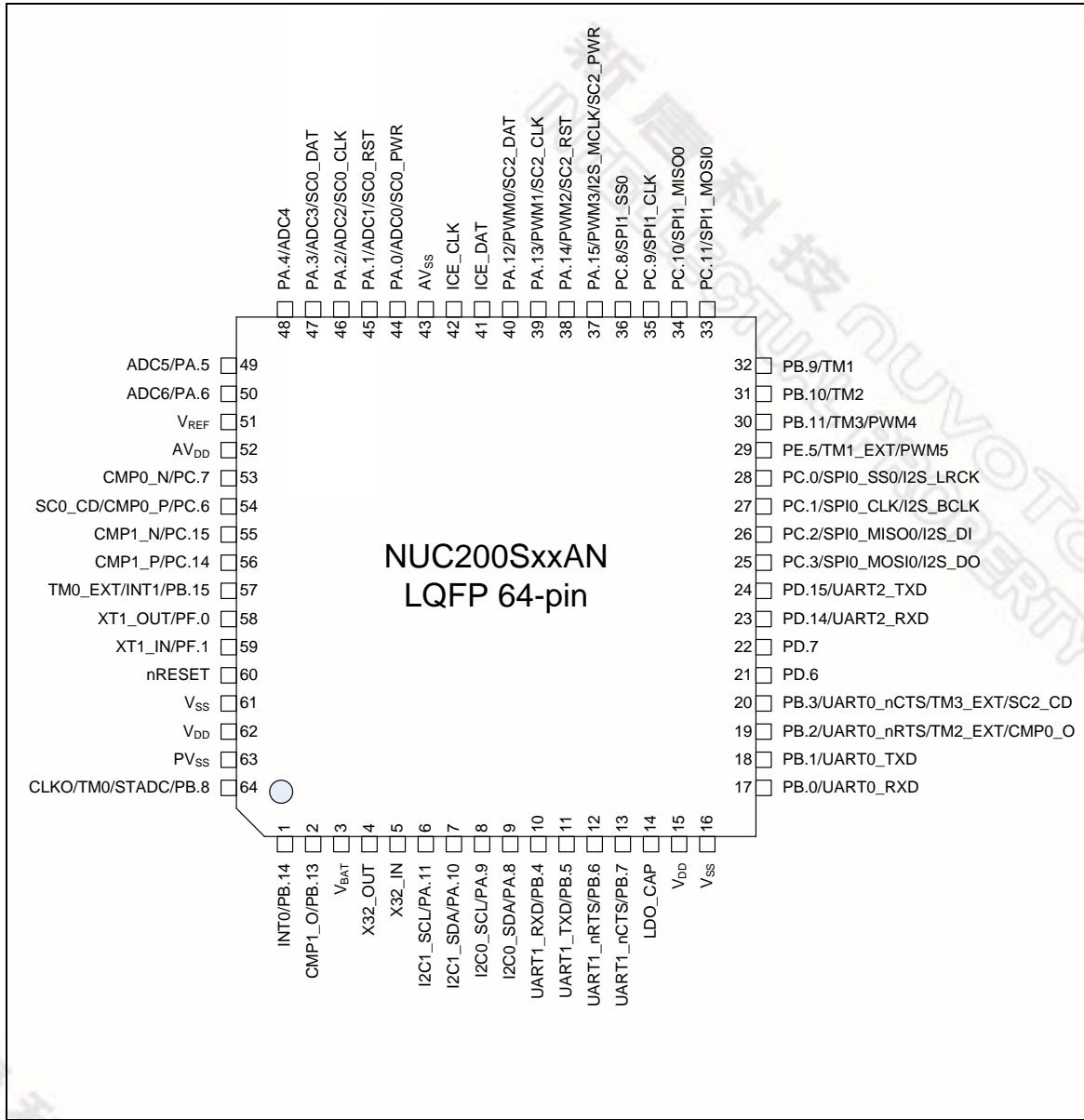

Figure 3-3 NuMicro™ NUC200SxxAN LQFP 64-pin Diagram



3.2.1.3 NuMicro™ NUC200LxxAN LQFP 48-pin

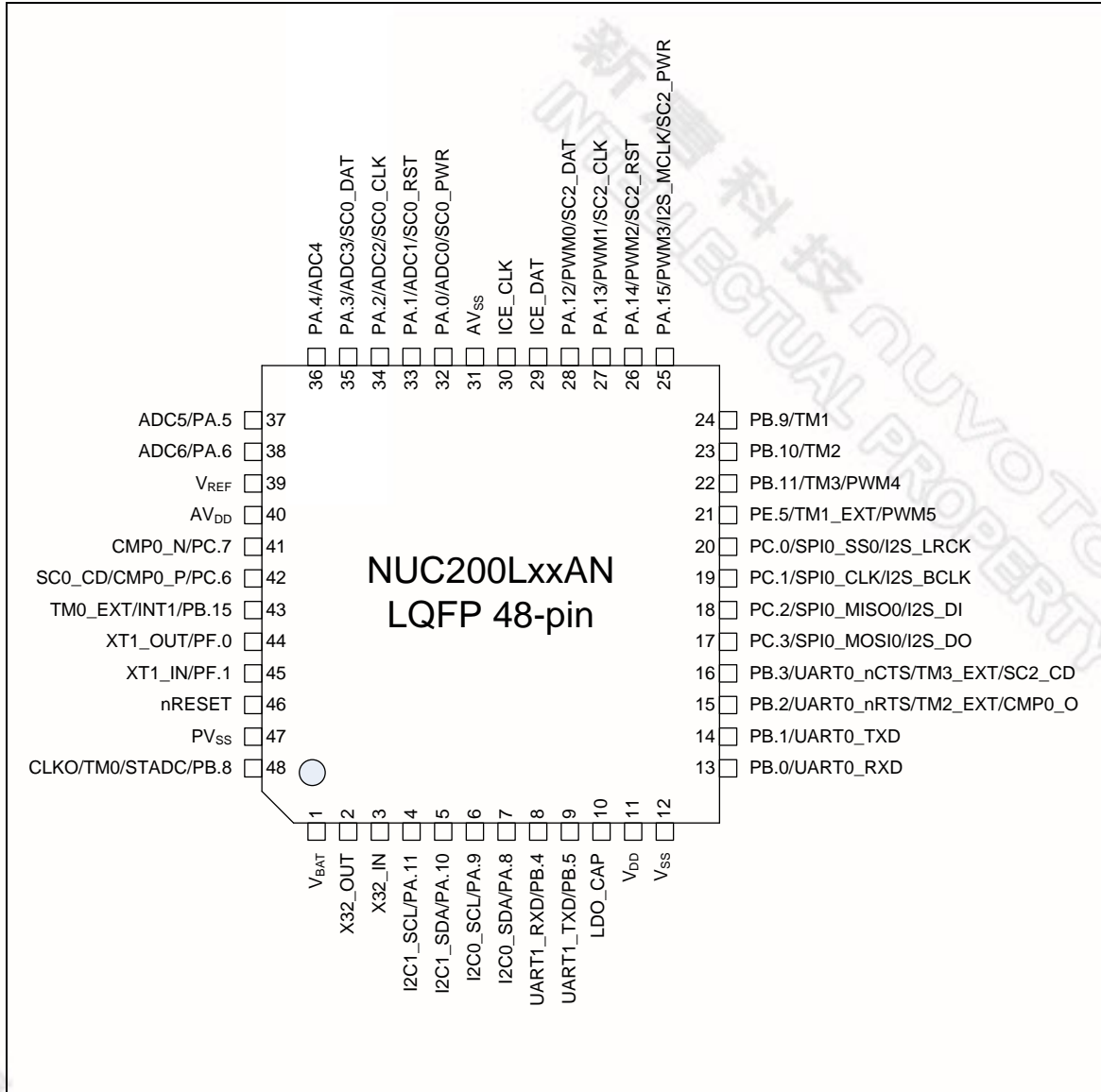

Figure 3-4 NuMicro™ NUC200LxxAN LQFP 48-pin Diagram

### 3.2.2 NuMicro™ NUC220 Pin Diagram

#### 3.2.2.1 NuMicro™ NUC220VxxAN LQFP 100-pin

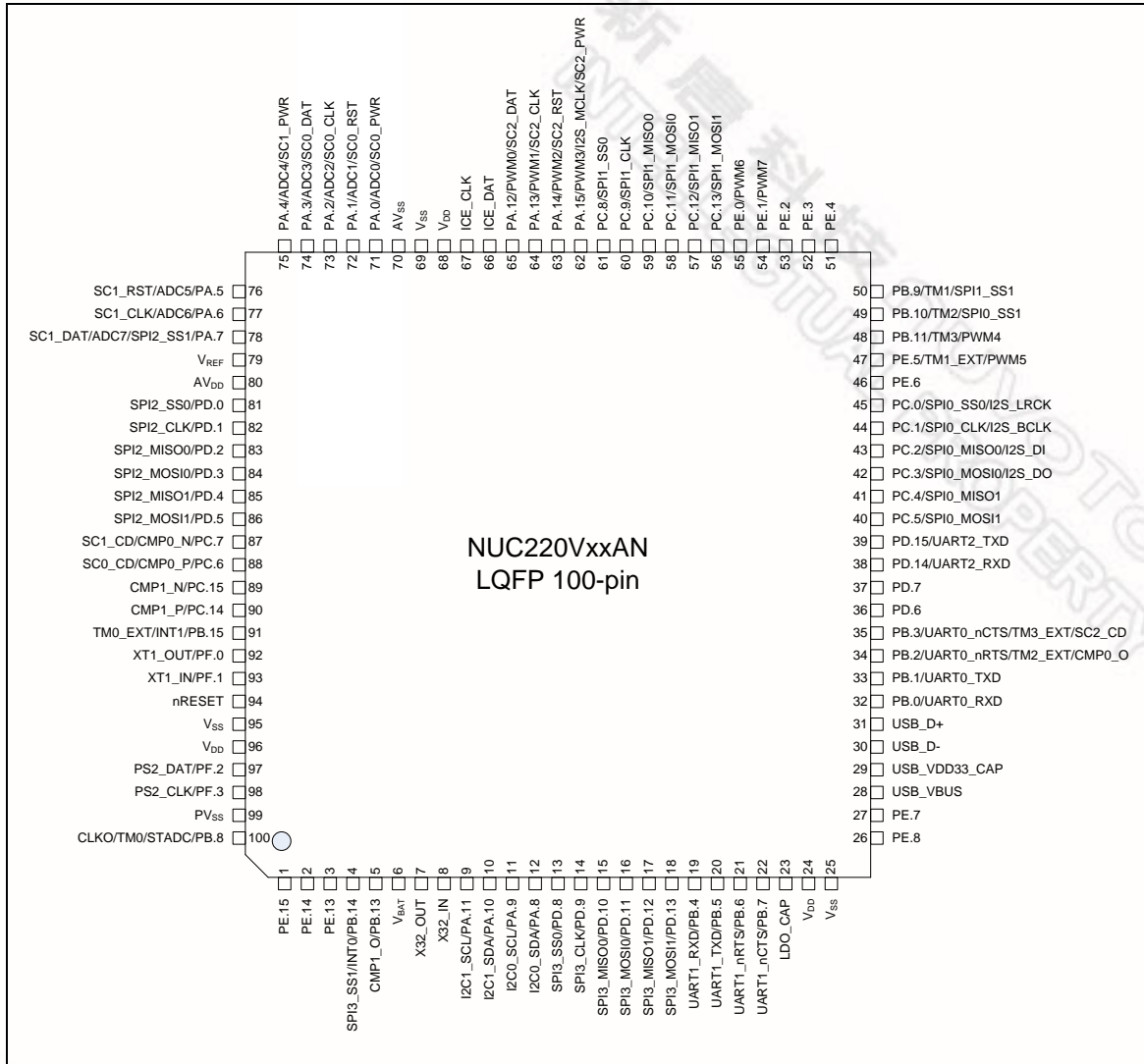

Figure 3-5 NuMicro™ NUC220VxxAN LQFP 100-pin Diagram

3.2.2.2 NuMicro™ NUC220RxxAN LQFP 64-pin

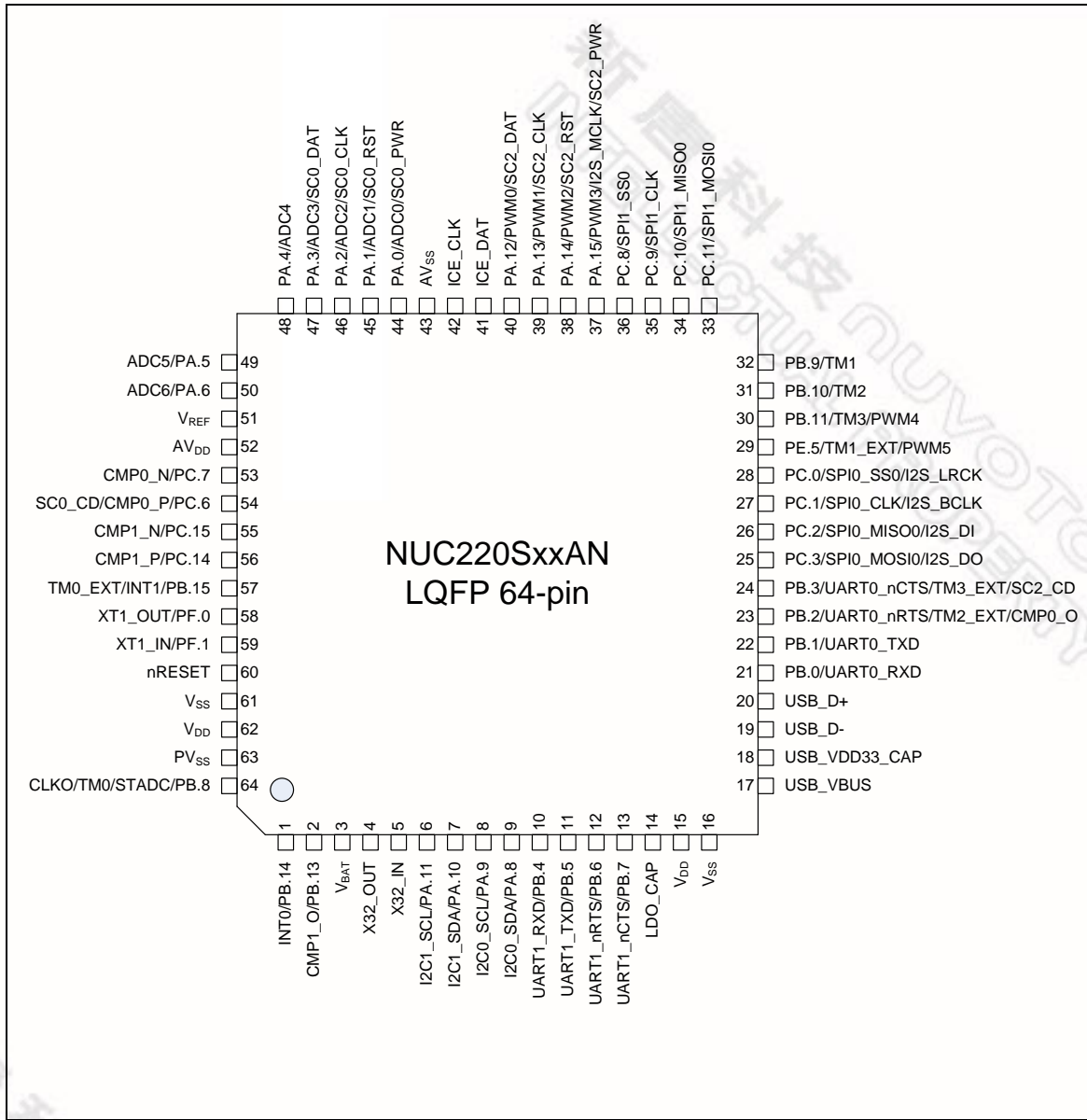

Figure 3-6 NuMicro™ NUC220SxxAN LQFP 64-pin Diagram

3.2.2.3 NuMicro™ NUC220LxxAN LQFP 48-pin

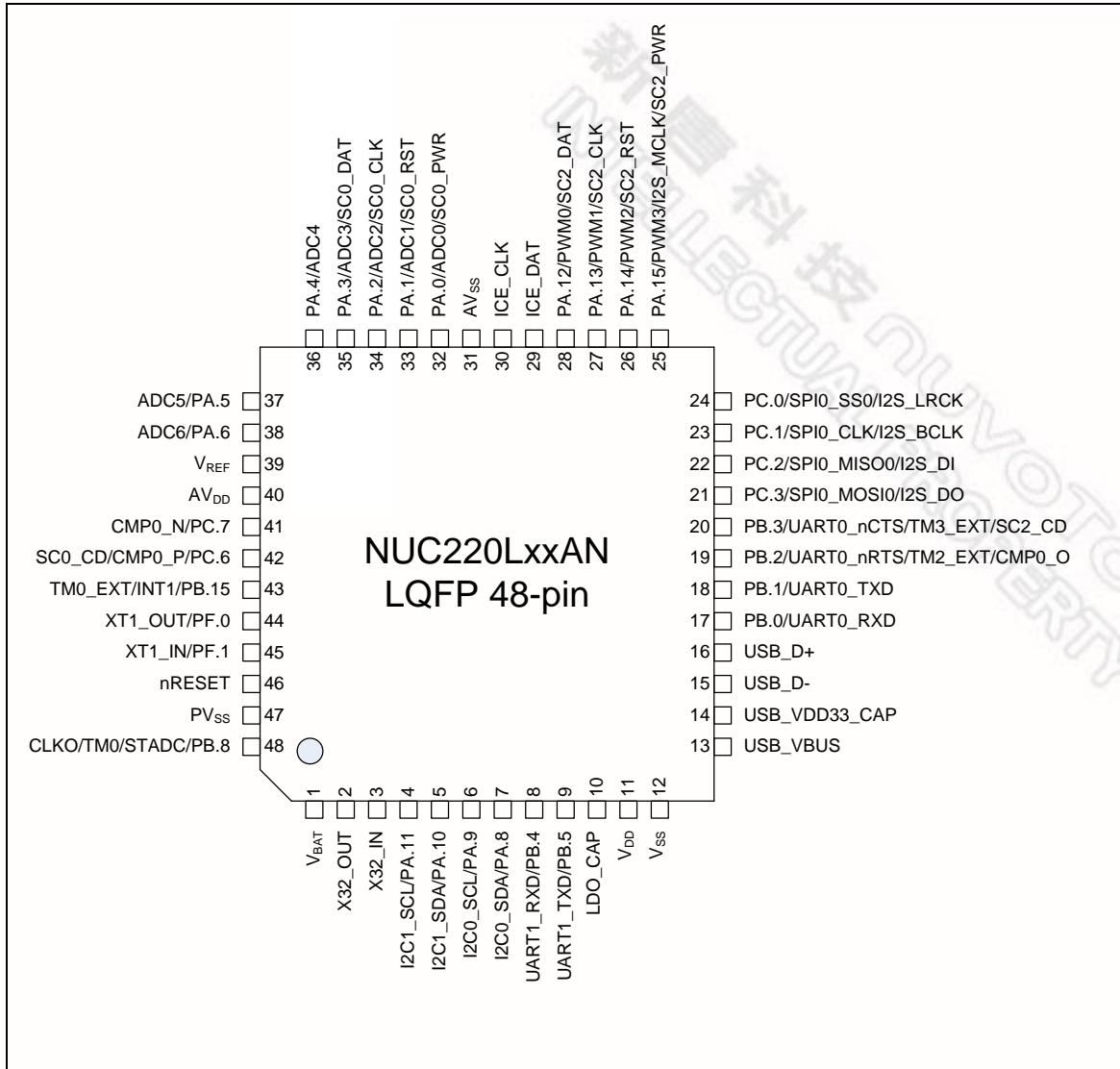

Figure 3-7 NuMicro™ NUC220LxxAN LQFP 48-pin Diagram

### 3.3 Pin Description

#### 3.3.1 NuMicro™ NUC200 Pin Description

Pin No.			Pin Name	Pin Type	Description
LQFP 100-pin	LQFP 64-pin	LQFP 48-pin			
1			PE.15	I/O	General purpose digital I/O pin.
2			PE.14	I/O	General purpose digital I/O pin.
3			PE.13	I/O	General purpose digital I/O pin.
4	1		PB.14	I/O	General purpose digital I/O pin.
			INT0	I	External interrupt0 input pin.
			SPI3_SS1	I/O	2 <sup>nd</sup> SPI3 slave select pin.
5	2		PB.13	I/O	General purpose digital I/O pin.
			CMP1_O	O	Comparator1 output pin.
6	3	1	V <sub>BAT</sub>	P	Power supply by batteries for RTC.
7	4	2	X32_OUT	O	External 32.768 kHz (low speed) crystal output pin.
8	5	3	X32_IN	I	External 32.768 kHz (low speed) crystal input pin.
9	6	4	PA.11	I/O	General purpose digital I/O pin.
			I2C1_SCL	I/O	I <sup>2</sup> C1 clock pin.
10	7	5	PA.10	I/O	General purpose digital I/O pin.
			I2C1_SDA	I/O	I <sup>2</sup> C1 data input/output pin.
11	8	6	PA.9	I/O	General purpose digital I/O pin.
			I2C0_SCL	I/O	I <sup>2</sup> C0 clock pin.
12	9	7	PA.8	I/O	General purpose digital I/O pin.
			I2C0_SDA	I/O	I <sup>2</sup> C0 data input/output pin.
13			PD.8	I/O	General purpose digital I/O pin.
			SPI3_SS0	I/O	1 <sup>st</sup> SPI3 slave select pin.
14			PD.9	I/O	General purpose digital I/O pin.
			SPI3_CLK	I/O	SPI3 serial clock pin.
15			PD.10	I/O	General purpose digital I/O pin.
			SPI3_MISO0	I/O	1 <sup>st</sup> SPI3 MISO (Master In, Slave Out) pin.
16			PD.11	I/O	General purpose digital I/O pin.





Pin No.			Pin Name	Pin Type	Description
LQFP 100-pin	LQFP 64-pin	LQFP 48-pin			
			SPI3_MOSI0	I/O	1 <sup>st</sup> SPI3 MOSI (Master Out, Slave In) pin.
17			PD.12	I/O	General purpose digital I/O pin.
			SPI3_MISO1	I/O	2 <sup>nd</sup> SPI3 MISO (Master In, Slave Out) pin.
18			PD.13	I/O	General purpose digital I/O pin.
			SPI3_MOSI1	I/O	2 <sup>nd</sup> SPI3 MOSI (Master Out, Slave In) pin.
19	10	8	PB.4	I/O	General purpose digital I/O pin.
			UART1_RXD	I	Data receiver input pin for UART1.
20	11	9	PB.5	I/O	General purpose digital I/O pin.
			UART1_TXD	O	Data transmitter output pin for UART1.
21	12		PB.6	I/O	General purpose digital I/O pin.
			UART1_nRTS	O	Request to Send output pin for UART1.
22	13		PB.7	I/O	General purpose digital I/O pin.
			UART1_nCTS	I	Clear to Send input pin for UART1.
23	14	10	LDO_CAP	P	LDO output pin.
24	15	11	V <sub>DD</sub>	P	Power supply for I/O ports and LDO source for internal PLL and digital circuit.
25	16	12	V <sub>SS</sub>	P	Ground pin for digital circuit.
26			PE.12	I/O	General purpose digital I/O pin.
27			PE.11	I/O	General purpose digital I/O pin.
28			PE.10	I/O	General purpose digital I/O pin.
29			PE.9	I/O	General purpose digital I/O pin.
30			PE.8	I/O	General purpose digital I/O pin.
31			PE.7	I/O	General purpose digital I/O pin.
32	17	13	PB.0	I/O	General purpose digital I/O pin.
			UART0_RXD	I	Data receiver input pin for UART0.
33	18	14	PB.1	I/O	General purpose digital I/O pin.
			UART0_TXD	O	Data transmitter output pin for UART0.
34	19	15	PB.2	I/O	General purpose digital I/O pin.
			UART0_nRTS	O	Request to Send output pin for UART0.
			TM2_EXT	I	Timer2 external capture input pin.
			CMP0_O	O	Comparator0 output pin.

Pin No.			Pin Name	Pin Type	Description
LQFP 100-pin	LQFP 64-pin	LQFP 48-pin			
35	20	16	PB.3	I/O	General purpose digital I/O pin.
			UART0_nCTS	I	Clear to Send input pin for UART0.
			TM3_EXT	I	Timer3 external capture input pin.
			SC2_CD	I	SmartCard2 card detect pin.
36	21		PD.6	I/O	General purpose digital I/O pin.
37	22		PD.7	I/O	General purpose digital I/O pin.
38	23		PD.14	I/O	General purpose digital I/O pin.
			UART2_RXD	I	Data receiver input pin for UART2.
39	24		PD.15	I/O	General purpose digital I/O pin.
			UART2_TXD	O	Data transmitter output pin for UART2.
40			PC.5	I/O	General purpose digital I/O pin.
			SPI0_MOSI1	I/O	2 <sup>nd</sup> SPI0 MOSI (Master Out, Slave In) pin.
41			PC.4	I/O	General purpose digital I/O pin.
			SPI0_MISO1	I/O	2 <sup>nd</sup> SPI0 MISO (Master In, Slave Out) pin.
42	25	17	PC.3	I/O	General purpose digital I/O pin.
			SPI0_MOSI0	I/O	1 <sup>st</sup> SPI0 MOSI (Master Out, Slave In) pin.
			I2S_DO	O	I <sup>2</sup> S data output.
43	26	18	PC.2	I/O	General purpose digital I/O pin.
			SPI0_MISO0	I/O	1 <sup>st</sup> SPI0 MISO (Master In, Slave Out) pin.
			I2S_DI	I	I <sup>2</sup> S data input.
44	27	19	PC.1	I/O	General purpose digital I/O pin.
			SPI0_CLK	I/O	SPI0 serial clock pin.
			I2S_BCLK	I/O	I <sup>2</sup> S bit clock pin.
45	28	20	PC.0	I/O	General purpose digital I/O pin.
			SPI0_SS0	I/O	1 <sup>st</sup> SPI0 slave select pin.
			I2S_LRCK	I/O	I <sup>2</sup> S left right channel clock.
46			PE.6	I/O	General purpose digital I/O pin.
47	29	21	PE.5	I/O	General purpose digital I/O pin.
			PWM5	I/O	PWM5 output/Capture input.
			TM1_EXT	I	Timer1 external capture input pin.



Pin No.			Pin Name	Pin Type	Description
LQFP 100-pin	LQFP 64-pin	LQFP 48-pin			
48	30	22	PB.11	I/O	General purpose digital I/O pin.
			TM3	I/O	Timer3 event counter input / toggle output.
			PWM4	I/O	PWM4 output/Capture input.
49	31	23	PB.10	I/O	General purpose digital I/O pin.
			TM2	I/O	Timer2 event counter input / toggle output.
				SPI0_SS1	I/O
50	32	24	PB.9	I/O	General purpose digital I/O pin.
			TM1	I/O	Timer1 event counter input / toggle output.
			SPI1_SS1	I/O	2 <sup>nd</sup> SPI1 slave select pin.
51			PE.4	I/O	General purpose digital I/O pin.
52			PE.3	I/O	General purpose digital I/O pin.
53			PE.2	I/O	General purpose digital I/O pin.
54			PE.1	I/O	General purpose digital I/O pin.
			PWM7	I/O	PWM7 output/Capture input.
55			PE.0	I/O	General purpose digital I/O pin.
			PWM6	I/O	PWM6 output/Capture input.
56			PC.13	I/O	General purpose digital I/O pin.
			SPI1_MOSI1	I/O	2 <sup>nd</sup> SPI1 MOSI (Master Out, Slave In) pin.
57			PC.12	I/O	General purpose digital I/O pin.
			SPI1_MISO1	I/O	2 <sup>nd</sup> SPI1 MISO (Master In, Slave Out) pin.
58	33		PC.11	I/O	General purpose digital I/O pin.
			SPI1_MOSI0	I/O	1 <sup>st</sup> SPI1 MOSI (Master Out, Slave In) pin.
59	34		PC.10	I/O	General purpose digital I/O pin.
			SPI1_MISO0	I/O	1 <sup>st</sup> SPI1 MISO (Master In, Slave Out) pin.
60	35		PC.9	I/O	General purpose digital I/O pin.
			SPI1_CLK	I/O	SPI1 serial clock pin.
61	36		PC.8	I/O	General purpose digital I/O pin.
			SPI1_SS0	I/O	1 <sup>st</sup> SPI1 slave select pin.
62	37	25	PA.15	I/O	General purpose digital I/O pin.
			PWM3	I/O	PWM output/Capture input.



Pin No.			Pin Name	Pin Type	Description
LQFP 100-pin	LQFP 64-pin	LQFP 48-pin			
			I2S_MCLK	O	I <sup>2</sup> S master clock output pin.
			SC2_PWR	O	SmartCard2 power pin.
63	38	26	PA.14	I/O	General purpose digital I/O pin.
			PWM2	I/O	PWM2 output/Capture input.
			SC2_RST	O	SmartCard2 reset pin.
64	39	27	PA.13	I/O	General purpose digital I/O pin.
			PWM1	I/O	PWM1 output/Capture input.
			SC2_CLK	O	SmartCard2 clock pin.
65	40	28	PA.12	I/O	General purpose digital I/O pin.
			PWM0	I/O	PWM0 output/Capture input.
			SC2_DAT	O	SmartCard2 data pin.
66	41	29	ICE_DAT	I/O	Serial wire debugger data pin.
67	42	30	ICE_CLK	I	Serial wire debugger clock pin.
68			V <sub>DD</sub>	P	Power supply for I/O ports and LDO source for internal PLL and digital circuit.
69			V <sub>SS</sub>	P	Ground pin for digital circuit.
70	43	31	AV <sub>SS</sub>	AP	Ground pin for analog circuit.
			PA.0	I/O	General purpose digital I/O pin.
			ADC0	AI	ADC0 analog input.
71	44	32	SC0_PWR	O	SmartCard0 power pin.
			PA.1	I/O	General purpose digital I/O pin.
			ADC1	AI	ADC1 analog input.
72	45	33	SC0_RST	O	SmartCard0 reset pin.
			PA.2	I/O	General purpose digital I/O pin.
			ADC2	AI	ADC2 analog input.
73	46	34	SC0_CLK	O	SmartCard0 clock pin.
			PA.3	I/O	General purpose digital I/O pin.
			ADC3	AI	ADC3 analog input.
74	47	35	SC0_DAT	O	SmartCard0 data pin.
			PA.4	I/O	General purpose digital I/O pin.
			ADC4	AI	ADC4 analog input.
75	48	36	PA.4	I/O	General purpose digital I/O pin.
			ADC4	AI	ADC4 analog input.



Pin No.			Pin Name	Pin Type	Description
LQFP 100-pin	LQFP 64-pin	LQFP 48-pin			
			SC1_PWR	O	SmartCard1 power pin.
76	49	37	PA.5	I/O	General purpose digital I/O pin.
			ADC5	AI	ADC5 analog input.
			SC1_RST	O	SmartCard1 reset pin.
77	50	38	PA.6	I/O	General purpose digital I/O pin.
			ADC6	AI	ADC6 analog input.
			SC1_CLK	I/O	SmartCard1 clock pin.
78			PA.7	I/O	General purpose digital I/O pin.
			ADC7	AI	ADC7 analog input.
			SC1_DAT	O	SmartCard1 data pin.
			SPI2_SS1	I/O	2 <sup>nd</sup> SPI2 slave select pin.
79	51	39	V <sub>REF</sub>	AP	Voltage reference input for ADC.
80	52	40	AV <sub>DD</sub>	AP	Power supply for internal analog circuit.
81			PD.0	I/O	General purpose digital I/O pin.
			SPI2_SS0	I/O	1 <sup>st</sup> SPI2 slave select pin.
82			PD.1	I/O	General purpose digital I/O pin.
			SPI2_CLK	I/O	SPI2 serial clock pin.
83			PD.2	I/O	General purpose digital I/O pin.
			SPI2_MISO0	I/O	1 <sup>st</sup> SPI2 MISO (Master In, Slave Out) pin.
84			PD.3	I/O	General purpose digital I/O pin.
			SPI2_MOSI0	I/O	1 <sup>st</sup> SPI2 MOSI (Master Out, Slave In) pin.
85			PD.4	I/O	General purpose digital I/O pin.
			SPI2_MISO1	I/O	2 <sup>nd</sup> SPI2 MISO (Master In, Slave Out) pin.
86			PD.5	I/O	General purpose digital I/O pin.
			SPI2_MOSI1	I/O	2 <sup>nd</sup> SPI2 MOSI (Master Out, Slave In) pin.
87	53	41	PC.7	I/O	General purpose digital I/O pin.
			CMP0_N	AI	Comparator0 negative input pin.
			SC1_CD	I	SmartCard1 card detect pin.
88	54	42	PC.6	I/O	General purpose digital I/O pin.
			CMP0_P	AI	Comparator0 positive input pin.

Pin No.			Pin Name	Pin Type	Description
LQFP 100-pin	LQFP 64-pin	LQFP 48-pin			
			SC0_CD	I	SmartCard0 card detect pin.
89	55		PC.15	I/O	General purpose digital I/O pin.
			CMP1_N	AI	Comparator1 negative input pin.
90	56		PC.14	I/O	General purpose digital I/O pin.
			CMP1_P	AI	Comparator1 positive input pin.
91	57	43	PB.15	I/O	General purpose digital I/O pin.
			INT1	I	External interrupt1 input pin.
			TM0_EXT	I	Timer0 external capture input pin.
92	58	44	PF.0	I/O	General purpose digital I/O pin.
			XT1_OUT	O	External 4~24 MHz (high speed) crystal output pin.
93	59	45	PF.1	I/O	General purpose digital I/O pin.
			XT1_IN	I	External 4~24 MHz (high speed) crystal input pin.
94	60	46	nRESET	I	External reset input: active LOW, with an internal pull-up. Set this pin low reset chip to initial state.
95	61		V <sub>SS</sub>	P	Ground pin for digital circuit.
96	62		V <sub>DD</sub>	P	Power supply for I/O ports and LDO source for internal PLL and digital circuit.
97			PF.2	I/O	General purpose digital I/O pin.
			PS2_DAT	I/O	PS2 data pin.
98			PF.3	I/O	General purpose digital I/O pin.
			PS2_CLK	I/O	PS2 clock pin.
99	63	47	PV <sub>SS</sub>	P	PLL ground.
100	64	48	PB.8	I/O	General purpose digital I/O pin.
			STADC	I	ADC external trigger input.
			TM0	I/O	Timer0 event counter input / toggle output.
			CLKO	O	Frequency divider clock output pin.

**Note:** Pin Type I = Digital Input, O = Digital Output; AI = Analog Input; P = Power Pin; AP = Analog Power.

## 3.3.2 NuMicro™ NUC220 Pin Description

Pin No.			Pin Name	Pin Type	Description
LQFP 100-pin	LQFP 64-pin	LQFP 48-pin			
1			PE.15	I/O	General purpose digital I/O pin.
2			PE.14	I/O	General purpose digital I/O pin.
3			PE.13	I/O	General purpose digital I/O pin.
4	1		PB.14	I/O	General purpose digital I/O pin.
			INT0	I	External interrupt0 input pin.
			SPI3_SS1	I/O	2 <sup>nd</sup> SPI3 slave select pin.
5	2		PB.13	I/O	General purpose digital I/O pin.
			CMP1_O	O	Comparator1 output pin.
6	3	1	V <sub>BAT</sub>	P	Power supply by batteries for RTC.
7	4	2	X32_OUT	O	External 32.768 kHz (low speed) crystal output pin.
8	5	3	X32_IN	I	External 32.768 kHz (low speed) crystal input pin.
9	6	4	PA.11	I/O	General purpose digital I/O pin.
			I2C1_SCL	I/O	I <sup>2</sup> C1 clock pin.
10	7	5	PA.10	I/O	General purpose digital I/O pin.
			I2C1_SDA	I/O	I <sup>2</sup> C1 data input/output pin.
11	8	6	PA.9	I/O	General purpose digital I/O pin.
			I2C0_SCL	I/O	I <sup>2</sup> C0 clock pin.
12	9	7	PA.8	I/O	General purpose digital I/O pin.
			I2C0_SDA	I/O	I <sup>2</sup> C0 data input/output pin.
13			PD.8	I/O	General purpose digital I/O pin.
			SPI3_SS0	I/O	1 <sup>st</sup> SPI3 slave select pin.
14			PD.9	I/O	General purpose digital I/O pin.
			SPI3_CLK	I/O	SPI3 serial clock pin.
15			PD.10	I/O	General purpose digital I/O pin.
			SPI3_MISO0	I/O	1 <sup>st</sup> SPI3 MISO (Master In, Slave Out) pin.
16			PD.11	I/O	General purpose digital I/O pin.
			SPI3_MOSI0	I/O	1 <sup>st</sup> SPI3 MOSI (Master Out, Slave In) pin.
17			PD.12	I/O	General purpose digital I/O pin.
			SPI3_MISO1	I/O	2 <sup>nd</sup> SPI3 MISO (Master In, Slave Out) pin.



Pin No.			Pin Name	Pin Type	Description
LQFP 100-pin	LQFP 64-pin	LQFP 48-pin			
18			PD.13	I/O	General purpose digital I/O pin.
			SPI3_MOSI1	I/O	2 <sup>nd</sup> SPI3 MOSI (Master Out, Slave In) pin.
19	10	8	PB.4	I/O	General purpose digital I/O pin.
			UART1_RXD	I	Data receiver input pin for UART1.
20	11	9	PB.5	I/O	General purpose digital I/O pin.
			UART1_TXD	O	Data transmitter output pin for UART1.
21	12		PB.6	I/O	General purpose digital I/O pin.
			UART1_nRTS	O	Request to Send output pin for UART1.
22	13		PB.7	I/O	General purpose digital I/O pin.
			UART1_nCTS	I	Clear to Send input pin for UART1.
23	14	10	LDO_CAP	P	LDO output pin.
24	15	11	V <sub>DD</sub>	P	Power supply for I/O ports and LDO source for internal PLL and digital circuit.
25	16	12	V <sub>SS</sub>	P	Ground pin for digital circuit.
26			PE.8	I/O	General purpose digital I/O pin.
27			PE.7	I/O	General purpose digital I/O pin.
28	17	13	USB_VBUS	USB	Power supply from USB host or HUB.
29	18	14	USB_VDD33_CAP	USB	Internal power regulator output 3.3V decoupling pin.
30	19	15	USB_D-	USB	USB differential signal D-.
31	20	16	USB_D+	USB	USB differential signal D+.
32	21	17	PB.0	I/O	General purpose digital I/O pin.
			UART0_RXD	I	Data receiver input pin for UART0.
33	22	18	PB.1	I/O	General purpose digital I/O pin.
			UART0_TXD	O	Data transmitter output pin for UART0.
34	23	19	PB.2	I/O	General purpose digital I/O pin.
			UART0_nRTS	O	Request to Send output pin for UART0.
			TM2_EXT	I	Timer2 external capture input pin.
35	24	20	CMP0_O	O	Comparator0 output pin.
			PB.3	I/O	General purpose digital I/O pin.
			UART0_nCTS	I	Clear to Send input pin for UART0.





Pin No.			Pin Name	Pin Type	Description
LQFP 100-pin	LQFP 64-pin	LQFP 48-pin			
			TM3_EXT	I	Timer3 external capture input pin.
			SC2_CD	I	SmartCard2 card detect pin.
36			PD.6	I/O	General purpose digital I/O pin.
37			PD.7	I/O	General purpose digital I/O pin.
38			PD.14	I/O	General purpose digital I/O pin.
			UART2_RXD	I	Data receiver input pin for UART2.
39			PD.15	I/O	General purpose digital I/O pin.
			UART2_TXD	O	Data transmitter output pin for UART2.
40			PC.5	I/O	General purpose digital I/O pin.
			SPI0_MOSI1	I/O	2 <sup>nd</sup> SPI0 MOSI (Master Out, Slave In) pin.
41			PC.4	I/O	General purpose digital I/O pin.
			SPI0_MISO1	I/O	2 <sup>nd</sup> SPI0 MISO (Master In, Slave Out) pin.
42	25	21	PC.3	I/O	General purpose digital I/O pin.
			SPI0_MOSI0	I/O	1 <sup>st</sup> SPI0 MOSI (Master Out, Slave In) pin.
			I2S_DO	O	I <sup>2</sup> S data output.
43	26	22	PC.2	I/O	General purpose digital I/O pin.
			SPI0_MISO0	I/O	1 <sup>st</sup> SPI0 MISO (Master In, Slave Out) pin.
			I2S_DI	I	I <sup>2</sup> S data input.
44	27	23	PC.1	I/O	General purpose digital I/O pin.
			SPI0_CLK	I/O	SPI0 serial clock pin.
			I2S_BCLK	I/O	I <sup>2</sup> S bit clock pin.
45	28	24	PC.0	I/O	General purpose digital I/O pin.
			SPI0_SS0	I/O	1 <sup>st</sup> SPI0 slave select pin.
			I2S_LRCK	I/O	I <sup>2</sup> S left right channel clock.
46			PE.6	I/O	General purpose digital I/O pin.
47	29		PE.5	I/O	General purpose digital I/O pin.
			PWM5	I/O	PWM5 output/Capture input.
			TM1_EXT	I	Timer1 external capture input pin.
48	30		PB.11	I/O	General purpose digital I/O pin.

Pin No.			Pin Name	Pin Type	Description
LQFP 100-pin	LQFP 64-pin	LQFP 48-pin			
			TM3	I/O	Timer3 event counter input / toggle output.
			PWM4	I/O	PWM4 output/Capture input.
49	31		PB.10	I/O	General purpose digital I/O pin.
			TM2	I/O	Timer2 event counter input / toggle output.
	SPI0_SS1		I/O	2 <sup>nd</sup> SPI0 slave select pin.	
50	32		PB.9	I/O	General purpose digital I/O pin.
			TM1	I/O	Timer1 event counter input / toggle output.
	SPI1_SS1		I/O	2 <sup>nd</sup> SPI1 slave select pin.	
51			PE.4	I/O	General purpose digital I/O pin.
52			PE.3	I/O	General purpose digital I/O pin.
53			PE.2	I/O	General purpose digital I/O pin.
54			PE.1	I/O	General purpose digital I/O pin.
			PWM7	I/O	PWM7 output/Capture input.
55			PE.0	I/O	General purpose digital I/O pin.
			PWM6	I/O	PWM6 output/Capture input.
56			PC.13	I/O	General purpose digital I/O pin.
			SPI1_MOSI1	I/O	2 <sup>nd</sup> SPI1MOSI (Master Out, Slave In) pin.
57			PC.12	I/O	General purpose digital I/O pin.
			SPI1_MISO1	I/O	2 <sup>nd</sup> SPI1 MISO (Master In, Slave Out) pin.
58	33		PC.11	I/O	General purpose digital I/O pin.
			SPI1_MOSI0	I/O	1 <sup>st</sup> SPI1 MOSI (Master Out, Slave In) pin.
59	34		PC.10	I/O	General purpose digital I/O pin.
			SPI1_MISO0	I/O	1 <sup>st</sup> SPI1 MISO (Master In, Slave Out) pin.
60	35		PC.9	I/O	General purpose digital I/O pin.
			SPI1_CLK	I/O	SPI1 serial clock pin.
61	36		PC.8	I/O	General purpose digital I/O pin.
			SPI1_SS0	I/O	1 <sup>st</sup> SPI1 slave select pin.
62	37	25	PA.15	I/O	General purpose digital I/O pin.
			PWM3	I/O	PWM3 output/Capture input.
		I2S_MCLK	O	I <sup>2</sup> S master clock output pin.	

Pin No.			Pin Name	Pin Type	Description
LQFP 100-pin	LQFP 64-pin	LQFP 48-pin			
			SC2_PWR	<b>O</b>	SmartCard2 power pin.
63	38	26	PA.14	<b>I/O</b>	General purpose digital I/O pin.
			PWM2	<b>I/O</b>	PWM2 output/Capture input.
			SC2_RST	<b>O</b>	SmartCard2 reset pin.
64	39	27	PA.13	<b>I/O</b>	General purpose digital I/O pin.
			PWM1	<b>I/O</b>	PWM1 output/Capture input.
			SC2_CLK	<b>O</b>	SmartCard2 clock pin.
65	40	28	PA.12	<b>I/O</b>	General purpose digital I/O pin.
			PWM0	<b>I/O</b>	PWM0 output/Capture input.
			SC2_DAT	<b>O</b>	SmartCard2 data pin.
66	41	29	ICE_DAT	<b>I/O</b>	Serial wire debugger data pin.
67	42	30	ICE_CLK	<b>I</b>	Serial wire debugger clock pin.
68			V <sub>DD</sub>	<b>P</b>	Power supply for I/O ports and LDO source for internal PLL and digital circuit.
69			V <sub>SS</sub>	<b>P</b>	Ground pin for digital circuit.
70	43	31	AV <sub>SS</sub>	<b>AP</b>	Ground pin for analog circuit.
71	44	32	PA.0	<b>I/O</b>	General purpose digital I/O pin.
			ADC0	<b>AI</b>	ADC0 analog input.
			SC0_PWR	<b>O</b>	SmartCard0 power pin.
72	45	33	PA.1	<b>I/O</b>	General purpose digital I/O pin.
			ADC1	<b>AI</b>	ADC1 analog input.
			SC0_RST	<b>O</b>	SmartCard0 reset pin.
73	46	34	PA.2	<b>I/O</b>	General purpose digital I/O pin.
			ADC2	<b>AI</b>	ADC2 analog input.
			SC0_CLK	<b>O</b>	SmartCard0 clock pin.
74	47	35	PA.3	<b>I/O</b>	General purpose digital I/O pin.
			ADC3	<b>AI</b>	ADC3 analog input.
			SC0_DAT	<b>O</b>	SmartCard0 data pin.
75	48	36	PA.4	<b>I/O</b>	General purpose digital I/O pin.
			ADC4	<b>AI</b>	ADC4 analog input.
			SC1_PWR	<b>O</b>	SmartCard1 power pin.



Pin No.			Pin Name	Pin Type	Description
LQFP 100-pin	LQFP 64-pin	LQFP 48-pin			
76	49	37	PA.5	I/O	General purpose digital I/O pin.
			ADC5	AI	ADC5 analog input.
				SC1_RST	O
77	50	38	PA.6	I/O	General purpose digital I/O pin.
			ADC6	AI	ADC6 analog input.
				SC1_CLK	I/O
78			PA.7	I/O	General purpose digital I/O pin.
			ADC7	AI	ADC7 analog input.
			SC1_CLK	O	SmartCard1 clock pin.
			SPI2_SS1	I/O	2 <sup>nd</sup> SPI2 slave select pin.
79	51	39	V <sub>REF</sub>	AP	Voltage reference input for ADC.
80	52	40	AV <sub>DD</sub>	AP	Power supply for internal analog circuit.
81			PD.0	I/O	General purpose digital I/O pin.
			SPI2_SS0	I/O	1 <sup>st</sup> SPI2 slave select pin.
82			PD.1	I/O	General purpose digital I/O pin.
			SPI2_CLK	I/O	SPI2 serial clock pin.
83			PD.2	I/O	General purpose digital I/O pin.
			SPI2_MISO0	I/O	1 <sup>st</sup> SPI2 MISO (Master In, Slave Out) pin.
84			PD.3	I/O	General purpose digital I/O pin.
			SPI2_MOSI0	I/O	1 <sup>st</sup> SPI2 MOSI (Master Out, Slave In) pin.
85			PD.4	I/O	General purpose digital I/O pin.
			SPI2_MISO1	I/O	2 <sup>nd</sup> SPI2 MISO (Master In, Slave Out) pin.
86			PD.5	I/O	General purpose digital I/O pin.
			SPI2_MOSI1	I/O	2 <sup>nd</sup> SPI2 MOSI (Master Out, Slave In) pin.
87	53	41	PC.7	I/O	General purpose digital I/O pin.
			CMP0_N	AI	Comparator0 negative input pin.
				SC1_CD	I
88	54	42	PC.6	I/O	General purpose digital I/O pin.
			CMP0_P	AI	Comparator0 positive input pin.
			SC0_CD	I	SmartCard0 card detect pin.

Pin No.			Pin Name	Pin Type	Description
LQFP 100-pin	LQFP 64-pin	LQFP 48-pin			
89	55		PC.15	I/O	General purpose digital I/O pin.
			CMP1_N	AI	Comparator1 negative input pin.
90	56		PC.14	I/O	General purpose digital I/O pin.
			CMP1_P	AI	Comparator1 positive input pin.
91	57	43	PB.15	I/O	General purpose digital I/O pin.
			INT1	I	External interrupt1 input pin.
			TM0_EXT	I	Timer 0 external capture input pin.
92	58	44	PF.0	I/O	General purpose digital I/O pin.
			XT1_OUT	O	External 4~24 MHz (high speed) crystal output pin.
93	59	45	PF.1	I/O	General purpose digital I/O pin.
			XT1_IN	I	External 4~24 MHz (high speed) crystal input pin.
94	60	46	nRESET	I	External reset input: active LOW, with an internal pull-up. Set this pin low reset chip to initial state.
95	61		V <sub>SS</sub>	P	Ground pin for digital circuit.
96	62		V <sub>DD</sub>	P	Power supply for I/O ports and LDO source for internal PLL and digital circuit.
97			PF.2	I/O	General purpose digital I/O pin.
			PS2_DAT	I/O	PS2 data pin.
98			PF.3	I/O	General purpose digital I/O pin.
			PS2_CLK	I/O	PS2 clock pin.
99	63	47	PV <sub>SS</sub>	P	PLL ground.
100	64	48	PB.8	I/O	General purpose digital I/O pin.
			STADC	I	ADC external trigger input.
			TM0	I/O	Timer0 event counter input / toggle output.
			CLKO	O	Frequency divider clock output pin.

Note: Pin Type I = Digital Input, O = Digital Output; AI = Analog Input; P = Power Pin; AP = Analog Power.

4 BLOCK DIAGRAM

4.1 NuMicro™ NUC200 Block Diagram

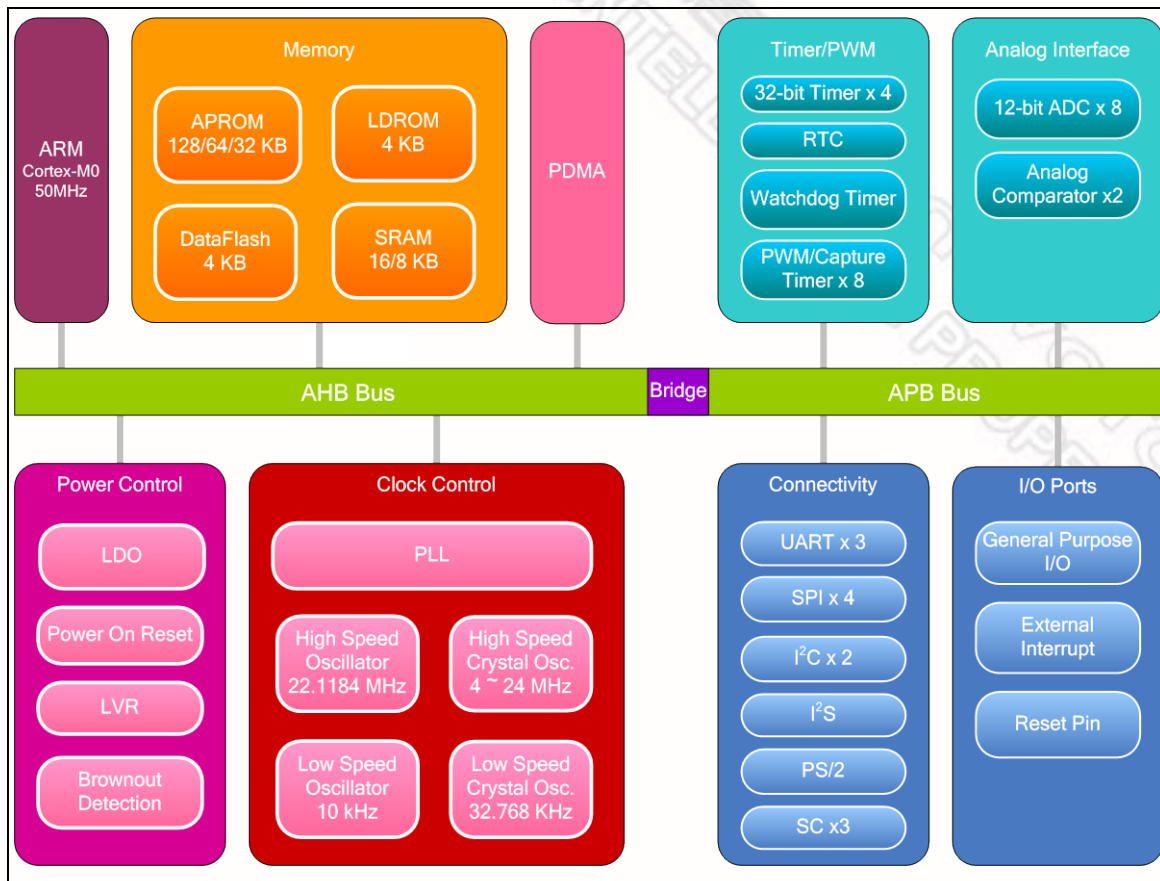

Figure 4-1 NuMicro™ NUC200 Block Diagram

4.2 NuMicro™ NUC220 Block Diagram

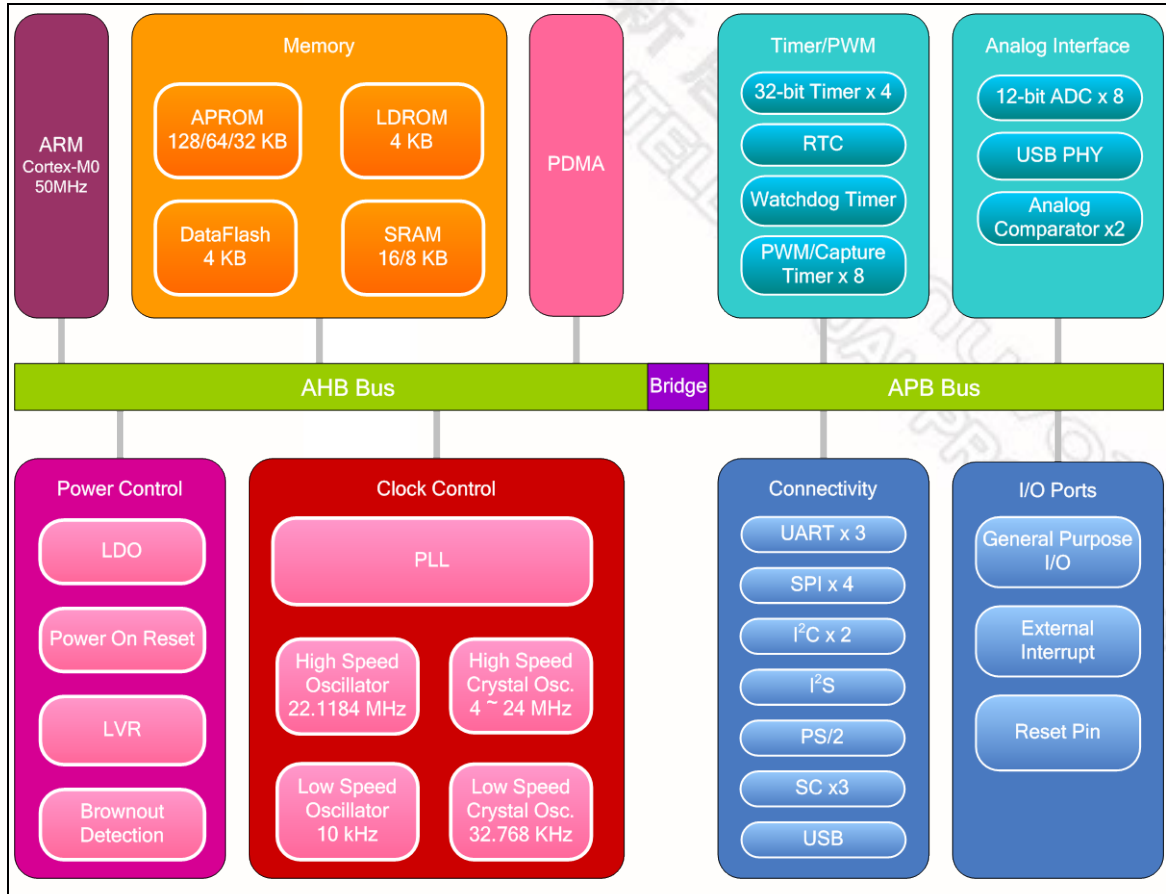

Figure 4-2 NuMicro™ NUC220 Block Diagram

## 5 FUNCTIONAL DESCRIPTION

### 5.1 ARM® Cortex™-M0 Core

The Cortex™-M0 processor is a configurable, multistage, 32-bit RISC processor, which has an AMBA AHB-Lite interface and includes an NVIC component. It also has optional hardware debug functionality. The processor can execute Thumb code and is compatible with other Cortex™-M profile processor. The profile supports two modes -Thread mode and Handler mode. Handler mode is entered as a result of an exception. An exception return can only be issued in Handler mode. Thread mode is entered on Reset, and can be entered as a result of an exception return. Figure 5-1 shows the functional controller of processor.

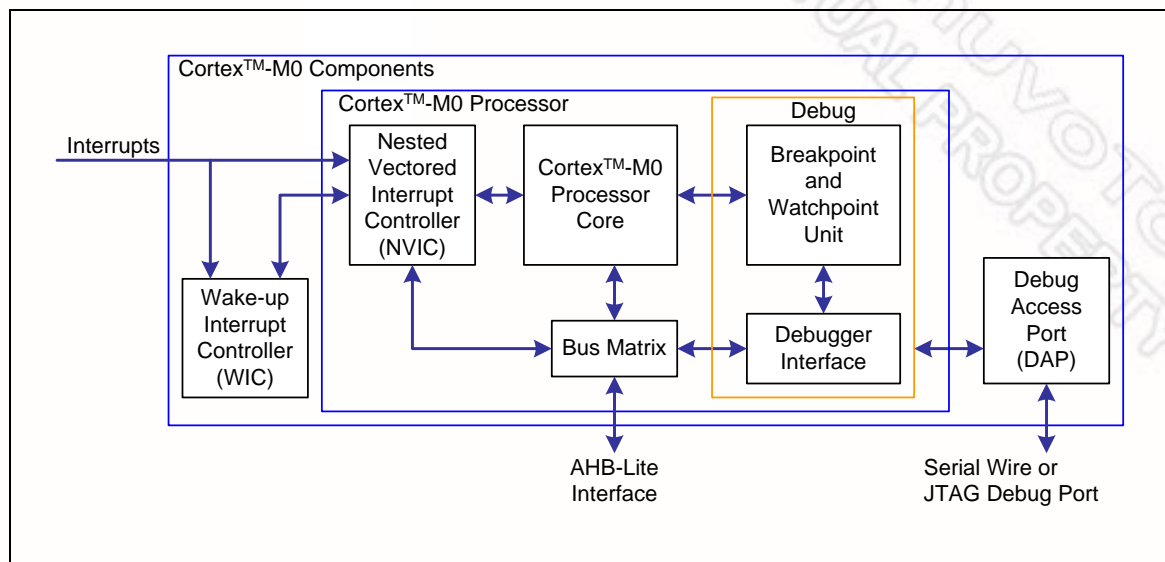

Figure 5-1 Functional Controller Diagram

The implemented device provides the following components and features:

- A low gate count processor:
  - ◆ ARMv6-M Thumb® instruction set
  - ◆ Thumb-2 technology
  - ◆ ARMv6-M compliant 24-bit SysTick timer
  - ◆ A 32-bit hardware multiplier
  - ◆ System interface supported with little-endian data accesses
  - ◆ Ability to have deterministic, fixed-latency, interrupt handling
  - ◆ Load/store-multiples and multicycle-multiples that can be abandoned and restarted to facilitate rapid interrupt handling
  - ◆ C Application Binary Interface compliant exception model. This is the ARMv6-M, C Application Binary Interface (C-ABI) compliant exception model that enables the use of pure C functions as interrupt handlers
  - ◆ Low Power Sleep mode entry using Wait For Interrupt (WFI), Wait For Event (WFE) instructions, or the return from interrupt sleep-on-exit feature



- NVIC:
  - ◆ 32 external interrupt inputs, each with four levels of priority
  - ◆ Dedicated Non-maskable Interrupt (NMI) input
  - ◆ Supports for both level-sensitive and pulse-sensitive interrupt lines
  - ◆ Supports Wake-up Interrupt Controller (WIC) and, providing Ultra-low Power Sleep mode
- Debug support:
  - ◆ Four hardware breakpoints
  - ◆ Two watchpoints
  - ◆ Program Counter Sampling Register (PCSR) for non-intrusive code profiling
  - ◆ Single step and vector catch capabilities
- Bus interfaces:
  - ◆ Single 32-bit AMBA-3 AHB-Lite system interface that provides simple integration to all system peripherals and memory
  - ◆ Single 32-bit slave port that supports the DAP (Debug Access Port).

## 5.2 System Manager

### 5.2.1 Overview

System management includes the following sections:

- System Resets
- System Memory Map
- System management registers for Part Number ID, chip reset and on-chip controllers reset , multi-functional pin control
- System Timer (SysTick)
- Nested Vectored Interrupt Controller (NVIC)
- System Control registers

### 5.2.2 System Reset

The system reset can be issued by one of the following listed events. For these reset event flags can be read by RSTSRC register.

- Power-on Reset
- Low level on the nRESET pin
- Watchdog Time-out Reset
- Low Voltage Reset
- Brown-out Detector Reset
- CPU Reset
- System Reset

System Reset and Power-on Reset all reset the whole chip including all peripherals. The difference between System Reset and Power-on Reset is external crystal circuit and ISPCON.BS bit. System Reset does not reset external crystal circuit and ISPCON.BS bit, but Power-on Reset does.

### 5.2.3 System Power Distribution

In this chip, the power distribution is divided into four segments.

- Analog power from  $AV_{DD}$  and  $AV_{SS}$  provides the power for analog components operation.
- Digital power from  $V_{DD}$  and  $V_{SS}$  supplies the power to the internal regulator which provides a fixed 1.8 V power for digital operation and I/O pins.
- USB transceiver power from  $USB\_VBUS$  offers the power for operating the USB transceiver.
- Battery power from  $V_{BAT}$  supplies the RTC and external 32.768 kHz crystal.

The outputs of internal voltage regulators,  $LDO\_CAP$  and  $USB\_VDD33\_CAP$ , require an external capacitor which should be located close to the corresponding pin. Analog power ( $AV_{DD}$ ) should be the same voltage level of the digital power ( $V_{DD}$ ). Figure 5-2 shows the power distribution of NuMicro™ NUC200; Figure 5-3 shows the power distribution of NuMicro™ NUC220.

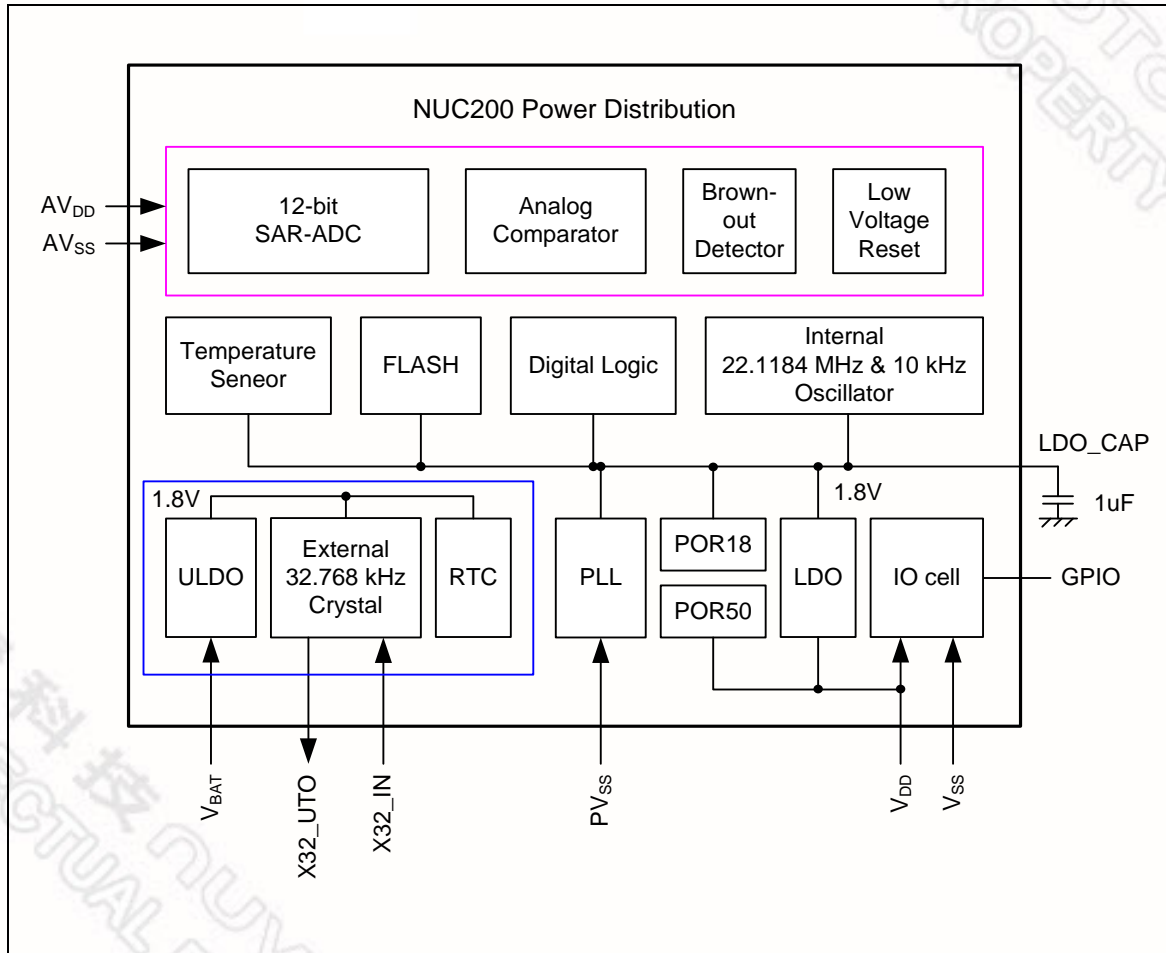

Figure 5-2 NuMicro™ NUC200 Power Distribution Diagram

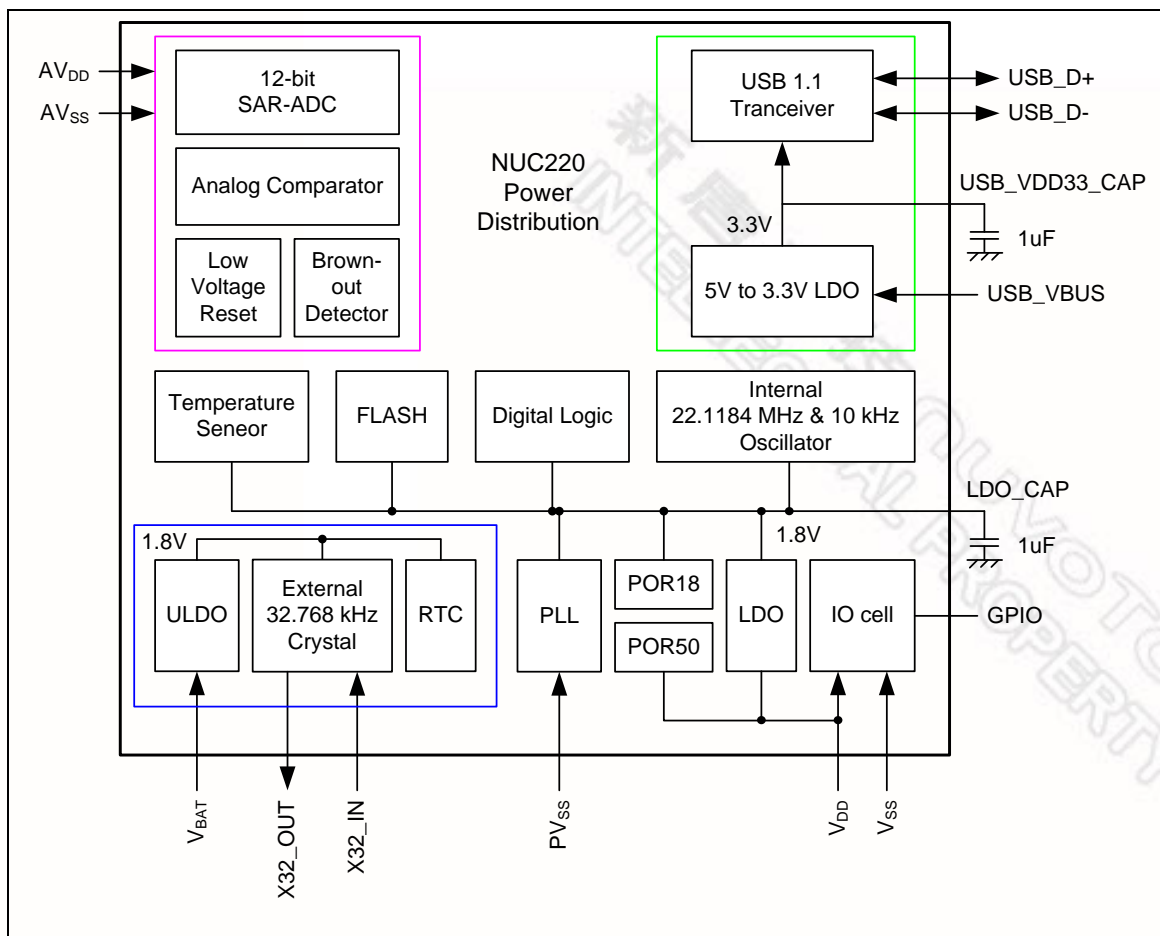

Figure 5-3 NuMicro™ NUC220 Power Distribution Diagram

### 5.2.4 System Memory Map

The NuMicro™ NUC200 Series provides 4G-byte addressing space. The memory locations assigned to each on-chip controllers are shown in the following table. The detailed register definition, memory space, and programming detailed will be described in the following sections for each on-chip peripheral. The NuMicro™ NUC200 Series only supports little-endian data format.

Address Space	Token	Controllers
<b>Flash and SRAM Memory Space</b>		
0x0000_0000 – 0x0001_FFFF	FLASH_BA	FLASH Memory Space (128 KB)
0x2000_0000 – 0x2000_3FFF	SRAM_BA	SRAM Memory Space (16 KB)
<b>AHB Controllers Space (0x5000_0000 – 0x501F_FFFF)</b>		
0x5000_0000 – 0x5000_01FF	GCR_BA	System Global Control Registers
0x5000_0200 – 0x5000_02FF	CLK_BA	Clock Control Registers
0x5000_0300 – 0x5000_03FF	INT_BA	Interrupt Multiplexer Control Registers
0x5000_4000 – 0x5000_7FFF	GPIO_BA	GPIO Control Registers
0x5000_8000 – 0x5000_BFFF	PDMA_BA	Peripheral DMA Control Registers
0x5000_C000 – 0x5000_FFFF	FMC_BA	Flash Memory Control Registers
<b>APB1 Controllers Space (0x4000_0000 ~ 0x400F_FFFF)</b>		
0x4000_4000 – 0x4000_7FFF	WDT_BA	Watchdog Timer Control Registers
0x4000_8000 – 0x4000_BFFF	RTC_BA	Real Time Clock (RTC) Control Register
0x4001_0000 – 0x4001_3FFF	TMR01_BA	Timer0/Timer1 Control Registers
0x4002_0000 – 0x4002_3FFF	I2C0_BA	I <sup>2</sup> C0 Interface Control Registers
0x4003_0000 – 0x4003_3FFF	SPI0_BA	SPI0 with master/slave function Control Registers
0x4003_4000 – 0x4003_7FFF	SPI1_BA	SPI1 with master/slave function Control Registers
0x4004_0000 – 0x4004_3FFF	PWMA_BA	PWM0/1/2/3 Control Registers
0x4005_0000 – 0x4005_3FFF	UART0_BA	UART0 Control Registers
0x4006_0000 – 0x4006_3FFF	USBD_BA	USB 2.0 FS device Controller Registers
0x400D_0000 – 0x400D_3FFF	ACMP_BA	Analog Comparator Control Registers
0x400E_0000 – 0x400E_FFFF	ADC_BA	Analog-Digital-Converter (ADC) Control Registers
<b>APB2 Controllers Space (0x4010_0000 ~ 0x401F_FFFF)</b>		

0x4010_0000 – 0x4010_3FFF	PS2_BA	PS/2 Interface Control Registers
0x4011_0000 – 0x4011_3FFF	TMR23_BA	Timer2/Timer3 Control Registers
0x4012_0000 – 0x4012_3FFF	I2C1_BA	I <sup>2</sup> C1 Interface Control Registers
0x4013_0000 – 0x4013_3FFF	SPI2_BA	SPI2 with master/slave function Control Registers
0x4013_4000 – 0x4013_7FFF	SPI3_BA	SPI3 with master/slave function Control Registers
0x4014_0000 – 0x4014_3FFF	PWMB_BA	PWM4/5/6/7 Control Registers
0x4015_0000 – 0x4015_3FFF	UART1_BA	UART1 Control Registers
0x4015_4000 – 0x4015_7FFF	UART2_BA	UART2 Control Registers
0x4019_0000 – 0x4019_3FFF	SC0_BA	SC0 Control Registers
0x4019_4000 – 0x4019_7FFF	SC1_BA	SC1 Control Registers
0x4019_8000 – 0x4019_BFFF	SC2_BA	SC2 Control Registers
0x401A_0000 – 0x401A_3FFF	I2S_BA	I <sup>2</sup> S Interface Control Registers
<b>System Controllers Space (0xE000_E000 ~ 0xE000_EFFF)</b>		
0xE000_E010 – 0xE000_E0FF	SYST_BA	System Timer Control Registers
0xE000_E100 – 0xE000_ECFF	NVIC_BA	External Interrupt Controller Control Registers
0xE000_ED00 – 0xE000_ED8F	SCS_BA	System Control Registers

Table 5-1 Address Space Assignments for On-Chip Controllers

### 5.2.5 System Timer (SysTick)

The Cortex™-M0 includes an integrated system timer, SysTick, which provides a simple, 24-bit clear-on-write, decrementing, wrap-on-zero counter with a flexible control mechanism. The counter can be used as a Real Time Operating System (RTOS) tick timer or as a simple counter.

When system timer is enabled, it will count down from the value in the SysTick Current Value Register (SYST\_CVR) to 0, and reload (wrap) to the value in the SysTick Reload Value Register (SYST\_RVR) on the next clock cycle, then decrement on subsequent clocks. When the counter transitions to 0, the COUNTFLAG status bit is set. The COUNTFLAG bit clears on reads.

The SYST\_CVR value is UNKNOWN on reset. Software should write to the register to clear it to 0 before enabling the feature. This ensures the timer will count from the SYST\_RVR value rather than an arbitrary value when it is enabled.

If the SYST\_RVR is 0, the timer will be maintained with a current value of 0 after it is reloaded with this value. This mechanism can be used to disable the feature independently from the timer enable bit.

For more detailed information, please refer to the “ARM® Cortex™-M0 Technical Reference Manual” and “ARM® v6-M Architecture Reference Manual”.

### 5.2.6 Nested Vectored Interrupt Controller (NVIC)

The Cortex™-M0 provides an interrupt controller as an integral part of the exception mode, named as “Nested Vectored Interrupt Controller (NVIC)”, which is closely coupled to the processor kernel and provides following features:

- Nested and Vectored interrupt support
- Automatic processor state saving and restoration
- Reduced and deterministic interrupt latency

The NVIC prioritizes and handles all supported exceptions. All exceptions are handled in “Handler Mode”. This NVIC architecture supports 32 (IRQ[31:0]) discrete interrupts with 4 levels of priority. All of the interrupts and most of the system exceptions can be configured to different priority levels. When an interrupt occurs, the NVIC will compare the priority of the new interrupt to the current running one’s priority. If the priority of the new interrupt is higher than the current one, the new interrupt handler will override the current handler.

When an interrupt is accepted, the starting address of the interrupt service routine (ISR) is fetched from a vector table in memory. There is no need to determine which interrupt is accepted and branch to the starting address of the correlated ISR by software. While the starting address is fetched, NVIC will also automatically save processor state including the registers “PC, PSR, LR, R0~R3, R12” to the stack. At the end of the ISR, the NVIC will restore the mentioned registers from stack and resume the normal execution. Thus it will take less and deterministic time to process the interrupt request.

The NVIC supports “Tail Chaining” which handles back-to-back interrupts efficiently without the overhead of states saving and restoration and therefore reduces delay time in switching to pending ISR at the end of current ISR. The NVIC also supports “Late Arrival” which improves the efficiency of concurrent ISRs. When a higher priority interrupt request occurs before the current ISR starts to execute (at the stage of state saving and starting address fetching), the NVIC will give priority to the higher one without delay penalty. Thus it advances the real-time capability.

For more detailed information, please refer to the “ARM® Cortex™-M0 Technical Reference Manual” and “ARM® v6-M Architecture Reference Manual”.



### 5.2.6.1 Exception Model and System Interrupt Map

The following table lists the exception model supported by NuMicro™ NUC200 Series. Software can set four levels of priority on some of these exceptions as well as on all interrupts. The highest user-configurable priority is denoted as “0” and the lowest priority is denoted as “3”. The default priority of all the user-configurable interrupts is “0”. Note that priority “0” is treated as the fourth priority on the system, after three system exceptions “Reset”, “NMI” and “Hard Fault”.

Exception Name	Vector Number	Priority
Reset	1	-3
NMI	2	-2
Hard Fault	3	-1
Reserved	4 ~ 10	Reserved
SVCall	11	Configurable
Reserved	12 ~ 13	Reserved
PendSV	14	Configurable
SysTick	15	Configurable
Interrupt (IRQ0 ~ IRQ31)	16 ~ 47	Configurable

Table 5-2 Exception Model

Vector Number	Interrupt Number (Bit in Interrupt Registers)	Interrupt Name	Source IP	Interrupt Description
0 ~ 15	-	-	-	System exceptions
16	0	<b>BOD_INT</b>	Brown-out	Brown-out low voltage detected interrupt
17	1	<b>WDT_INT</b>	WDT	Watchdog Timer interrupt
18	2	<b>EINT0</b>	GPIO	External signal interrupt from PB.14 pin
19	3	<b>EINT1</b>	GPIO	External signal interrupt from PB.15 pin
20	4	<b>GPAB_INT</b>	GPIO	External signal interrupt from PA[15:0]/PB[13:0]
21	5	<b>GPCDEF_INT</b>	GPIO	External interrupt from PC[15:0]/PD[15:0]/PE[15:0]/PF[3:0]
22	6	<b>PWMA_INT</b>	PWM0~3	PWM0, PWM1, PWM2 and PWM3 interrupt
23	7	<b>PWMB_INT</b>	PWM4~7	PWM4, PWM5, PWM6 and PWM7 interrupt
24	8	<b>TMR0_INT</b>	TMR0	Timer 0 interrupt
25	9	<b>TMR1_INT</b>	TMR1	Timer 1 interrupt
26	10	<b>TMR2_INT</b>	TMR2	Timer 2 interrupt

27	11	<b>TMR3_INT</b>	TMR3	Timer 3 interrupt
28	12	<b>UART02_INT</b>	UART0/2	UART0 and UART2 interrupt
29	13	<b>UART1_INT</b>	UART1	UART1 interrupt
30	14	<b>SPI0_INT</b>	SPI0	SPI0 interrupt
31	15	<b>SPI1_INT</b>	SPI1	SPI1 interrupt
32	16	<b>SPI2_INT</b>	SPI2	SPI2 interrupt
33	17	<b>SPI3_INT</b>	SPI3	SPI3 interrupt
34	18	<b>I2C0_INT</b>	I <sup>2</sup> C0	I <sup>2</sup> C0 interrupt
35	19	<b>I2C1_INT</b>	I <sup>2</sup> C1	I <sup>2</sup> C1 interrupt
36	20	<b>Reserved</b>	-	-
37	21	<b>Reserved</b>	-	-
38	22	<b>SC012_INT</b>	SC0/1/2	SC0, SC1 and SC2 interrupt
39	23	<b>USB_INT</b>	USBD	USB 2.0 FS Device interrupt
40	24	<b>PS2_INT</b>	PS/2	PS/2 interrupt
41	25	<b>ACMP_INT</b>	ACMP	Analog Comparator-0 or Comaprator-1 interrupt
42	26	<b>PDMA_INT</b>	PDMA	PDMA interrupt
43	27	<b>I2S_INT</b>	I <sup>2</sup> S	I <sup>2</sup> S interrupt
44	28	<b>PWRWU_INT</b>	CLKC	Clock controller interrupt for chip wake-up from power-down state
45	29	<b>ADC_INT</b>	ADC	ADC interrupt
46	30	<b>IRCT_INT</b>	IRC	IRC TRIM interrupt
47	31	<b>RTC_INT</b>	RTC	Real time clock interrupt

Table 5-3 System Interrupt Map

### 5.2.6.2 Vector Table

When an interrupt is accepted, the processor will automatically fetch the starting address of the interrupt service routine (ISR) from a vector table in memory. For ARMv6-M, the vector table base address is fixed at 0x00000000. The vector table contains the initialization value for the stack pointer on reset, and the entry point addresses for all exception handlers. The vector number on previous page defines the order of entries in the vector table associated with exception handler entry as illustrated in previous section.

Vector Table Word Offset	Description
0	SP_main – The Main stack pointer
Vector Number	Exception Entry Pointer using that Vector Number

Table 5-4 Vector Table Format

### 5.2.6.3 Operation Description

NVIC interrupts can be enabled and disabled by writing to their corresponding Interrupt Set-Enable or Interrupt Clear-Enable register bit-field. The registers use a write-1-to-enable and write-1-to-clear policy, both registers reading back the current enabled state of the corresponding interrupts. When an interrupt is disabled, interrupt assertion will cause the interrupt to become Pending, however, the interrupt will not be activated. If an interrupt is Active when it is disabled, it remains in its Active state until cleared by reset or an exception return. Clearing the enable bit prevents new activations of the associated interrupt.

NVIC interrupts can be pended/un-pended using a complementary pair of registers to those used to enable/disable the interrupts, named the Set-Pending Register and Clear-Pending Register respectively. The registers use a write-1-to-enable and write-1-to-clear policy, both registers reading back the current pended state of the corresponding interrupts. The Clear-Pending Register has no effect on the execution status of an Active interrupt.

NVIC interrupts are prioritized by updating an 8-bit field within a 32-bit register (each register supporting four interrupts).

The general registers associated with the NVIC are all accessible from a block of memory in the System Control Space and will be described in next section.

## 5.2.6.4 Interrupt Source Register Map

Besides the interrupt control registers associated with the NVIC, the NuMicro™ NUC200 Series also implements some specific control registers to facilitate the interrupt functions, including “interrupt source identification”, “NMI source selection” and “interrupt test mode”, which are described below.

R: read only, W: write only, R/W: both read and write

Register	Offset	R/W	Description	Reset Value
<b>INT Base Address:</b>				
<b>INT_BA = 0x5000_0300</b>				
IRQ0_SRC	INT_BA+0x00	R	IRQ0 (BOD) interrupt source identity	0xFFFF_FFFF
IRQ1_SRC	INT_BA+0x04	R	IRQ1 (WDT) interrupt source identity	0xFFFF_FFFF
IRQ2_SRC	INT_BA+0x08	R	IRQ2 (EINT0) interrupt source identity	0xFFFF_FFFF
IRQ3_SRC	INT_BA+0x0C	R	IRQ3 (EINT1) interrupt source identity	0xFFFF_FFFF
IRQ4_SRC	INT_BA+0x10	R	IRQ4 (GPA/GPB) interrupt source identity	0xFFFF_FFFF
IRQ5_SRC	INT_BA+0x14	R	IRQ5 (GPC/GPD/GPE/GPF) interrupt source identity	0xFFFF_FFFF
IRQ6_SRC	INT_BA+0x18	R	IRQ6 (PWMA) interrupt source identity	0xFFFF_FFFF
IRQ7_SRC	INT_BA+0x1C	R	IRQ7 (PWMB) interrupt source identity	0xFFFF_FFFF
IRQ8_SRC	INT_BA+0x20	R	IRQ8 (TMR0) interrupt source identity	0xFFFF_FFFF
IRQ9_SRC	INT_BA+0x24	R	IRQ9 (TMR1) interrupt source identity	0xFFFF_FFFF
IRQ10_SRC	INT_BA+0x28	R	IRQ10 (TMR2) interrupt source identity	0xFFFF_FFFF
IRQ11_SRC	INT_BA+0x2C	R	IRQ11 (TMR3) interrupt source identity	0xFFFF_FFFF
IRQ12_SRC	INT_BA+0x30	R	IRQ12 (UART0/UART2) interrupt source identity	0xFFFF_FFFF
IRQ13_SRC	INT_BA+0x34	R	IRQ13 (UART1) interrupt source identity	0xFFFF_FFFF
IRQ14_SRC	INT_BA+0x38	R	IRQ14 (SPI0) interrupt source identity	0xFFFF_FFFF
IRQ15_SRC	INT_BA+0x3C	R	IRQ15 (SPI1) interrupt source identity	0xFFFF_FFFF
IRQ16_SRC	INT_BA+0x40	R	IRQ16 (SPI2) interrupt source identity	0xFFFF_FFFF
IRQ17_SRC	INT_BA+0x44	R	IRQ17 (SPI3) interrupt source identity	0xFFFF_FFFF
IRQ18_SRC	INT_BA+0x48	R	IRQ18 (I <sup>2</sup> C0) interrupt source identity	0xFFFF_FFFF
IRQ19_SRC	INT_BA+0x4C	R	IRQ19 (I <sup>2</sup> C1) interrupt source identity	0xFFFF_FFFF
IRQ20_SRC	INT_BA+0x50	R	Reserved	0xFFFF_FFFF
IRQ21_SRC	INT_BA+0x54	R	Reserved	0xFFFF_FFFF
IRQ22_SRC	INT_BA+0x58	R	IRQ22 (SC0/SC1/SC2) interrupt source identity	0xFFFF_FFFF

<b>IRQ23_SRC</b>	INT_BA+0x5C	R	IRQ23 (USB) interrupt source identity	0xFFFF_FFFF
<b>IRQ24_SRC</b>	INT_BA+0x60	R	IRQ24 (PS/2) interrupt source identity	0xFFFF_FFFF
<b>IRQ25_SRC</b>	INT_BA+0x64	R	IRQ25 (ACMP) interrupt source identity	0xFFFF_FFFF
<b>IRQ26_SRC</b>	INT_BA+0x68	R	IRQ26 (PDMA) interrupt source identity	0xFFFF_FFFF
<b>IRQ27_SRC</b>	INT_BA+0x6C	R	IRQ27 (I <sup>2</sup> S) interrupt source identity	0xFFFF_FFFF
<b>IRQ28_SRC</b>	INT_BA+0x70	R	IRQ28 (PWRWU) interrupt source identity	0xFFFF_FFFF
<b>IRQ29_SRC</b>	INT_BA+0x74	R	IRQ29 (ADC) interrupt source identity	0xFFFF_FFFF
<b>IRQ30_SRC</b>	INT_BA+0x78	R	IRQ30 (IRCT) interrupt source identity	0xFFFF_FFFF
<b>IRQ31_SRC</b>	INT_BA+0x7C	R	IRQ31 (RTC) interrupt source identity	0xFFFF_FFFF
<b>NMI_SEL</b>	INT_BA+0x80	R/W	NMI source interrupt select control register	0x0000_0000
<b>MCU_IRQ</b>	INT_BA+0x84	R/W	MCU interrupt request source register	0x0000_0000

### 5.2.7 System Control (SCS)

The Cortex™-M0 status and operating mode control are managed by System Control Registers. Including CPUID, Cortex™-M0 interrupt priority and Cortex™-M0 power management can be controlled through these system control registers

For more detailed information, please refer to the “ARM® Cortex™-M0 Technical Reference Manual” and “ARM® v6-M Architecture Reference Manual”.

## 5.3 Clock Controller

### 5.3.1 Overview

The clock controller generates clocks for the whole chip, including system clocks and all peripheral clocks. The clock controller also implements the power control function with the individually clock ON/OFF control, clock source selection and clock divider. The chip enters Power-down mode when Cortex™-M0 core executes the WFI instruction only if the PWR\_DOWN\_EN (PWRCON[7]) bit and PD\_WAIT\_CPU (PWRCON[8]) bit are both set to 1. After that, chip enters Power-down mode and waits for wake-up interrupt source triggered to exit Power-down mode. In Power-down mode, the clock controller turns off the external 4~24 MHz high speed crystal and internal 22.1184 MHz high speed oscillator to reduce the overall system power consumption.

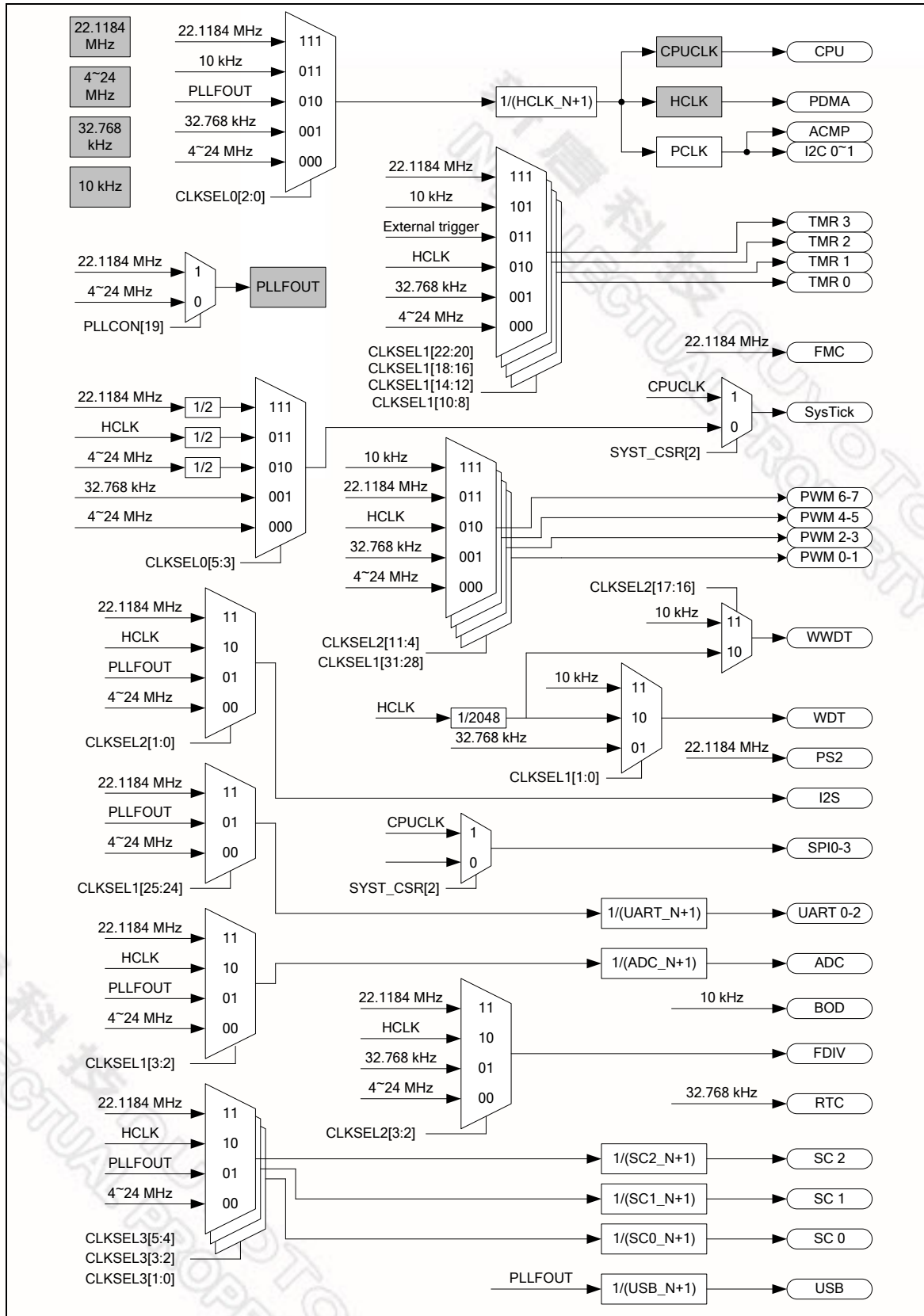

Figure 5-4 Clock Generator Global View Diagram

### 5.3.2 Clock Generator

The clock generator consists of 5 clock sources as listed below:

- One external 32.768 kHz low speed crystal
- One external 4~24 MHz high speed crystal
- One programmable PLL FOUT (PLL source consists of external 4~24 MHz high speed crystal and internal 22.1184 MHz high speed oscillator)
- One internal 22.1184 MHz high speed oscillator
- One internal 10 kHz low speed oscillator

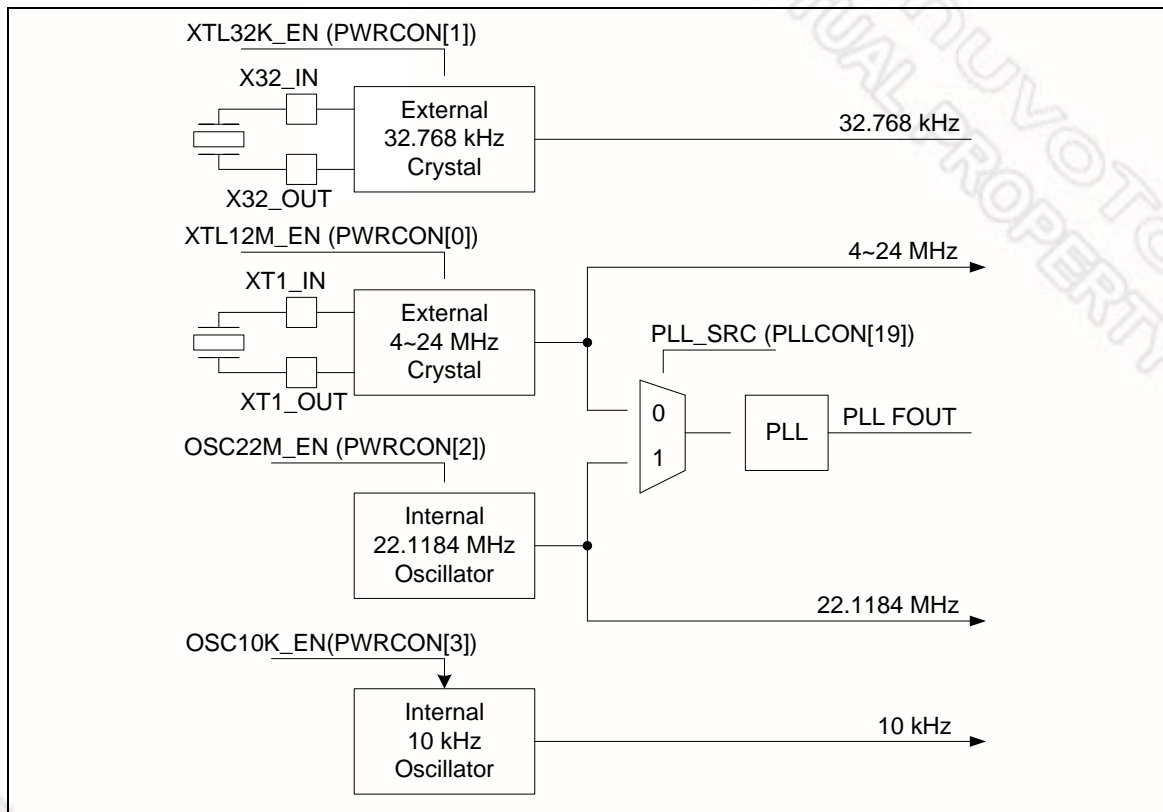

Figure 5-5 Clock Generator Block Diagram



### 5.3.3 System Clock and SysTick Clock

The system clock has 5 clock sources which were generated from clock generator block. The clock source switch depends on the register HCLK\_S (CLKSEL0[2:0]). The block diagram is shown in Figure 5-6.

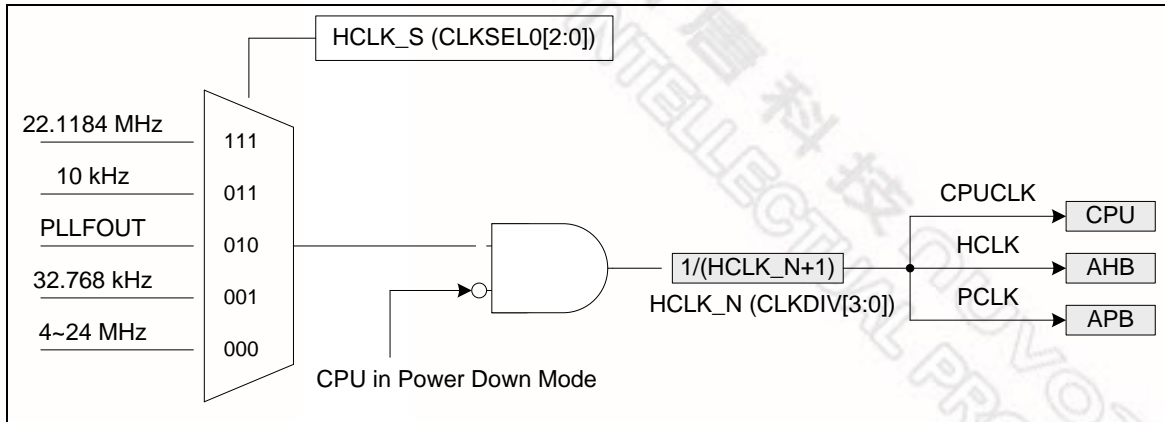

Figure 5-6 System Clock Block Diagram

The clock source of SysTick in Cortex™-M0 core can use CPU clock or external clock (SYST\_CSR[2]). If using external clock, the SysTick clock (STCLK) has 5 clock sources. The clock source switch depends on the setting of the register STCLK\_S (CLKSEL0[5:3]). The block diagram is shown in Figure 5-7.

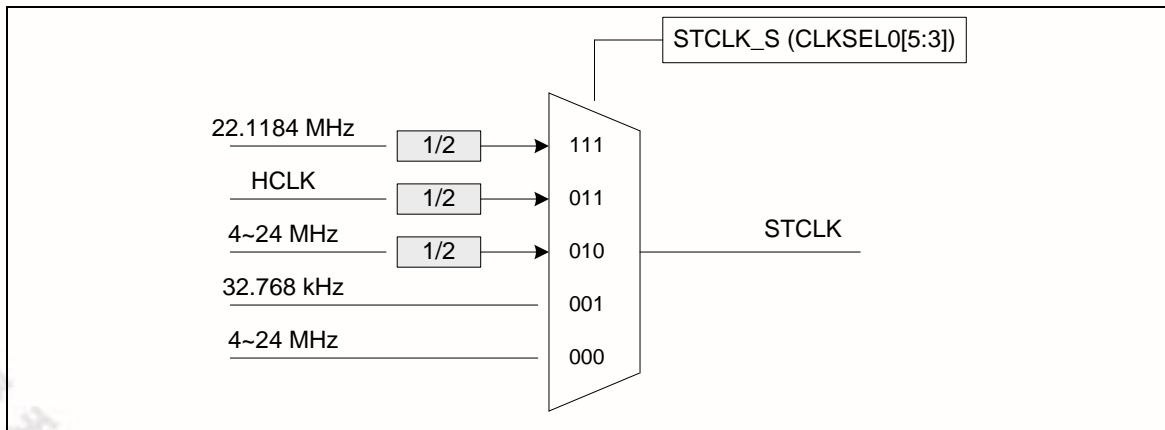

Figure 5-7 SysTick Clock Control Block Diagram

### 5.3.4 Peripherals Clock

The peripherals clock can be selected as different clock source depends on the clock source select control registers (CLKSEL1, CLKSEL2 and CLKSEL3).

### 5.3.5 Power-down Mode Clock

When chip enters Power-down mode, system clocks, some clock sources, and some peripheral clocks will be disabled. Some clock sources and peripherals clocks are still active in Power-down mode.

The clocks still kept active are listed below:

- Clock Generator
  - ◆ Internal 10 kHz low speed oscillator clock
  - ◆ External 32.768 kHz low speed crystal clock
- Peripherals Clock (when IP adopt external 32.768 kHz low speed crystal oscillator or 10 kHz low speed oscillator as clock source)

### 5.3.6 Frequency Divider Output

This device is equipped with a power-of-2 frequency divider which is composed by 16 chained divide-by-2 shift registers. One of the 16 shift register outputs selected by a sixteen to one multiplexer is reflected to CLKO function pin. Therefore there are 16 options of power-of-2 divided clocks with the frequency from  $F_{in}/2^1$  to  $F_{in}/2^{16}$  where  $F_{in}$  is input clock frequency to the clock divider.

The output formula is  $F_{out} = F_{in}/2^{(N+1)}$ , where  $F_{in}$  is the input clock frequency,  $F_{out}$  is the clock divider output frequency and N is the 4-bit value in FSEL (FRQDIV[3:0]).

When writing 1 to DIVIDER\_EN (FRQDIV[4]), the chained counter starts to count. When writing 0 to DIVIDER\_EN (FRQDIV[4]), the chained counter continuously runs till divided clock reaches low state and stay in low state.

If DIVIDER1 (FRQDIV[5]) is set to 1, the frequency divider clock (FRQDIV\_CLK) will bypass power-of-2 frequency divider. The frequency divider clock will be output to CLKO pin directly.

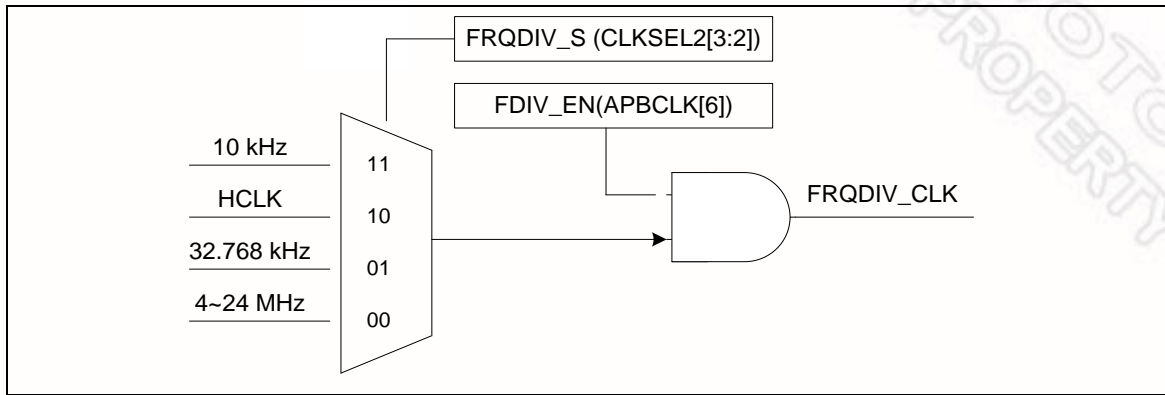

Figure 5-8 Clock Source of Frequency Divider

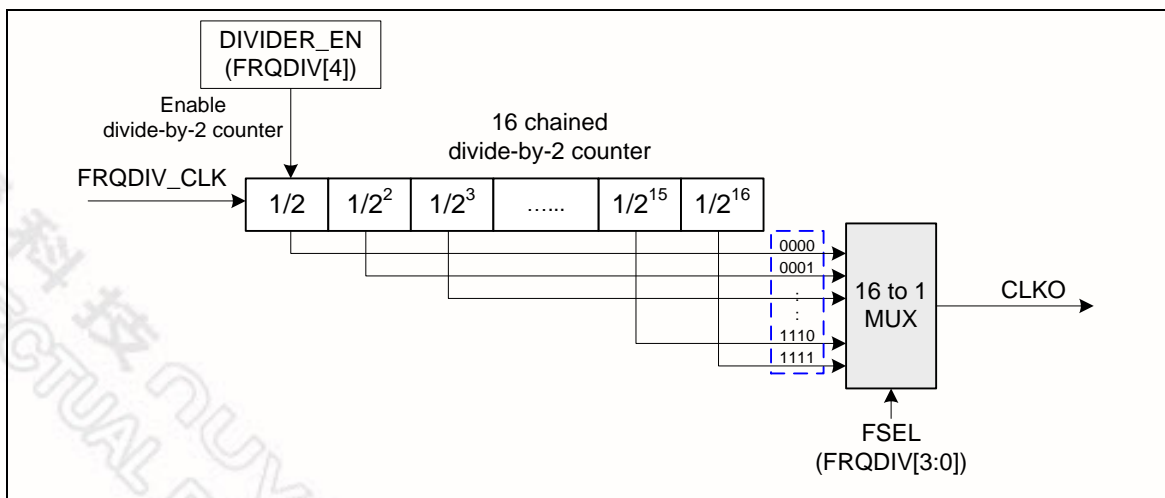

Figure 5-9 Frequency Divider Block Diagram

## 5.4 USB Device Controller (USB)

### 5.4.1 Overview

There is one set of USB 2.0 full-speed device controller and transceiver in this device, which is compliant with USB 2.0 full-speed device specification and supports control/bulk/interrupt/isochronous transfer types.

In this device controller, there are two main interfaces: the APB bus and USB bus which comes from the USB PHY transceiver. For the APB bus, the CPU can program control registers through it. There are 512 bytes internal SRAM as data buffer in this controller. For IN or OUT transfer, it is necessary to write data to SRAM or read data from SRAM through the APB interface or SIE. User needs to set the effective starting address of SRAM for each endpoint buffer through "buffer segmentation register (USB\_BUFSEGx)".

There are 6 endpoints in this controller. Each of the endpoint can be configured as IN or OUT endpoint. All the operations including Control, Bulk, Interrupt and Isochronous transfer are implemented in this block. The block of ENDPOINT CONTROL is also used to manage the data sequential synchronization, endpoint states, current start address, transaction status, and data buffer status for each endpoint.

There are four different interrupt events in this controller. They are the wake-up function, device plug-in or plug-out event, USB events, e.g. IN ACK, OUT ACK, and BUS events, e.g. suspend and resume. Any event will cause an interrupt, and users just need to check the related event flags in interrupt event status register (USB\_INTSTS) to acknowledge what kind of interrupt occurring, and then check the related USB Endpoint Status Register (USB\_EPSTS) to acknowledge what kind of event occurring in this endpoint.

A software-disable function is also supported for this USB controller. It is used to simulate the disconnection of this device from the host. If user enables DRVSE0 bit (USB\_DRVSE0), the USB controller will force the output of USB\_DP and USB\_DM to level low and its function is disabled. After disable the DRVSE0 bit, host will enumerate the USB device again.

Please refer to *Universal Serial Bus Specification Revision 1.1*.

### 5.4.2 Features

This Universal Serial Bus (USB) performs a serial interface with a single connector type for attaching all USB peripherals to the host system. Following is the feature list of this USB.

- Compliant with USB 2.0 Full-Speed specification
- Provides 1 interrupt vector with 4 different interrupt events (WAKE-UP, FLDET, USB and BUS)
- Supports Control/Bulk/Interrupt/Isochronous transfer type
- Supports suspend function when no bus activity existing for 3 ms
- Provides 6 endpoints for configurable Control/Bulk/Interrupt/Isochronous transfer types and maximum 512 bytes buffer size
- Provides remote wake-up capability

## 5.5 General Purpose I/O (GPIO)

### 5.5.1 Overview

The NuMicro™ NUC200 series has up to 80 General Purpose I/O pins to be shared with other function pins depending on the chip configuration. These 80 pins are arranged in 6 ports named as GPIOA, GPIOB, GPIOC, GPIOD, GPIOE and GPIOF. The GPIOA/B/C/D/E port has the maximum of 16 pins and GPIOF port has the maximum of 4 pins. Each of the 80 pins is independent and has the corresponding register bits to control the pin mode function and data.

The I/O type of each of I/O pins can be configured by software individually as input, output, open-drain or Quasi-bidirectional mode. After reset, the I/O mode of all pins are depending on Config0[10] setting. In Quasi-bidirectional mode, I/O pin has a very weak individual pull-up resistor which is about 110~300 K $\Omega$  for  $V_{DD}$  is from 5.0 V to 2.5 V.

### 5.5.2 Features

- Four I/O modes:
  - ◆ Quasi-bidirectional
  - ◆ Push-pull output
  - ◆ Open-Drain output
  - ◆ Input only with high impedance
- TTL/Schmitt trigger input selectable by GPx\_TYPE[15:0] in GPx\_MFP[31:16]
- I/O pin configured as interrupt source with edge/level setting
- Configurable default I/O mode of all pins after reset by Config0[10] setting
  - ◆ If Config[10] is 0, all GPIO pins in input tri-state mode after chip reset
  - ◆ If Config[10] is 1, all GPIO pins in Quasi-bidirectional mode after chip reset
- I/O pin internal pull-up resistor enabled only in Quasi-bidirectional I/O mode
- Enabling the pin interrupt function will also enable the pin wake-up function.

## 5.6 I<sup>2</sup>C Serial Interface Controller (I<sup>2</sup>C)

### 5.6.1 Overview

I<sup>2</sup>C is a two-wire, bidirectional serial bus that provides a simple and efficient method of data exchange between devices. The I<sup>2</sup>C standard is a true multi-master bus including collision detection and arbitration that prevents data corruption if two or more masters attempt to control the bus simultaneously.

Data is transferred between a Master and a Slave. Data bits transfer on the SCL and SDA lines are synchronously on a byte-by-byte basis. Each data byte is 8-bit long. There is one SCL clock pulse for each data bit with the MSB being transmitted first, and an acknowledge bit follows each transferred byte. Each bit is sampled during the high period of SCL; therefore, the SDA line may be changed only during the low period of SCL and must be held stable during the high period of SCL. A transition on the SDA line while SCL is high is interpreted as a command (START or STOP). Please refer to Figure 5-10 for more detailed I<sup>2</sup>C BUS Timing.

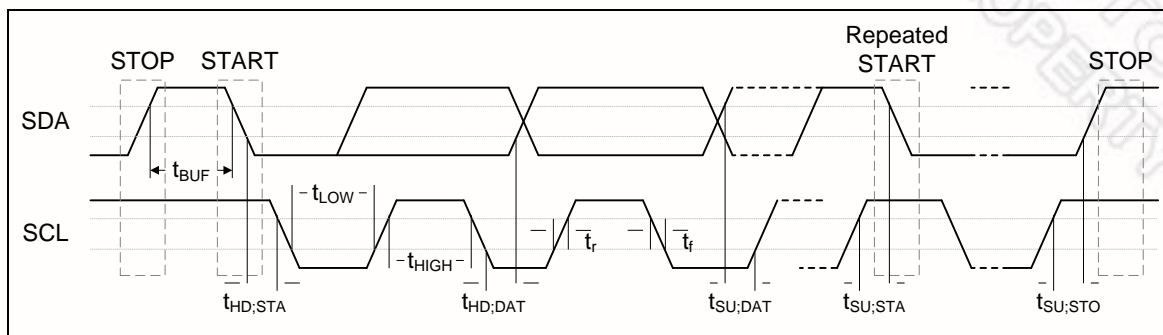

Figure 5-10 I<sup>2</sup>C Bus Timing

The device's on-chip I<sup>2</sup>C logic provides a serial interface that meets the I<sup>2</sup>C bus standard mode specification. The I<sup>2</sup>C port handles byte transfers autonomously. To enable this port, the bit ENS1 in I2CON should be set to '1'. The I<sup>2</sup>C H/W interfaces to the I<sup>2</sup>C bus via two pins: SDA and SCL. Pull-up resistor is needed for I<sup>2</sup>C operation as the SDA and SCL are open drain pins. When I/O pins are used as I<sup>2</sup>C ports, user must set the pins function to I<sup>2</sup>C in advance.

### 5.6.2 Features

The I<sup>2</sup>C bus uses two wires (SDA and SCL) to transfer information between devices connected to the bus. The main features of the bus include:

- Master/Slave mode
- Bidirectional data transfer between masters and slaves
- Multi-master bus (no central master)
- Arbitration between simultaneously transmitting masters without corruption of serial data on the bus
- Serial clock synchronization allowing devices with different bit rates to communicate via one serial bus
- Serial clock synchronization used as a handshake mechanism to suspend and resume serial transfer
- A built-in 14-bit time-out counter requesting the I<sup>2</sup>C interrupt if the I<sup>2</sup>C bus hangs up and timer-out counter overflows.
- External pull-up resistors needed for high output
- Programmable clocks allowing for versatile rate control
- Supports 7-bit addressing mode
- Supports multiple address recognition (four slave addresses with mask option)

## 5.7 PWM Generator and Capture Timer (PWM)

### 5.7.1 Overview

The NuMicro™ NUC200 series has 2 sets of PWM group supporting a total of 4 sets of PWM generators that can be configured as 8 independent PWM outputs, PWM0~PWM7, or as 4 complementary PWM pairs, (PWM0, PWM1), (PWM2, PWM3), (PWM4, PWM5) and (PWM6, PWM7) with 4 programmable Dead-zone generators.

Each PWM generator has one 8-bit prescaler, one clock divider with 5 divided frequencies (1, 1/2, 1/4, 1/8, 1/16), two PWM Timers including two clock selectors, two 16-bit PWM counters for PWM period control, two 16-bit comparators for PWM duty control and one Dead-zone generator. The 4 sets of PWM generators provide eight independent PWM interrupt flags set by hardware when the corresponding PWM period down counter reaches 0. Each PWM interrupt source with its corresponding enable bit can cause CPU to request PWM interrupt. The PWM generators can be configured as one-shot mode to produce only one PWM cycle signal or auto-reload mode to output PWM waveform continuously.

When PCR.DZEN01 is set, PWM0 and PWM1 perform complementary PWM paired function; the paired PWM period, duty and Dead-time are determined by PWM0 timer and Dead-zone generator 0. Similarly, the complementary PWM pairs of (PWM2, PWM3), (PWM4, PWM5) and (PWM6, PWM7) are controlled by PWM2, PWM4 and PWM6 timers and Dead-zone generator 2, 4 and 6, respectively. Refer to [錯誤! 找不到參照來源。](#) and [錯誤! 找不到參照來源。](#) for the architecture of PWM Timers.

To prevent PWM driving output pin with unsteady waveform, the 16-bit period down counter and 16-bit comparator are implemented with double buffer. When user writes data to counter/comparator buffer registers the updated value will be load into the 16-bit down counter/comparator at the time down counter reaching 0. The double buffering feature avoids glitch at PWM outputs.

When the 16-bit period down counter reaches 0, the interrupt request is generated. If PWM-timer is set as auto-reload mode, when the down counter reaches 0, it is reloaded with PWM Counter Register (CNRx) automatically then start decreasing, repeatedly. If the PWM-timer is set as one-shot mode, the down counter will stop and generate one interrupt request when it reaches 0.

The value of PWM counter comparator is used for pulse high width modulation. The counter control logic changes the output to high level when down-counter value matches the value of compare register.

The alternate feature of the PWM-timer is digital input Capture function. If Capture function is enabled the PWM output pin is switched as capture input mode. The Capture0 and PWM0 share one timer which is included in PWM0 and the Capture1 and PWM1 share PWM1 timer, and etc. Therefore user must setup the PWM-timer before enable Capture feature. After capture feature is enabled, the capture always latched PWM-counter to Capture Rising Latch Register (CRLR) when input channel has a rising transition and latched PWM-counter to Capture Falling Latch Register (CFLR) when input channel has a falling transition. Capture channel 0 interrupt is programmable by setting CCR0.CRL\_IE0[1] (Rising latch Interrupt enable) and CCR0.CFL\_IE0[2] (Falling latch Interrupt enable) to decide the condition of interrupt occur. Capture channel 1 has the same feature by setting CCR0.CRL\_IE1[17] and CCR0.CFL\_IE1[18]. And capture channel 2 to channel 3 on each group have the same feature by setting the corresponding control bits in CCR2. For each group, whenever Capture issues Interrupt 0/1/2/3, the PWM counter 0/1/2/3 will be reload at this moment.

The maximum captured frequency that PWM can capture is confined by the capture interrupt latency. When capture interrupt occurred, software will do at least three steps, including: Read PIIR to get interrupt source and Read CRLRx/CFLRx(x=0~3) to get capture value and finally write 1 to clear PIIR to 0. If interrupt latency will take time T0 to finish, the capture signal mustn't transition during this interval (T0). In this case, the maximum capture frequency will be 1/T0. For



example:

HCLK = 50 MHz, PWM\_CLK = 25 MHz, Interrupt latency is 900 ns

So the maximum capture frequency will be  $1/900\text{ns} \approx 1000\text{ kHz}$

## 5.7.2 Features

### 5.7.2.1 PWM function:

- Up to 2 PWM groups (PWMA/PWMB) to support 8 PWM channels or 4 complementary PWM paired channels
- Each PWM group has two PWM generators with each PWM generator supporting one 8-bit prescaler, two clock divider, two PWM-timers, one Dead-zone generator and two PWM outputs.
- Up to 16-bit resolution
- PWM Interrupt request synchronized with PWM period
- One-shot or Auto-reload mode PWM
- Edge-aligned type or Center-aligned type option

### 5.7.2.2 Capture Function:

- Timing control logic shared with PWM generators
- Supports 8 Capture input channels shared with 8 PWM output channels
- Each channel supports one rising latch register (CRLR), one falling latch register (CFLR) and Capture interrupt flag (CAPIFx)

## 5.8 Real Time Clock (RTC)

### 5.8.1 Overview

The Real Time Clock (RTC) controller provides user with the real time and calendar message. The clock source of RTC controller is from an external 32.768 kHz low speed crystal which connected at pins X32\_IN and X32\_OUT (refer to pin Description) or from an external 32.768 kHz low speed oscillator output fed at pin X32\_IN. The RTC controller provides the real time message (hour, minute, second) in TLR (RTC Time Loading Register) as well as calendar message (year, month, day) in CLR (RTC Calendar Loading Register). It also offers RTC alarm function that user can preset the alarm time in TAR (RTC Time Alarm Register) and alarm calendar in CAR (RTC Calendar Alarm Register). The data format of RTC time and calendar message are all expressed in BCD format.

The RTC controller supports periodic RTC Time Tick and Alarm Match interrupts. The periodic RTC Time Tick interrupt has 8 period interval options 1/128, 1/64, 1/32, 1/16, 1/8, 1/4, 1/2 and 1 second which are selected by TTR (TTR[2:0] Time Tick Register). When real time and calendar message in TLR and CLR are equal to alarm time and calendar settings in TAR and CAR, the AIF (RIIR [0] RTC Alarm Interrupt Flag) is set to 1 and the RTC alarm interrupt signal is generated if the AIER (RIER [0] Alarm Interrupt Enable) is enabled.

Both RTC Time Tick and Alarm Match interrupt signal can cause chip to wake-up from Idle or Power-down mode if the correlate interrupt enable bit (AIER or TIER) is set to 1 before chip enters Idle or Power-down mode.

### 5.8.2 Features

- Supports real time counter in TLR (hour, minute, second) and calendar counter in CLR (year, month, day) for RTC time and calendar check
- Supports alarm time (hour, minute, second) and calendar (year, month, day) settings in TAR and CAR
- Selectable 12-hour or 24-hour time scale in TSSR register
- Supports Leap Year indication in LIR register
- Supports Day of the Week counter in DWR register
- Frequency of RTC clock source compensate by FCR register
- All time and calendar message expressed in BCD format
- Supports periodic RTC Time Tick interrupt with 8 period interval options 1/128, 1/64, 1/32, 1/16, 1/8, 1/4, 1/2 and 1 second
- Supports RTC Time Tick and Alarm Match interrupt
- Supports chip wake-up from Idle or Power-down mode while a RTC interrupt signal is generated

## 5.9 Serial Peripheral Interface (SPI)

### 5.9.1 Overview

The Serial Peripheral Interface (SPI) is a synchronous serial data communication protocol that operates in full duplex mode. Devices communicate in Master/Slave mode with the 4-wire bi-direction interface. The NuMicro™ NUC200 series contains up to four sets of SPI controllers performing a serial-to-parallel conversion on data received from a peripheral device, and a parallel-to-serial conversion on data transmitted to a peripheral device. Each set of SPI controller can be configured as a master or a slave device.

The SPI controller supports the variable serial clock function for special applications and 2-bit Transfer mode to connect 2 off-chip slave devices at the same time. This controller also supports the PDMA function to access the data buffer and also supports Dual I/O Transfer mode.

### 5.9.2 Features

- Up to four sets of SPI controllers
- Supports Master or Slave mode operation
- Supports 2-bit Transfer mode
- Supports Dual I/O Transfer mode
- Configurable bit length of a transfer word from 8 to 32-bit
- Provides separate 8-layer depth transmit and receive FIFO buffers
- Supports MSB first or LSB first transfer sequence
- Two slave select lines in Master mode
- Supports the byte reorder function
- Supports Byte or Word Suspend mode
- Variable output serial clock frequency in Master mode
- Supports PDMA transfer
- Supports 3-wire, no slave select signal, bi-direction interface

## 5.10 Timer Controller (TMR)

### 5.10.1 Overview

The timer controller includes four 32-bit timers, TIMER0~TIMER3, allowing user to easily implement a timer control for applications. The timer can perform functions, such as frequency measurement, event counting, interval measurement, clock generation, and delay timing. The timer can generate an interrupt signal upon time-out, or provide the current value during operation.

### 5.10.2 Features

- Four sets of 32-bit timers with 24-bit up counter and one 8-bit prescale counter
- Independent clock source for each timer
- Provides one-shot, periodic, toggle and continuous counting operation modes
- Time-out period = (Period of timer clock input) \* (8-bit prescale counter + 1) \* (24-bit TCMP)
- Maximum counting cycle time =  $(1 / T \text{ MHz}) * (2^8) * (2^{24})$ , T is the period of timer clock
- 24-bit up counter value is readable through TDR (Timer Data Register)
- Supports event counting function to count the event from external pin
- Supports external pin capture function for interval measurement
- Supports external pin capture function for reset timer counter
- Supports chip wake-up from Idle/Power-down mode if a timer interrupt signal is generated (TIF set to 1)

## 5.11 Watchdog Timer (WDT)

### 5.11.1 Overview

The purpose of Watchdog Timer is to perform a system reset when system runs into an unknown state. This prevents system from hanging for an infinite period of time. Besides, this Watchdog Timer supports the function to wake-up system from Idle/Power-down mode.

### 5.11.2 Features

- 18-bit free running up counter for Watchdog Timer time-out interval.
- Selectable time-out interval ( $2^4 \sim 2^{18}$ ) and the time-out interval is 104 ms ~ 26.3168 s if WDT\_CLK = 10 kHz.
- System kept in reset state for a period of  $(1 / \text{WDT\_CLK}) * 63$
- Supports selectable Watchdog Timer reset delay period, it includes (1024+2) 、 (128+2) 、 (16+2) or (1+2) WDT\_CLK reset delay period.
- Supports force Watchdog Timer enabled after chip powered on or reset while CWDTEN (Config0[31] watchdog enable) bit is set to 0.
- Supports Watchdog Timer time-out wake-up function when WDT clock source is selected to 10 kHz low speed oscillator.

## 5.12 Window Watchdog Timer (WWDT)

### 5.12.1 Overview

The purpose of Window Watchdog Timer is to perform a system reset within a specified window period to prevent software run to uncontrollable status by any unpredictable condition.

### 5.12.2 Features

- 6-bit down counter (WWDTVAL[5:0]) and 6-bit compare value (WWDTCCR[21:16] – WINCMP value) to make the window period flexible
- Selectable maximum 11-bit WWDT clock prescale (WWDTCCR[11:8] – PERIODSEL value) to make WWDT time-out interval variable

### 5.13 UART Interface Controller (UART)

The NuMicro™ NUC200 series provides up to three channels of Universal Asynchronous Receiver/Transmitters (UART). UART0 supports High Speed UART and UART1~2 perform Normal Speed UART. Besides, only UART0 and UART1 support the flow control function.

#### 5.13.1 Overview

The Universal Asynchronous Receiver/Transmitter (UART) performs a serial-to-parallel conversion on data received from the peripheral, and a parallel-to-serial conversion on data transmitted from the CPU. The UART controller also supports IrDA SIR, LIN master/slave mode and RS-485 mode functions. Each UART channel supports seven types of interrupts including:

- Transmitter FIFO empty interrupt (INT\_THRE);
- Receiver threshold level reached interrupt (INT\_RDA);
- Line status interrupt (parity error or frame error or break interrupt) (INT\_RLS);
- Receiver buffer time-out interrupt (INT\_TOUT);
- MODEM/Wake-up status interrupt (INT\_MODEM);
- Buffer error interrupt (INT\_BUF\_ERR);
- LIN interrupt (INT\_LIN).

Interrupts of UART0 and UART2 share the interrupt number 12 (vector number is 28); Interrupt number 13 (vector number is 29) only supports UART1 interrupt. Refer to the Nested Vectored Interrupt Controller chapter for System Interrupt Map.

The UART0 is built-in with a 64-byte transmitter FIFO (TX\_FIFO) and a 64-byte receiver FIFO (RX\_FIFO) that reduces the number of interrupts presented to the CPU. The UART1~2 are equipped with 16-byte transmitter FIFO (TX\_FIFO) and 16-byte receiver FIFO (RX\_FIFO). The CPU can read the status of the UART at any time during the operation. The reported status information includes the type and condition of the transfer operations being performed by the UART, as well as 4 error conditions (parity error, frame error, break interrupt and buffer error) probably occur while receiving data. The UART includes a programmable baud rate generator that is capable of dividing clock input by divisors to produce the serial clock that transmitter and receiver need. The baud rate equation is  $\text{Baud Rate} = \text{UART\_CLK} / M * [\text{BRD} + 2]$ , where M and BRD are defined in Baud Rate Divider Register (UA\_BAUD). Table 5-5 lists the equations in the various conditions and Table 5-6 lists the UART baud rate setting table.

Mode	DIV_X_EN	DIV_X_ONE	Divider X	BRD	Baud Rate Equation
0	0	0	Don't care	A	$\text{UART\_CLK} / [16 * (A+2)]$
1	1	0	B	A	$\text{UART\_CLK} / [(B+1) * (A+2)]$ , B must $\geq 8$
2	1	1	Don't care	A	$\text{UART\_CLK} / (A+2)$ , A must $\geq 3$

Table 5-5 UART Baud Rate Equation

System clock = internal 22.1184 MHz high speed oscillator			
Baud Rate	Mode 0	Mode 1	Mode 2

	Parameter	Register	Parameter	Register	Parameter	Register
921600	x	x	A=0,B=11	0x2B00_0000	A=22	0x3000_0016
460800	A=1	0x0000_0001	A=1,B=15 A=2,B=11	0x2F00_0001 0x2B00_0002	A=46	0x3000_002E
230400	A=4	0x0000_0004	A=4,B=15 A=6,B=11	0x2F00_0004 0x2B00_0006	A=94	0x3000_005E
115200	A=10	0x0000_000A	A=10,B=15 A=14,B=11	0x2F00_000A 0x2B00_000E	A=190	0x3000_00BE
57600	A=22	0x0000_0016	A=22,B=15 A=30,B=11	0x2F00_0016 0x2B00_001E	A=382	0x3000_017E
38400	A=34	0x0000_0022	A=62,B=8 A=46,B=11 A=34,B=15	0x2800_003E 0x2B00_002E 0x2F00_0022	A=574	0x3000_023E
19200	A=70	0x0000_0046	A=126,B=8 A=94,B=11 A=70,B=15	0x2800_007E 0x2B00_005E 0x2F00_0046	A=1150	0x3000_047E
9600	A=142	0x0000_008E	A=254,B=8 A=190,B=11 A=142,B=15	0x2800_00FE 0x2B00_00BE 0x2F00_008E	A=2302	0x3000_08FE
4800	A=286	0x0000_011E	A=510,B=8 A=382,B=11 A=286,B=15	0x2800_01FE 0x2B00_017E 0x2F00_011E	A=4606	0x3000_11FE

Table 5-6 UART Baud Rate Setting Table

The UART0 and UART1 controllers support the auto-flow control function that uses two low-level signals, nCTS (clear-to-send) and nRTS (request-to-send), to control the flow of data transfer between the chip and external devices (e.g. Modem). When auto-flow is enabled, the UART is not allowed to receive data until the UART asserts nRTS to external device. When the number of bytes in the RX FIFO equals the value of RTS\_TRI\_LEV (UA\_FCR [19:16]), the nRTS is de-asserted. The UART sends data out when UART controller detects nCTS is asserted from external device. If a valid asserted nCTS is not detected the UART controller will not send data out.

The UART controllers also provides Serial IrDA (SIR, Serial Infrared) function (User must set IrDA\_EN (UA\_FUN\_SEL [1]) to enable IrDA function). The SIR specification defines a short-range infrared asynchronous serial transmission mode with 1 start bit, 8 data bits, and 1 stop bit. The maximum data rate supports up to 115.2 Kbps (half duplex). The IrDA SIR block contains an IrDA SIR Protocol encoder/decoder. The IrDA SIR Protocol encoder/decoder is half-duplex only. So it cannot transmit and receive data at the same time. The IrDA SIR physical layer specifies a minimum 10ms transfer delay between transmission and reception, and this delay feature must be implemented by software.

The alternate function of UART controllers is LIN (Local Interconnect Network) function. The LIN mode is selected by setting the UA\_FUN\_SEL[1:0] to '01'. In LIN mode, 1 start bit and 8 data bits format with 1 stop bit are required in accordance with the LIN standard.

For NuMicro™ NUC200 Series, another alternate function of UART controllers is RS-485 9-bit mode, and direction control provided by nRTS pin or can program GPIO (PB.2 for UART0\_nRTS and PB.6 for UART1\_nRTS) to implement the function by software. The RS-485 mode is selected

by setting the UA\_FUN\_SEL register to select RS-485 function. The RS-485 transceiver control is implemented using the nRTS control signal from an asynchronous serial port to enable the RS-485 transceiver. In RS-485 mode, many characteristics of the receiving and transmitting are same as UART.

### 5.13.2 Features

- Full duplex, asynchronous communications
- Separates receive / transmit 64/16/16 bytes (UART0/UART1/UART2) entry FIFO for data payloads
- Supports hardware auto flow control/flow control function (nCTS, nRTS) and programmable nRTS flow control trigger level (UART0 and UART1 support)
- Programmable receiver buffer trigger level
- Supports programmable baud-rate generator for each channel individually
- Supports nCTS wake-up function (UART0 and UART1 support)
- Supports 7-bit receiver buffer time-out detection function
- UART0/UART1 can through DMA channels to receive/transmit data
- Programmable transmitting data delay time between the last stop and the next start bit by setting UA\_TOR [DLY] register
- Supports break error, frame error, parity error and receive / transmit buffer overflow detect function
- Fully programmable serial-interface characteristics
  - Programmable data bit length, 5-, 6-, 7-, 8-bit character
  - Programmable parity bit, even, odd, no parity or stick parity bit generation and detection
  - Programmable stop bit length, 1, 1.5, or 2 stop bit generation
- IrDA SIR function mode
  - Supports 3-/16-bit duration for normal mode
- LIN function mode
  - Supports LIN master/slave mode
  - Supports programmable break generation function for transmitter
  - Supports break detect function for receiver
- RS-485 function mode.
  - Supports RS-485 9-bit mode
  - Supports hardware or software direct enable control provided by nRTS pin



## 5.14 PS/2 Device Controller (PS2D)

### 5.14.1 Overview

PS/2 device controller provides a basic timing control for PS/2 communication. All communication between the device and the host is managed through the PS2\_CLK and PS2\_DAT pins. Unlike PS/2 keyboard or mouse device controller, the receive/transmit code needs to be translated as meaningful code by firmware. The device controller generates the PS2\_CLK signal after receiving a “Request to Send” state, but host has ultimate control over communication. Data of PS2\_DAT line sent from the host to the device is read on the rising edge and sent from the device to the host is change after rising edge. A 16 bytes FIFO is used to reduce CPU intervention. Software can select 1 to 16 bytes for a continuous transmission.

### 5.14.2 Features

- Host communication inhibit and Request to Send state detection
- Reception frame error detection
- Programmable 1 to 16 bytes transmit buffer to reduce CPU intervention
- Double buffer for data reception
- Software override bus

## 5.15 I<sup>2</sup>S Controller (I<sup>2</sup>S)

### 5.15.1 Overview

The I<sup>2</sup>S controller consists of I<sup>2</sup>S protocol to interface with external audio CODEC. Two 8-word deep FIFO for read path and write path respectively and is capable of handling 8-, 16-, 24- and 32-bit word sizes. PDMA controller handles the data movement between FIFO and memory.

### 5.15.2 Features

- Operated as either Master or Slave
- Capable of handling 8-, 16-, 24- and 32-bit word sizes
- Supports Mono and stereo audio data
- Supports I<sup>2</sup>S and MSB justified data format
- Provides two 8-word FIFO data buffers, one for transmitting and the other for receiving
- Generates interrupt requests when buffer levels cross a programmable boundary
- Two PDMA requests, one for transmitting and the other for receiving

## 5.16 Analog-to-Digital Converter (ADC)

### 5.16.1 Overview

The NuMicro™ NUC200 Series contains one 12-bit successive approximation analog-to-digital converters (SAR A/D converter) with 8 input channels. The A/D converter supports three operation modes: single, single-cycle scan and continuous scan mode. The A/D converter can be started by software, PWM Center-aligned trigger and external STADC pin.

### 5.16.2 Features

- Analog input voltage range:  $0 \sim V_{REF}$
- 12-bit resolution and 10-bit accuracy is guaranteed
- Up to 8 single-end analog input channels or 4 differential analog input channels
- Up to 760 kSPS conversion rate as ADC clock frequency is 16 MHz (chip working at 5V)
- Three operating modes
  - Single mode: A/D conversion is performed one time on a specified channel
  - Single-cycle scan mode: A/D conversion is performed one cycle on all specified channels with the sequence from the smallest numbered channel to the largest numbered channel
  - Continuous scan mode: A/D converter continuously performs Single-cycle scan mode until software stops A/D conversion
- An A/D conversion can be started by:
  - Writing 1 to ADST bit through software
  - PWM Center-aligned trigger
  - External pin STADC
- Conversion results are held in data registers for each channel with valid and overrun indicators
- Conversion result can be compared with specify value and user can select whether to generate an interrupt when conversion result matches the compare register setting
- Channel 7 supports 3 input sources: external analog voltage, internal Band-gap voltage, and internal temperature sensor output

## 5.17 Analog Comparator (ACMP)

### 5.17.1 Overview

The NuMicro™ NUC200 Series contains two comparators which can be used in a number of different configurations. The comparator output is logic 1 when positive input voltage is greater than negative input voltage; otherwise the output is logic 0. Each comparator can be configured to cause an interrupt when the comparator output value changes. The block diagram is shown in 錯誤! 找不到參照來源。 .

### 5.17.2 Features

- Analog input voltage range: 0~  $V_{DDA}$
- Supports Hysteresis function
- Supports optional internal reference voltage input at negative end for each comparator

## 5.18 PDMA Controller (PDMA)

### 5.18.1 Overview

The NuMicro™ NUC200 series DMA contains nine-channel peripheral direct memory access (PDMA) controller and a cyclic redundancy check (CRC) generator.

The PDMA that transfers data to and from memory or transfer data to and from APB devices. For PDMA channel (PDMA CH0~CH8), there is one-word buffer as transfer buffer between the Peripherals APB devices and Memory. Software can stop the PDMA operation by disable PDMA PDMA\_CSRx[PDMACEN]. The CPU can recognize the completion of a PDMA operation by software polling or when it receives an internal PDMA interrupt. The PDMA controller can increase source or destination address or fixed them as well.

The DMA controller contains a cyclic redundancy check (CRC) generator that can perform CRC calculation with programmable polynomial settings. The CRC engine supports CPU PIO mode and DMA transfer mode.

### 5.18.2 Features

- Supports nine PDMA channels and one CRC channel. Each PDMA channel can support a unidirectional transfer
- AMBA AHB master/slave interface compatible, for data transfer and register read/write
- Hardware round robin priority scheme. DMA channel 0 has the highest priority and channel 8 has the lowest priority
- PDMA operation
  - Peripheral-to-memory, memory-to-peripheral, and memory-to-memory transfer
  - Supports word/half-word/byte transfer data width from/to peripheral
  - Supports address direction: increment, fixed.
- Cyclic Redundancy Check (CRC)
  - Supports four common polynomials CRC-CCITT, CRC-8, CRC-16, and CRC-32
    - CRC-CCITT:  $X^{16} + X^{12} + X^5 + 1$
    - CRC-8:  $X^8 + X^2 + X + 1$
    - CRC-16:  $X^{16} + X^{15} + X^2 + 1$
    - CRC-32:  $X^{32} + X^{26} + X^{23} + X^{22} + X^{16} + X^{12} + X^{11} + X^{10} + X^8 + X^7 + X^5 + X^4 + X^2 + X + 1$
  - Supports programmable CRC seed value.
  - Supports programmable order reverse setting for input data and CRC checksum.
  - Supports programmable 1's complement setting for input data and CRC checksum.
  - Supports CPU PIO mode or DMA transfer mode.
  - Supports the follows write data length in CPU PIO mode
    - 8-bit write mode (byte): 1-AHB clock cycle operation.
    - 16-bit write mode (half-word): 2-AHB clock cycle operation.
    - 32-bit write mode (word): 4-AHB clock cycle operation.
  - Supports byte alignment transfer data length and word alignment transfer source address in CRC DMA mode.

## 5.19 Smart Card Host Interface (SC)

### 5.19.1 Overview

The Smart Card Interface controller (SC controller) is based on ISO/IEC 7816-3 standard and fully compliant with PC/SC Specifications. It also provides status of card insertion/removal.

### 5.19.2 Features

- ISO7816-3 T=0, T=1 compliant
- EMV2000 compliant
- Supports up to three ISO7816-3 ports
- Separates receive/ transmit 4 byte entry buffer for data payloads
- Programmable transmission clock frequency
- Programmable receiver buffer trigger level
- Programmable guard time selection (11 ETU ~ 266 ETU)
- One 24-bit and two 8-bit time-out counters for Answer to Request (ATR) and waiting times processing
- Supports auto inverse convention function
- Supports transmitter and receiver error retry and error retry number limitation function
- Supports hardware activation sequence process
- Supports hardware warm reset sequence process
- Supports hardware deactivation sequence process
- Supports hardware auto deactivation sequence when detecting the card removal

## 5.20 FLASH MEMORY CONTROLLER (FMC)

### 5.20.1 Overview

The NuMicro™ NUC200 Series has 128/64/32K bytes on-chip embedded Flash for application program memory (APROM) that can be updated through ISP procedure. The In-System-Programming (ISP) function enables user to update program memory when chip is soldered on PCB. After chip is powered on, Cortex™-M0 CPU fetches code from APROM or LDROM decided by boot select (CBS) in Config0. By the way, the NuMicro™ NUC200 Series also provides additional DATA Flash for user to store some application dependent data. For 128K bytes APROM device, the data flash is shared with original 128K program memory and its start address is configurable in Config1. For 64K/32K bytes APROM device, the data flash is fixed at 4K.

### 5.20.2 Features

- Runs up to 50 MHz with zero wait state for continuous address read access
- All embedded flash memory supports 512 bytes page erase
- 128/64/32 KB application program memory (APROM)
- 4 KB In-System-Programming (ISP) loader program memory (LDROM)
- 4KB data flash for 64/32 KB APROM device
- Configurable data flash size for 128KB APROM device
- Configurable or fixed 4 KB data flash with 512 bytes page erase unit
- Supports In-Application-Programming (IAP) to switch code between APROM and LDROM without reset
- In-System-Programming (ISP) to update on-chip Flash

## 6 ELECTRICAL CHARACTERISTICS

### 6.1 Absolute Maximum Ratings

SYMBOL	PARAMETER	MIN.	MAX	UNIT
DC Power Supply	$V_{DD}-V_{SS}$	-0.3	+7.0	V
Input Voltage	$V_{IN}$	$V_{SS}-0.3$	$V_{DD}+0.3$	V
Oscillator Frequency	$1/t_{CLCL}$	4	24	MHz
Operating Temperature	TA	-40	+85	°C
Storage Temperature	TST	-55	+150	°C
Maximum Current into $V_{DD}$		-	120	mA
Maximum Current out of $V_{SS}$			120	mA
Maximum Current sunk by a I/O pin			35	mA
Maximum Current sourced by a I/O pin			35	mA
Maximum Current sunk by total I/O pins			100	mA
Maximum Current sourced by total I/O pins			100	mA

**Note:** Exposure to conditions beyond those listed under absolute maximum ratings may adversely affects the lift and reliability of the device.



## 6.2 DC Electrical Characteristics

( $V_{DD}-V_{SS}=5.5\text{ V}$ ,  $T_A = 25^\circ\text{C}$ ,  $F_{OSC} = 50\text{ MHz}$  unless otherwise specified.)

PARAMETER	SYM.	SPECIFICATION				TEST CONDITIONS
		MIN.	TYP.	MAX.	UNIT	
Operation Voltage	$V_{DD}$	2.5		5.5	V	$V_{DD} = 2.5\text{V} \sim 5.5\text{V}$ up to 50 MHz
Power Ground	$V_{SS}$ $AV_{SS}$	-0.3			V	
LDO Output Voltage	$V_{LDO}$	1.62	1.8	1.98	V	$V_{DD} > 2.5\text{V}$
Analog Operating Voltage	$AV_{DD}$		$V_{DD}$		V	When system used analog function, please refer to chapter 6.4 for corresponding analog operating voltage
Operating Current Normal Run Mode at 50 MHz	$I_{DD1}$		34		mA	$V_{DD} = 5.5\text{V}$ , All IP and PLL enabled, XTAL = 12 MHz
	$I_{DD2}$		15		mA	$V_{DD} = 5.5\text{V}$ , All IP disabled and PLL enabled, XTAL = 12 MHz
	$I_{DD3}$		32		mA	$V_{DD} = 3.3\text{V}$ , All IP and PLL enabled, XTAL = 12 MHz
	$I_{DD4}$		14		mA	$V_{DD} = 3.3\text{V}$ , All IP disabled and PLL enabled, XTAL = 12 MHz
Operating Current Normal Run Mode at 12 MHz	$I_{DD5}$		8.5		mA	$V_{DD} = 5.5\text{V}$ , All IP enabled and PLL disabled, XTAL = 12 MHz
	$I_{DD6}$		3.6		mA	$V_{DD} = 5.5\text{V}$ , All IP and PLL disabled, XTAL = 12 MHz
	$I_{DD7}$		7.5		mA	$V_{DD} = 3.3\text{V}$ , All IP enabled and PLL disabled, XTAL = 12 MHz

PARAMETER	SYM.	SPECIFICATION				TEST CONDITIONS
		MIN.	TYP.	MAX.	UNIT	
	I <sub>DD8</sub>		2.6		mA	V <sub>DD</sub> = 3.3V, All IP and PLL disabled, XTAL = 12 MHz
Operating Current Normal Run Mode at 4 MHz	I <sub>DD9</sub>		3.6		mA	V <sub>DD</sub> = 5.5V, All IP enabled and PLL disabled, XTAL = 4 MHz
	I <sub>DD10</sub>		2		mA	V <sub>DD</sub> = 5.5V, All IP and PLL disabled, XTAL = 4 MHz
	I <sub>DD11</sub>		2.8		mA	V <sub>DD</sub> = 3.3V, All IP enabled and PLL disabled, XTAL = 4 MHz
	I <sub>DD12</sub>		1.2		mA	V <sub>DD</sub> = 3.3V, All IP and PLL disabled, XTAL = 4 MHz
Operating Current Normal Run Mode at 32.768 kHz	I <sub>DD13</sub>		141		μA	V <sub>DD</sub> = 5.5V, All IP enabled and PLL disabled, XTAL = 32.768 kHz
	I <sub>DD14</sub>		129		μA	V <sub>DD</sub> = 5.5V, All IP and PLL disabled, XTAL = 32.768 kHz
	I <sub>DD15</sub>		138		μA	V <sub>DD</sub> = 3.3V, All IP enabled and PLL disabled, XTAL = 32.768 kHz
	I <sub>DD16</sub>		125		μA	V <sub>DD</sub> = 3.3V, All IP and PLL disabled, XTAL = 32.768 kHz
Operating Current Normal Run Mode at 10 kHz	I <sub>DD17</sub>		125		μA	V <sub>DD</sub> = 5.5V, All IP enabled and PLL disabled, LIRC10 kHz enabled
	I <sub>DD18</sub>		120		μA	V <sub>DD</sub> = 5.5V, All IP and PLL disabled, LIRC10 kHz enabled

PARAMETER	SYM.	SPECIFICATION				TEST CONDITIONS
		MIN.	TYP.	MAX.	UNIT	
	I <sub>DD19</sub>		125		μA	V <sub>DD</sub> = 3.3V, All IP enabled and PLL disabled, LIRC10 kHz enabled
	I <sub>DD20</sub>		120		μA	V <sub>DD</sub> = 3.3V, All IP and PLL disabled, LIRC10kHz enabled
Operating Current Idle Mode at 50 MHz	I <sub>IDLE1</sub>		28		mA	V <sub>DD</sub> = 5.5V, All IP and PLL enabled, XTAL = 12 MHz
	I <sub>IDLE2</sub>		10		mA	V <sub>DD</sub> = 5.5V, All IP disabled and PLL enabled, XTAL = 12 MHz
	I <sub>IDLE3</sub>		27		mA	V <sub>DD</sub> = 3.3V, All IP and PLL enabled, XTAL = 12 MHz
	I <sub>IDLE4</sub>		9		mA	V <sub>DD</sub> = 3.3V All IP disabled and PLL enabled, XTAL = 12 MHz
Operating Current Idle Mode at 12 MHz	I <sub>IDLE5</sub>		7.5		mA	V <sub>DD</sub> = 5.5V, All IP enabled and PLL disabled, XTAL = 12 MHz
	I <sub>IDLE6</sub>		2.4		mA	V <sub>DD</sub> = 5.5V, All IP and PLL disabled, XTAL = 12 MHz
	I <sub>IDLE7</sub>		6.5		mA	V <sub>DD</sub> = 3.3V, All IP enabled and PLL enabled, XTAL = 12 MHz
	I <sub>IDLE8</sub>		1.5		mA	V <sub>DD</sub> = 3.3V, All IP and PLL disabled, XTAL = 12 MHz
Operating Current Idle Mode at 4 MHz	I <sub>IDLE9</sub>		3.3		mA	V <sub>DD</sub> = 5.5V, All IP enabled and PLL disabled, XTAL = 4 MHz



PARAMETER	SYM.	SPECIFICATION				TEST CONDITIONS
		MIN.	TYP.	MAX.	UNIT	
	I <sub>IDLE10</sub>		1.7		mA	V <sub>DD</sub> = 5.5V All IP and PLL disabled, XTAL = 4 MHz
	I <sub>IDLE11</sub>		2.4		mA	V <sub>DD</sub> = 3.3V, All IP enabled and PLL disabled, XTAL = 4 MHz
	I <sub>IDLE12</sub>		0.8		mA	V <sub>DD</sub> = 3.3V, All IP and PLL disabled, XTAL = 4 MHz
Operating Current Idle Mode at 32.768 kHz	I <sub>IDLE13</sub>		133		μA	V <sub>DD</sub> = 5.5V, All IP enabled and PLL disabled, XTAL = 32.768 kHz
	I <sub>IDLE14</sub>		120		μA	V <sub>DD</sub> = 5.5V, All IP and PLL disabled, XTAL = 32.768 kHz
	I <sub>IDLE15</sub>		133		μA	V <sub>DD</sub> = 3.3V, All IP enabled and PLL disabled, XTAL = 32.768 kHz
	I <sub>IDLE16</sub>		120		μA	V <sub>DD</sub> = 3.3V, All IP and PLL disabled, XTAL = 32.768 kHz
Operating Current Idle Mode at 10 kHz	I <sub>IDLE13</sub>		122		μA	V <sub>DD</sub> = 5.5V, All IP enabled and PLL disabled, LIRC10 kHz enabled
	I <sub>IDLE14</sub>		118		μA	V <sub>DD</sub> = 5.5V, All IP and PLL disabled, LIRC10 kHz enabled
	I <sub>IDLE15</sub>		122		μA	V <sub>DD</sub> = 3.3V, All IP enabled and PLL disabled, LIRC10 kHz enabled
	I <sub>IDLE16</sub>		118		μA	V <sub>DD</sub> = 3.3V All IP and PLL disabled, LIRC10 kHz enabled
Standby Current	I <sub>PWD1</sub>		15		μA	V <sub>DD</sub> = 5.5V, RTC disabled, When BOD function disabled



PARAMETER	SYM.	SPECIFICATION				TEST CONDITIONS
		MIN.	TYP.	MAX.	UNIT	
Power-down Mode (Deep Sleep Mode)	I <sub>PWD2</sub>		15		μA	V <sub>DD</sub> = 3.3V, RTC disabled, When BOD function disabled
	I <sub>PWD3</sub>		17		μA	V <sub>DD</sub> = 5.5V, RTC enabled , When BOD function disabled
	I <sub>PWD4</sub>		17		μA	V <sub>DD</sub> = 3.3V, RTC enabled , When BOD function disabled
Input Current PA, PB, PC, PD, PE, PF (Quasi- bidirectional mode)	I <sub>IN1</sub>		-50	-60	μA	V <sub>DD</sub> = 5.5V, V <sub>IN</sub> = 0V or V <sub>IN</sub> =V <sub>DD</sub>
Input Current at nRESET <sup>[1]</sup>	I <sub>IN2</sub>	-55	-45	-30	μA	V <sub>DD</sub> = 3.3V, V <sub>IN</sub> = 0.45V
Input Leakage Current PA, PB, PC, PD, PE, PF	I <sub>LK</sub>	-2	-	+2	μA	V <sub>DD</sub> = 5.5V, 0<V <sub>IN</sub> <V <sub>DD</sub>
Logic 1 to 0 Transition Current PA~PF (Quasi-bidirectional mode)	I <sub>TL</sub> <sup>[3]</sup>	-650	-	-200	μA	V <sub>DD</sub> = 5.5V, V <sub>IN</sub> <2.0V
Input Low Voltage PA, PB, PC, PD, PE, PF (TTL input)	V <sub>IL1</sub>	-0.3	-	0.8	V	V <sub>DD</sub> = 4.5V
		-0.3	-	0.6		V <sub>DD</sub> = 2.5V
Input High Voltage PA, PB, PC, PD, PE, PF (TTL input)	V <sub>IH1</sub>	2.0	-	V <sub>DD</sub> +0.2	V	V <sub>DD</sub> = 5.5V
		1.5	-	V <sub>DD</sub> +0.2		V <sub>DD</sub> = 3.0V
Input Low Voltage PA, PB, PC, PD, PE, PF (Schmitt input)	V <sub>IL2</sub>	-0.3	-	0.3V <sub>DD</sub>	V	
Input High Voltage PA, PB, PC, PD, PE, PF (Schmitt input)	V <sub>IH2</sub>	0.7V <sub>DD</sub>	-	V <sub>DD</sub> +0.2	V	
Hysteresis voltage of PA, PB, PC, PD, PE, PF (Schmitt input)	V <sub>HY</sub>		0.2V <sub>DD</sub>		V	
Input Low Voltage XT1_IN <sup>[2]</sup>	V <sub>IL3</sub>	0	-	0.8	V	V <sub>DD</sub> = 4.5V
		0	-	0.4		V <sub>DD</sub> = 3.0V
Input High Voltage XT1_IN <sup>[2]</sup>	V <sub>IH3</sub>	3.5	-	V <sub>DD</sub> +0.2	V	V <sub>DD</sub> = 5.5V
		2.4	-	V <sub>DD</sub> +0.2		V <sub>DD</sub> = 3.0V
Input Low Voltage X32_IN <sup>[2]</sup>	V <sub>IL4</sub>	0	-	0.4	v	
Input High Voltage X32_IN <sup>[2]</sup>	V <sub>IH4</sub>	1.2		1.8	V	
Negative going threshold (Schmitt input), nRESET	V <sub>ILS</sub>	-0.5	-	0.2V <sub>DD</sub> -0.2	V	

PARAMETER	SYM.	SPECIFICATION				TEST CONDITIONS
		MIN.	TYP.	MAX.	UNIT	
Positive going threshold (Schmitt input), nRESET	V <sub>IHS</sub>	0.7V <sub>DD</sub>	-	V <sub>DD</sub> +0.5	V	
Source Current PA, PB, PC, PD, PE, PF (Quasi- bidirectional Mode)	I <sub>SR11</sub>	-300	-370	-450	μA	V <sub>DD</sub> = 4.5V, V <sub>S</sub> = 2.4V
	I <sub>SR12</sub>	-50	-70	-90	μA	V <sub>DD</sub> = 2.7V, V <sub>S</sub> = 2.2V
	I <sub>SR12</sub>	-40	-60	-80	μA	V <sub>DD</sub> = 2.5V, V <sub>S</sub> = 2.0V
Source Current PA, PB, PC, PD, PE, PF (Push-pull Mode)	I <sub>SR21</sub>	-24	-28	-32	mA	V <sub>DD</sub> = 4.5V, V <sub>S</sub> = 2.4V
	I <sub>SR22</sub>	-4	-6	-8	mA	V <sub>DD</sub> = 2.7V, V <sub>S</sub> = 2.2V
	I <sub>SR22</sub>	-3	-5	-7	mA	V <sub>DD</sub> = 2.5V, V <sub>S</sub> = 2.0V
Sink Current PA, PB, PC, PD, PE, PF (Quasi-bidirectional and Push-pull Mode)	I <sub>SK1</sub>	10	16	20	mA	V <sub>DD</sub> = 4.5V, V <sub>S</sub> = 0.45V
	I <sub>SK1</sub>	7	10	13	mA	V <sub>DD</sub> = 2.7V, V <sub>S</sub> = 0.45V
	I <sub>SK1</sub>	6	9	12	mA	V <sub>DD</sub> = 2.5V, V <sub>S</sub> = 0.45V
Brown-out Voltage with BOD_VL [1:0] = 00b	V <sub>BO2.2</sub>	2.1	2.2	2.3	V	
Brown-out Voltage with BOD_VL [1:0] = 01b	V <sub>BO2.7</sub>	2.6	2.7	2.8	V	
Brown-out voltage with BOD_VL [1:0] = 10b	V <sub>BO3.8</sub>	3.5	3.7	3.9	V	
Brown-out Voltage with BOD_VL [1:0] = 11b	V <sub>BO4.5</sub>	4.2	4.4	4.6	V	
Hysteresis range of BOD voltage	V <sub>BH</sub>	30	-	150	mV	V <sub>DD</sub> = 2.5V~5.5V

**Note:**

1. nRESET pin is a Schmitt trigger input.
2. Crystal Input is a CMOS input.
3. Pins of PA, PB, PC, PD, PE and PF can source a transition current when they are being externally driven from 1 to 0. In the condition of V<sub>DD</sub> = 5.5 V, the transition current reaches its maximum value when V<sub>IN</sub> approximates to 2 V.

### 6.3 AC Electrical Characteristics

#### 6.3.1 External 4~24 MHz High Speed Oscillator

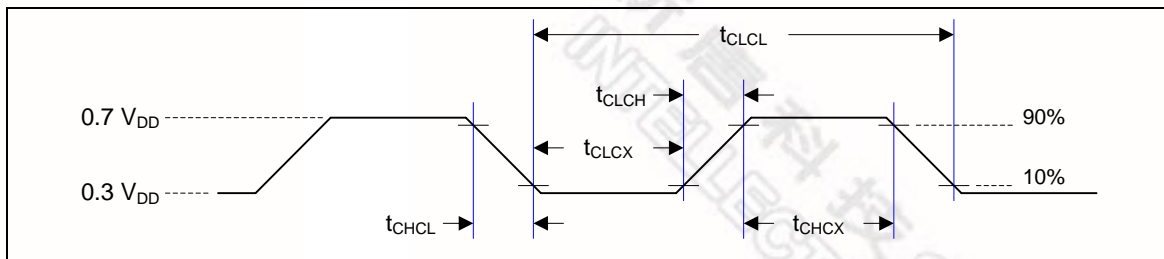

Note: Duty cycle is 50%.

SYMBOL	PARAMETER	CONDITION	MIN.	TYP.	MAX.	UNIT
$t_{CHCX}$	Clock High Time		10	-	-	nS
$t_{CLCX}$	Clock Low Time		10	-	-	nS
$t_{CLCH}$	Clock Rise Time		2	-	15	nS
$t_{CHCL}$	Clock Fall Time		2	-	15	nS

#### 6.3.2 External 4~24 MHz High Speed Crystal

PARAMETER	CONDITION	MIN.	TYP..	MAX.	UNIT
Operation Voltage $V_{DD}$	-	2.5	-	5.5	V
Temperature	-	-40	-	85	°C
Operating Current	12 MHz at $V_{DD} = 5V$	-	1	-	mA
Clock Frequency	External crystal	4		24	MHz

##### 6.3.2.1 Typical Crystal Application Circuits

CRYSTAL	C1	C2	R
4 MHz ~ 24 MHz	10~20pF	10~20pF	without

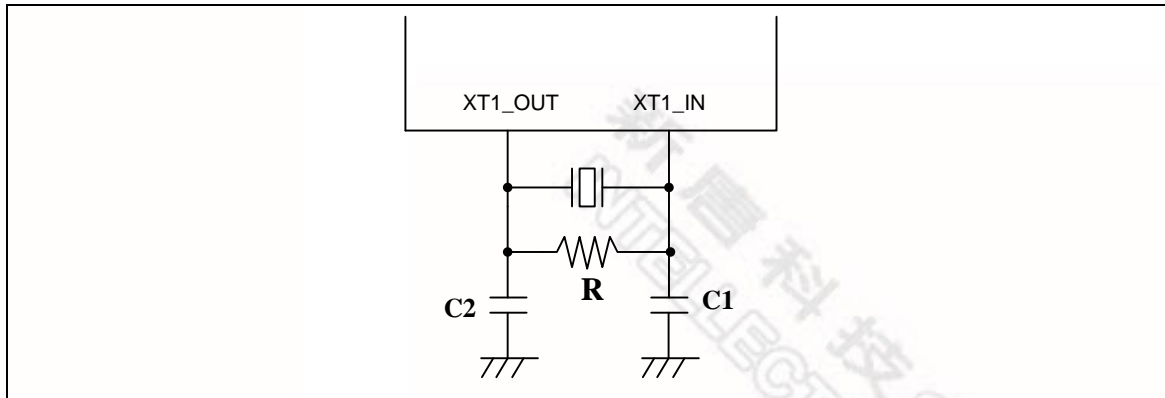

Figure 6-1 Typical Crystal Application Circuit

### 6.3.3 External 32.768 kHz Low Speed Crystal Oscillator

PARAMETER	CONDITION	MIN.	TYP.	MAX.	UNIT
Operation Voltage $V_{DD}$	-	2.5	-	5.5	V
Operation Temperature	-	-40	-	85	°C
Operation Current	32.768KHz at $V_{DD}=5V$		1.5		$\mu A$
Clock Frequency	External crystal	-	32.768	-	kHz

### 6.3.4 Internal 22.1184 MHz High Speed Oscillator

PARAMETER	CONDITION	MIN.	TYP.	MAX.	UNIT
Operation Voltage $V_{DD}$	-	2.5	-	5.5	V
Center Frequency	-	-	22.1184	-	MHz
Calibrated Internal Oscillator Frequency	+25°C; $V_{DD} = 5 V$	-1	-	+1	%
	-40°C ~ +85°C; $V_{DD}=2.5 V \sim 5.5 V$	-3	-	+3	%
Operation Current	$V_{DD} = 5 V$	-	500	-	$\mu A$

### 6.3.5 Internal 10 kHz Low Speed Oscillator

PARAMETER	CONDITION	MIN.	TYP.	MAX.	UNIT
Operation Voltage $V_{DD}$	-	2.5	-	5.5	V
Center Frequency	-	-	10	-	kHz
Calibrated Internal Oscillator Frequency	+25°C; $V_{DD} = 5 V$	-30	-	+30	%





	-40°C ~ +85°C; V <sub>DD</sub> =2.5 V~5.5 V	-50	-	+50	%
--	------------------------------------------------	-----	---	-----	---

## 6.4 Analog Characteristics

### 6.4.1 12-bit SARADC Specification

SYMBOL	PARAMETER	MIN.	TYP.	MAX.	UNIT
-	Resolution	-	-	12	Bit
DNL	Differential nonlinearity error	-	-1~2	-1~4	LSB
INL	Integral nonlinearity error	-	±2	±4	LSB
EO	Offset error	-	±1	10	LSB
EG	Gain error (Transfer gain)	-	1	1.005	-
-	Monotonic	Guaranteed			
F <sub>ADC</sub>	ADC clock frequency (AV <sub>DD</sub> = 5V/3V)	-	-	16/8	MHz
F <sub>S</sub>	Sample rate	-	-	760	kSPS
V <sub>DDA</sub>	Supply voltage	3	-	5.5	V
I <sub>DD</sub>	Supply current (Avg.)	-	0.5	-	mA
I <sub>DDA</sub>		-	1.5	-	mA
V <sub>REF</sub>	Reference voltage	3	-	V <sub>DDA</sub>	V
I <sub>REF</sub>	Reference current (Avg.)	-	1	-	mA
V <sub>IN</sub>	Input voltage	0	-	V <sub>REF</sub>	V

### 6.4.2 LDO and Power Management Specification

PARAMETER	MIN.	TYP.	MAX.	UNIT	NOTE
Input Voltage V <sub>DD</sub>	2.5		5.5	V	V <sub>DD</sub> input voltage
Output Voltage	1.62	1.8	1.98	V	V <sub>DD</sub> > 2.5 V
Operating Temperature	-40	25	85	°C	
Cbp	-	1	-	μF	R <sub>ESR</sub> = 1 Ω

**Note:**

1. It is recommended that a 10 μF or higher capacitor and a 100 nF bypass capacitor are connected between V<sub>DD</sub> and the closest V<sub>SS</sub> pin of the device.
2. To ensure power stability, a 1 μF or higher capacitor must be connected between LDO\_CAP pin and the closest V<sub>SS</sub> pin of the device.

### 6.4.3 Low Voltage Reset Specification

PARAMETER	CONDITION	MIN.	TYP.	MAX.	UNIT
Operation Voltage	-	0	-	5.5	V
Quiescent Current	$V_{DD}=5.5\text{ V}$	-	1	5	$\mu\text{A}$
Operation Temperature	-	-40	25	85	$^{\circ}\text{C}$
Threshold Voltage	Temperature=25 $^{\circ}\text{C}$	1.7	2.0	2.3	V
	Temperature=-40 $^{\circ}\text{C}$	-	2.4	-	V
	Temperature=85 $^{\circ}\text{C}$	-	1.6	-	V
Hysteresis	-	0	0	0	V

### 6.4.4 Brown-out Detector Specification

PARAMETER	CONDITION	MIN.	TYP.	MAX.	UNIT
Operation Voltage	-	0	-	5.5	V
Operation Temperature	-	-40	25	85	$^{\circ}\text{C}$
Quiescent Current	$AV_{DD}=5.5\text{ V}$	-	-	125	$\mu\text{A}$
Brown-out Voltage	BOD_VL[1:0]=11	4.2	4.4	4.6	V
	BOD_VL [1:0]=10	3.5	3.7	3.9	V
	BOD_VL [1:0]=01	2.6	2.7	2.8	V
	BOD_VL [1:0]=00	2.1	2.2	2.3	V
Hysteresis	-	30	-	150	mV

### 6.4.5 Power-on Reset Specification

PARAMETER	CONDITION	MIN.	TYP.	MAX.	UNIT
Operation Temperature	-	-40	25	85	$^{\circ}\text{C}$
Reset Voltage	V+	-	2	-	V
Quiescent Current	$V_{in} > \text{reset voltage}$	-	1	-	nA

#### 6.4.6 Temperature Sensor Specification

PARAMETER	CONDITION	MIN.	TYP.	MAX.	UNIT
Operation Voltage <sup>[1]</sup>		2.5	-	5.5	V
Operation Temperature		-40	-	85	°C
Current Consumption		6.4	-	10.5	μA
Gain			-1.76		mV/°C
Offset Voltage	Temp=0 °C		720		mV

**Note:** Internal operation voltage comes from internal LDO.

#### 6.4.7 Comparator Specification

PARAMETER	CONDITION	MIN.	TYP.	MAX.	UNIT
Operation Voltage AV <sub>DD</sub>	-	2.5		5.5	V
Operation Temperature	-	-40	25	85	°C
Operation Current	V <sub>DD</sub> =3.0 V	-	20	40	μA
Input Offset Voltage	-	-	5	15	mV
Output Swing	-	0.1	-	V <sub>DDA</sub> -0.1	V
Input Common Mode Range	-	0.1	-	V <sub>DDA</sub> -1.2	V
DC Gain	-	-	70	-	dB
Propagation Delay	V <sub>CM</sub> = 1.2 V and V <sub>DIFF</sub> = 0.1 V	-	200	-	ns
Comparison Voltage	20 mV at V <sub>CM</sub> =1 V 50 mV at V <sub>CM</sub> =0.1 V 50 mV at V <sub>CM</sub> =V <sub>DD</sub> -1.2 10 mV for non-hysteresis	10	20	-	mV
Hysteresis	V <sub>CM</sub> =0.4 V ~ V <sub>DD</sub> -1.2 V	-	±10	-	mV
Wake-up Time	C <sub>INP</sub> = 1.3 V C <sub>INN</sub> = 1.2 V	-	-	2	μs

## 6.4.8 USB PHY Specification

### 6.4.8.1 USB DC Electrical Characteristics

SYMBOL	PARAMETER	CONDITION	MIN.	TYP.	MAX.	UNIT
V <sub>IH</sub>	Input High (driven)		2.0			V
V <sub>IL</sub>	Input Low				0.8	V
V <sub>DI</sub>	Differential Input Sensitivity	PADP-PADM	0.2			V
V <sub>CM</sub>	Differential Common-mode Range	Includes V <sub>DI</sub> range	0.8		2.5	V
V <sub>SE</sub>	Single-ended Receiver Threshold		0.8		2.0	V
	Receiver Hysteresis			200		mV
V <sub>OL</sub>	Output Low (driven)		0		0.3	V
V <sub>OH</sub>	Output High (driven)		2.8		3.6	V
V <sub>CRS</sub>	Output Signal Cross Voltage		1.3		2.0	V
R <sub>PU</sub>	Pull-up Resistor		1.425		1.575	kΩ
V <sub>TRM</sub>	Termination Voltage for Upstream Port Pull-up (RPU)		3.0		3.6	V
Z <sub>DRV</sub>	Driver Output Resistance	Steady state drive*		10		Ω
C <sub>IN</sub>	Transceiver Capacitance	Pin to GND			20	pF

\*Driver output resistance doesn't include series resistor resistance.

### 6.4.8.2 USB Full-Speed Driver Electrical Characteristics

SYMBOL	PARAMETER	CONDITION	MIN.	TYP.	MAX.	UNIT
T <sub>FR</sub>	Rise Time	C <sub>L</sub> =50p	4		20	ns
T <sub>FF</sub>	Fall Time	C <sub>L</sub> =50p	4		20	ns
T <sub>FRFF</sub>	Rise and Fall Time Matching	T <sub>FRFF</sub> =T <sub>FR</sub> /T <sub>FF</sub>	90		111.11	%

### 6.4.8.3 USB Power Dissipation

SYMBOL	PARAMETER	CONDITION	MIN.	TYP.	MAX.	UNIT
I <sub>VBUS</sub>	USB_VBUS Current (Steady State)	Standby		50		μA

## 6.4.8.4 USB LDO Specification

SYMBOL	PARAMETER	CONDITION	MIN.	TYP.	MAX.	UNIT
USB_VBUS	USB_VBUS Pin Input Voltage		4.0	5.0	5.5	V
USB_VDD33_CAP	LDO Output Voltage		3.0	3.3	3.6	V
C <sub>bp</sub>	External Bypass Capacitor			1.0	-	uF

## 6.5 Flash DC Electrical Characteristics

SYMBOL	PARAMETER	CONDITION	MIN.	TYP.	MAX.	UNIT
V <sub>DD</sub>	Supply Voltage		1.62	1.8	1.98	V <sup>[2]</sup>
N <sub>ENDUR</sub>	Endurance		100000			cycles <sup>[1]</sup>
T <sub>RET</sub>	Data Retention	At 85°C	10			year
T <sub>ERASE</sub>	Page Erase Time			2		ms
T <sub>MER</sub>	Mass Erase Time			10		ms
T <sub>PROG</sub>	Program Time			20		μs
I <sub>DD1</sub>	Read Current		-	0.15	0.5	mA/MHz
I <sub>DD2</sub>	Program/Erase Current				7	mA
I <sub>PD</sub>	Power Down Current		-	1	20	μA

1. Number of program/erase cycles.
2. V<sub>DD</sub> is source from chip LDO output voltage.
3. This table is guaranteed by design, not test in production.

7 PACKAGE DIMENSIONS

7.1 100-pin LQFP (14x14x1.4 mm footprint 2.0 mm)

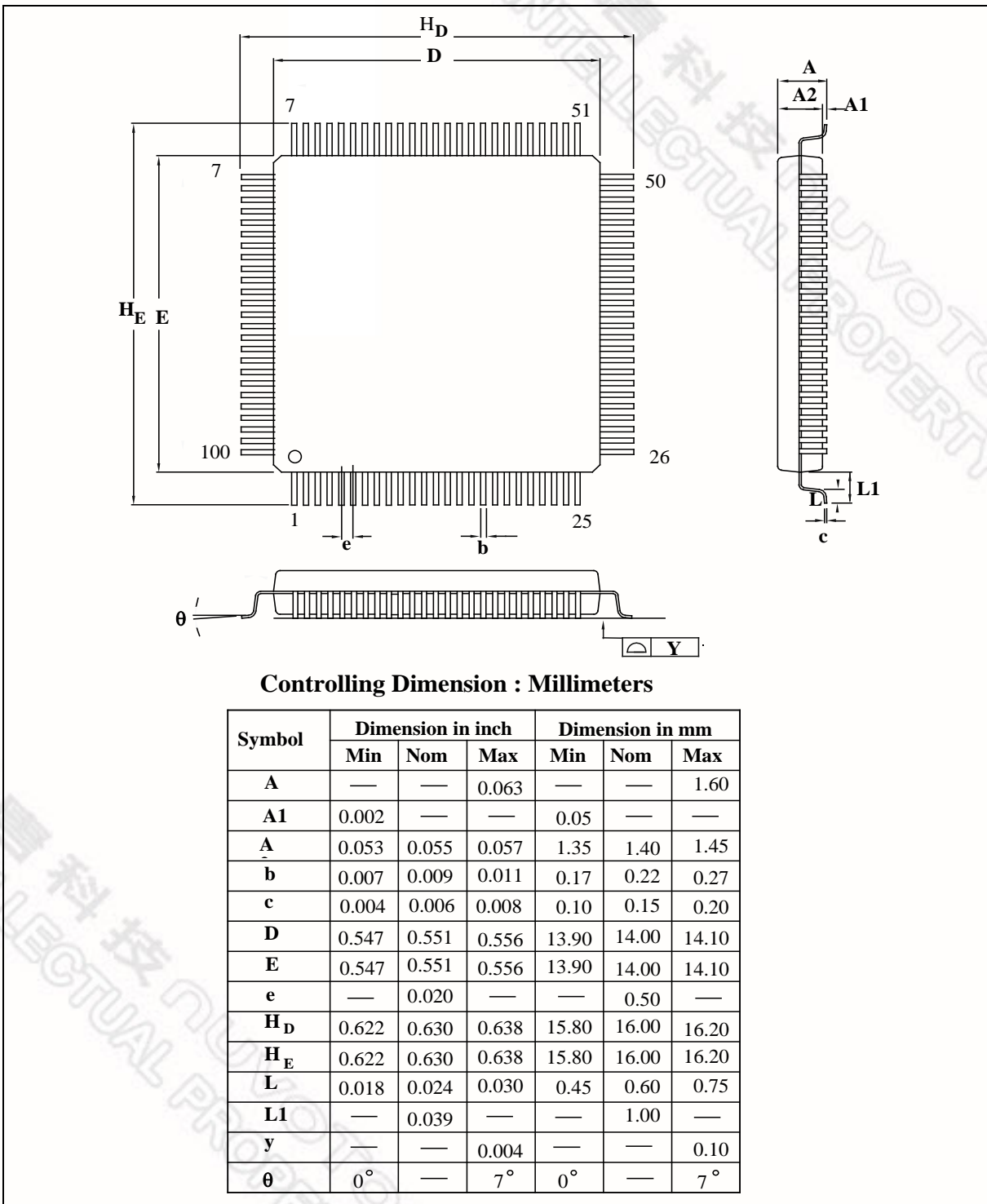

7.2 64-pin LQFP (7x7x1.4 mm footprint 2.0 mm)

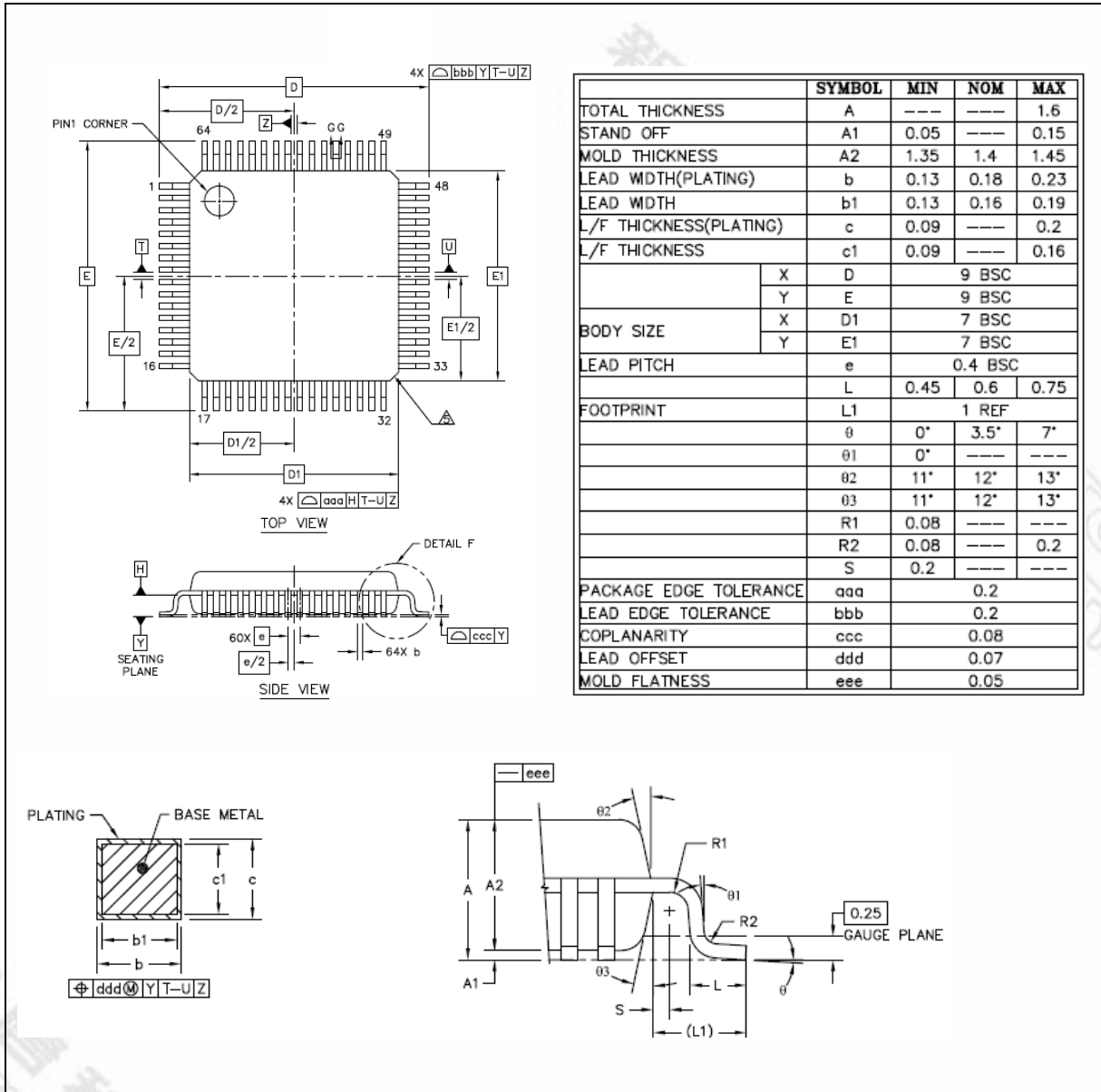

	SYMBOL	MIN	NOM	MAX
TOTAL THICKNESS	A	---	---	1.6
STAND OFF	A1	0.05	---	0.15
MOLD THICKNESS	A2	1.35	1.4	1.45
LEAD WIDTH(PLATING)	b	0.13	0.18	0.23
LEAD WIDTH	b1	0.13	0.16	0.19
L/F THICKNESS(PLATING)	c	0.09	---	0.2
L/F THICKNESS	c1	0.09	---	0.16
BODY SIZE	X	D	9 BSC	
	Y	E	9 BSC	
BODY SIZE	X	D1	7 BSC	
	Y	E1	7 BSC	
LEAD PITCH	e	0.4 BSC		
FOOTPRINT	L	0.45	0.6	0.75
	L1	1 REF		
	θ	0°	3.5°	7°
	θ1	0°	---	---
	θ2	11°	12°	13°
	θ3	11°	12°	13°
	R1	0.08	---	---
	R2	0.08	---	0.2
	S	0.2	---	---
PACKAGE EDGE TOLERANCE	aaa	0.2		
LEAD EDGE TOLERANCE	bbb	0.2		
COPLANARITY	ccc	0.08		
LEAD OFFSET	ddd	0.07		
MOLD FLATNESS	eee	0.05		

NUMICRO™ NUC200/220 DATASHEET



7.3 48-pin LQFP (7x7x1.4 mm footprint 2.0 mm)

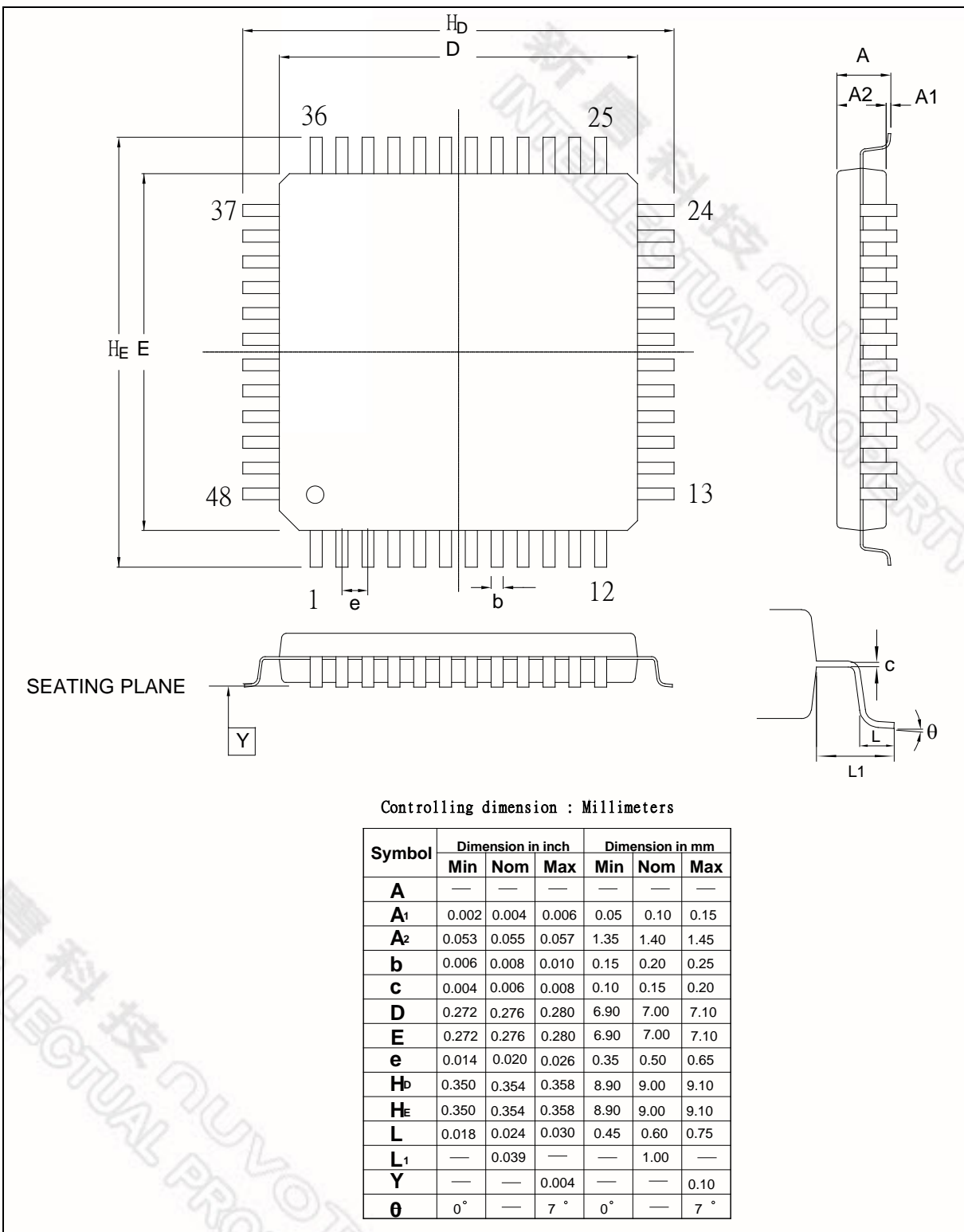

## 8 REVISION HISTORY

Revision	Date	Description
V1.00	June 07, 2012	Initial release

### Important Notice

Nuvoton Products are neither intended nor warranted for usage in systems or equipment, any malfunction or failure of which may cause loss of human life, bodily injury or severe property damage. Such applications are deemed, "Insecure Usage".

Insecure usage includes, but is not limited to: equipment for surgical implementation, atomic energy control instruments, airplane or spaceship instruments, the control or operation of dynamic, brake or safety systems designed for vehicular use, traffic signal instruments, all types of safety devices, and other applications intended to support or sustain life.

All Insecure Usage shall be made at customer's risk, and in the event that third parties lay claims to Nuvoton as a result of customer's Insecure Usage, customer shall indemnify the damages and liabilities thus incurred by Nuvoton.

Please note that all data and specifications are subject to change without notice.  
All the trademarks of products and companies mentioned in this datasheet belong to their respective owners.

## X-ON Electronics

Largest Supplier of Electrical and Electronic Components

*Click to view similar products for [8-bit Microcontrollers - MCU category](#):*

*Click to view products by [Nuvoton manufacturer](#):*

Other Similar products are found below :

[009936B](#) [CY8C20524-12PVXIT](#) [CY8C28433-24PVXIT](#) [MB95F012KPFT-G-SNE2](#) [MB95F013KPMC-G-SNE2](#) [MB95F263KPF-G-SNE2](#)  
[MB95F264KPFT-G-SNE2](#) [MB95F398KPMC-G-SNE2](#) [MB95F478KPMC2-G-SNE2](#) [MB95F562KPF-G-SNE2](#) [MB95F564KPF-G-SNE2](#)  
[MB95F634KPMC-G-SNE2](#) [MB95F636KWQN-G-SNE1](#) [MB95F696KPMC-G-SNE2](#) [MB95F698KPMC1-G-SNE2](#) [MB95F698KPMC2-G-](#)  
[SNE2](#) [MB95F698KPMC-G-SNE2](#) [MB95F818KPMC1-G-SNE2](#) [MC908JK1ECDWER](#) [MC9S08PA32AVLD](#) [MC9S08PT60AVLD](#)  
[R5F1076CMSPV0](#) [R5F5631ECDFBV0](#) [C8051F389-B-GQ](#) [C8051F392-A-GMR](#) [ISD-ES1600\\_USB\\_PROG](#) [901015X](#) [S9S08SL8F1CTJR](#)  
[STM8TL53G4U6](#) [PIC16F877-04/P-B](#) [R5F10Y17ASP#30](#) [CY8C3MFIDOCK-125](#) [403708R](#) [MB95F354EPF-G-SNE2](#) [MB95F564KPFT-G-](#)  
[SNE2](#) [MB95F564KWQN-G-SNE1](#) [MB95F636KP-G-SH-SNE2](#) [MB95F636KPMC-G-SNE2](#) [MB95F694KPMC-G-SNE2](#) [MB95F778JPMC1-](#)  
[G-SNE2](#) [MB95F818KPMC-G-SNE2](#) [MC908QY8CDWER](#) [MC9S08PT16AVLD](#) [MC9S08PT32AVLH](#) [MC9S08PT60AVLC](#)  
[MC9S08PT60AVLH](#) [C8051F500-IQR](#) [400801H](#) [LC87F0G08AUJA-AH](#) [026923G](#)