

PRODUCT NUMBER
20020302-XXXXXXLF

20020302-□ □ □ □ B 0 □ L F

PITCH

D: 3.81 mm
G: 5.00 mm
H: 5.08 mm

POLES

02: 2 POLES
03: 3 POLES
.....
24: 24 POLES

LF : DENOTED RoHS COMPATIBLE

1 : STANDARD PRODUCT
W/ BOX PACKING

HOUSING CODE

CODE	COLOR	AVAILABILITY
1	GREEN(RAL 6018/T)	STANDARD
2	BLACK	ON REQUEST ONLY
3	GREY(RAL 7004/P)	ON REQUEST ONLY
4	BLUE(RAL 5015/A)	ON REQUEST ONLY

PROPERTY TABLE				
FCI SERIES NAME		09-381	09-500	09-508
PITCH (mm)		3.81	5.00	5.08
VOLTAGE RATING (VAC)		300	300	300
CURRENT RATING (A)		6	10	10
APPLICABLE WIRE RANGE (AWG)	1-WIRE	16~26	14~24	14~24
	2-WIRE	NA	NA	NA
WIRE CROSS SECTION (mm ²)	SOLID	1-WIRE	1.0	1.5
		2-WIRE	NA	NA
	STRANDED	1-WIRE	1.0	1.5
		2-WIRE	NA	NA
OPENING CONTACT HOUSING(mm ²)		1.7x1.7	2.4x2.4	2.4x2.4
WIRE STRIP LENGTH(mm)		9~10	9~10	9~10
WITHSTANDING VOLTAGE (kV)		1.6	1.6	1.6
OPERATING TEMP. (°C)		-40~+115	-40~+115	-40~+115
SOLDERING TEMP. (°C)		250±10 (5 sec.)	250±10 (5 sec.)	250±10 (5 sec.)
POLES AVAILABLE		02~24	02~24	02~24
SAFETY CERTIFICATE				

NOTES:

- MATERIALS
1-1 HOUSING: THERMALPLASTIC RESIN, UL 94V-0 RATED.
1-2 COVER: THERMALPLASTIC RESIN, UL 94V-0 RATED.
1-3 LEVER: THERMALPLASTIC RESIN, UL 94V-0 RATED.
1-4 TERMINAL: COPPER ALLOY, TIN PLATED.
1-5 SPRING CLAMP: STAINLESS STEEL.
- PRODUCT SPECIFICATION REFER TO FCI GS-12-625.
- PRODUCT PACKING SPECIFICATION REFER TO FCI GS-14-1394.
- FCI, SAFETY CERTIFICATE LOGO AND SERIES NAME TO BE SHOWN ON PRODUCT SURFACE.
- THE PRODUCTS WHERE THE PART NUMBER END IN "LF" MEET THE EUROPEAN UNION DIRECTIVE AND OTHER COUNTRY REGULATIONS AS DESCRIBED IN GS-22-008.
- RECOMMENDED SOLDERING PROCESS BY WAVE SOLDER.

mat'l. code		surface ASME Y14.5 ✓		tolerance ASME Y14.5		projection		product family	
ltr		ecn no		dr		date		TERMINAL BLOCK	
A		T10-0191		WL		122010		title	
								TERMINAL BLOCK	
								FIXED SIGNAL PLUG, VERTICAL WIRE INLET	
								scale	
								dwg no	
								sheet 1 of 4 size	
								20020302	
								A4	
								type	
								CUSTOMER Drawing	
sheet index		revision sheet		A		A		A	
				1		2		3	



PRODUCT NUMBER	SERIES NAME	PITCH
20020302-DXXXXXXLF	09-381	3.81 mm

N = Number of poles
 Dim L = (N x 3.81 [.150]) + 2.50 [.098]
 Dim B = (N - 1) x 3.81 [.150]

POLES	Dim L	Dim B
2-6p	±0.15 [.006]	±0.10 [.004]
7-12p	±0.20 [.008]	±0.20 [.008]
13-18p	±0.30 [.012]	±0.25 [.010]
19-24p	±0.40 [.016]	±0.30 [.012]

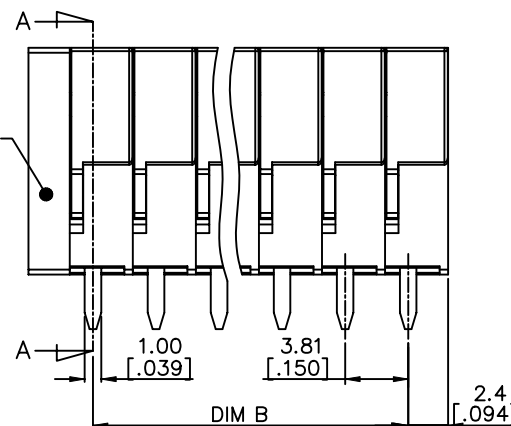
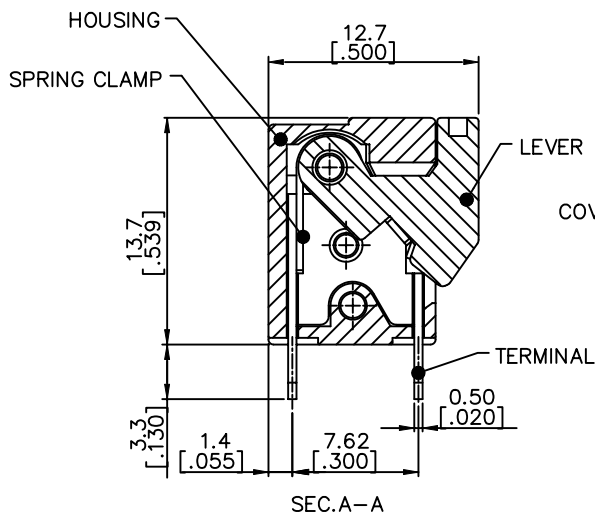
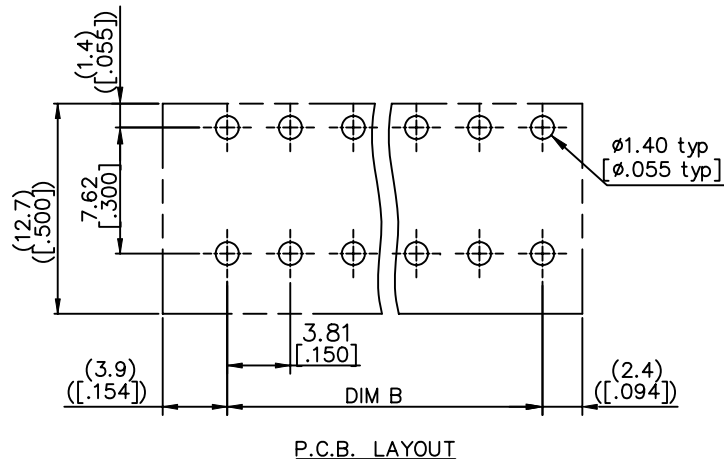
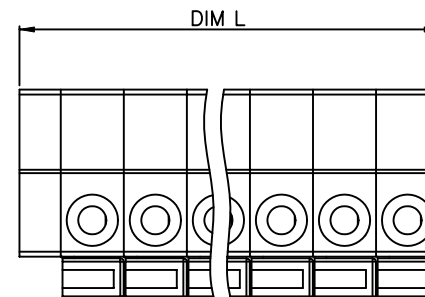

mat'l. code		surface ASME Y14.5 ✓	tolerance ASME Y14.5	projection 	product family TERMINAL BLOCK
ltr	ecn no	dr	date	title TERMINAL BLOCK FIXED SIGNAL PLUG, VERTICAL WIRE INLET	
A		angles X°±1'		MM [INCH]	scale
		dr WENDY CHEN 110910		dwg no 20020302 sheet 2 of 4 size A4	
		enr JASON HSU 110910		type CUSTOMER Drawing	
		chr JASON HSU 110910			
		appd JASON HSU 110910			
sheet index	revision sheet				



PRODUCT NUMBER	SERIES NAME	PITCH
20020302-GXXXXXXLF	09-500	5.00 mm

N = Number of poles
 Dim L = (N x 5.0 [.197]) + 2.54 [.100]
 Dim B = (N - 1) x 5.0 [.197]

POLES	Dim L	Dim B
2-6p	±0.15 [.006]	±0.10 [.004]
7-12p	±0.20 [.008]	±0.20 [.008]
13-18p	±0.30 [.012]	±0.25 [.010]
19-24p	±0.40 [.016]	±0.30 [.012]

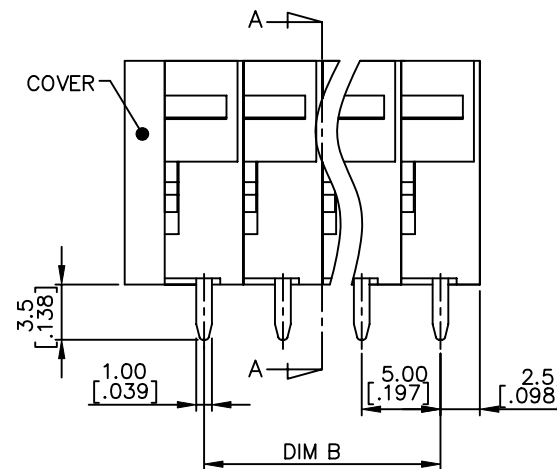
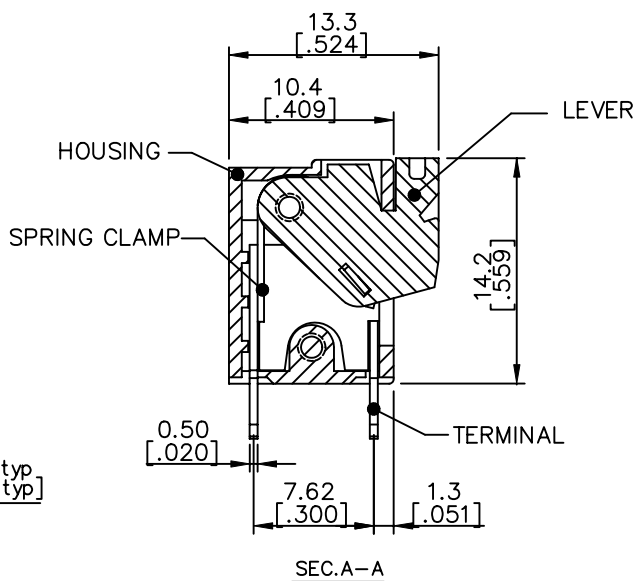
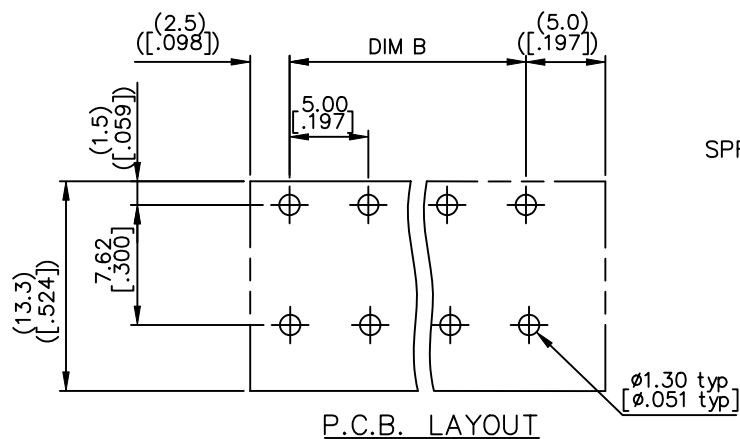
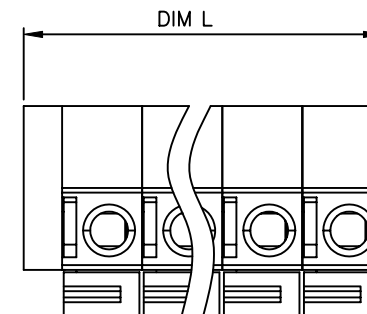

mat'l. code		surface ASME Y14.5	tolerance ASME Y14.5	projection 	product family TERMINAL BLOCK
ltr	ecn no	dr	date	title	
tolerances unless otherwise specified				 scale	TERMINAL BLOCK FIXED SIGNAL PLUG, VERTICAL WIRE INLET
angles		X ± 0.5			
X° ± 1'		X.X ± 0.3			
		X.XX ± 0.1		dwg no	
		dr WENDY CHEN 110910		sheet 3 of 4 size	
		enr JASON HSU 110910		20020302 A4	
		chr JASON HSU 110910		type	
		appd JASON HSU 110910		CUSTOMER Drawing	
sheet index	revision sheet				



PRODUCT NUMBER	SERIES NAME	PITCH
20020302-HXXXXXLf	09-508	5.08 mm

N = Number of poles
 Dim L = (N x 5.08 [.200]) + 2.54 [.100]
 Dim B = (N - 1) x 5.08 [.200]

POLES	Dim L	Dim B
2-6p	±0.15 [.006]	±0.10 [.004]
7-12p	±0.20 [.008]	±0.20 [.008]
13-18p	±0.30 [.012]	±0.25 [.010]
19-24p	±0.40 [.016]	±0.30 [.012]

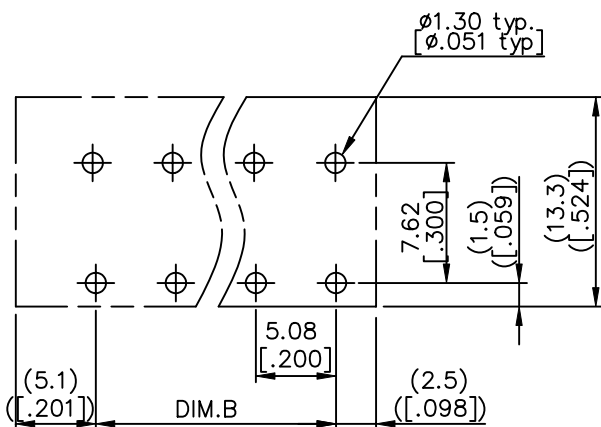
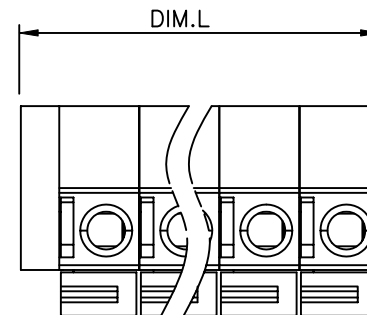

P.C.B. LAYOUT

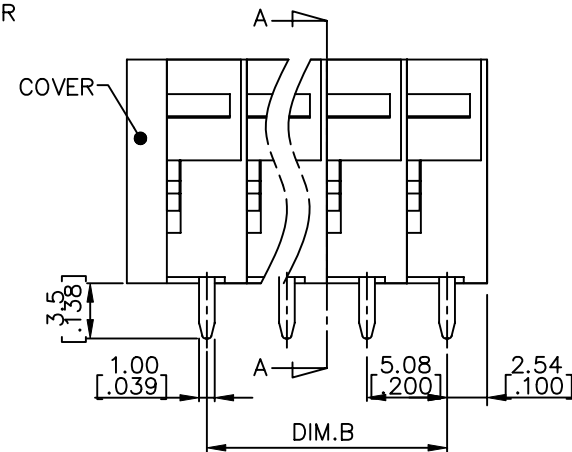
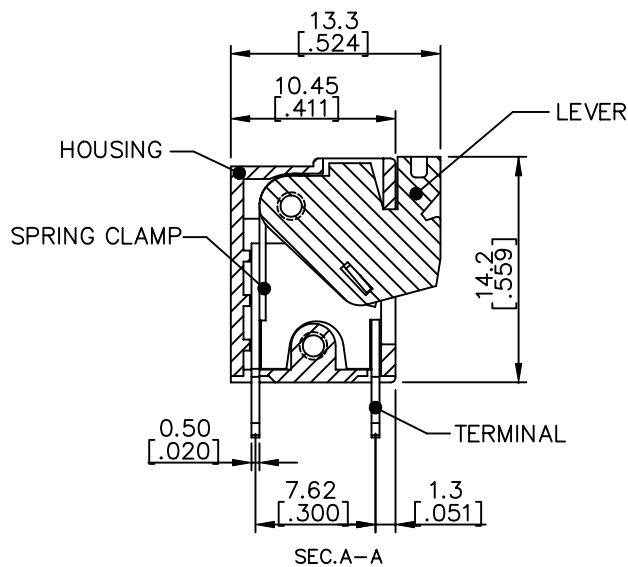

mat'l. code		surface ASME Y14.5	tolerance ASME Y14.5	projection MM INCH	product family TERMINAL BLOCK
ltr	ecn no	dr	date	title TERMINAL BLOCK FIXED SIGNAL PLUG, VERTICAL WIRE INLET	
A				scale	sheet 4 of 4 size
					20020302 A4
		dr	WENDY CHEN	110910	type CUSTOMER Drawing
		enr	JASON HSU	110910	
		chr	JASON HSU	110910	
		appd	JASON HSU	110910	
sheet index	revision sheet				

X-ON Electronics

Largest Supplier of Electrical and Electronic Components

Click to view similar products for [Fixed Terminal Blocks](#) category:

Click to view products by [FCT Electronics](#) manufacturer:

Other Similar products are found below :

[00175550202](#) [MBE-1512](#) [MBE-1520](#) [MBE-154](#) [MBE-156](#) [MBES-1510](#) [MBES-153](#) [MBES-156](#) [MH-2512](#) [MHE-132](#) [MHE-133](#) [MHE-163](#)
[MI-254 \(35\)](#) [MI-272](#) [8739](#) [880507](#) [880508](#) [MPT-275](#) [1546551-6](#) [ELM023100](#) [ELM10110G](#) [ELVD12100](#) [BA311TU](#) [BA411SU](#) [MV-152](#)
[MV-253/NCNOC](#) [MV-254-D](#) [MV-255](#) [MV-462](#) [MV-472](#) [MV-493](#) [MVE-252](#) [MVE-253](#) [MVE-258](#) [MVE-273](#) [MVEB-153](#) [1700096](#)
[1702246](#) [1705142](#) [1712417](#) [1713020](#) [1713088](#) [1776118-2](#) [1790852](#) [1-796689-8](#) [1-796692-6](#) [1800001](#) [1800114](#) [1823215](#) [1838462](#)