

# Pyroelectric Infrared Sensors



Cat.No.S21E-4

**muRata** *Innovator  
in Electronics*  
Murata  
Manufacturing Co., Ltd.

# CONTENTS

HIC® in this catalog are the trademarks of Murata Manufacturing Co., Ltd.

<b>Part Numbering</b>	1
<b>1 Dual Type Pyroelectric Infrared Sensor IRA-E700 Series</b>	2
<b>2 Quad Type Pyroelectric Infrared Sensor IRA-E900 Series</b>	3
<b>3 Quad Type Pyroelectric Infrared Sensor IRA-E940ST1 Series</b>	4
<b>4 Temperature Compensation Single Type Pyroelectric Infrared Sensor IRA-E420 Series</b>	5
<b>Pyroelectric Infrared Sensor IRA Series Characteristics Data</b>	7
<b>Fresnel Lens</b>	10
<b>Notice</b>	13

## ● Part Numbering

### Pyroelectric Infrared Sensor

(Part Number) 

IR	A-	E710ST	1
----	----	--------	---

①    ②    ③    ④

- ① Product ID
- ② Type
- ③ Characteristics
- ④ Individual Specification Code

\* Part Number shows only an example which might be different from actual part number.

\* "③ Characteristics" and "④ Individual Specification Code" might have different digit number from actual Part Number.

# Pyroelectric Infrared Sensors



## Dual Type Pyroelectric Infrared Sensor IRA-E700 Series

Pyroelectric infrared sensors, IRA series, exhibit high sensitivity and reliable performance made possible by Murata's ceramic technology and Hybrid IC technique expertise developed over many years.

IRA-E700 series realizes cost benefits and higher performance with a new infrared sensor element of improved material parameters and fabrication.

IRA-E700 series is available in two types.

IRA-E710ST0 has enhanced immunity to RFI (Radio Frequency Interference).

### ■ Features

1. High sensitivity and excellent S/N ratio
2. High stability to temperature changes
3. Slight movement can be detectable.
4. High immunity to external noise (Vibration, RFI etc.)
5. Custom design is available.
6. Higher in cost-performance

### ■ Applications

1. Security
2. Lighting appliances
3. Household or other appliances

### ■ Rating (25°C)

Part Number	IRA-E700ST0	IRA-E710ST0
Responsivity (500K, 1Hz, 1Hz)	4.3mV <sub>p-p</sub> (Typ.)	
Field of View	$\theta_1=\theta_2=45^\circ$	
Optical Filter	5μm long-pass	
Electrode	(2.0×1.0mm)×2	
Supply Voltage	2 to 15V	
Operating Temperature	-40 to 70°C	
Storage Temperature	-40 to 85°C	

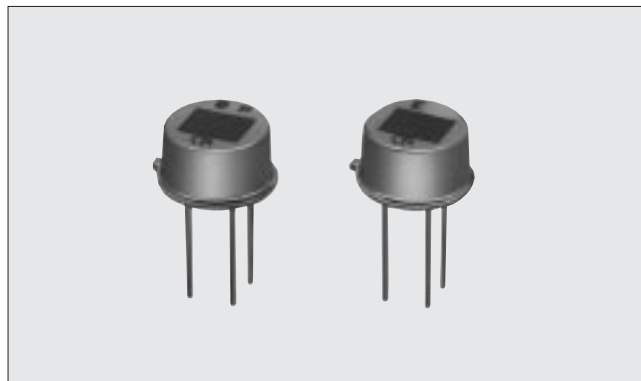

### ■ Dimensions & Circuit Diagrams

General Tolerance : ±0.2 (in mm)

Pyroelectric element (in mm)

IRA-E700ST0

IRA-E710ST0

# Pyroelectric Infrared Sensors



## Quad Type Pyroelectric Infrared Sensor IRA-E900 Series

Pyroelectric infrared sensors, IRA series, exhibit high sensitivity and reliable performance made possible by Murata's ceramic technology and Hybrid IC technique expertise developed over many years.  
IRA-E900 series realizes cost benefits and higher performance with a new infrared sensor element of improved material parameters and fabrication.  
IRA-E900 series is available in two types.  
IRA-E910ST1 has enhanced immunity to RFI (Radio Frequency Interference).

### ■ Features

1. High sensitivity and excellent S/N ratio
2. High stability to temperature changes
3. Slight movement can be detectable.
4. Non directional sensing with wide F.O.V.
5. High immunity to external noise (Vibration, RFI etc.)
6. Custom design is available.
7. Higher in cost-performance

### ■ Applications

1. Security
2. Lighting appliances
3. Household or other appliances

### ■ Rating (25°C)

Part Number	IRA-E900ST1	IRA-E910ST1
Responsivity (500K, 1Hz, 1Hz)	3.3mV <sub>p-p</sub> (Typ.)	
Field of View	$\theta_1 = \theta_2 = 41^\circ$	
Optical Filter	5μm long-pass	
Electrode	(1.1×1.1mm)×4	
Supply Voltage	3 to 15V	
Operating Temperature	-25 to 55°C	
Storage Temperature	-40 to 85°C	

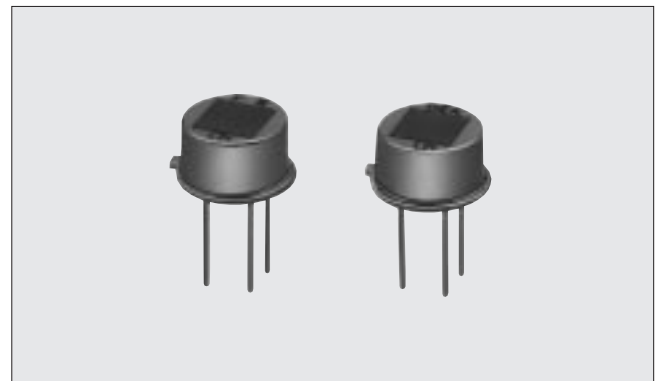

### ■ Dimensions & Circuit Diagrams

Technical drawings showing dimensions and circuit diagrams for IRA-E900ST1 and IRA-E910ST1 sensors.

Dimensions (in mm):

- Top view: 4.7±0.1 (width), 9.2 (height)
- Side view: 41° (field of view angle), 4.7 (total height), 3.6 (height to top of stem), 11.0±0.2 (height to bottom of stem), 0.45±0.05 (lead diameter)
- Bottom view: 5.08±0.05 (width), 9 (width to center of pins), 1.1 (pin spacing)

\*Specified on the bottom of stem

General Tolerance : ±0.2 (in mm)

Pyroelectric element dimensions (in mm): 1.1 (width), 1.0 (width), 1.1 (width), 1.1 (height), 1.1 (height)

Circuit Diagrams:

- IRA-E900ST1: Shows a pyroelectric element connected to a resistor (RG) and a transistor circuit. Terminals are labeled d, s, and g.
- IRA-E910ST1: Shows a pyroelectric element connected to a resistor (RG) and a transistor circuit with a capacitor. Terminals are labeled d, s, and g.

# Pyroelectric Infrared Sensors



## Quad Type Pyroelectric Infrared Sensor IRA-E940ST1 Series

3

Pyroelectric infrared sensors, IRA series, exhibit high sensitivity and reliable performance made possible by Murata's ceramic technology and Hybrid IC technique expertise developed over many years.  
IRA-E940ST1 realizes cost benefits and higher performance with a new infrared sensor element of improved material parameters and fabrication.  
IRA-E940ST1 which has quad elements and 2 outputs will detect the human body more correctly with OR/AND logic circuit.

### ■ Features

1. High sensitivity and excellent S/N ratio
2. High stability to temperature changes
3. High immunity to external noise (Vibration, RFI etc.)
4. Higher in cost-performance
5. Custom design is available.

### ■ Applications

1. Security
2. Lighting appliances
3. Household or other appliances

### ■ Rating (25°C)

Part Number	IRA-E940ST1
Responsivity (500K, 1Hz, 1Hz)	3.3mV <sub>p-p</sub> (Typ.)
Field of View	$\theta_1=55^\circ, \theta_2=50^\circ$
Optical Filter	5 $\mu$ m long-pass
Electrode	(1.35 $\times$ 1.0mm) $\times$ 4
Supply Voltage	2 to 15V
Operating Temperature	-25 to 55°C
Storage Temperature	-40 to 85°C

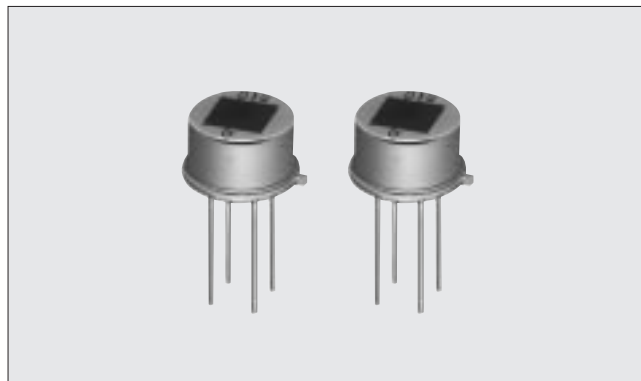

### ■ Dimensions & Circuit Diagrams

General Tolerance :  $\pm 0.2$  (in mm)

Pyroelectric element

# Pyroelectric Infrared Sensors



## Temperature Compensation Single Type Pyroelectric Infrared Sensor IRA-E420 Series

Single type pyroelectric infrared sensors IRA-E420 series have a temperature compensation element. They are suitable for flame detection and gas detection.

### ■ Features

1. High stability against abrupt ambient temperature changes
2. High immunity to external noise (Vibration, RFI etc.)
3. Custom design is available with varying optical filter.

### ■ Applications

Part Number	Optical Filter	Applications
IRA-E420S1	Silicon	1-15μm infrared detection
IRA-E420QW1	4.3μm band-pass	Flame detection
IRA-E420SW1	4.45μm band-pass	Flame detection

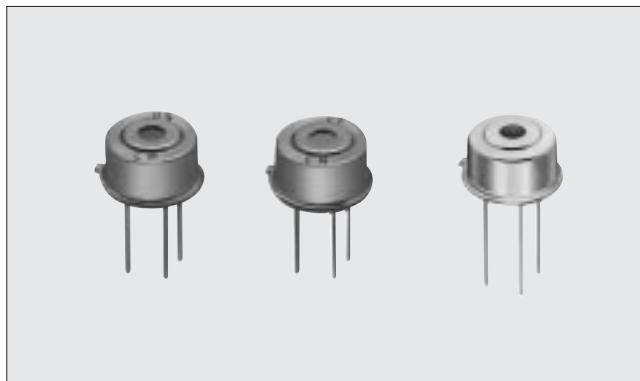

4

### ■ Dimensions & Circuit Diagrams (IRA-E420S1, IRA-E420QW1)

### (IRA-E420SW1)

<p>*Specified on the bottom of stem General Tolerance : ±0.2 (in mm)</p>	<p>*Specified on the bottom of stem General Tolerance : ±0.2 (in mm)</p>
<p>Pyroelectric element</p>	<p>Pyroelectric element</p>

■ Rating (25°C)

Part Number	IRA-E420S1	IRA-E420QW1	IRA-E420SW1
Responsivity (500K, 1Hz, 1Hz)	3.4mV <sub>p-p</sub> (Typ.)	1.3mV <sub>p-p</sub> (Typ.)*	0.45mV <sub>p-p</sub> (Typ.)
Field of View	$\theta_1=\theta_2=17^\circ$		$\theta_1=\theta_2=50^\circ$
Optical Filter	Silicon	4.3μm band-pass	4.45μm band-pass
Electrode	$\varnothing 1.6\text{mm}$		$\varnothing 1.8\text{mm}$
Supply Voltage	3 to 15V		
Operating Temperature	-25 to 70°C	-25 to 55°C	-25 to 70°C
Storage Temperature	-30 to 100°C		

\* 700K, 5Hz, 1Hz



## Pyroelectric Infrared Sensor IRA Series Characteristics Data

### ■ Spectral Response of Window Materials

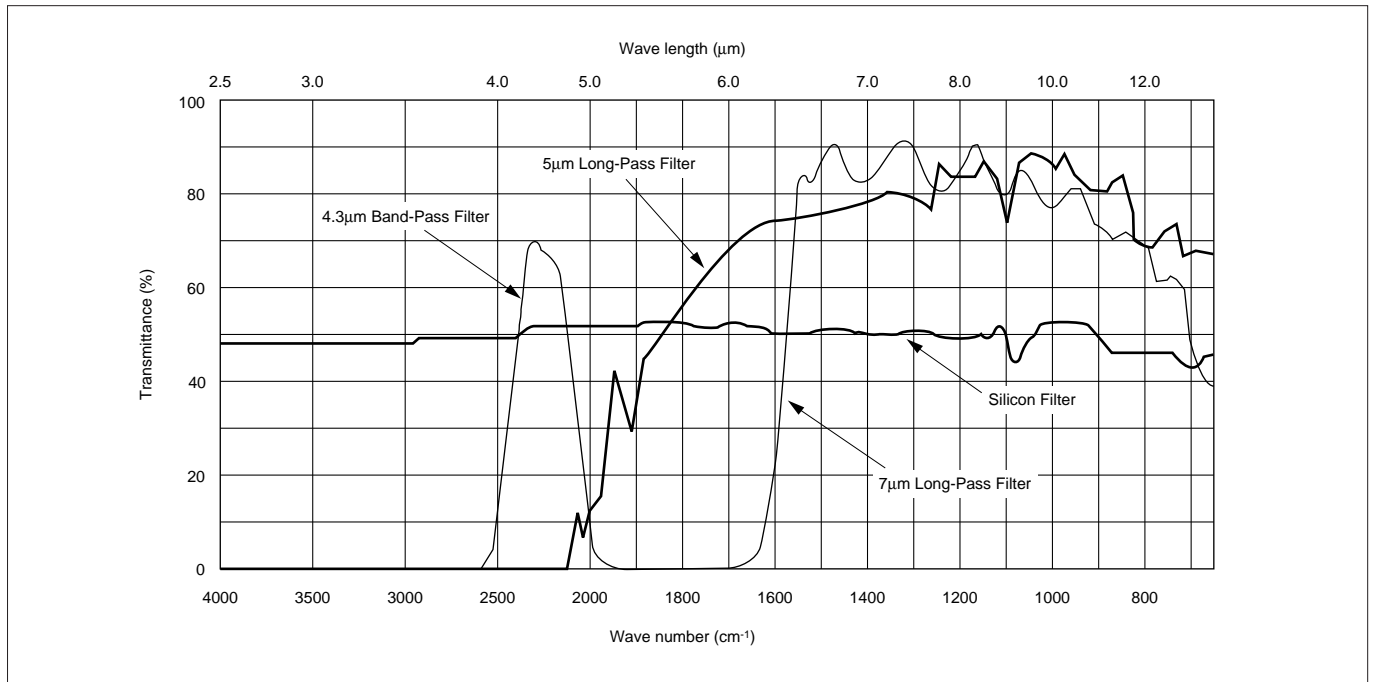

4

### ■ Frequency Characteristics

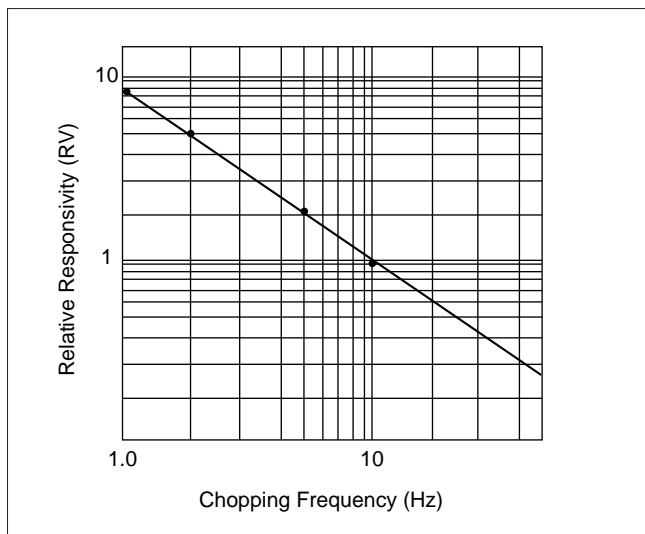

## Pyroelectric Infrared Sensor IRA Series Characteristics Data

### ■ Test Method of Sensitivity

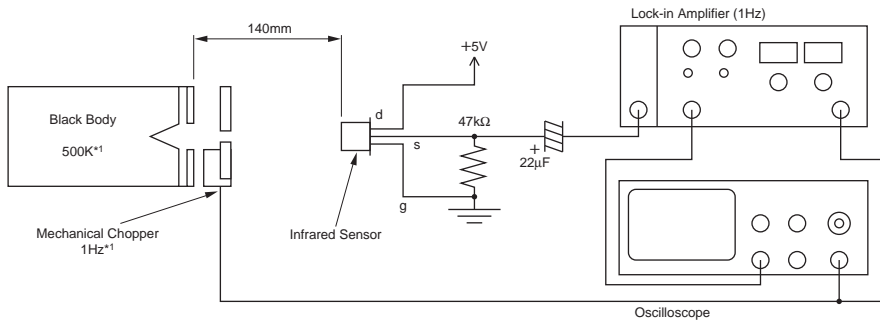

	Black Body	Mechanical Chopper
*1 IRA-E420QW1	700K	5Hz
IRA-E420SW1	400K	2.5Hz
IRA-E700/E900 Series	500K	1Hz

4

### ■ Typical Application Circuit (Human Detection)

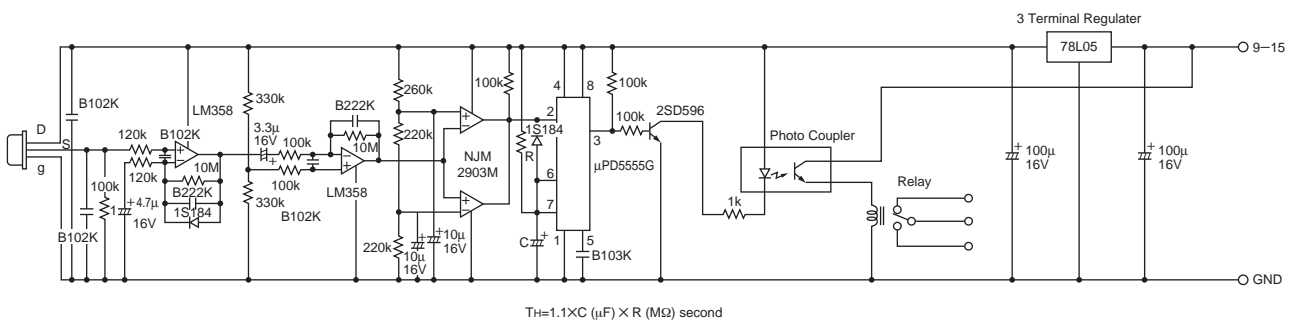

## Pyroelectric Infrared Sensor IRA Series Characteristics Data

### ■ Reliability Test

IRA-E700 series, IRA-E900 series

Item	Test Conditions	Criteria
High Temperature	100°C for 500 hrs.	After test completion, leave for three hours in normal humidity temperature conditions, and then measure. 1. External appearance: No significant damage 2. Sensitivity: Tolerance within 20% deviation from original value 3. Noise: Maximum tolerance +100mV of original value
Low Temperature	-40°C for 500 hrs.	
Humidity	60°C, 95% RH for 500 hrs.	
Heat Cycle	20 times of following cycle. -25°C, 30 min. ⇄ Room temp., 30 min. ↓ ↑ Room temp., 30 min. ⇄ 55°C, 30 min.	
Vibration	Apply vibration of amplitude of 1.5mm with 10 to 55Hz band to each of 3 perpendicular directions for 60 min.	
Shock	Apply shock of 100G sinewave by standard shock tester to each of 3 perpendicular directions.	
Soldering Heat	Immerse up to 3.0mm from can case in solder bath of 260±5°C for 10±1 s.	
Hermetic Sealing	Conform to MIL-STD-202F chapter 112D, condition D. Immerse in fluorocarbon bath (FC-40) of 125±5°C for 20 s.	

IRA-E420 series

Item	Test Conditions	Criteria
High Temperature	100°C for 500 hrs.	After test completion, leave for three hours in normal humidity temperature conditions, and then measure. 1. External appearance: No significant damage 2. Sensitivity: Tolerance within 20% deviation from original value 3. Noise: Maximum tolerance +100mV of original value
Low Temperature	-30°C for 500 hrs.	
Humidity	60°C, 95% RH for 500 hrs.	
Heat Cycle	20 times of following cycle. -25°C, 30 min. ⇄ Room temp., 30 min. ↓ ↑ Room temp., 30 min. ⇄ 55°C, 30 min.	
Vibration	Apply vibration of amplitude of 1.5mm with 10 to 55Hz band to each of 3 perpendicular directions for 60 min.	
Shock	Apply shock of 100G sinewave by standard shock tester to each of 3 perpendicular directions.	
Soldering Heat	Immerse up to 3.0mm from can case in solder bath of 260±5°C for 10±1 s.	
Hermetic Sealing	Conform to MIL-STD-202F chapter 112D, condition D. Immerse in fluorocarbon bath (FC-40) of 125±5°C for 20 s.	

# Pyroelectric Infrared Sensors/Fresnel Lens



PPGI0601

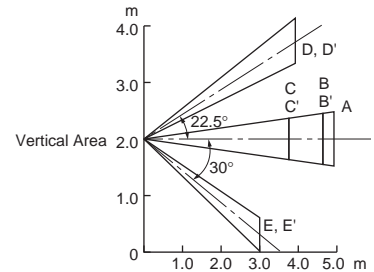
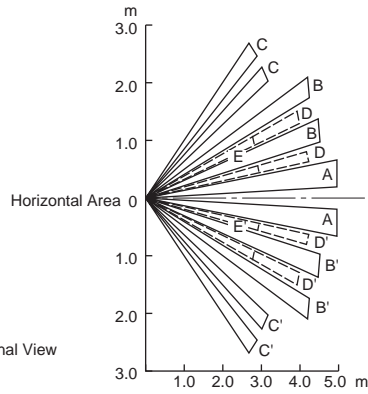
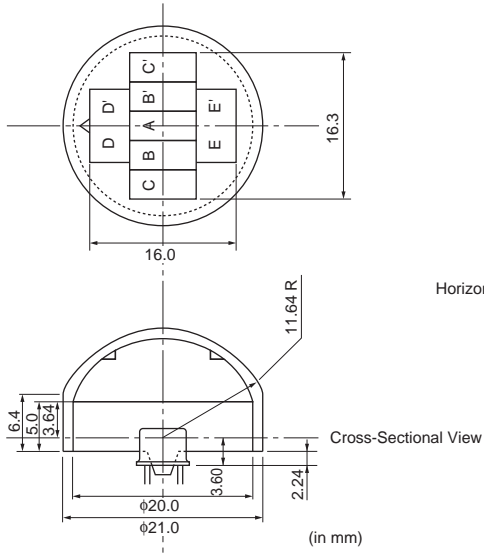

4

PPGI0902

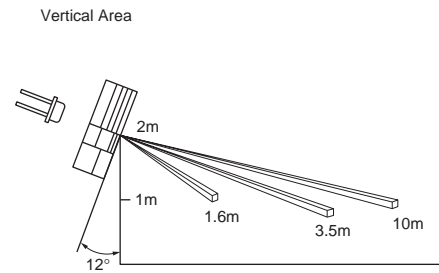
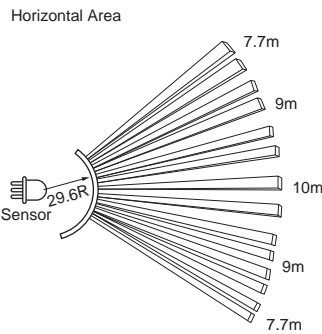
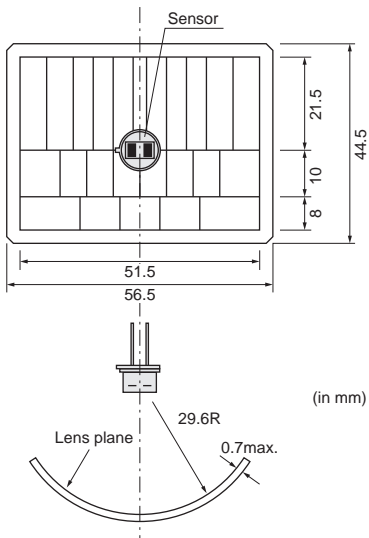

# Pyroelectric Infrared Sensors/Fresnel Lens



PPGI0626

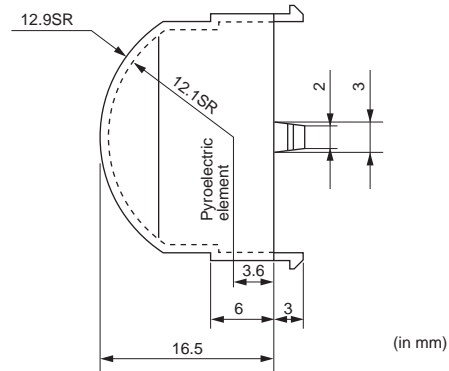
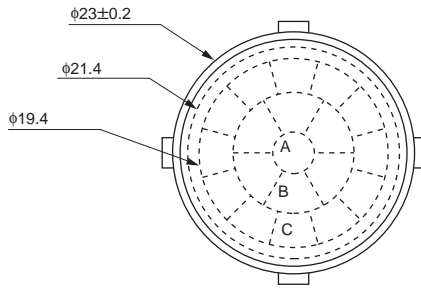

## Detection area on the floor

B : 60° pitch  
C : 30° pitch

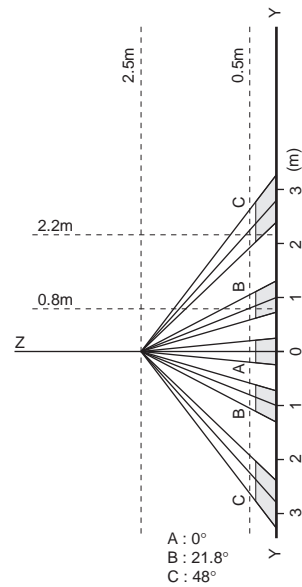
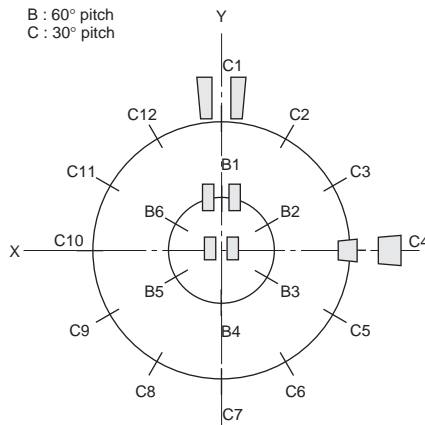

IML-0635

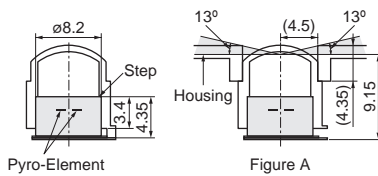
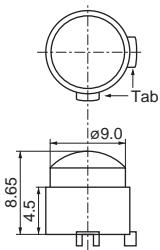

- 1) Insert a sensor into Fresnel lens like each tab is overlapped. (In case there are two tabs on Fresnel lens, the field of view is determined by your choice (TabA or B on Fresnel lens). Please see following page(s) for more details to see which characteristic of field of view is preferable for your application.)
- 2) Push the sensor into Fresnel lens until the top face of sensor reaches to the stopper inside Fresnel lens.
- 3) Please prepare a housing yourself that is put onto Fresnel lens as shown in Figure A. The hatching area shown in Figure A, must be obscured by the housing in order to prevent mis-detection. Unless otherwise unexpected infrared ray comes through the hatching area.

(in mm)  
General tolerance :  $\pm 0.2$

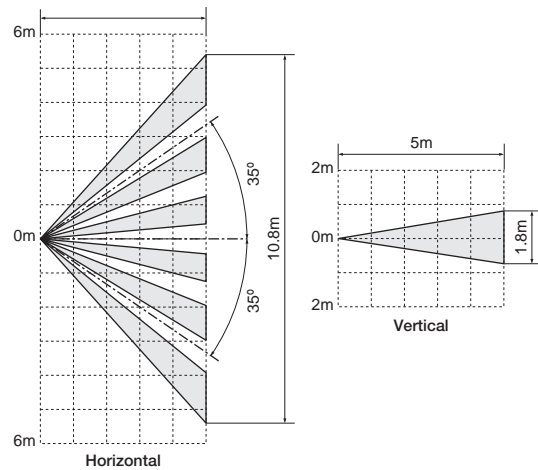

\*Assembled with Murata sensor IRA-700 series

# Pyroelectric Infrared Sensors/Fresnel Lens



## IML-0636

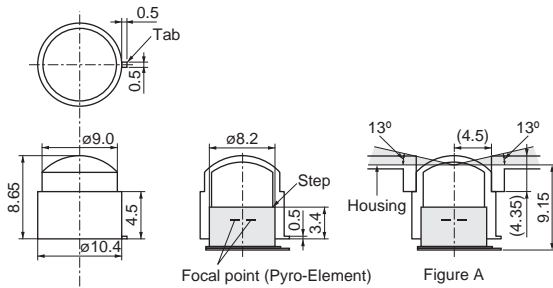

- 1) Insert a sensor into Fresnel lens like each tab is overlapped. (In case there are two tabs on Fresnel lens, the field of view is determined by your choice (TabA or B on Fresnel lens). Please see following page(s) for more details to see which characteristic of field of view is preferable for your application.)
- 2) Push the sensor into Fresnel lens until the top face of sensor reaches to the stopper inside Fresnel lens.
- 3) Please prepare a housing yourself that is put onto Fresnel lens as shown in FigureA. The hatching area shown in Figure A, must be obscured by the housing in order to prevent mis-detection. Unless otherwise unexpected infrared ray comes though the hatching area.

(in mm)  
General tolerance : ±0.2

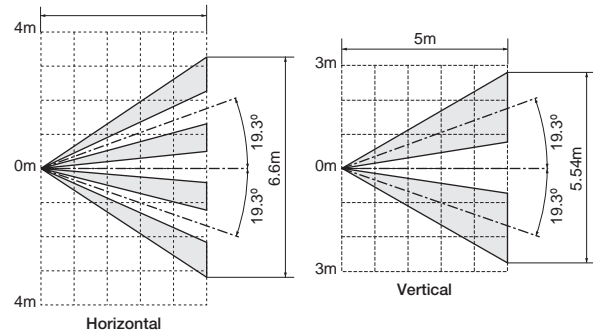

\*Assembled with Murata sensor IRA-700 series

## IML-0637

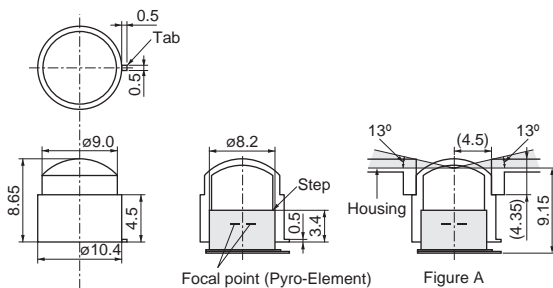

- 1) Insert a sensor into Fresnel lens like each tab is overlapped. (In case there are two tabs on Fresnel lens, the field of view is determined by your choice (TabA or B on Fresnel lens). Please see following page(s) for more details to see which characteristic of field of view is preferable for your application.)
- 2) Push the sensor into Fresnel lens until the top face of sensor reaches to the stopper inside Fresnel lens.
- 3) Please prepare a housing yourself that is put onto Fresnel lens as shown in FigureA. The hatching area shown in Figure A, must be obscured by the housing in order to prevent mis-detection. Unless otherwise unexpected infrared ray comes though the hatching area.

(in mm)  
General tolerance : ±0.2

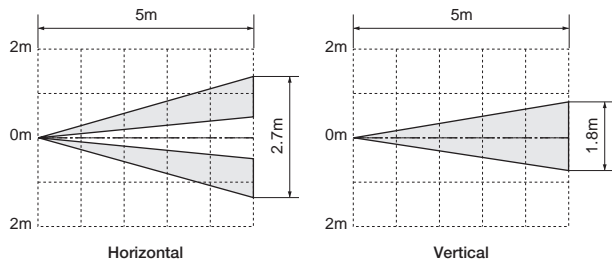

\*Assembled with Murata sensor IRA-700 series

## IML-0638

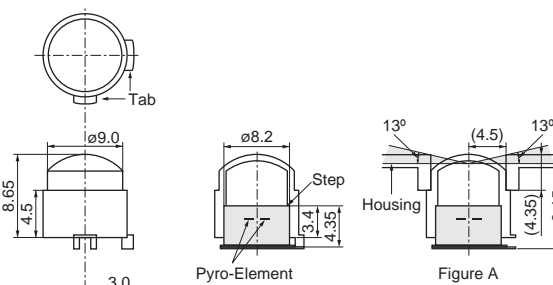

- 1) Insert a sensor into Fresnel lens like each tab is overlapped. (In case there are two tabs on Fresnel lens, the field of view is determined by your choice (TabA or B on Fresnel lens). Please see following page(s) for more details to see which characteristic of field of view is preferable for your application.)
- 2) Push the sensor into Fresnel lens until the top face of sensor reaches to the stopper inside Fresnel lens.
- 3) Please prepare a housing yourself that is put onto Fresnel lens as shown in FigureA. The hatching area shown in Figure A, must be obscured by the housing in order to prevent mis-detection. Unless otherwise unexpected infrared ray comes though the hatching area.

(in mm)  
General tolerance : ±0.2

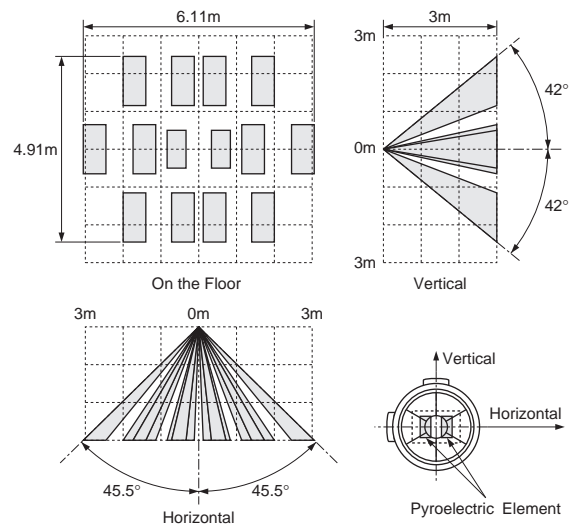

Assembled with Murata sensor IRA-700 Series.

Fresnel lens are available upon request.

4

## Notice

### ■ Notice

#### 1. Caution (Design)

- (1) Please make sure that your product has been evaluated and confirmed against your specifications when our product is mounted to your product.
- (2) Be sure to provide an appropriate fail-safe function on your product to prevent a second damage that may be caused by the abnormal function or the failure of our product.
- (3) In case of outdoor use, suitable optical filter and water and humidity proof structure should be applied.
- (4) To prevent failure or malfunction, please use a stabilized power supply.
- (5) Please avoid using the sensor in the following conditions because it may cause failure or malfunction.
  - (a) in such a fluid as water, alcohol etc. corrosive gas (SO<sub>2</sub>, Cl<sub>2</sub>, NO<sub>x</sub> etc.) or sea breeze
  - (b) in high humidity
  - (c) in a place exposed directly to sunlight or headlights of automobile
  - (d) in a place exposed to rapid ambient temperature change
  - (e) in a place exposed directly to an air-conditioner or heat vent
  - (f) strong vibrations
  - (g) in a place exposed to strong electromagnetic field
  - (h) in such a place where infrared ray is shaded
  - (i) in any other place similar to the above (a) through (h)

#### 2. Caution (Mounting)

- (1) Soldering
  - (a) Hand soldering should be applied.
  - (b) Soldering should be done quickly as following.

Temperature of soldering iron : 350°C	
Distance from can case	Period of time
1 to 3mm	Within 3 seconds per point
Over 3mm	Within 10 seconds per point

- (c) Soldering flux should be rosin flux and not contain more than 0.2wt% chlorine.  
Soldering flux should be removed after soldering.
- (2) Cleaning  
Soldering flux should be removed after soldering.  
Soldering flux may cause malfunction or degradation of character unless sufficiently cleaned.

#### 3. Caution (Handling and Storage)

- (1) The optical filter of the sensor should not be scratched or soiled.
- (2) Strong shock should be avoided.
- (3) Electrostatics and strong electromagnetic field should be avoided.
- (4) The sensor should be kept on conductive sponge.
- (5) High temperature, high humidity, fluid such as water or alcohol etc., corrosive gas (SO<sub>2</sub>, Cl<sub>2</sub>, NO<sub>x</sub> etc.) and sea breeze should be avoided.

**⚠ Note:**

1. Export Control

⟨For customers outside Japan⟩

Murata products should not be used or sold for use in the development, production, stockpiling or utilization of any conventional weapons or mass-destructive weapons (nuclear weapons, chemical or biological weapons, or missiles), or any other weapons.

⟨For customers in Japan⟩

For products which are controlled items subject to the "Foreign Exchange and Foreign Trade Law" of Japan, the export license specified by the law is required for export.

2. Please contact our sales representatives or product engineers before using the products in this catalog for the applications listed below, which require especially high reliability for the prevention of defects which might directly damage to a third party's life, body or property, or when one of our products is intended for use in applications other than those specified in this catalog.

- |                             |   |
|-----------------------------|---|
| ① Aircraft equipment        | ② Aerospace equipment   |
| ③ Undersea equipment        | ④ Power plant equipment   |
| ⑤ Medical equipment         | ⑥ Transportation equipment (vehicles, trains, ships, etc.)  |
| ⑦ Traffic signal equipment  | ⑧ Disaster prevention / crime prevention equipment  |
| ⑨ Data-processing equipment | ⑩ Application of similar complexity and/or reliability requirements to the applications listed in the above |

3. Product specifications in this catalog are as of August 2005. They are subject to change or our products in it may be discontinued without advance notice. Please check with our sales representatives or product engineers before ordering. If there are any questions, please contact our sales representatives or product engineers.

4. Please read rating and ⚠CAUTION (for storage, operating, rating, soldering, mounting and handling) in this catalog to prevent smoking and/or burning, etc.

5. This catalog has only typical specifications because there is no space for detailed specifications. Therefore, please approve our product specifications or transact the approval sheet for product specifications before ordering.

6. Please note that unless otherwise specified, we shall assume no responsibility whatsoever for any conflict or dispute that may occur in connection with the effect of our and/or a third party's intellectual property rights and other related rights in consideration of your use of our products and/or information described or contained in our catalogs. In this connection, no representation shall be made to the effect that any third parties are authorized to use the rights mentioned above under licenses without our consent.

7. No ozone depleting substances (ODS) under the Montreal Protocol are used in our manufacturing process.



## X-ON Electronics

Largest Supplier of Electrical and Electronic Components

*Click to view similar products for [Board Mount Motion & Position Sensors](#) category:*

*Click to view products by [Murata](#) manufacturer:*

Other Similar products are found below :

[SV03A103AEA01B00](#) [601HE0000B01](#) [6SS4](#) [IRA-S510ST01](#) [KMA221J](#) [XL-10043](#) [F02008062](#) [M10-JK8002C](#) [UM7-LT ORIENTATION SENSOR](#) [UM7 ORIENTATION SENSOR](#) [AMN33111J](#) [MTS-360-1A-C0000-ERA360-05E](#) [F01551006](#) [AMN11111](#) [AMN24112](#) [AMN31111](#) [AMN31112](#) [AMN34112](#) [AMN34111](#) [AMN23111](#) [SV03A103AEA01R00](#) [EKMC1693113](#) [EKMB1303111K](#) [EKMB1293112](#) [PST360-11302-1P-C0000-ERA360-24E-F100](#) [AMBA340215](#) [AMBA210205](#) [AMA115915](#) [A1324LLHLTT](#) [MLX91204KDC-ABA-001-SP](#) [EKMC1605111](#) [MLX90380LDC-BAB-120-SP](#) [02183000-000](#) [3382H-1-104](#) [EKMB1104111](#) [EKMB1204111](#) [EKMB1305111K](#) [EKMC1604112](#) [EKMB1305112K](#) [EKMB1205111](#) [EKMB1205112](#) [AMBA240202](#) [EKMB1304113K](#) [EKMB1105111](#) [EKMB1105112](#) [EKMC1693112](#) [EKMC1605112](#) [MLX90316EDC-BCG-000-SP](#) [EKMB1305113K](#) [AMBA345912](#)