

# 16kV ESD Protected, +125°C, 3.0V to 5.5V, TDFN Packaged, Low Power RS-485/RS-422 Transmitter

## ISL3298EMRTEP

The Intersil ISL3298EMRTEP is a ±16.5kV HBM ESD Protected (7kV IEC61000 contact), 3.0V to 5.5V powered, single transmitter for balanced communication using the RS-485 and RS-422 standards. This driver has very low bus currents (±40mA), so it presents less than a “1/8 unit load” to the RS-485 bus. This allows more than 256 transmitters on the network without violating the RS-485 specification’s 32 unit load maximum, and without using repeaters.

Hot Plug circuitry ensures that the Tx outputs remain in a high impedance state while the power supply stabilizes.

The driver on the ISL3298EMRTEP is not limited, so it can achieve a 16Mbps data rate and is offered in the -55°C to +125°C temperature range.

This devices also feature a logic supply pin (V<sub>L</sub>) that sets the switching points of the DE and DI inputs to be compatible with a lower supply voltage in mixed voltage systems.

For a companion single RS-485 receiver in micro packages, please see the ISL3282EMRTEP data sheet.

## Applications

- Clock Distribution
- High Node Count Systems
- Space Constrained Systems
- Security Camera Networks
- Building Environmental Control/Lighting Systems
- Industrial/Process Control Networks

## Features

- Specifications per DLA VID V62/10602
- Full Mil-Temp Electrical Performance from -55°C to +125°C
- Controlled Baseline with One Wafer Fabrication Site and One Assembly/Test Site
- Full Homogeneous Lot Processing in Wafer Fab
- No Combination of Wafer Fabrication Lots in Assembly
- Full Traceability Through Assembly and Test by Date/Trace Code Assignment
- Enhanced Process Change Notification
- Enhanced Obsolescence Management
- Eliminates Need for Up-Screening a COTS Component
- High ESD Protection on RS-485 Outputs . . . . ±16.5kV HBM
  - IEC61000-4-2 Contact Test Method. . . . . ±7kV
  - Class 3 ESD Level on all Other Pins. . . . . >8kV HBM
- Specified for +125°C Operation (V<sub>CC</sub> ≤ 3.6V Only)
- Logic Supply Pin (V<sub>L</sub>) Eases Operation in Mixed Supply Systems
- Hot Plug - Tx Output Remains Three-state During Power-up
- Low Tx Leakage Allows >256 Devices on the Bus
- High Data Rates . . . . . up to 16Mbps
- Low Quiescent Supply Current . . . . . 150µA (Max)
  - Very Low Shutdown Supply Current. . . . . 1µA (Max)
- -7V to +12V Common Mode Output Voltage Range (V<sub>CC</sub> ≤ 3.6V Only)
- Current Limiting and Thermal Shutdown for Driver Overload Protection (V<sub>CC</sub> ≤ 3.6V Only)
- Tri-statable Tx Output
- 5V Tolerant Logic Input When V<sub>CC</sub> ≤ 5V

TABLE 1. SUMMARY OF FEATURES

PART NUMBER	FUNCTION	DATA RATE (Mbps)	SLEW-RATE LIMITED?	HOT PLUG?	V <sub>L</sub> PIN?	TX ENABLE?	MAXIMUM QUIESCENT I <sub>CC</sub> (µA)	LOW POWER SHUTDOWN?	PIN COUNT
ISL3298EMRTEP	1 Tx	16	NO	YES	YES	YES	150	YES	8-TDFN

# ISL3298EMRTEP

## Truth Table

TRANSMITTING			
INPUTS		OUTPUTS	
DE	DI	Z	Y
1	1	0	1
1	0	1	0
0	X	High-Z *	High-Z *

NOTE: \*Shutdown Mode

## Pin Configuration

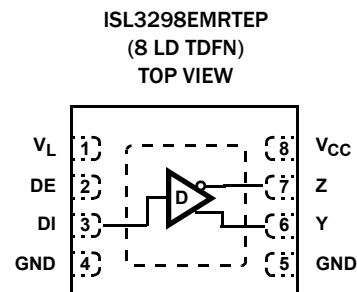

## Pin Descriptions

PIN NUMBER	PIN SYMBOL	FUNCTION
1	V <sub>L</sub>	Logic-Level supply which sets the V <sub>IL</sub> /V <sub>IH</sub> levels for the DI and DE pins. Power-up this supply after V <sub>CC</sub> , and keep V <sub>L</sub> ≤ V <sub>CC</sub> .
2	DE	Driver output enable. The driver outputs, Y and Z, are enabled by bringing DE high, and are high impedance when DE is low. If the driver enable function isn't needed, connect DE to V <sub>CC</sub> (or V <sub>L</sub> ) through a 1kΩ to 3kΩ resistor.
3	DI	Driver input. A low on DI forces output Y low and output Z high. Similarly, a high on DI forces output Y high and output Z low.
4, 5	GND	Ground connection. This is also the potential of the TDFN thermal pad.
6	Y	±15kV HBM, ±7kV IEC61000 (contact method) ESD Protected RS-485/422 level, noninverting transmitter output.
7	Z	±15kV HBM, ±7kV IEC61000 (contact method) ESD Protected RS-485/422 level, inverting transmitter output.
8	V <sub>CC</sub>	System power supply input (3.0V to 5.5V). On devices with a V <sub>L</sub> pin, power-up V <sub>CC</sub> first.

## Ordering Information

PART NUMBER (Note)	VENDOR ITEM DRAWING	PART MARKING	TEMP. RANGE (°C)	PACKAGE (Tape and Reel)
ISL3298EMRTEP-T	V62/10602-01XB	298	-55 to +125	8 Ld TDFN
ISL3298EMRTEP-TK	V62/10602-01XB	298	-55 to +125	8 Ld TDFN

NOTE: Please refer to [IB347](#) for details on reel specifications.

## Typical Operating Circuit

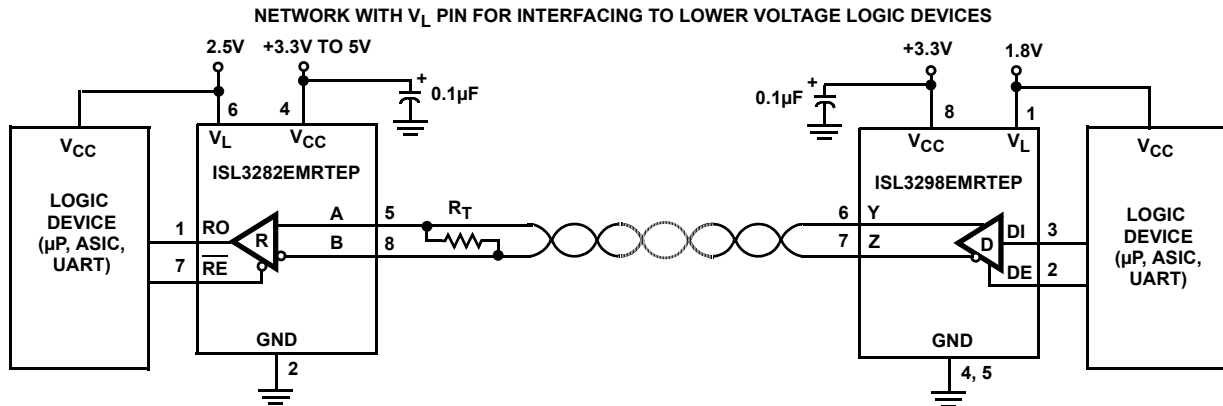

## Test Circuits and Waveforms

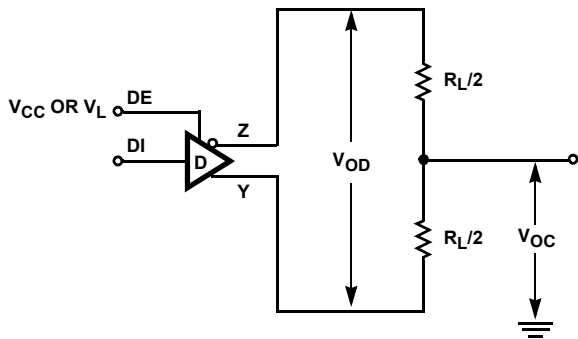

FIGURE 1A.  $V_{OD}$  AND  $V_{OC}$

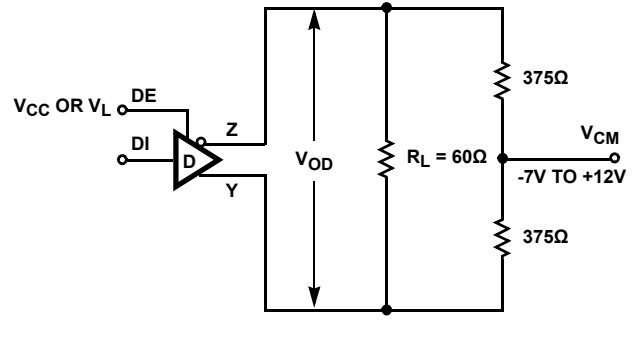

FIGURE 1B.  $V_{OD}$  WITH COMMON MODE LOAD

FIGURE 1. DC DRIVER TEST CIRCUITS

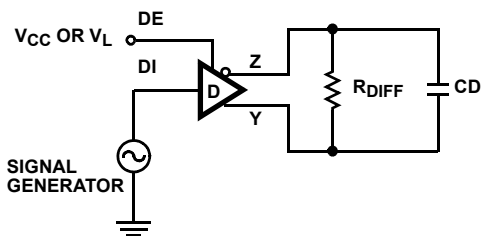
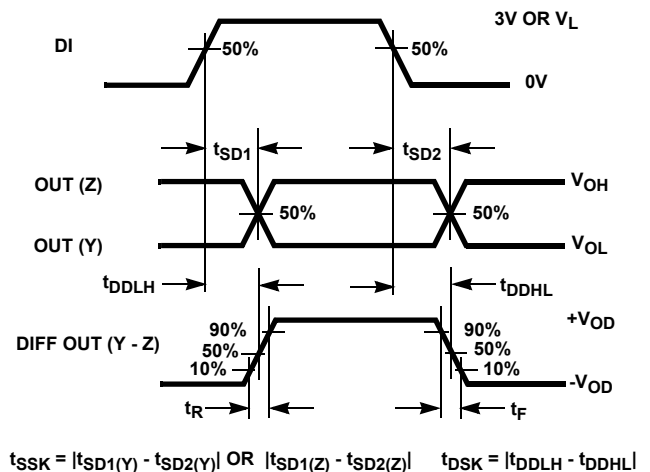

FIGURE 2A. TEST CIRCUIT



$$t_{SSK} = |t_{SD1(Y)} - t_{SD2(Y)}| \text{ OR } |t_{SD1(Z)} - t_{SD2(Z)}| \quad t_{DSK} = |t_{DDLH} - t_{DDLH}|$$

FIGURE 2B. MEASUREMENT POINTS

FIGURE 2. DRIVER PROPAGATION DELAY AND DIFFERENTIAL TRANSITION TIMES

## Test Circuits and Waveforms (Continued)

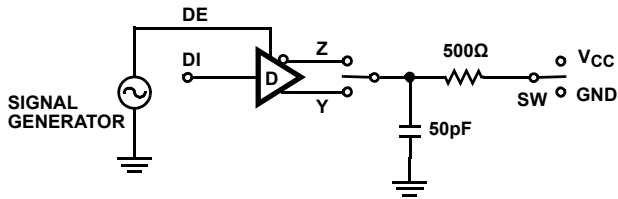

PARAMETER	OUTPUT	DI	SW
$t_{HZ}$	Y/Z	1/0	GND
$t_{LZ}$	Y/Z	0/1	$V_{CC}$
$t_{ZH}$	Y/Z	1/0	GND
$t_{ZL}$	Y/Z	0/1	$V_{CC}$

FIGURE 3A. TEST CIRCUIT

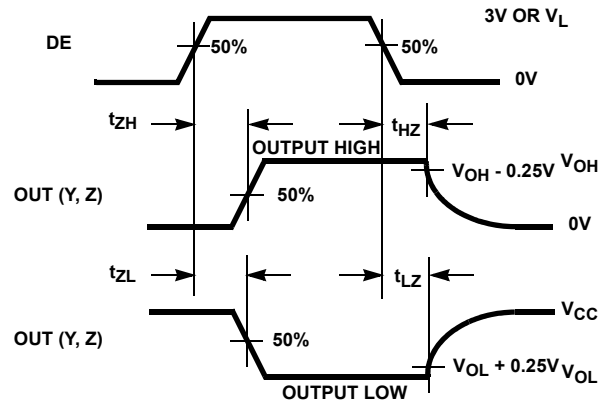

FIGURE 3B. MEASUREMENT POINTS

FIGURE 3. DRIVER ENABLE AND DISABLE TIMES

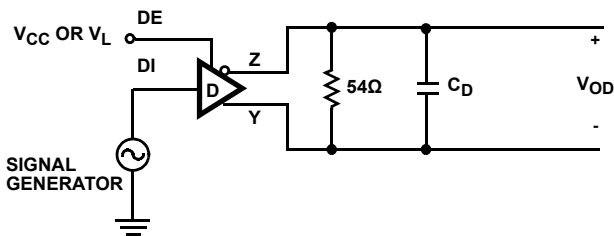

FIGURE 4A. TEST CIRCUIT

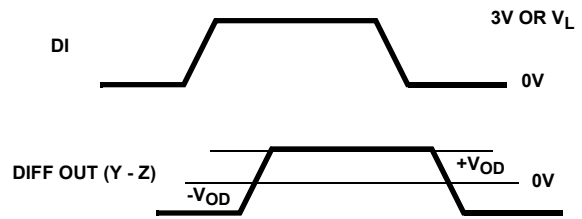

FIGURE 4B. MEASUREMENT POINTS

FIGURE 4. DRIVER DATA RATE

## Applications Information

RS-485 and RS-422 are differential (balanced) data transmission standards for use in long haul or noisy environments. RS-422 is a subset of RS-485, so RS-485 transmitters and receivers are also RS-422 compliant. RS-422 is a point-to-multipoint (multidrop) standard, which allows only one driver and up to 10 (assuming one unit load devices) receivers on each bus. RS-485 is a true multipoint standard, which allows up to 32 one unit load devices (any combination of drivers and receivers) on each bus. To allow for multipoint operation, the RS-485 specification requires that drivers must handle bus contention without sustaining any damage.

Another important advantage of RS-485 is the extended common mode range (CMR), which specifies that the driver outputs and receiver inputs withstand signals that range from +12V to -7V. RS-422 and RS-485 are intended for runs as long as 4000', so the wide CMR is necessary to handle ground potential differences, as well as voltages induced in the cable by external fields.

### Driver Features

This RS-485/RS-422 driver is a differential output device that delivers at least 1.5V across a 54Ω load (RS-485), and at least 2V across a 100Ω load (RS-422). The drivers feature low propagation delay skew to maximize bit width, and to minimize EMI.

The driver is tri-statable via the active high DE input. If the Tx enable function isn't needed, tie DE to V<sub>CC</sub> (or V<sub>L</sub>) through a 1kΩ to 3kΩ resistor.

The ISL3298EMRTEP's output transition times allow data rates of at least 16Mbps.

### Wide Supply Range

The ISL3298EMRTEP is optimized for 3.3V operation, but can be operated with supply voltages as high as 5.5V. This device meets the RS-422 and RS-485 specifications for supply voltages less than 4V, and is RS-422 and RS-485 compatible for supplies greater than 4V. Operation at +125°C requires V<sub>CC</sub> ≤ 3.6V, while 5V operation requires adding output current limiting resistors (as described in the "Driver Overload Protection" on page 6) if output short circuits (e.g., from bus contention) are a possibility.

### 5.5V Tolerant Logic Pins

Logic input pins (DI, DE) contain no ESD nor parasitic diodes to V<sub>CC</sub> (nor to V<sub>L</sub>), so they withstand input voltages exceeding 5.5V regardless of the V<sub>CC</sub> and V<sub>L</sub> voltages (see Figure 5).

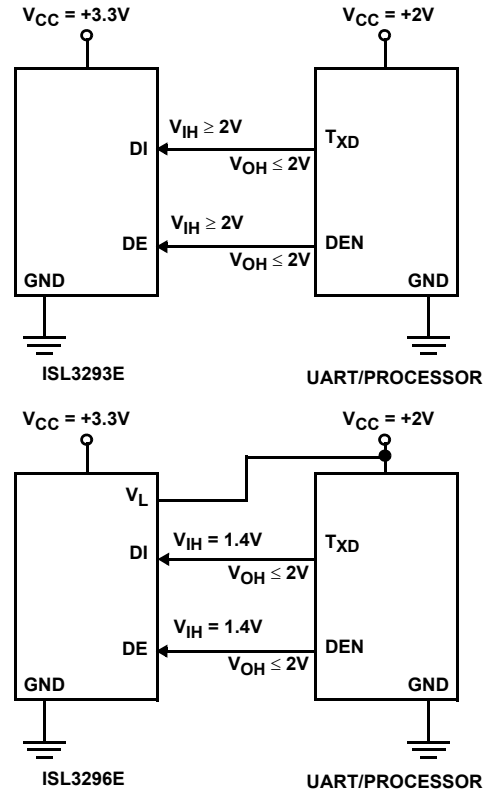

FIGURE 5. USING V<sub>L</sub> PIN TO ADJUST LOGIC LEVELS

### Logic Supply (V<sub>L</sub> Pin)

Note: Power-up V<sub>CC</sub> before powering up the V<sub>L</sub> supply.

The ISL3298EMRTEP includes a V<sub>L</sub> pin that powers the logic inputs (DI and DE). These pins interface with "logic" devices such as UARTs, ASICs, and μcontrollers, and today most of these devices use power supplies significantly lower than 3.3V. Thus, the logic device's low V<sub>OH</sub> might not exceed the V<sub>IH</sub> of a 3.3V or 5V powered DI or DE input. Connecting the V<sub>L</sub> pin to the power supply of the logic device (as shown in Figure 5) reduces the DI and DE input switching points to values compatible with the logic device's output levels. Tailoring the logic pin input switching points and output levels to the supply voltage of the UART, ASIC, or μcontroller eliminates the need for a level shifter/translator between the two ICs.

V<sub>L</sub> can be anywhere from V<sub>CC</sub> down to 1.35V, but the input switching points may not provide enough noise margin, and 16Mbps data rates may not be achievable, when V<sub>L</sub> < 1.5V. The E.C. table in the SMD indicates typical V<sub>IH</sub> and V<sub>IL</sub> values for various V<sub>L</sub> settings so the user can ascertain whether or not a particular V<sub>L</sub> voltage meets his/her needs.

The V<sub>L</sub> supply current (I<sub>L</sub>) is typically much less than 20μA, as shown in Figure 9, when DE and DI are above/below V<sub>IH</sub>/V<sub>IL</sub>.

## Hot Plug Function

When a piece of equipment powers-up, there is a period of time where the processor or ASIC driving the RS-485 control line (DE) is unable to ensure that the RS-485 Tx outputs are kept disabled. If the equipment is connected to the bus, a driver activating prematurely during power up may crash the bus. To avoid this scenario, the ISL3298EMRTEP incorporates a “Hot Plug” function. During power-up, circuitry monitoring  $V_{CC}$  ensures that the Tx outputs remain disabled for a period of time, regardless of the state of DE. This gives the processor/ASIC a chance to stabilize and drive the RS-485 control lines to the proper states.

## ESD Protection

All pins on this device includes class 3 (8kV) Human Body Model (HBM) ESD protection structures, but the RS-485 pins (driver outputs) incorporate advanced structures allowing it to survive ESD events in excess of  $\pm 16.5\text{kV}$  HBM and  $\pm 7\text{kV}$  to the IEC61000 contact test method. The RS-485 pins are particularly vulnerable to ESD damage because they typically connect to an exposed port on the exterior of the finished product. Simply touching the port pins, or connecting a cable, can cause an ESD event that might destroy unprotected ICs. These new ESD structures protect the device whether or not it is powered up, and without degrading the RS-485 common mode range of -7V to +12V. This built-in ESD protection eliminates the need for board level protection structures (e.g., transient suppression diodes), and the associated, undesirable capacitive load they present.

## Data Rate, Cables, and Terminations

RS-485/RS-422 are intended for network lengths up to 4000', but the maximum system data rate decreases as the transmission length increases. Devices operating at 16Mbps are limited to lengths less than 100'.

Twisted pair is the cable of choice for RS-485/RS-422 networks. Twisted pair cables tend to pick up noise and other electromagnetically induced voltages as common mode signals, which are effectively rejected by the differential receivers in these ICs. Proper termination is imperative, to minimize reflections.

In point-to-point, or point-to-multipoint (single driver on bus) networks, the main cable should be terminated in its characteristic impedance (typically  $120\Omega$ ) at the end farthest from the driver. In multi-receiver applications, stubs connecting receivers to the main cable should be kept as short as possible. Multipoint (multi-driver) systems require that the main cable be terminated in its characteristic impedance at both ends. Stubs connecting a transmitter or receiver to the main cable should be kept as short as possible.

## Driver Overload Protection

As stated previously, the RS-485 specification requires that drivers survive worst case bus contentions undamaged. These drivers meet this requirement, for  $V_{CC} \leq 3.6\text{V}$ , via driver output short circuit current limits, and on-chip thermal shutdown circuitry.

The driver output stages incorporate short circuit current limiting circuitry which ensures that the output current never exceeds the RS-485 specification, for  $V_{CC} \leq 3.6\text{V}$ , even at the common mode voltage range extremes. Additionally, these devices utilize a foldback circuit which reduces the short circuit current, and thus the power dissipation, whenever the contending voltage exceeds either  $V_{CC}$  or GND.

In the event of a major short circuit condition, devices also include a thermal shutdown feature that disables the drivers whenever the die temperature becomes excessive. This eliminates the power dissipation, allowing the die to cool. The drivers automatically re-enable after the die temperature drops about  $+20^\circ\text{C}$ . If the contention persists, the thermal shutdown/re-enable cycle repeats until the fault is cleared.

At  $V_{CC} > 3.6\text{V}$ , the instantaneous short circuit current is high enough that output stage damage may occur during short circuit conditions to voltages outside of GND to  $V_{CC}$ , before the short circuit limiting and thermal shutdown activate. For  $V_{CC} = 5\text{V}$  operation, if output short circuits are a possibility (e.g., due to bus contention), it is recommended that a  $5\Omega$  resistor be inserted in series with each output. This resistor limits the instantaneous current below levels that can cause damage. The driver  $V_{OD}$  at  $V_{CC} = 5\text{V}$  is so large that this small added resistance has little impact.

## High Temperature Operation

Due to power dissipation and instantaneous output short circuit current levels at  $V_{CC} = 5\text{V}$ , these transmitters may not be operated at  $+125^\circ\text{C}$  with  $V_{CC} > 3.6\text{V}$ .

At  $V_{CC} = 3.6\text{V}$ , the device may be operated at  $+125^\circ\text{C}$ , while driving a 100', double terminated, CAT 5 cable at 16Mbps, without triggering the thermal SHDN circuit.

## Low Power Shutdown Mode

This BiCMOS transmitter uses a fraction of the power required by its bipolar counterparts and it also includes a shutdown feature that reduces the already low quiescent  $I_{CC}$  to a  $1\mu\text{A}$  trickle. This device enters shutdown whenever the driver disables (DE = GND).

## Typical Performance Curves $V_{CC} = V_L = 3.3V, T_A = +25^\circ C$ ; Unless Otherwise Specified

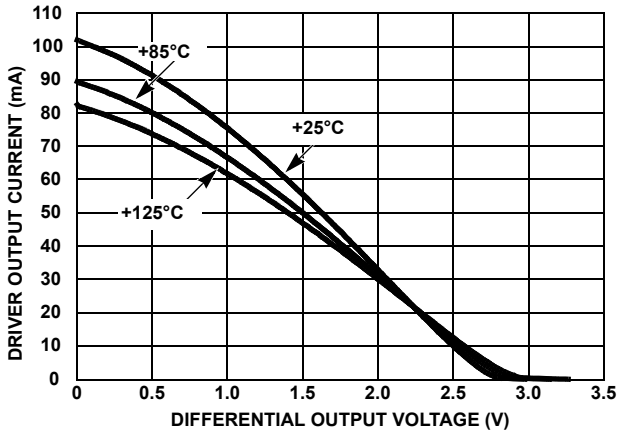

FIGURE 6. DRIVER OUTPUT CURRENT vs DIFFERENTIAL OUTPUT VOLTAGE

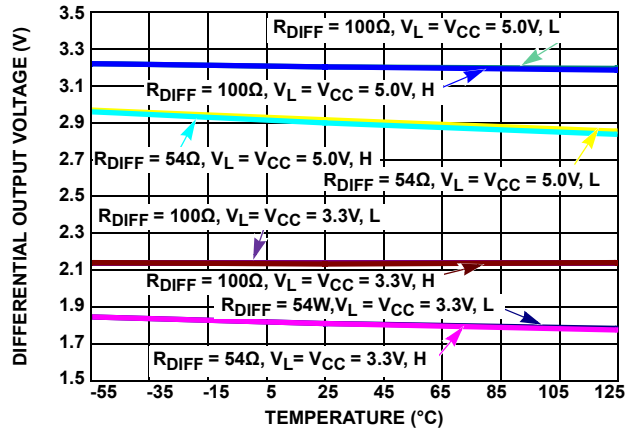

FIGURE 7. DRIVER DIFFERENTIAL OUTPUT VOLTAGE vs TEMPERATURE

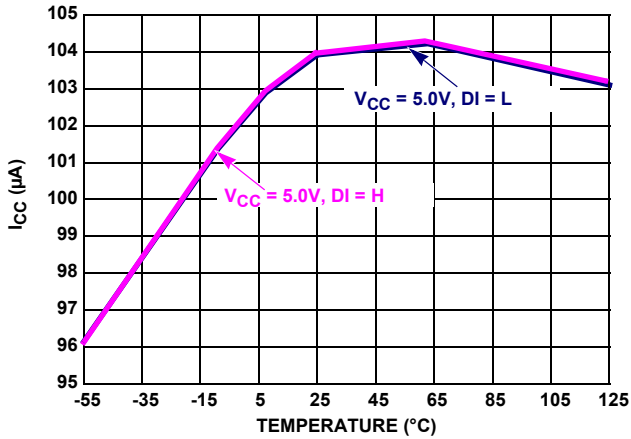

FIGURE 8. SUPPLY CURRENT vs TEMPERATURE

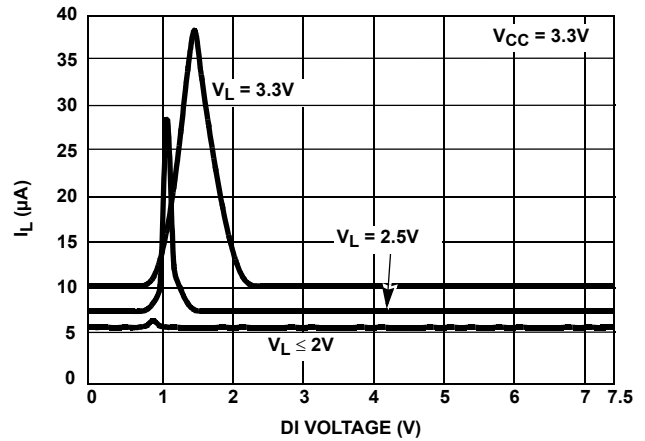

FIGURE 9.  $V_L$  SUPPLY CURRENT vs LOGIC PIN VOLTAGE

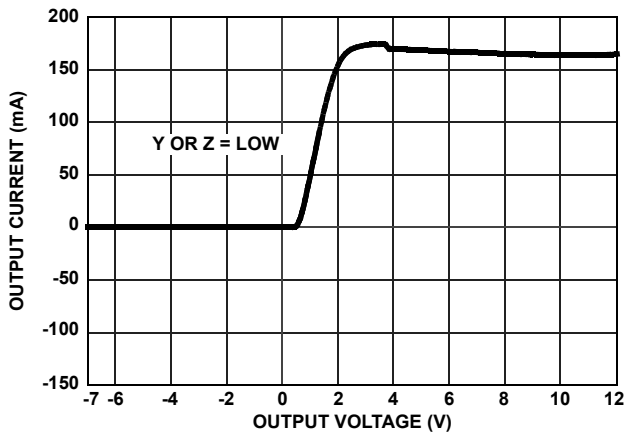

FIGURE 10. DRIVER OUTPUT CURRENT vs SHORT CIRCUIT VOLTAGE

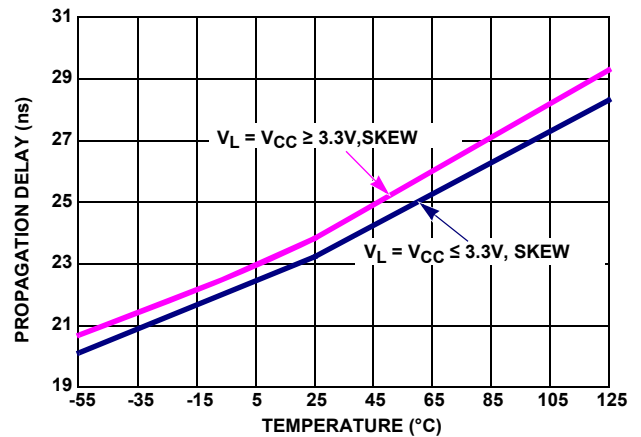

FIGURE 11. DRIVER DIFFERENTIAL PROPAGATION DELAY vs TEMPERATURE

## Typical Performance Curves $V_{CC} = V_L = 3.3V$ , $T_A = +25^\circ C$ ; Unless Otherwise Specified (Continued)

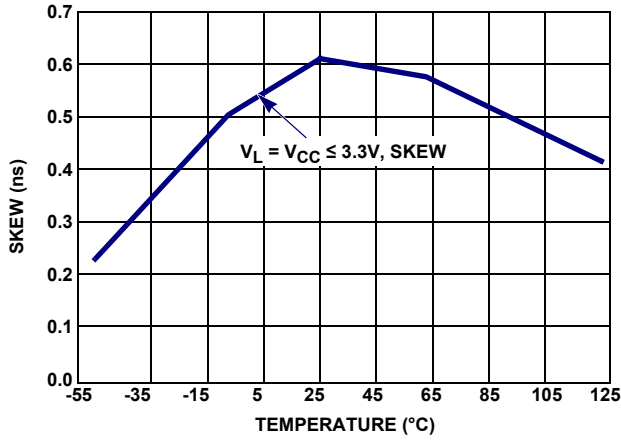

FIGURE 12. DRIVER DIFFERENTIAL SKEW vs TEMPERATURE

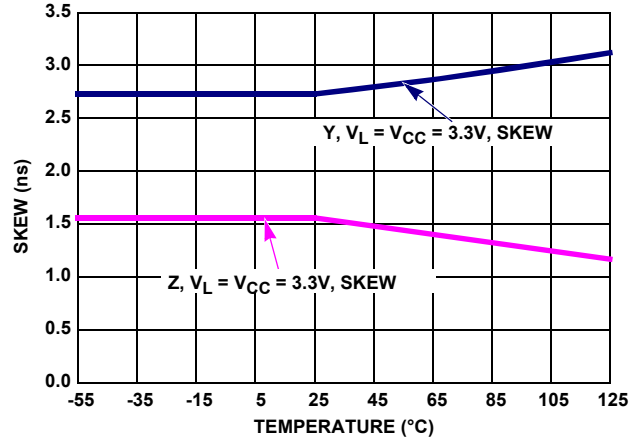

FIGURE 13. DRIVER SINGLE-ENDED SKEW vs TEMPERATURE

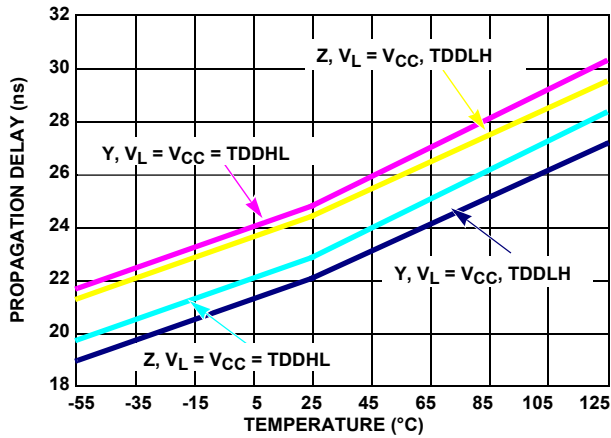

FIGURE 14. SINGLE-ENDED PROPAGATION DELAY vs TEMPERATURE

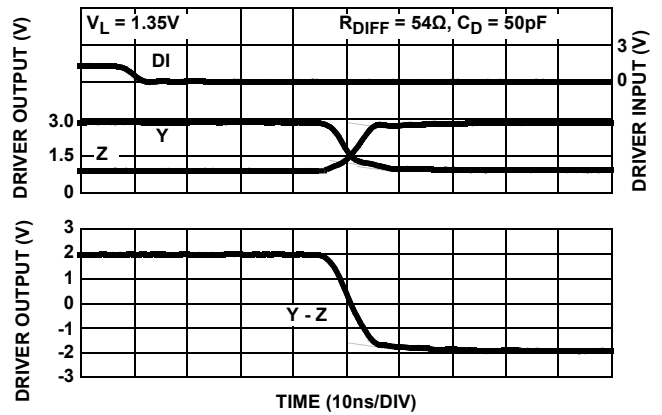

FIGURE 15. DRIVER WAVEFORMS, HIGH TO LOW

## Die Characteristics

### SUBSTRATE AND TDFN THERMAL PAD POTENTIAL (POWERED UP):

GND

### TRANSISTOR COUNT:

516

### PROCESS:

Si Gate BiCMOS



# ISL3298EMRTEP

## Revision History

The revision history provided is for informational purposes only and is believed to be accurate, but not warranted. Please go to web to make sure you have the latest Rev.

DATE	REVISION	CHANGE
7/28/11	FN7607.1	Changed in Features "Specifications per DSCC" to "Specifications per DLA" to match website.
1/27/11		In Figure 8 on page 7, corrected units in y axis from mA to $\mu$ A.
3/30/10	FN7607.0	Initial Release.

## Products

Intersil Corporation is a leader in the design and manufacture of high-performance analog semiconductors. The Company's products address some of the industry's fastest growing markets, such as, flat panel displays, cell phones, handheld products, and notebooks. Intersil's product families address power management and analog signal processing functions. Go to [www.intersil.com/products](http://www.intersil.com/products) for a complete list of Intersil product families.

\*For a complete listing of Applications, Related Documentation and Related Parts, please see the respective device information page on intersil.com: [ISL3298EMRTEP](http://www.intersil.com/ISL3298EMRTEP)

To report errors or suggestions for this datasheet, please go to [www.intersil.com/askourstaff](http://www.intersil.com/askourstaff)

FITs are available from our website at <http://rel.intersil.com/reports/search.php>

For additional products, see [www.intersil.com/product\\_tree](http://www.intersil.com/product_tree)

Intersil products are manufactured, assembled and tested utilizing ISO9000 quality systems as noted in the quality certifications found at [www.intersil.com/design/quality](http://www.intersil.com/design/quality)

*Intersil products are sold by description only. Intersil Corporation reserves the right to make changes in circuit design, software and/or specifications at any time without notice. Accordingly, the reader is cautioned to verify that data sheets are current before placing orders. Information furnished by Intersil is believed to be accurate and reliable. However, no responsibility is assumed by Intersil or its subsidiaries for its use; nor for any infringements of patents or other rights of third parties which may result from its use. No license is granted by implication or otherwise under any patent or patent rights of Intersil or its subsidiaries.*

For information regarding Intersil Corporation and its products, see [www.intersil.com](http://www.intersil.com)

## X-ON Electronics

Largest Supplier of Electrical and Electronic Components

*Click to view similar products for [RS-422/RS-485 Interface IC](#) category:*

*Click to view products by [Renesas](#) manufacturer:*

Other Similar products are found below :

[402824F](#) [702835FB](#) [MAX488ECPA](#) [MAX3491CSDT](#) [MAX3490AEGSA+](#) [MAX3483AEASA+](#) [MAX3491EESDT](#) [MAX3488AEGSA+](#)  
[MAX3083CSD](#) [MAX487CSA](#) [SP3071EEN-L](#) [SP3072EEN-L/TR](#) [SP3075EEN-L](#) [SP3075EEN-L/TR](#) [SP3077EEN-L](#) [SP3078EEN-L](#)  
[SP3078EEN-L/TR](#) [SP3082EEN-L](#) [SP3088EEN-L](#) [SP3483CN-L](#) [SP3483CN-L/TR](#) [SP3483EN-L](#) [SP3485CN-L](#) [SP3485CN-L/TR](#) [SP3485EN-](#)  
[L](#) [SP3485EN-L/TR](#) [SP3490EN-L](#) [SP3494EN-L](#) [SP481EEN-L/TR](#) [SP483EN-L/TR](#) [SP490EEN-L/TR](#) [SP491EN-L/TR](#) [XR3078XID-F](#)  
[SP3082EEN-L/TR](#) [SP330EEY-L/TR](#) [MAX14783EATA+T](#) [MAX3098EBCEE+T](#) [MAX3045BESE+T](#) [MAX22501EATA+T](#)  
[MAX22502EATC+T](#) [MAX3042BCSE+T](#) [SP3077EEN-L/TR](#) [MAX487ESA+TCBX](#) [MAX1483CUA+T](#) [MAX487CUA+T](#) [CA-IS3082W](#) [CA-](#)  
[IS3088W](#) [SP3074EEN-L/TR](#) [SP3483EN-L/TR](#) [NSI83085](#)